

CMOS linear image sensor

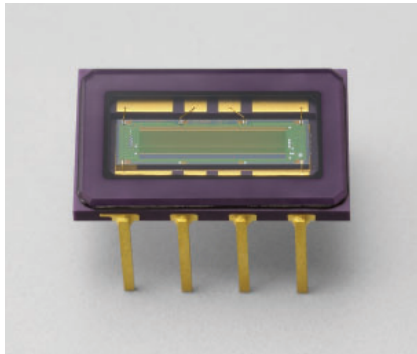

S9227-03

High-speed readout, simultaneous integration

The S9227-03 is a small CMOS linear image sensor designed for image input applications. Signal charge is integrated on all pixels simultaneously and then read out at high speeds of 5 MHz.

Features

- Pixel pitch: 12.5 μm
Pixel height: 250 μm
- 512 pixels
- 5 V single power supply operation
- Video data rate: 5 MHz max.
- Simultaneous charge integration
- Shutter function
- High sensitivity, low dark current, low noise
- Built-in timing generator allows operation with only start and clock pulse inputs.
- Spectral response range: 400 to 1000 nm
- 8-pin DIP (16-pin surface mount type also available)

Applications

- Position detection
- Image reading

Absolute maximum ratings

Parameter	Symbol	Value	Unit
Supply voltage	Vdd	-0.3 to +6	V
Clock pulse voltage	V(clk)	-0.3 to +6	V
Start pulse voltage	V(st)	-0.3 to +6	V
Operating temperature*1	Topr	-5 to +60	°C
Storage temperature*1	Tstg	-10 to +70	°C

*1: No condensation

Mechanical specifications

Parameter	Specification	Unit
Number of pixels	512	-
Pixel pitch	12.5	μm
Pixel height	250	μm
Active area length	6.4	mm
Window material	TEMPAX	-
Package	Ceramic	-

Recommended terminal voltage

Parameter	Symbol	Min.	Typ.	Max.	Unit
Supply voltage	Vdd	4.75	5	5.25	V
Clock pulse voltage	High level	Vdd - 0.25	Vdd	Vdd + 0.25	V
	Low level	-	0	-	V
Start pulse voltage	High level	Vdd - 0.25	Vdd	Vdd + 0.25	V
	Low level	-	0	-	V

Electrical characteristics [Ta=25 °C, Vdd=5 V, V(clk)=V(st)=5 V]

Parameter	Symbol	Min.	Typ.	Max.	Unit
Clock pulse frequency	f(clk)	50 k	-	5 M	Hz
Video data rate	VR	-	f(clk)	-	Hz
Power consumption	P	100	130	160	mW
Conversion efficiency	CE	-	1.6	-	μV/e ⁻
Output impedance*2	Zo	-	50	200	Ω

Electrical and optical characteristics [Ta=25 °C, Vdd=5 V, V(clk)=V(st)=5 V]

Parameter	Symbol	Min.	Typ.	Max.	Unit
Spectral response range	λ	400 to 1000			nm
Peak sensitivity wavelength	λp	-	700	-	nm
Dark current	Id	-	10	100	fA
Saturation charge	Qsat	320	420	-	fC
Dark output voltage*3	Vd	-	1	10	mV
Saturation output voltage*4	Vsat	4	4.3	-	V
Readout noise	Nr	-	1	2	mV rms
Offset output voltage	Vo	-	0.6	0.9	V
Photo response non-uniformity*5 *6	PRNU	-5	-	+5	%

*2: An increased current consumption at the video output terminal rises the sensor chip temperature causing an increased dark current. Connect a buffer amplifier for impedance conversion to the video output terminal so that the current flow is minimized. Use a JFET or CMOS input, high-impedance input op amp as the buffer amplifier.

*3: Integration time Ts=10 ms

*4: Voltage difference with respect to Vo, Ts=10 ms

*5: Uniformity is measured using 510 pixels excluding the pixels at both ends under the condition that the device is uniformly illuminated by light which is 50% of the saturation level, and is defined as follows:

$$PRNU = \frac{\Delta X}{X} \times 100 (\%)$$

X: the average output of all pixels, ΔX: difference between X and maximum or minimum output

*6: Measured with a tungsten lamp of 2856 K

Spectral response (typical example)

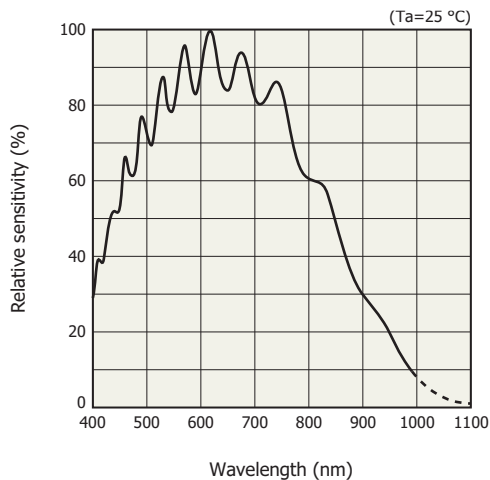

KMPD80230EC

Resolution

CTF: contrast transfer function

$$CTF = \frac{V_{WO} - V_{BO}}{V_W - V_B}$$

- V_{WO} : output white level
- V_{BO} : output black level
- V_W : output white level (when input pattern pulse width is wide)
- V_B : output black level (when input pattern pulse width is wide)

Contrast transfer function vs. spatial frequency (typical example)

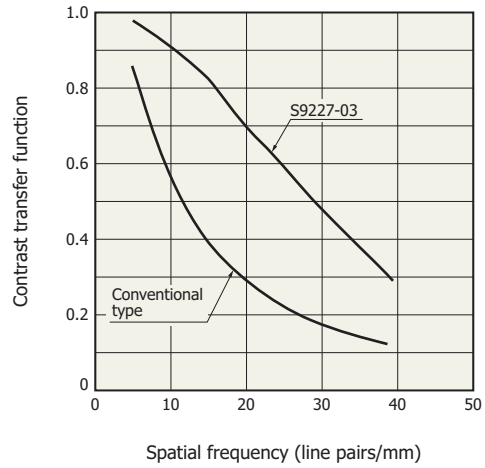

KMPDB0321EA

Dark output voltage vs. temperature (typical example)

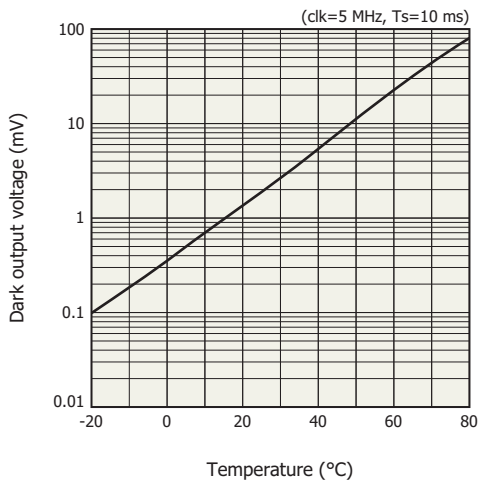

KMPDB0322EA

Current consumption vs. temperature (typical example)

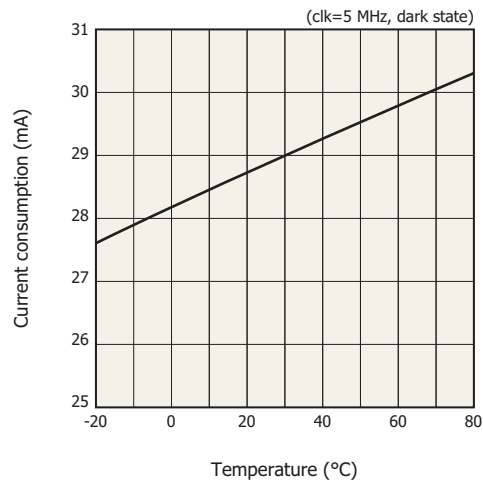

KMPDB0323EA

Output waveform of one element

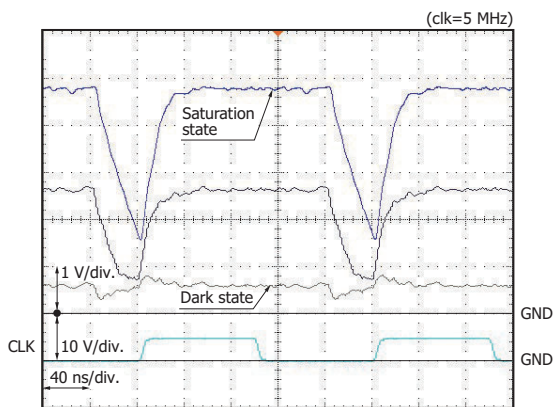

Timing chart

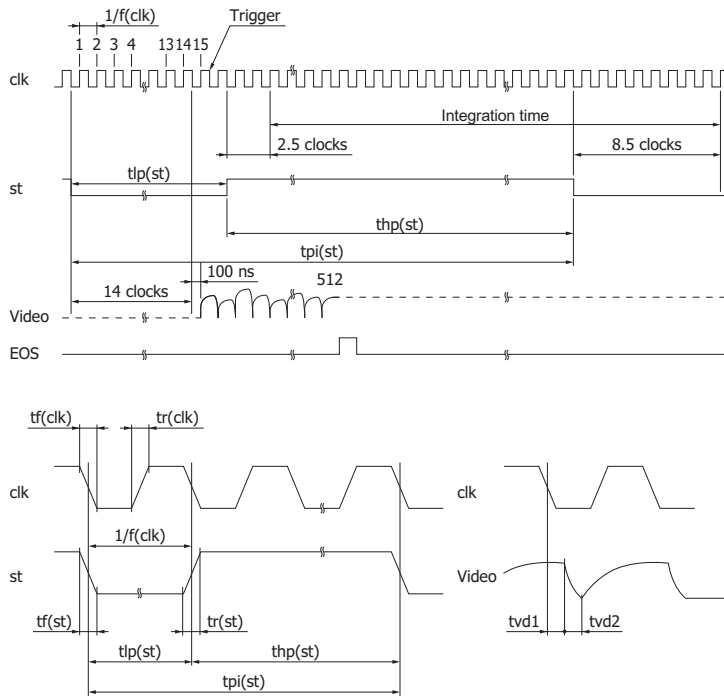

KMPDC0166EC

Parameter	Symbol	Min.	Typ.	Max.	Unit
Start pulse interval	$\text{tpi}(\text{st})$	$530/f(\text{clk})$	-	1100 m	s
Start pulse high period	$\text{thp}(\text{st})$	$8/f(\text{clk})$	-	1000 m	s
Start pulse low period	$\text{tlp}(\text{st})$	$15/f(\text{clk})$	-	100 m	s
Start pulse rise and fall times	$\text{tr}(\text{st}), \text{tf}(\text{st})$	0	20	30	ns
Clock pulse duty	-	45	50	55	%
Clock pulse rise and fall times	$\text{tr}(\text{clk}), \text{tf}(\text{clk})$	0	20	30	ns
Video delay time 1	tvd1	32	40	48	ns
Video delay time 2	tvd2	40	50	60	ns

Note: The internal timing circuit starts operating at the rise of clk pulse immediately after st pulse sets to low.

The integration time equals the high period of st pulse plus 6 clk cycles.

- The output from 1st channel appears 14 clocks plus 100 ns after the falling edge of st pulse.
- The EOS pulse is output 39 ns after the falling edge of clk pulse.
- The output voltage after reading the last pixel (512 ch) is indefinite.

Start pulse setting example (for setting the start pulse period to a minimum and the integration time to a maximum)

Start pulse high period= $515/f(\text{clk})$, Start pulse low period= $15/f(\text{clk})$

Block diagram

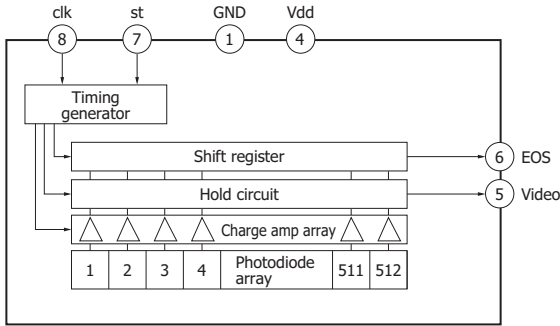

KMPDC0167EA

Pin connections

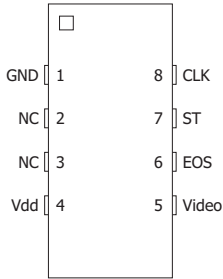

KMPDC0264EB

Pin no.	Symbol	Name of pin	Input/output
1	GND	Ground	Input
2	NC		Open
3	NC		Open
4	Vdd	Supply voltage	Input
5	Video	Video output	Output
6	EOS	End of scan	Output
7	st	Start pulse	Input
8	clk	Clock pulse	Input

Dimensional outline (unit: mm)

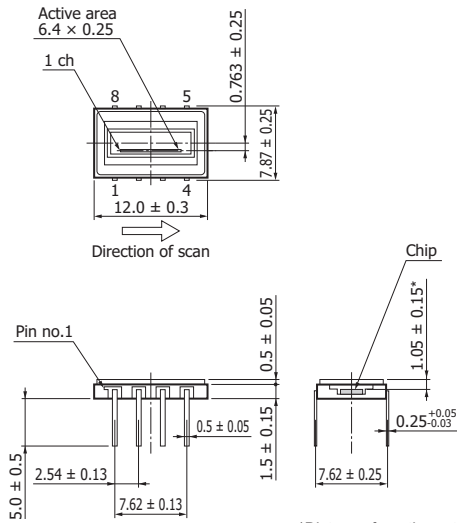

*Distance from the outer of the window to the chip surface

KMPDA0173EB

▣ Precautions during use

(1) Electrostatic countermeasures

This device has a built-in protection circuit against static electrical charges. However, to prevent destroying the device with electrostatic charges, take countermeasures such as grounding yourself, the workbench and tools to prevent static discharges. Also protect this device from surge voltages which might be caused by peripheral equipment.

(2) Light input window

If dust or dirt gets on the light input window, it will show up as black blemishes on the image. When cleaning, avoid rubbing the window surface with dry cloth or dry cotton swab, since doing so may generate static electricity. Use soft cloth, paper or a cotton swab moistened with alcohol to wipe dust and dirt off the window surface. Then blow compressed air onto the window surface so that no spot or stain remains.

(3) Soldering

To prevent damaging the device during soldering, take precautions to prevent excessive soldering temperatures and times. Soldering should be performed within 5 seconds at a soldering temperature below 260 °C.

(4) Operating and storage environments

Always observe the rated temperature range when handling the device. Operating or storing the device at an excessively high temperature and humidity may cause variations in performance characteristics and must be avoided.

(5) UV exposure

This product is not designed to prevent deterioration of characteristics caused by UV exposure, so do not expose it to UV light.

Information furnished by HAMAMATSU is believed to be reliable. However, no responsibility is assumed for possible inaccuracies or omissions.

Specifications are subject to change without notice. No patent rights are granted to any of the circuits described herein.

Type numbers of products listed in the specification sheets or supplied as samples may have a suffix "(X)" which means tentative specifications or a suffix "(Z)" which means developmental specifications. ©2009 Hamamatsu Photonics K.K.

HAMAMATSU

www.hamamatsu.com

HAMAMATSU PHOTONICS K.K., Solid State Division

1126-1 Ichino-cho, Higashi-ku, Hamamatsu City, 435-8558 Japan, Telephone: (81) 53-434-3311, Fax: (81) 53-434-5184

U.S.A.: Hamamatsu Corporation: 360 Foothill Road, P.O.Box 6910, Bridgewater, N.J. 08807-0910, U.S.A., Telephone: (1) 908-231-0960, Fax: (1) 908-231-1218

Germany: Hamamatsu Photonics Deutschland GmbH: Arzbergerstr. 10, D-82211 Herrsching am Ammersee, Germany, Telephone: (49) 8152-375-0, Fax: (49) 8152-265-8

France: Hamamatsu Photonics France S.A.R.L.: 19, Rue du Saule Trapu, Parc du Moulin de Massy, 91882 Massy Cedex, France, Telephone: 33-(1) 69 53 71 00, Fax: 33-(1) 69 53 71 10

United Kingdom: Hamamatsu Photonics UK Limited: 2 Howard Court, 10 Tewin Road, Welwyn Garden City, Hertfordshire AL7 1BW, United Kingdom, Telephone: (44) 1707-294888, Fax: (44) 1707-325777

North Europe: Hamamatsu Photonics Norden AB: Smidesvägen 12, SE-171 41 Solna, Sweden, Telephone: (46) 8-509-031-00, Fax: (46) 8-509-031-01

Italy: Hamamatsu Photonics Italia S.R.L.: Strada della Moia, 1/E, 20020 Arese, (Milano), Italy, Telephone: (39) 02-935-81-733, Fax: (39) 02-935-81-741