

S9703-10/-11

**High sensitivity, high-speed response**

The S9703 series photo IC uses a high-speed PIN photodiode designed for laser beam synchronous detection. When compared to the S9703 and S9703-01 previously marketed, the S9703-10 and S9703-11 have reduced their reflection effects in the package. Two types of current amplifiers are available with a gain of 6 times (S9703-11) and 20 times (S9703-10) that can be selected according to laser power to be used. Tape-and-reel shipment is available (S9703-30 and S9703-31). Hamamatsu also provides the S9684 series photo ICs that use a dual-element Si PIN photodiode.

**Features**

- ➔ **High sensitivity**  
Current amplifier gain: 20 times (S9703-10)  
6 times (S9703-11)
- ➔ **Digital output**
- ➔ **Small package**
- ➔ **Suitable for lead-free solder reflow**
- ➔ **Photosensitive area: 2.84 × 0.5 mm**

**Applications**

- ➔ **Print start timing detection for laser printers, digital copiers, fax machines, etc.**

**Absolute maximum ratings (Ta=25 °C, unless otherwise noted)**

Parameter	Symbol	Value	Unit
Supply voltage	Vcc	-0.5 to +7	V
Power dissipation*1	P	300	mW
Output voltage*2	Vo	-0.5 to +7	V
Output current	Io	5	mA
Ro terminal current	IRO	3	mA
Operating temperature	Topr	-25 to +80	°C
Storage temperature	Tstg	-40 to +85	°C

Note: Exceeding the absolute maximum ratings even momentarily may cause a drop in product quality. Always be sure to use the product within the absolute maximum ratings.

\*1: Power dissipation decreases at a rate of 4 mW/°C above Ta=25 °C.

\*2: Vcc=+0.5 V or less

**Electrical and optical characteristics (Ta=25 °C, λ=780 nm, Vcc=5 V, Ro=5.1 kΩ, unless otherwise noted)**

Parameter	Symbol	Condition	Min.	Typ.	Max.	Unit
Current consumption	I <sub>cc</sub>	No input	-	0.9	1.5	mA
High level output voltage	V <sub>OH</sub>	I <sub>OH</sub> =4 mA	4.6	-	-	V
Low level output voltage	V <sub>OL</sub>	I <sub>OL</sub> =4 mA* <sup>3</sup>	-	-	0.3	V
Threshold input power	S9703-10	P <sub>TH</sub>	17	22	27	μW
	S9703-11		60	75	90	
H→L propagation delay time	S9703-10	t <sub>PHL</sub>	-	100	200	ns
	S9703-11		-	75	150	
L→H propagation delay time	S9703-10	t <sub>PLH</sub>	-	200	250	
	S9703-11		-	150	200	
Rise time	t <sub>r</sub>	P <sub>I</sub> =66 μW (S9703-10) P <sub>I</sub> =225 μW (S9703-11) Duty ratio 1:1 C <sub>L</sub> =15 pF* <sup>4</sup>	-	4	7	ns
Fall time	t <sub>f</sub>		-	4	7	ns
Maximum input power	P <sub>I max</sub>		-	-	P <sub>TH</sub> × 8	μW

\*3: Input power [P<sub>I</sub>]=66 μW (S9703-10), P<sub>I</sub>=225 μW (S9703-11)

\*4: Measured with a pulse-driven laser diode. Rise time and fall time of input light-pulse are 1 ns or less.

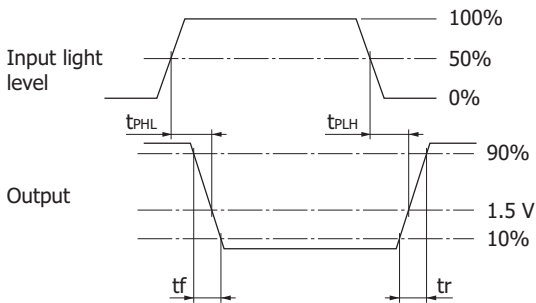

KPIC0112EA

**Block diagram**

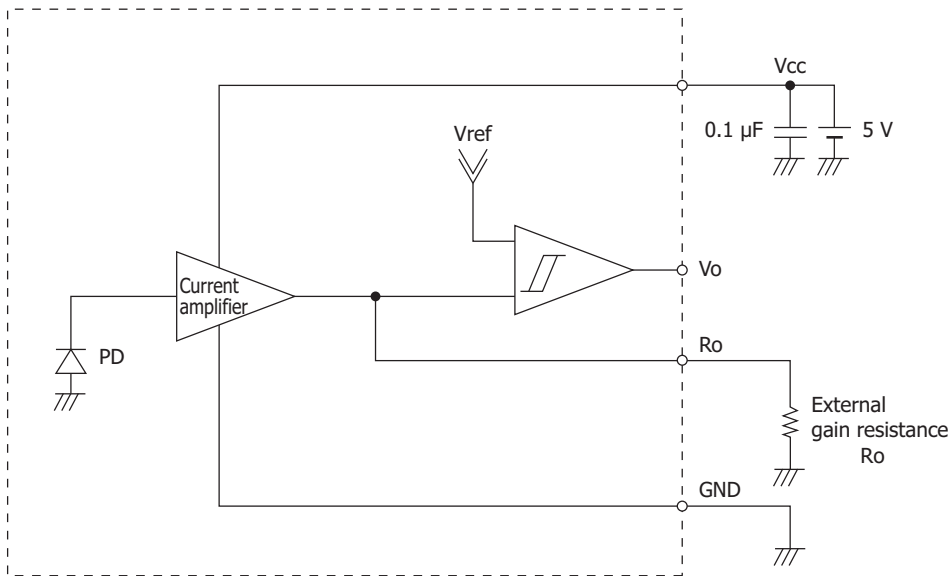

KPIC0113EA

**Function**

The S9703-10/-11 photo IC integrates a photodiode chip and an IC chip into the same package. The photodiode chip is internally connected to the IC chip as shown in the block diagram. The S9703-10/-11 should be used with terminal Ro connected to an external gain resistance Ro.

A photocurrent is generated when a laser beam enters the photodiode. This photocurrent is fed to the input terminal of the IC and, after being amplified by the current amplifier, flows to the external gain resistance. At this time, voltages VRO at terminal Ro is given by the following expression.

$$V_{RO} = A \times S \times P_I \times R_o \text{ [V]} \dots\dots (1)$$

A: Current amplifier gain (S9703-10: 20 times, S9703-11: 6 times)

S: Photodiode sensitivity [A/W] (approx. 0.44 A/W at 780 nm)

PI: Input power [W]

Ro: External gain resistance [ $\Omega$ ]; usable range 2 k $\Omega$  to 10 k $\Omega$

VRO is input to the internal comparator and compared with the internal reference voltage Vref (approx. 1 V) so the output Vo is "High" when VRO < Vref or "Low" when VRO > Vref.

In equation (1), set the Ro value so that VRO will be 2 to 3 V.

**Dimensional outline (unit: mm)**

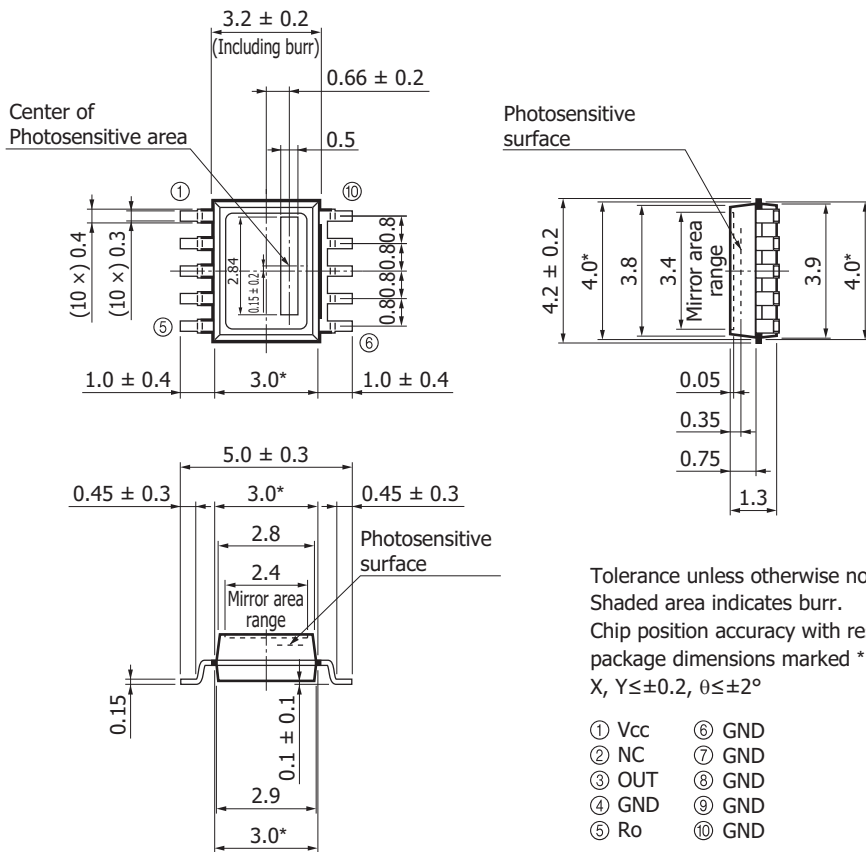

Tolerance unless otherwise noted: ±0.1, ±2°  
 Shaded area indicates burr.  
 Chip position accuracy with respect to the package dimensions marked \*  
 X, Y ≤ ±0.2, θ ≤ ±2°

KPICA0071EA

### Measured example of temperature profile with our hot-air reflow oven for product testing

These products support lead-free soldering. After unpacking, store them in an environment at a temperature of 30 °C or less and a humidity of 60% or less, and perform soldering within 24 hours.

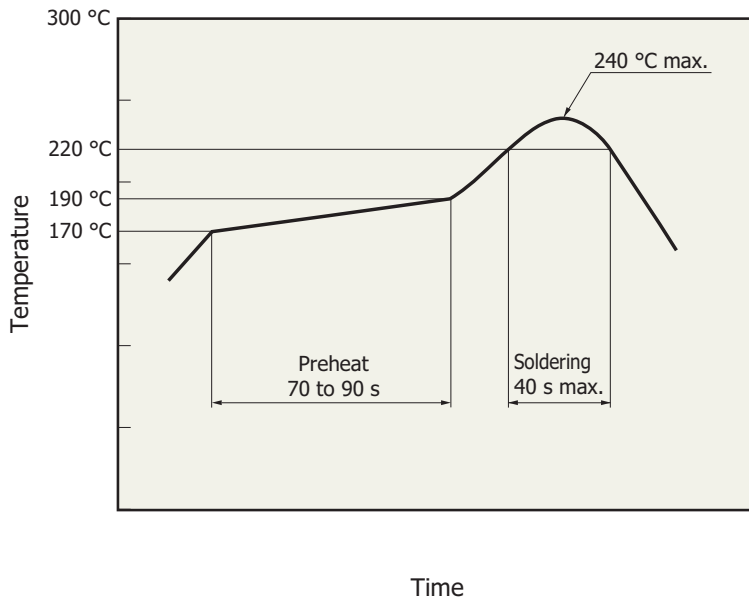

KPICB0171EA

Information described in this material is current as of March, 2013.

Product specifications are subject to change without prior notice due to improvements or other reasons. This document has been carefully prepared and the information contained is believed to be accurate. In rare cases, however, there may be inaccuracies such as text errors. Before using these products, always contact us for the delivery specification sheet to check the latest specifications.

The product warranty is valid for one year after delivery and is limited to product repair or replacement for defects discovered and reported to us within that one year period. However, even if within the warranty period we accept absolutely no liability for any loss caused by natural disasters or improper product use.

Copying or reprinting the contents described in this material in whole or in part is prohibited without our prior permission.

# HAMAMATSU

www.hamamatsu.com

HAMAMATSU PHOTONICS K.K., Solid State Division

1126-1 Ichino-cho, Higashi-ku, Hamamatsu City, 435-8558 Japan, Telephone: (81) 53-434-3311, Fax: (81) 53-434-5184

U.S.A.: Hamamatsu Corporation: 360 Foothill Road, P.O.Box 6910, Bridgewater, N.J. 08807-0910, U.S.A., Telephone: (1) 908-231-0960, Fax: (1) 908-231-1218

Germany: Hamamatsu Photonics Deutschland GmbH: Arzbergerstr. 10, D-82211 Herrsching am Ammersee, Germany, Telephone: (49) 8152-375-0, Fax: (49) 8152-265-8

France: Hamamatsu Photonics France S.A.R.L.: 19, Rue du Saule Trapu, Parc du Moulin de Massy, 91882 Massy Cedex, France, Telephone: 33-(1) 69 53 71 00, Fax: 33-(1) 69 53 71 10

United Kingdom: Hamamatsu Photonics UK Limited: 2 Howard Court, 10 Tewin Road, Welwyn Garden City, Hertfordshire AL7 1BW, United Kingdom, Telephone: (44) 1707-294888, Fax: (44) 1707-325777

North Europe: Hamamatsu Photonics Norden AB: Thorshamnsgatan 35 16440 Kista, Sweden, Telephone: (46) 8-509-031-00, Fax: (46) 8-509-031-01

Italy: Hamamatsu Photonics Italia S.R.L.: Strada della Moia, 1 int. 6, 20020 Arese, (Milano), Italy, Telephone: (39) 02-935-81-733, Fax: (39) 02-935-81-741

China: Hamamatsu Photonics (China) Co., Ltd.: 1201 Tower B, Jiaming Center, No.27 Dongsanhuan Beilu, Chaoyang District, Beijing 100020, China, Telephone: (86) 10-6586-6006, Fax: (86) 10-6586-2866