

Polyphase Energy Metering IC with Pulse Outputs and Anti-Tamper Features

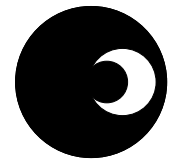

SA4301A

ICDC - a division of SAMES

FEATURES

- Meets the IEC62053, CBIP-88 and IS137799-1999 specification requirements for Class 1 AC static watt-hour meters for active energy
- Motor drive outputs (MOP, MON) provide average active power information and can drive an electro-mechanical counter or an impulse counter directly
- LED pulse output for calibration purposes supplies average active power information
- Configurable for different meter ratings
- Per phase energy direction indication
- Per phase missing phase indication
- Phase sequence error indication
- Precision on-chip oscillator (70ppm/°C drift)
- Precision on-chip voltage reference (10ppm/°C drift)
- On-chip anti-creep function (0.005% of E_{MAX})
- Low power consumption (<40mW typical)
- Measures AC inputs only

DESCRIPTION

The SAMES SA4301A is an accurate polyphase power/energy metering integrated circuit providing a single chip solution for three phase energy meters. Very few external components are required and the chip includes a direct drive capability for electro-mechanical counters. The SA4301A does not require an external crystal or voltage reference. A precision oscillator and a precision voltage reference to supply the circuitry with a stable frequency and stable reference currents are integrated on the chip.

The SA4301A metering integrated circuit generates a pulse output, the frequency of which is proportional to the active power consumption.

Programmable inputs allow the meter manufacturer to configure the SA4301A for different meter maximum

currents (I_{MAX}) and nominal voltages (V_{NOM}) without having to change the stepper motor counter or impulse counter gear ratio. The LED pulse output follows the average active power consumption measured and is intended for meter calibration purposes. In fast calibration mode this output provides a high frequency pulse rate following the average active power consumption and can be used for fast calibration or to interface with a micro-controller.

The SA4301A includes an anti-creep feature preventing any creep effects in the meter under no-load conditions.

The SA4301A integrated circuit is available in a 24-pin small outline (SOIC24) RoHS compliant package option.

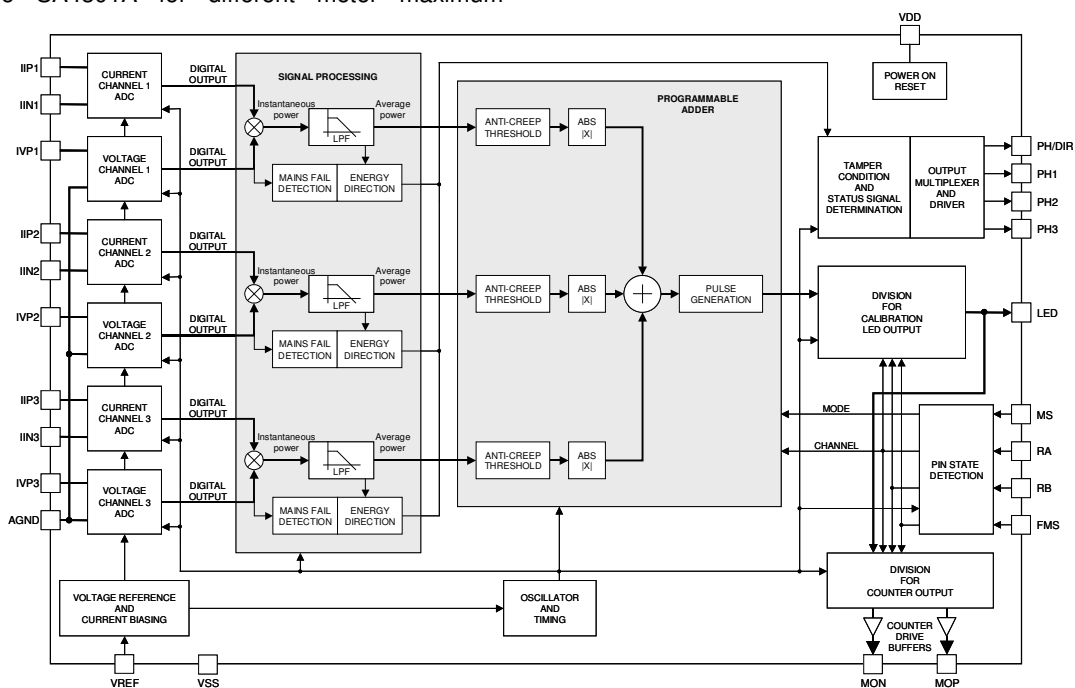

Figure 1: Block diagram

**ELECTRICAL CHARACTERISTICS**

($V_{DD} - V_{SS} = 5V \pm 10\%$, over the temperature range -40°C to $+85^{\circ}\text{C}$, unless otherwise specified. Refer to Figure 2 “Test circuit for electrical characteristics”.)

Parameter	Symbol	Min	Typ	Max	Unit	Condition
General						
Supply Voltage: Positive	V_{DD}	2.25	2.5	2.75	V	With respect to AGND
Supply Voltage: Negative	V_{SS}	-2.75	-2.5	-2.25	V	With respect to AGND
Supply Current: Positive	I_{DD}		7.5	10.5	mA	
Supply Current: Negative	I_{SS}		-7.5	-10.5	mA	
Analog Inputs						
Current Sensor Inputs (Differential)						
Input Current Range	$I_{RIP1}, I_{RIP2}, I_{RIP3}, I_{RIN1}, I_{RIN2}, I_{RIN3}$	-25		25	μA	Peak value
Offset Voltage	$VO_{IP1}, VO_{IP2}, VO_{IP3}, VO_{IN1}, VO_{IN2}, VO_{IN3}$	-4		4	mV	With $R = 4.7\text{k}\Omega$ connected to AGND
Voltage Sensor Inputs (Asymmetrical)						
Input Current Range	$I_{RIP1}, I_{RIP2}, I_{RIP3}$	-25		25	μA	Peak value
Offset Voltage	$VO_{IP1}, VO_{IP2}, VO_{IP3}$	-4		4	mV	With $R = 4.7\text{k}\Omega$ connected to AGND
Digital Inputs						
Pull-up/down Current on RA, RB, MS, FMS*	I_{PUD}	1.5		5.5	mA	
State Change Detection Time for Digital Inputs	T_{ST}			20	ms	
RA, RB, MS, FMS Input High Voltage	V_{IH}	$V_{DD}-1$			V	
Input Low Voltage	V_{IL}			$V_{SS}+1$	V	
Digital Outputs						
LED Output Frequency in FAST Mode	F_{MAX}	4.5	5	5.5	kHz	$16\mu\text{A}_{RMS}$ input current per channel
LED, PH1, PH2, PH3 Output High Voltage	V_{OH}	$V_{DD}-1$			V	$I_{SOURCE} = 5\text{mA}$
Output Low Voltage	V_{OL}			$V_{SS}+1$	V	$I_{SINK} = 5\text{mA}$
MOP, MON, PH/DIR Output High Voltage	V_{OH}		$V_{DD}-1$		V	$I_{SOURCE} = 10\text{mA}$
Output Low Voltage	V_{OL}		$V_{SS}+1$		V	$I_{SINK} = 10\text{mA}$

* This is the actual pull-up/down current during pin state scanning which is active for $70\mu\text{s}$ every 20ms. The average pull-up/down current is therefore between $5\mu\text{A}$ and $20\mu\text{A}$.

During manufacturing, testing and shipment we take great care to protect our products against potential external environmental damage such as Electrostatic Discharge (ESD). Although our products have ESD protection circuitry, permanent damage may occur on products subjected to high-energy electrostatic discharges accumulated on the human body and/or test equipment that can discharge without detection. Therefore, proper ESD precautions are recommended to avoid performance degradation or loss of functionality during product handling.

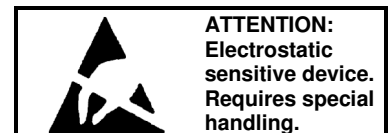



ELECTRICAL CHARACTERISTICS (continued)

($V_{DD} - V_{SS} = 5V \pm 10\%$, over the temperature range $-40^{\circ}C$ to $+85^{\circ}C$, unless otherwise specified. Refer to Figure 2 “Test circuit for electrical characteristics”.)

Parameter	Symbol	Min	Typ	Max	Unit	Condition
On-chip Voltage Reference						
Reference Voltage	V_R	1.15	1.20	1.25	V	
Reference Current	$-I_R$	24.4	25.5	26.6	μA	With $R = 47k\Omega$ connected to V_{SS}
Temperature Coefficient	TC_R		10	70	ppm/ $^{\circ}C$	
On-chip Oscillator						
Oscillator Frequency	f_{OSC}	3.15	3.57	4.00	MHz	
Temperature Coefficient	TC_{OSC}		70	200	ppm/ $^{\circ}C$	

ABSOLUTE MAXIMUM RATINGS*

Parameter	Symbol	Min	Max	Unit
Supply Voltage	$V_{DD} - V_{SS}$		6	V
Current on any Pin	I_{PIN}	-150	150	mA
Storage Temperature	T_{STG}	-60	+125	$^{\circ}C$
Specified Operating Temperature Range	T_O	-40	+85	$^{\circ}C$
Limit Range of Operating Temperature	T_{limit}	-40	+85	$^{\circ}C$

*Stresses above those listed under “Absolute Maximum Ratings” may cause permanent damage to the device. This is a stress rating only. Functional operation of the device at these or any other condition above those indicated in the operational sections of this specification, is not implied. Exposure to Absolute Maximum Ratings for extended periods may affect device reliability.

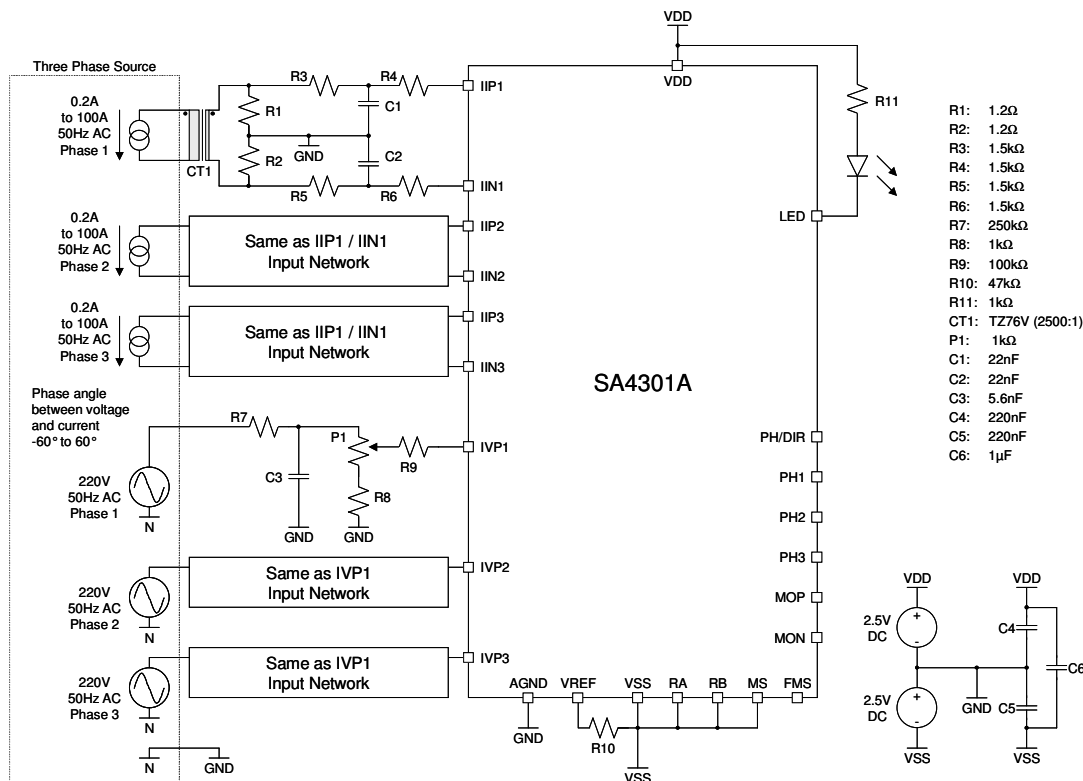

Figure 2: Test circuit for electrical characteristics

**PIN DESCRIPTION**

Designation	Pin No.	Description
AGND	20	Analog Ground. This is the reference pin for the current and voltage signal sensing networks. The supply voltage to this pin should be mid-way between V_{DD} and V_{SS} .
V_{DD}	6	Positive Supply Voltage. The voltage to this pin should be $+2.5V \pm 10\%$ with respect to AGND.
V_{SS}	18	Negative Supply Voltage. The voltage to this pin should be $-2.5V \pm 10\%$ with respect to AGND.
IVP1, IVP2, IVP3	21, 24, 3	Analog Inputs for Voltages. The maximum current into the voltage sense inputs IVP should be set at $16\mu A_{RMS}$. The voltage sense inputs saturate at an input current of $\pm 25\mu A$ peak.
IIP1, IIN1, IIP2, IIN2, IIP3, IIN3	22, 23, 1, 2, 4, 5	Analog Inputs for Currents. The maximum current into the current sense inputs IIP/IIN should be set at $16\mu A_{RMS}$. The current sense inputs saturate at an input current of $\pm 25\mu A$ peak.
VREF	19	This pin provides the connection for the reference current setting resistor. A $47k\Omega$ resistor connected to V_{SS} sets the optimum operating conditions.
RA, RB	7, 8	Rated Condition Select inputs. These four state input pins are used for selecting between the different rated condition configurations. The RA input is also used for channel selection when the device is placed in single phase calibration mode. Refer to the Rated Condition Select and Mode Select sections.
FMS	17	Fast Mode Select input. This three state input is used to select between STANDARD and FAST mode and provides an extended selection of meter constants. Refer to the Rated Condition Select and Fast Mode Select sections.
MS	9	Mode Select input. This four state input is used to select the mode of the programmable adder. Refer to the Mode Select section.
PH/DIR	13	Phase and Direction output. This output together with PH1, PH2 and PH3 indicates the energy flow direction and phase voltage information.
PH1, PH2, PH3	14, 15, 16	Multiplexed outputs used together with the PH/DIR output to indicate energy flow direction and phase voltage information.
LED	10	Calibration LED output. Refer to the Rated Condition Select section for the pulse rate output options.
MON, MOP	11, 12	Motor pulse outputs. These outputs can drive an electro-mechanical counter directly. Refer to the Rated Condition Select section for the pulse rate output options.

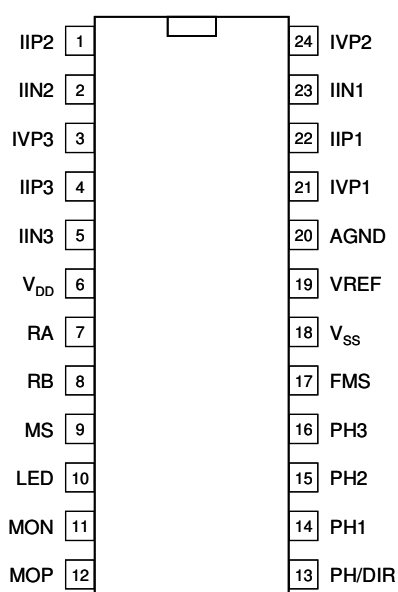

Figure 3: Pin connections

ORDERING INFORMATION

Part Number	Package
SA4301ASAR	SOIC24 (RoHS compliant)



TERMINOLOGY

Anti-Creep Threshold

The anti-creep threshold is defined as the minimum energy threshold below which no energy is registered and therefore no pulses are generated on the LED or motor drive outputs.

Positive Energy

Positive energy is defined when the phase difference between the input signals IIP and IVP is less than 90 degrees (-90..90 degrees).

Negative Energy

Negative energy is defined when the phase difference between the input signals IIP and IVP is greater than 90 degrees (90..270 degrees).

Percentage Error*

Percentage error is given by the following formula:

$$\%Error = \frac{\text{Energy registered by device} - \text{True Energy}}{\text{True Energy}} \times 100$$

NOTE: Since the true value cannot be determined, it is approximated by a value with a stated uncertainty that can be traced to standards agreed upon between manufacturer and user or to national standards.

Rated Operating Conditions*

Set of specified measuring ranges for performance characteristics and specified operating ranges for influence quantities, within which the variations or operating errors of a meter are specified and determined.

Specified Measuring Range*

Set of values of a measured quantity for which the error of a meter is intended to lie within specified limits.

Specified Operating Range*

A range of values of a single influence quantity, which forms a part of the rated operating conditions.

Limit Range of Operation*

Extreme conditions which an operating meter can withstand without damage and without degradation of its metrological characteristics when it is subsequently operated under its rated operating conditions.

Maximum Rated Mains Current (I_{MAX})

Maximum rated mains current is the specified maximum current flowing through the energy meter at rated operating conditions.

Constant*

Value expressing the relation between the active energy registered by the meter and the corresponding value of the test output. If this value is a number of pulses, the constant should be either pulses per kilowatt-hour (imp/kWh) or watt-hours per pulse (Wh/imp).

Nominal Mains Voltage (V_{NOM})

Nominal mains voltage (V_{NOM}) is the voltage specified for the energy meter at rated operating conditions.

Maximum Channel Energy (E_{MAX})

The maximum channel energy is defined as the energy registered on one channel of the SA4301A when $16\mu A_{RMS}$ input current with zero phase shift are applied to the voltage and current inputs. Both the voltage and current inputs saturate at an input current magnitude of $25\mu A$, or at $17.68\mu A_{RMS}$ when using sine waves. The maximum input current on each channel is therefore defined to be $16\mu A_{RMS}$, which leaves about 10% headroom to the saturation point.

Maximum Output Frequency (F_{MAX})

The maximum output frequency (F_{MAX}) is the output frequency in FAST mode when each of the three channels measures an amount of energy equal to E_{MAX} . The nominal output frequency is 5kHz under such conditions.

Repeatability of Error Test**

This test shall be carried out at 0.05lb and 1b at UPF load under reference test conditions. Twenty error samples shall be taken at time intervals of 30 minutes. Identical test conditions shall be maintained throughout the test. For an acceptance test six error tests may be carried out at time intervals of at least 5 minutes.

Total Sum

This represents the arithmetic sum of the active energy from each channel taking energy flow direction into account. Negative energy flow is effectively subtracted from the sum.

Absolute Sum

This represents the arithmetic sum of the active energy from each channel regardless of the direction of the energy flow. The absolute values of the active energy recorded on each individual channel are summed.

* IEC 62052-11, 2003. Electricity Metering Equipment (AC) – General Requirements, Test and Test Conditions – Part 11: Metering Equipment

** IS13779-1999 Indian Standard AC Static Watt-hour Meters Class 1 and 2 Specification Rev 1



PERFORMANCE GRAPHS

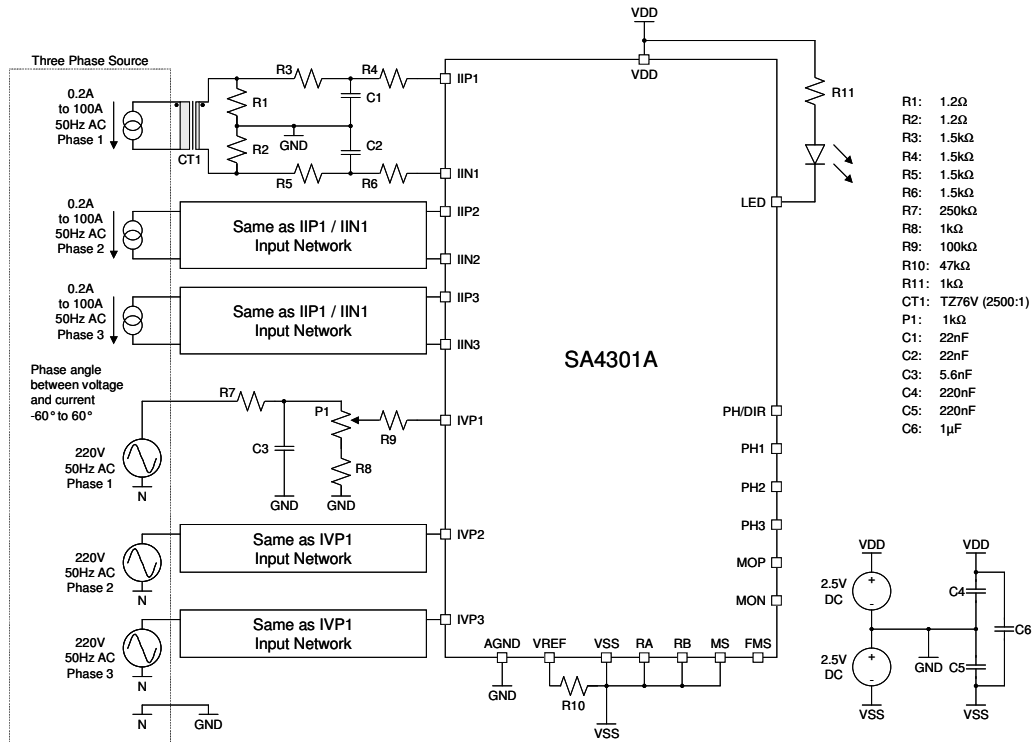
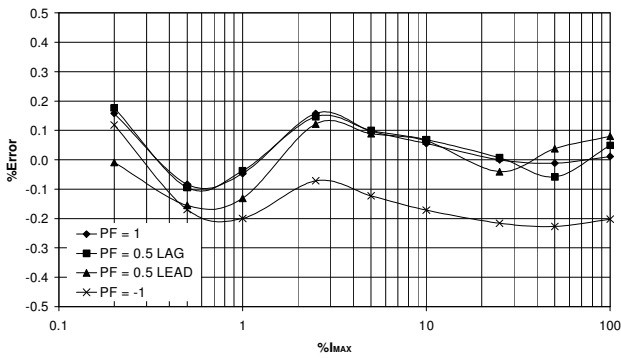
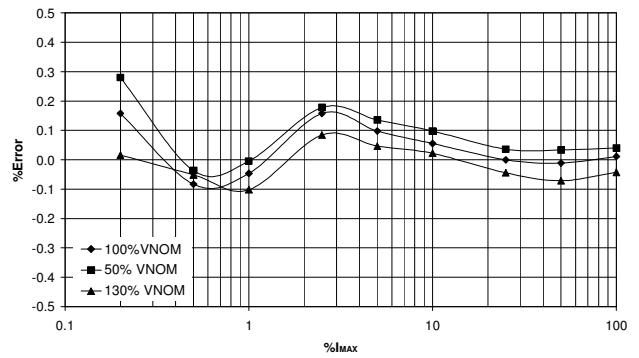

Figure 4: Test circuit for performance graphs



GRAPH 1 - Freq = 50Hz, V_{NOM} , Temp = 25 °C, $V_{DD}-V_{SS} = 5.0V$



GRAPH 2 - PF = 1, Freq = 50Hz, Temp = 25 °C, $V_{DD}-V_{SS} = 5.0V$

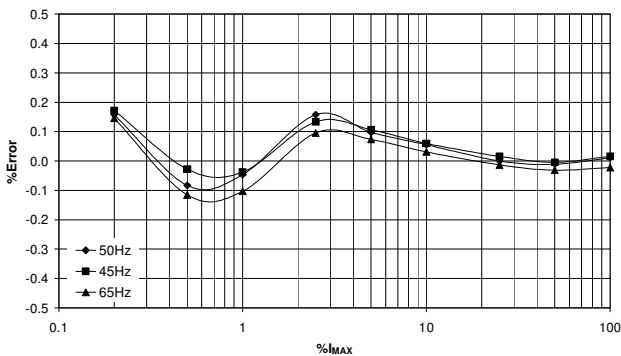

GRAPH 3 - PF = 1, V_{NOM} , Temp = 25 °C, $V_{DD}-V_{SS} = 5.0V$

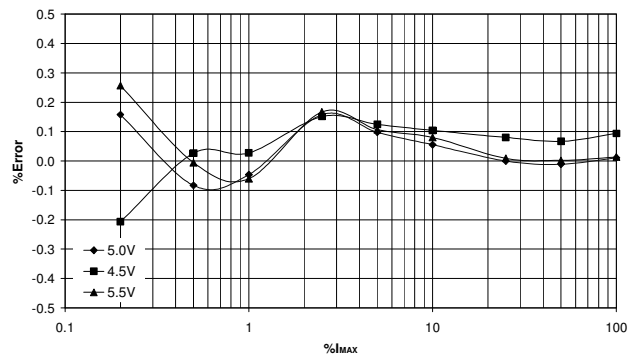

GRAPH 4 - PF = 1, Freq = 50Hz, V_{NOM} , Temp = 25 °C



FUNCTIONAL DESCRIPTION

Theory of Operation

The SA4301A includes all the required functions for three channel polyphase power and energy measurement. Three pairs of identical AD converters sample the three phase voltage and current input signals. The three pairs of digital signals, accurately representing the voltage and current inputs, are multiplied using digital multiplication. The output of each multiplier represents the instantaneous power on each channel, which is subsequently low pass filtered and integrated over time to remove the instantaneous components. The three channels are added together using the programmable adder, forming the total averaged instantaneous energy. This energy is accumulated over time to form the outputs of the device.

For given voltage and current signals the instantaneous power is calculated by:

$$p(t) = v(t) \times i(t)$$

$$p(t) = V_M \cos(\omega t + \theta) \times I_M \cos(\omega t + \psi)$$

Let $\phi = \theta - \psi$, and $V_{RMS} = \frac{V_M}{\sqrt{2}}$ and $I_{RMS} = \frac{I_M}{\sqrt{2}}$ then

$$p(t) = V_M \cos(\omega t + \theta) \times I_M \cos(\omega t + \theta - \phi)$$

$$p(t) = V_{RMS} I_{RMS} (\cos \phi - \cos(2(\omega t + \theta) - \phi))$$

where

$p(t)$ is the instantaneous power,

$v(t)$ is the instantaneous voltage signal,

$i(t)$ is the instantaneous current signal,

V_M is the amplitude of the voltage signal,

I_M is the amplitude of the current signal,

θ is the phase angle of the voltage signal and

ψ is the phase angle of the current signal.

The instantaneous power is low pass filtered to remove the double mains frequency component $\cos(2(\omega t + \theta) - \phi)$ and is then integrated over time to provide the average power information

$$P = \frac{1}{T} \int_0^T p(t) dt$$

$$P = V_{RMS} I_{RMS} \cos \phi$$

where

P is the average power and

$\cos \phi$ is the power factor.

Linearity

The SA4301A is a CMOS integrated circuit, which performs power/energy calculations across a dynamic range of 500:1 to an accuracy that exceeds the IEC62053 specification.

Analog Inputs

The input circuitry of the current and voltage sensor inputs is illustrated in Figure 5. These inputs are protected against electrostatic discharge through clamping diodes. The feedback loops from the outputs of the amplifiers A_I and A_V generate virtual short circuits between IIP and IIN as well as IVP and AGND. The current sense inputs (IIP and IIN) are identical and balanced. The AD converters convert the signals on the voltage and current sense inputs to a digital format for further processing. All internal offsets are eliminated through the use of various cancellation techniques.

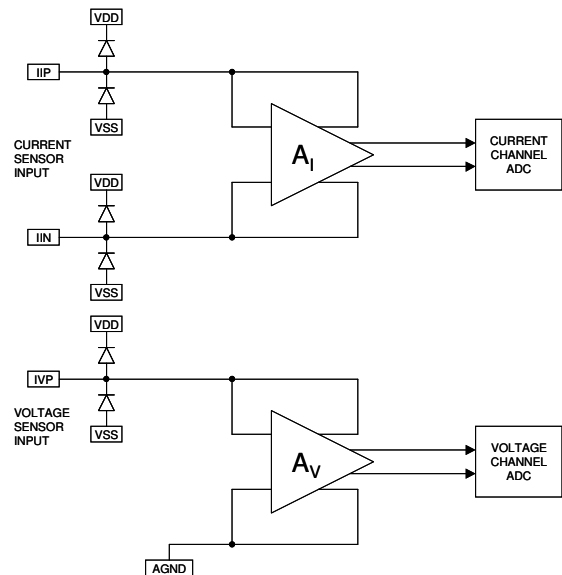

Figure 5: Analog input configuration

Digital Outputs

The calculations required for power and energy are performed and converted to pulses on the LED, MON and MOP outputs. The complimentary output pins MON and MOP are provided for driving a stepper motor counter directly. The output frequency on the LED output is, in both STANDARD and FAST mode, proportional to the average active power consumption measured. The FAST mode is intended for fast meter calibration and verification purposes or for interfacing the SA4301A to a micro-controller.

Anti-Creep Threshold

An integrated anti-creep function prevents any output pulses from a specific channel from appearing on the LED output and the MON/MOP motor drive outputs if the energy measured on that channel is less than 0.005% of E_{MAX} , where E_{MAX} is the energy registered on that channel when the input currents for voltage and current are $16\mu A_{RMS}$ with zero phase shift.



Reverse Energy Flow Indication

The SA4301A assesses the phase difference between any voltage channel signal and its corresponding current channel signal. If this phase difference is greater than 90 degrees then the reverse current LED indication will be displayed on the multiplexed LED array. This facility is designed to detect the wrongful connection of the meter. This operation is fully described in the Output Signals section.

Starting Current

The SA4301A generates pulses on the LED and MON/MOP outputs for an input power greater than 0.005% of E_{MAX} on any of the three channels. This is to comply with the IEC requirement where the meter is required to generate pulses for currents greater than 0.4%I_b.

Calibration and Repeatability

The SA4301A provides an output (LED) that is used for calibration of the meter. The meter is calibrated by comparing the energy reading of the meter under test with the energy reading of the reference meter. Each channel is calibrated independently. The reference meter should have a considerably higher pulse rate than the meter under test. The accuracy to which the meter has to be calibrated will dictate how much higher the reference meter pulse rate has to be. The SA4301A can be calibrated to specification with a minimum of two pulses on the LED output whilst in

STANDARD mode and utilizing an appropriate reference meter. This reading is independent of time and will be repeatable so as to consistently achieve the required accuracy for the full input current range that needs to be measured to IEC62053 accuracy. In Figure 6 the reference meter pulses are counted between two pulses of the meter under test. The meter under test is then adjusted so as to reflect the expected number of counted reference meter pulses. A worst-case scenario is for measurements obtained for only two pulses of the meter under test and N pulses from the reference meter. In this case the measurement resolution will be:

$$\text{Measurement Resolution (\%)} = \frac{1}{N} \times 100$$

The corresponding calibration and repeatability results can never be more accurate than this measurement resolution.

Power-On Reset

The SA4301A has a power-on reset circuitry that activates whenever the voltage between V_{DD} and V_{SS} is less than 3.6V ± 8%.

Power Consumption

The power consumption of the SA4301A integrated circuit is less than 60mW.

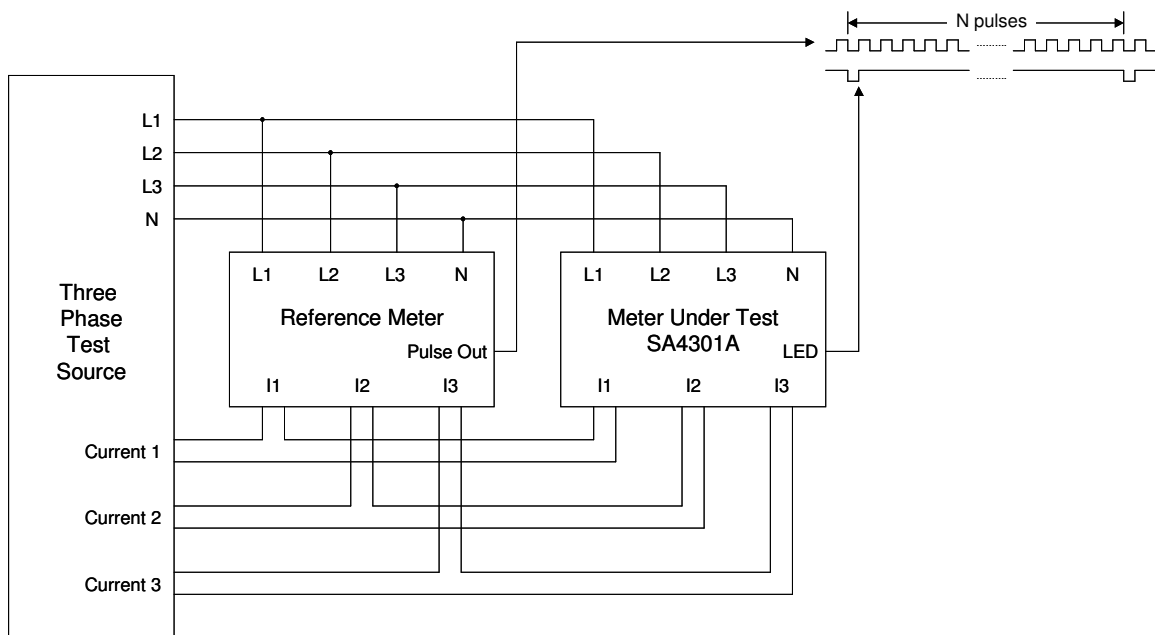

Figure 6: Calibration and repeatability setup



INPUT SIGNALS

Voltage Reference (VREF)

A bias resistor of 47kΩ sets optimum bias and reference conditions on chip. Calibration of the SA4301A should be done on the voltage inputs and not on the VREF input.

Current Sense Inputs (IIP1/IIN1, IIP2/IIN2, IIP3/IIN3)

Figure 7 shows the typical connections for the current sensor input for one channel. The circuit has to be repeated for the other two channels. At maximum rated mains current (I_{MAX}) the resistor values should be selected for input currents of $16\mu A_{RMS}$. The current sense inputs saturate at an input current of $\pm 17.6\mu A_{RMS}$ ($\pm 25\mu A_{PEAK}$), so this allows about 10% headroom until saturation occurs. The resistors RA and RB form the current transformers termination resistor. The reference level is connected in the centre of the termination resistor to achieve purely differential input currents. The voltage drop across the termination resistors at maximum rated mains current (I_{MAX}) should be in the order of $100mV_{RMS}$. The termination resistance should also be significantly smaller than the DC resistance of the current transformers secondary winding.

The resistors R1 to R4 define the current flowing into the device. For best performance the SA4301A requires anti-alias filters on the current sense inputs. These filters are realized by means of the capacitors C1 and C2. The typical cut-off frequency of these filters should be between 10kHz and 20kHz. The optimum input network is achieved by setting the input resistors equal, i.e. setting $R1 = R2 = R3 = R4 = R_C$. This sets the equivalent resistance associated with each capacitor to $R_C/2$.

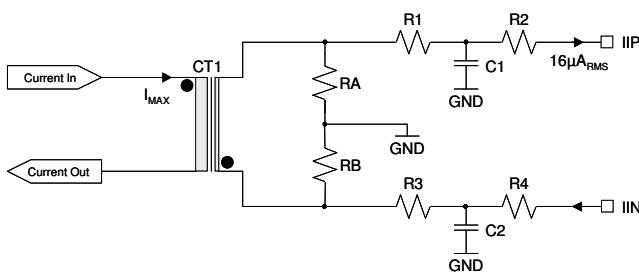

Figure 7: Current sense input configuration

Voltage Sense Inputs (IVP1, IVP2, IVP3)

Figure 8 shows the voltage sense input configuration for one channel. The circuit is identical for the other two channels. The voltage sense input saturates at an input current of $\pm 17.6\mu A_{RMS}$ ($\pm 25\mu A_{PEAK}$). The current into the voltage sense input should therefore be set between $11\mu A_{RMS}$ and $12\mu A_{RMS}$ at nominal mains voltage (V_{NOM}) to allow for a mains voltage variation of up to +30% and -50% without saturating the voltage sense input.

Typical V_{NOM} values and the corresponding IVP input currents are shown in the following table.

Table 1: IVP input current for typical values of V_{NOM}

V_{NOM} (V)	IVP Input Current (μA_{RMS})
110 / 220	11
115 / 230	11.5
120 / 240	12

For best performance the SA4301A also requires an anti-alias filter on the voltage sense inputs. Referring to Figure 8, the capacitor C1 is used to both implement the anti-alias filter as well as compensating for any phase shift caused by the current transformer. The resistor R4 defines the input current into the device. The optimum input network is achieved by setting R4 in the order of 100kΩ. If R4 is made too large the capacitor C1 will be very small and the accuracy of the phase compensation could be affected by stray capacitances. The potentiometer P1 is used for calibration purposes.

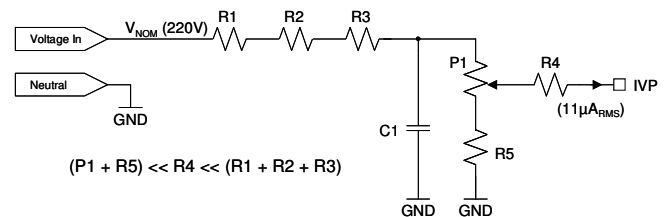

Figure 8: Voltage sense input configuration

Fast Mode Select (FMS)

The Fast Mode Select input (FMS) is used to select between STANDARD and FAST mode as well as to select between a multitude of meter constants and motor drive dividing ratios. Connecting this pin to V_{DD} or V_{SS} enables the STANDARD mode of operation while leaving this pin floating enables the FAST mode of operation. When STANDARD mode is enabled the LED output pulses at a low frequency. This low frequency allows a longer accumulation period and the output pulse rate is therefore proportional to the average power consumption measured.

The Rated Condition Select pins (RA, RB) together with the FMS pin are used to select different LED output frequencies which in turn determine the applications meter constant. Refer to Figure 9 for the LED output timing diagram. When the FAST mode is enabled the LED output generates pulses at a nominal frequency of 5kHz at I_{MAX} and V_{MAX} on each channel. In this mode the pulse frequency is proportional to the average power consumption measured. This mode is useful when interfacing to a micro-controller.



When FMS is floating the LED pin outputs fast mode pulses. The motor pulses occur as usual based on the last FMS before a floating condition was detected as well as the current states of RA and RB. If a floating condition on FMS is detected at device start-up the motor pulses are generated based on FMS set to V_{SS}.

Table 2: LED and motor division factors

FMS	RB	RA	DF_LED	DF_MO
0	0	0	146	128
0	0	1	292	64
0	0	Z	584	32
0	0	PH/DIR	1168	16
0	1	0	146	64
0	1	1	292	32
0	1	Z	584	16
0	1	PH/DIR	1168	8
0	Z	0	146	32
0	Z	1	292	16
0	Z	Z	584	8
0	Z	PH/DIR	1168	4
0	PH/DIR	0	146	16
0	PH/DIR	1	292	8
0	PH/DIR	Z	584	4
0	PH/DIR	PH/DIR	1168	2
1	0	0	976	32
1	0	1	1952	16
1	0	Z	234	32
1	0	PH/DIR	468	16
1	1	0	392	16
1	1	1	784	8
1	1	Z	234	16
1	1	PH/DIR	468	8
1	Z	0	392	8
1	Z	1	784	4
1	Z	Z	234	8
1	Z	PH/DIR	468	4
1	PH/DIR	0	196	8
1	PH/DIR	1	392	4
1	PH/DIR	Z	156	8
1	PH/DIR	PH/DIR	312	4

Note: Pin values defined as follows
 0 pin is connected to V_{SS}
 1 pin is connected to V_{DD}
 Z pin is left floating
 PH/DIR pin is connected to PH/DIR

Rated Condition Select (RA, RB)

The Rated Condition Select inputs (RA and RB) along with the Fast Mode Select input (FMS) are used for obtaining a multitude of meter constants and motor drive ratios. The different LED and motor division factors (DF_LED and DF_MO) that can be selected via RA, RB and FMS are shown in Table 2.

To calculate the LED output pulse constant in STANDARD mode and the motor drive pulse constant for any meter rating (I_{MAX} and V_{NOM}) the following formulae can be used:

$$\text{LED imp/kWh} = \frac{\text{IVP}}{16} \times \frac{5000}{\text{DL_LED}} \times \frac{1000 \times 3600}{3 \times V_{\text{NOM}} \times I_{\text{MAX}}} \quad (1)$$

where

I_{MAX} = maximum rated mains current,

V_{NOM} = nominal mains voltage,

IVP = the analog input current on the voltage sense inputs at V_{NOM} as specified in Table 1 and

DF_LED = the dividing factor for the LED output that is set by the combination of RA, RB and FMS as specified in Table 2.

Equation 1 is based on the assumption that the input currents into the IIP/IIN current sense inputs are set to 16µA_{RMS} at I_{MAX}.

$$\text{Motor imp/kWh} = \frac{\text{LED imp/kWh}}{\text{DF_MO}} \quad (2)$$

where

LED imp/kWh = the LED constant as calculated using Equation 1 and

DF_MO = the dividing factor for the motor output that is set by the combination of RA, RB and FMS as specified in Table 2.

Table 3 illustrates some of the possible LED and motor constants that are achievable for some common values of I_{MAX} using a V_{NOM} between 220V and 240V.



Table 3: LED and motor constants achievable for some common I_{MAX} currents for $V_{NOM} = 220V$ to $240V$

I_{MAX} (A)	Dividing Factors		LED Output (imp/kWh)	Motor Output (imp/kWh)
	DF_LED	DF_MO		
6	976	32	3200	100
6	1952	16	1600	100
10	146	128	12800	100
10	292	64	6400	100
10	584	32	3200	100
10	1168	16	1600	100
10	146	64	12800	200
10	292	32	6400	200
10	584	16	3200	200
10	1168	8	1600	200
10	146	32	12800	400
10	292	16	6400	400
10	584	8	3200	400
10	1168	4	1600	400
10	146	16	12800	800
10	292	8	6400	800
10	584	4	3200	800
10	1168	2	1600	800
20	146	64	6400	100
20	292	32	3200	100
20	584	16	1600	100
20	1168	8	800	100
20	146	32	6400	200
20	292	16	3200	200
20	584	8	1600	200
20	1168	4	800	200
20	146	16	6400	400
20	292	8	3200	400
20	584	4	1600	400
20	1168	2	800	400
25	234	32	3200	100
25	468	16	1600	100
25	234	16	3200	200
25	468	8	1600	200
25	234	8	3200	400
25	468	4	1600	400

I_{MAX} (A)	Dividing Factors		LED Output (imp/kWh)	Motor Output (imp/kWh)
	DF_LED	DF_MO		
30	392	16	1600	100
30	784	8	800	100
30	392	8	1600	200
30	784	4	800	200
30	196	8	3200	400
30	392	4	1600	400
40	146	32	3200	100
40	292	16	1600	100
40	584	8	800	100
40	1168	4	400	100
40	146	16	3200	200
40	292	8	1600	200
40	584	4	800	200
40	1168	2	400	200
50	234	16	1600	100
50	468	8	800	100
50	234	8	1600	200
50	468	4	800	200
60	392	8	800	100
60	784	4	400	100
60	196	8	1600	200
60	392	4	800	200
80	146	16	1600	100
80	292	8	800	100
80	584	4	400	100
80	1168	2	200	100
100	234	8	800	100
100	468	4	400	100
120	196	8	800	100
120	392	4	400	100
150	156	8	800	100
150	312	4	400	100



Mode Select (MS)

The Mode Select (MS) input is used to set different operation modes of the device as illustrated in Table 4. The MS input controls the programmable adder. This adder sums the individual channel energy values. The summing mode as well as the channel selection, when in calibration mode, can be controlled.

Table 4: Adder mode selection via the MS input

MS Input	Programmable Adder Mode
V _{SS}	Total Sum
V _{DD}	Absolute Sum
Floating	Single Phase Calibration
PH/DIR	Sum of Positive Energy

Total Sum: The total sum mode is the arithmetic sum of the three active energies, $E_{TOT} = E_{CH1} + E_{CH2} + E_{CH3}$. The direction of the energy flow is taken into account during all calculations. Therefore negative energy flow will effectively be subtracted from positive energy flow. Setting MS to V_{SS} selects the total sum mode.

Absolute Sum: The absolute sum is the arithmetic sum of the three active energies that is obtained by disregarding the direction of energy flow, $E_{TOT} = |E_{CH1}| + |E_{CH2}| + |E_{CH3}|$. The absolute value of each channels energy is taken before summing. Setting MS to V_{DD} sets absolute sum mode.

Sum of Positive (Import) Energy: The sum of positive energy is the arithmetic sum of the positive active energies registered on the three channels only. If a specific channel detects negative energy, this energy is not included in the sum. Connecting the MS pin to PH/DIR sets the programmable adder to the sum of positive energy summing mode.

Single Phase Calibration: The SA4301A can also be set to a single phase calibration mode by leaving the MS pin floating. In this mode it is possible to enable each channel individually. This is intended for meter calibration. The programmable adder uses only the energy from the selected channel, the remaining two channels are effectively internally masked and do not require external disconnection. The value on RA determines the channel that requires calibration as listed in Table 5. The initial value of RA as detected before the single phase calibration mode is enabled is internally saved so that the meter constant is not affected by changing RA during single phase calibration mode. If the single phase calibration mode is detected at device start-up this internal value for RA defaults to logic 0 (RA = V_{SS}).

Table 5: Channel selection in single phase calibration mode via the RA input

RA Input	Selected Channel
V _{SS}	1
V _{DD}	2
Floating	3
PH/DIR	None

OUTPUT SIGNALS

LED Output (LED)

The LED output pin provides a pulse output with a frequency proportional to the average active energy consumption measured when in STANDARD mode or FAST mode. A low pass filter is applied to the instantaneous energy output directly after multiplication. This filtering allows all instantaneous components to be removed resulting in a constant output frequency at constant energy input, even over a short period of time. The delay of this filter is about 200ms.

The LED output is primarily used for calibration purposes. The Rated Condition Select inputs (RA, RB) and the Fast Mode Select input (FMS) allow different nominal output frequencies to be selected. The FMS input also allows selection between STANDARD mode and FAST mode. The LED output is active low. Figure 9 shows the LED output waveform.

In FAST mode the LED pulse output is set to a nominal frequency of 5kHz at an input current of 16μA_{RMS} on each of the three current and voltage channels.

The nominal output frequency of the LED pin is given by

$$f_{LED_FAST} = 5000 \times \frac{|IV_1 \times I_{I1} \times \cos \phi_1 + IV_2 \times I_{I2} \times \cos \phi_2 + IV_3 \times I_{I3} \times \cos \phi_3|}{3 \times 16^2} \quad (3)$$

in FAST mode where

IV_X and I_{IX} = the analog input currents in μA_{RMS} on the voltage and current sense inputs on channel X and $\cos \phi_X$ = the phase angle between the current and voltage signals on channel X.

Equation 3 is valid for total sum mode. If any other programmable adder mode is selected then the above equation has to be modified. In absolute sum mode the absolute value of each $\cos \phi_X$ has to be taken, in sum of positive energy mode any $\cos \phi_X$ that is negative has to be made zero and in single phase calibration mode the $\cos \phi_X$ of the non-selected channels has to be made zero.



In STANDARD mode the nominal LED output frequency is

$$f_{LED_STD} = \frac{f_{LED_FAST}}{DF_LED} \quad (4)$$

where

f_{LED_FAST} = the FAST mode output frequency as per Equation 3 and

DF_LED = the LED divider selected by RA, RB and FMS according to Table 2.

The timing values given below are based on the nominal frequency value of the internal oscillator.

t_L = $1/f_{LED_FAST}$ in FAST mode (f_{LED_FAST} as per Equation 3)
 = $1/f_{LED_STD}$ in STANDARD mode (f_{LED_STD} as per Equation 4)

t_{LP} = 91.5ms when $t_L > 183ms$ in STANDARD mode
 = $t_L/2$ when $t_L < 183ms$ in STANDARD mode
 = 70 μ s in FAST mode

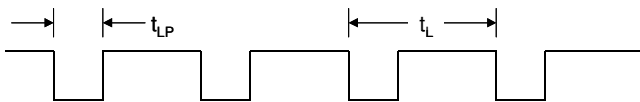

Figure 9: LED pulse output waveform

Motor Pulse Output (MON, MOP)

The MON and MOP pins are complimentary outputs with a frequency proportional to the average active power consumption measured. These active high outputs can be used to either directly drive a stepper motor counter or an electro-mechanical impulse counter. The Rated Condition Select inputs (RA, RB) as well as the Fast Mode Select input (FMS) allow the selection of different output frequencies corresponding to different meter constants. Figure 10 indicates the timing of these signals.

The nominal output frequency of each motor output is given by:

$$f_{MOT} = \frac{f_{LED_STD}}{DF_MO} \quad (5)$$

f_{LED_STD} = the output frequency of the LED output in STANDARD mode as per Equation 4 and

DF_MO = the motor divider selected by RA, RB and FMS according to Table 2.

When connecting a stepper motor counter between MON and MOP the output pulse rate is effectively doubled because the pulses on both MON and MOP contribute to incrementing the counter.

The timing values given below are based on the nominal frequency value of the internal oscillator.

t_M = $1/f_{MOT}$ (f_{MOT} as per Equation 5)

t_{MP} = 220ms when $t_M > 440ms$
 = $t_M/2$ when $t_M < 440ms$

t_{MS} = $t_M/2$

t_{MSP} = $t_{MS} - t_{MP}$ when $t_M > 440ms$
 = 7.8 μ s when $t_M < 440ms$

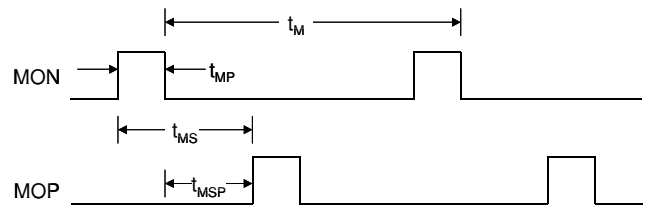

Figure 10: Motor pulse output waveform

Phase Direction Output (PH/DIR)

The PH/DIR output enables either direction or missing phase information on the multiplexed LED driver outputs (PH1, PH2 and PH3). This output pin switches between logic 0 and logic 1 at a frequency of approximately 110Hz. A logic 0 enables energy direction information and a logic 1 enables missing phase information on the LED driver outputs. The PH/DIR output is used in conjunction with the individual LED driver outputs to display information concerning each individual channel as illustrated in Figure 11. It is also used in conjunction with the RA, RB and MS inputs to set up the SA4301A.

LED Drivers (PH1, PH2, PH3)

When used in conjunction with the PH/DIR signal the LED driver outputs will indicate individual channel energy direction and individual channel missing phase conditions as follows:

PH/DIR = 1 (Voltage fail / phase sequence error): When PH/DIR is high (logic 1) the individual channel voltage information is available on the PH1, PH2 and PH3 pins. A logic 1 on any of these pins indicates the corresponding channels voltage is missing. This is based on the SA4301A not detecting a sufficiently large input current amplitude (approximately $1\mu A_{RMS}$) on the specific voltage sense input. The outputs will be set to logic 0 when the input current on the corresponding channel is larger than approximately $1\mu A_{RMS}$ thereby indicating that the corresponding phase voltage is present. Referring to Figure 11, the voltage LED for a specific channel will be activated when the phase voltage is present and de-activated when the phase voltage is missing. A power-on reset at start-up will set the voltage



fail indication for all channels to high (logic 1). Each missing phase LED will therefore be de-activated until a valid phase voltage is detected. In the case of a phase sequence error all three voltage fail LED driver outputs will pulse with a repetition rate of approximately 1Hz. A phase sequence error will only be indicated if three stable phase voltages are present. When the SA4301A detects a missing phase voltage on a specific channel that channel will be masked on the programmable adder, which means that any residual energy measured on that channel will not appear on the LED and motor outputs.

PH/DIR = 0 (Direction indication): When PH/DIR is low (logic 0) energy direction information for each individual channel is available on the PH1, PH2 and PH3 pins. A logic 1 on any of these pins indicates reverse energy flow for the specific channel and a logic 0 indicates positive energy flow. Reverse energy flow is defined as the condition where the

voltage and current input signals on a specific channel are out of phase (phase angle greater than 90 degrees), while positive energy flow is defined as the condition where the voltage and current input signals on a specific channel are in-phase (phase angle smaller than 90 degrees). Referring to Figure 11 the direction LED for a specific channel will be activated when the direction is negative and de-activated when the direction is positive. A power-on reset at start-up will set the direction indication for all channels to low (logic 0). The direction LEDs will therefore be turned off at start-up. Once negative energy has been detected on a specific channel the LED will turn on. If a missing phase voltage is detected on a specific channel or if the energy measured on that channel is below the anti-creep threshold the direction indication of that channel will default to logic 0, thereby also turning the direction LED of that channel off. If a phase sequence error is detected the direction outputs still indicate the energy direction detected on the specific channels.

ANTI-TAMPER FEATURES LED Array

The SA4301A caters for numerous meter tamper conditions, which are indicated by an LED array as follows:

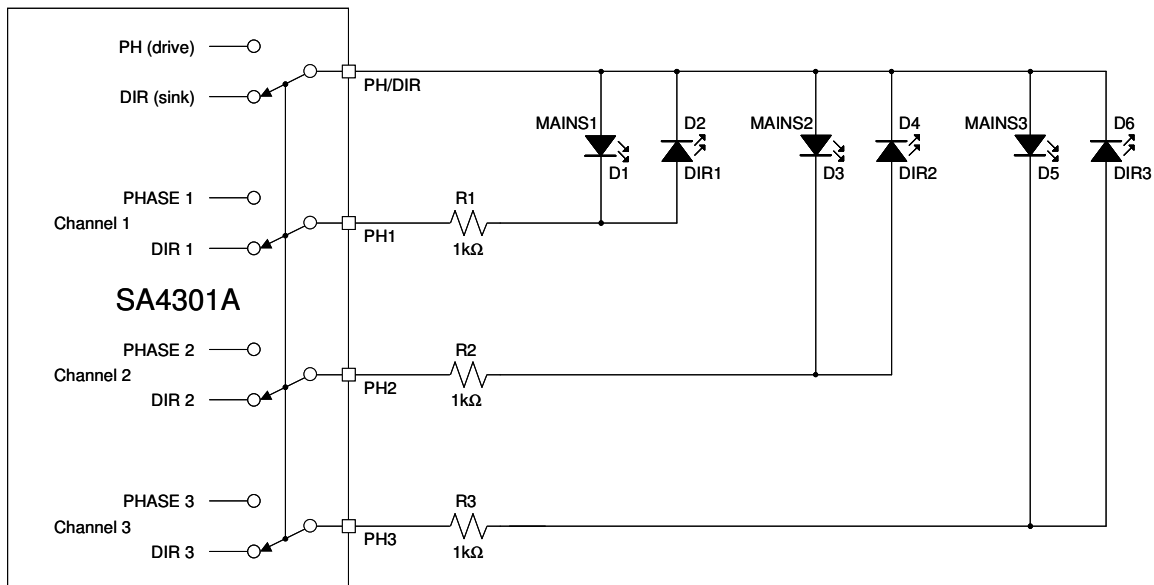

Figure 11: Multiplexing tamper LED array



Identifiable Tamper Conditions

The SA4301A caters for the following meter tamper conditions, which are indicated as follows:

Condition	Identification	Result
Phase Voltages	One LED is provided for each channel to indicate abnormal operating conditions.	During normal conditions, the LEDs are continuously switched on.
Phase Failure	In case of a phase failure, the corresponding phase voltage fail LED is switched off.	The SA4301A will record the energy consumption accurately under this condition.
Phase Sequence Error	In case of a phase sequence error, the phase voltage fail LEDs will flash with a repetition rate of approximately 1Hz.	The SA4301A will record the energy consumption accurately under this condition.
Input / Output Terminals Interchanged	One LED is provided for each channel to indicate reverse energy flow. If detected, the corresponding LED is switched on. The SA4301A can be configured to accumulate the absolute energy consumption measured for each channel, irrespective of the direction of the energy flow.	The SA4301A will record the energy consumption accurately and as defined by the setup of the programmable adder.
Missing Neutral Connection		The architecture of the meter should provide for a good "phantom neutral". In this case, the meter would register the energy consumption correctly.
Return through Earth	An indication for this condition could be realized external to the IC.	The input line currents are measured, so the SA4301A will therefore record the energy consumption accurately under this condition.
Load Imbalance		The SA4301A will record the energy consumption accurately under this condition.

Anti-Tamper Indicators

The operation of the tamper indication LED array is according to the following tables in order of increasing priority. In all cases the previous valid condition is retained unless substituted by a new higher priority valid tamper condition or normal operation. For example, assume a

missing phase is detected. The other two phase voltages are now reversed. This should cause a phase sequence error, a new valid tamper condition, but with a lower priority. Therefore the phase sequence error will not be indicated until the missing phase has been corrected.

Normal Operation Indication

Condition No.	Channel Input			MAINS LED Indicators			DIR LED Indicators		
	1	2	3	1	2	3	1	2	3
1	V&I_R	V&I_Y	V&I_B	ON	ON	ON	OFF	OFF	OFF
2	V&I_B	V&I_R	V&I_Y	ON	ON	ON	OFF	OFF	OFF
3	V&I_Y	V&I_B	V&I_R	ON	ON	ON	OFF	OFF	OFF

V&I_R, V&I_Y and V&I_B are stable phase voltages with corresponding in-phase currents ($-90^\circ < \text{phase angle} < 90^\circ$). The energy on each channel is above the anti-creep threshold

Phase Direction Error Indication

Condition No.	Channel Input			MAINS LED Indicators			DIR LED Indicators		
	1	2	3	1	2	3	1	2	3
1	-V&I_R	V&I_Y	V&I_B	ON	ON	ON	ON	OFF	OFF
2	V&I_R	-V&I_Y	V&I_B	ON	ON	ON	OFF	ON	OFF
3	V&I_R	V&I_Y	-V&I_B	ON	ON	ON	OFF	OFF	ON
4	-V&I_R	-V&I_Y	V&I_B	ON	ON	ON	ON	ON	OFF
5	-V&I_R	V&I_Y	-V&I_B	ON	ON	ON	ON	OFF	ON
6	V&I_R	-V&I_Y	-V&I_B	ON	ON	ON	OFF	ON	ON
7	-V&I_R	-V&I_Y	-V&I_B	ON	ON	ON	ON	ON	ON



Phase Direction Error Indication (Continued)

Condition No.	Channel Input			MAINS LED Indicators			DIR LED Indicators		
	1	2	3	1	2	3	1	2	3
8	-V&I_B	V&I_R	V&I_Y	ON	ON	ON	ON	OFF	OFF
9	V&I_B	-V&I_R	V&I_Y	ON	ON	ON	OFF	ON	OFF
10	V&I_B	V&I_R	-V&I_Y	ON	ON	ON	OFF	OFF	ON
11	-V&I_B	-V&I_R	V&I_Y	ON	ON	ON	ON	ON	OFF
12	-V&I_B	V&I_R	-V&I_Y	ON	ON	ON	ON	OFF	ON
13	V&I_B	-V&I_R	-V&I_Y	ON	ON	ON	OFF	ON	ON
14	-V&I_B	-V&I_R	-V&I_Y	ON	ON	ON	ON	ON	ON
15	-V&I_Y	V&I_B	V&I_R	ON	ON	ON	ON	OFF	OFF
16	V&I_Y	-V&I_B	V&I_R	ON	ON	ON	OFF	ON	OFF
17	V&I_Y	V&I_B	-V&I_R	ON	ON	ON	OFF	OFF	ON
18	-V&I_Y	-V&I_B	V&I_R	ON	ON	ON	ON	ON	OFF
19	-V&I_Y	V&I_B	-V&I_R	ON	ON	ON	ON	OFF	ON
20	V&I_Y	-V&I_B	-V&I_R	ON	ON	ON	OFF	ON	ON
21	-V&I_Y	-V&I_B	-V&I_R	ON	ON	ON	ON	ON	ON

V&I_R, V&I_Y and V&I_B are stable phase voltages with corresponding in-phase currents ($-90^\circ < \text{phase angle} < 90^\circ$). The energy on each channel is above the anti-creep threshold

-V&I_R, -V&I_Y and -V&I_B are stable phase voltages with corresponding out of phase currents ($-180^\circ < \text{phase angle} < -90^\circ$ or $90^\circ < \text{phase angle} < 180^\circ$). The energy on each channel is above the anti-creep threshold

Anti-Creep Operation

Condition No.	Channel Input			MAINS LED Indicators			DIR LED Indicators		
	1	2	3	1	2	3	1	2	3
1	v&i_r	V&I_Y	V&I_B	ON	ON	ON	OFF	X	X
2	V&I_R	v&i_y	V&I_B	ON	ON	ON	X	OFF	X
3	V&I_R	V&I_Y	v&i_b	ON	ON	ON	X	X	OFF
4	v&i_r	v&i_y	V&I_B	ON	ON	ON	OFF	OFF	X
5	v&i_r	V&I_Y	v&i_b	ON	ON	ON	OFF	X	OFF
6	V&I_R	v&i_y	v&i_b	ON	ON	ON	X	OFF	OFF
7	v&i_r	v&i_y	v&i_b	ON	ON	ON	OFF	OFF	OFF
8	v&i_b	V&I_R	V&I_Y	ON	ON	ON	OFF	X	X
9	V&I_B	v&i_r	V&I_Y	ON	ON	ON	X	OFF	X
10	V&I_B	V&I_R	v&i_y	ON	ON	ON	X	X	OFF
11	v&i_b	v&i_r	V&I_Y	ON	ON	ON	OFF	OFF	X
12	v&i_b	V&I_R	v&i_y	ON	ON	ON	OFF	X	OFF
13	V&I_B	v&i_r	v&i_y	ON	ON	ON	X	OFF	OFF
14	v&i_b	v&i_r	v&i_y	ON	ON	ON	OFF	OFF	OFF



Anti-Creep Operation (continued)

Condition No.	Channel Input			MAINS LED Indicators			DIR LED Indicators		
	1	2	3	1	2	3	1	2	3
15	v&i_y	V&l_B	V&l_R	ON	ON	ON	OFF	X	X
16	V&l_Y	v&i_b	V&l_R	ON	ON	ON	X	OFF	X
17	V&l_Y	V&l_B	v&i_r	ON	ON	ON	X	X	OFF
18	v&i_y	v&i_b	V&l_R	ON	ON	ON	OFF	OFF	X
19	v&i_y	V&l_B	v&i_r	ON	ON	ON	OFF	X	OFF
20	V&l_Y	v&i_b	v&i_r	ON	ON	ON	X	OFF	OFF
21	v&i_y	v&i_b	v&i_r	ON	ON	ON	OFF	OFF	OFF

V&l_R, V&l_Y and V&l_B are stable phase voltages and currents such that the energy measured on that channel is above the anti-creep threshold

v&i_r, v&i_y and v&i_b are stable phase voltages and currents such that the energy measured on that channel is below the anti-creep threshold

X indicates that the LED can be ON or OFF depending on the energy direction of that specific channel

Phase Sequence Error Indication

Condition No.	Channel Input			MAINS LED Indicators			DIR LED Indicators		
	1	2	3	1	2	3	1	2	3
1	V_R	V_B	V_Y	FLASH	FLASH	FLASH	X	X	X
2	V_B	V_Y	V_R	FLASH	FLASH	FLASH	X	X	X
3	V_Y	V_R	V_B	FLASH	FLASH	FLASH	X	X	X

V_R, V_Y and V_B are stable phase voltages

X indicates that the LED can be ON or OFF depending on the energy direction as measured by the SA4301A on that specific channel

Missing Phase Error Indication

Condition No.	Channel Input			MAINS LED Indicators			DIR LED Indicators		
	1	2	3	1	2	3	1	2	3
1	-	V	V	OFF	ON	ON	OFF	X	X
2	V	-	V	ON	OFF	ON	X	OFF	X
3	V	V	-	ON	ON	OFF	X	X	OFF
4	-	-	V	OFF	OFF	ON	OFF	OFF	X
5	-	V	-	OFF	ON	OFF	OFF	X	OFF
6	V	-	-	ON	OFF	OFF	X	OFF	OFF
7	-	-	-	OFF	OFF	OFF	OFF	OFF	OFF

V indicates a stable voltage is present

- indicates that the phase voltage is below the voltage detection threshold (approximately 1μA_{RMS})

X indicates that the LED can be ON or OFF depending on the energy direction of that specific channel



TYPICAL APPLICATION

The following description outlines the basic process required to design a typical three phase energy meter using the SA4301A. The meter is a 3-phase 4-wire meter capable of measuring 3x220V/60A/50Hz with a precision better than Class 1. The meter uses a stepper motor counter with 100imp/kWh and the calibration LED has a constant of 800imp/kWh.

The most important external circuits required for the SA4301A are the current input networks, the voltage input networks as well as the bias resistor. All resistors should be 1% metal film resistors of the same type to minimize temperature effects.

Bias Resistor

A bias resistor of $R_{34} = 47k\Omega$ sets optimum bias and reference currents on chip. Calibration of the meter should be done using the voltage inputs and not by means of the bias resistor.

Current Input Networks

Three current transformers are used to measure the three line currents. The output of each current transformer is terminated with a low impedance resistor split into two equal parts to obtain purely differential current input signals. The voltage across the termination resistors is converted to the required differential input currents through the current input resistors. Anti-alias filters are incorporated on these input resistors to filter any high frequency signal components that could affect the performance of the SA4301A.

The voltage drop across the current transformer termination resistors at maximum rated current should be in the order of 100mV_{RMS}. The current transformers have a low phase shift and a turns ratio of 1:2500. The value of the termination resistors R_1, R_2 is therefore

$$R_1 = R_2 = 100mV \times \frac{N_{CT}}{I_{MAX}} \times \frac{1}{2} \approx 2\Omega = R_B$$

where N_{CT} is the current transformer ratio (2500) and I_{MAX} is the maximum input current (60A).

The four current input resistors (R_3, R_4, R_5, R_6) should be of equal size to optimize the input networks low pass filtering characteristics, so the values can be calculated as follows:

$$R_3 = R_4 = R_5 = R_6 = \frac{I_{MAX}}{N_{CT}} \times \frac{R_B}{2 \times 16\mu A} = 1.5k\Omega = R_C$$

For optimum performance the cut-off frequency of the anti-alias filter should be between 10kHz and 20kHz. The equivalent resistance associated with each capacitor is $R_C/2$ so the capacitor values should be in the order of

$$C_1 = C_2 = \frac{1}{\pi f_{CI} R_C} = \frac{1}{\pi \times 10kHz \times 1.5k\Omega} \approx 22nF = C_C$$

where f_{CI} is the cut-off frequency of the anti-alias filter of the current input network.

The current input networks for channel 2 and channel 3 are identical.

Voltage Input Networks

The voltage sense inputs require an input current of 11μA_{RMS} at V_{NOM} (220V) according to Table 1. The mains voltage is divided by means of a voltage divider to a lower voltage that is converted to the required input current by means of the input resistor. Once again an anti-alias filter is required to remove any high frequency signals that could affect the performance of the SA4301A. The phase shift of the current transformers is compensated by means of this anti-alias filter as well, by purposefully increasing the cut-off frequency.

The input resistor R_{22} sets the current input into the device. This resistor should not be too large else the capacitor for the anti-alias filter will be quite small which could cause inaccurate phase shift due to parasitic capacitances. Therefore $R_{22} = 100k\Omega$ is chosen and the voltage at the centre of the trimpot should be 1.1V ($11\mu A \times 100k\Omega$). The calibration range of the voltage input network should be about ±15% to ensure that all component tolerances can be catered for, so the total tuning range can be set to ±0.17V. Therefore the voltage across the trimpot and R_{23} is 1.27V. Choosing a 1kΩ trimpot results in

$$R_{23} = \frac{1k\Omega}{(2 \times 0.17)} \times (1.27 - 2 \times 0.17) \approx 2.7k\Omega$$

The effect of R_{22} can be ignored in the above equation, given the fact that R_{22} is significantly larger than P_1 and R_{23} . Now let $R_A = R_{19} + R_{20} + R_{21}$ and

$$R_A = (P_1 + R_{23}) \times \left(\frac{220V}{1.27V} - 1 \right) \approx 637k\Omega$$

so choose $R_{19} = 240k\Omega$, $R_{20} = 220k\Omega$ and $R_{21} = 180k\Omega$.



The cut-off frequency of the anti-alias filter is adjusted so that the phase shift of the voltage input network is identical to the sum of the phase shifts of the current transformer and the current input network. The phase shift of the current input network is

$$\phi_{II} = -\arctan(\pi R_C C_C \times 50\text{Hz}) \approx -0.297 \text{ degrees}$$

The phase shift required on the voltage input network is therefore

$$\phi_{IV} = \phi_{II} + \phi_{CT} = -0.297 + 0.09 = -0.207$$

where ϕ_{CT} is the phase shift of the current transformer which is typically about 0.09 degrees for a good quality current transformer. Neglecting R19, R20, R21 and R22 because all these resistors are significantly larger than P1 and R23 the capacitance required to achieve the -0.207 degree phase shift is

$$C7 = \frac{|\tan \phi_{IV}|}{2\pi(P1 + R23) \times 50\text{Hz}} \approx 3.3\text{nF}$$

resulting in a cut-off frequency of

$$f_{CV} = \frac{1}{2\pi(P1 + R23) \times C7} \approx 13\text{kHz}$$

The value of the cut-off frequency of the voltage input network is less critical than that of the current input network because the dynamic range of the voltage input is small. A cut-off frequency between 10kHz and 25kHz is acceptable.

The voltage input networks for channel 2 and channel 3 are identical

Device Setup

The SA4301A has to be set to STANDARD mode. Using Equations 1 and 2 in the Rated Condition Select section the required LED and motor dividers for 800imp/kWh and 100imp/kWh respectively are calculated as DF_LED = 392 and DF_MO = 8. Using Table 2 the device is set up using FMS = V_{DD}, RA = V_{SS} and RB is left floating. To achieve maximum immunity to tampering the device is set to absolute sum mode by setting MS to V_{DD}.

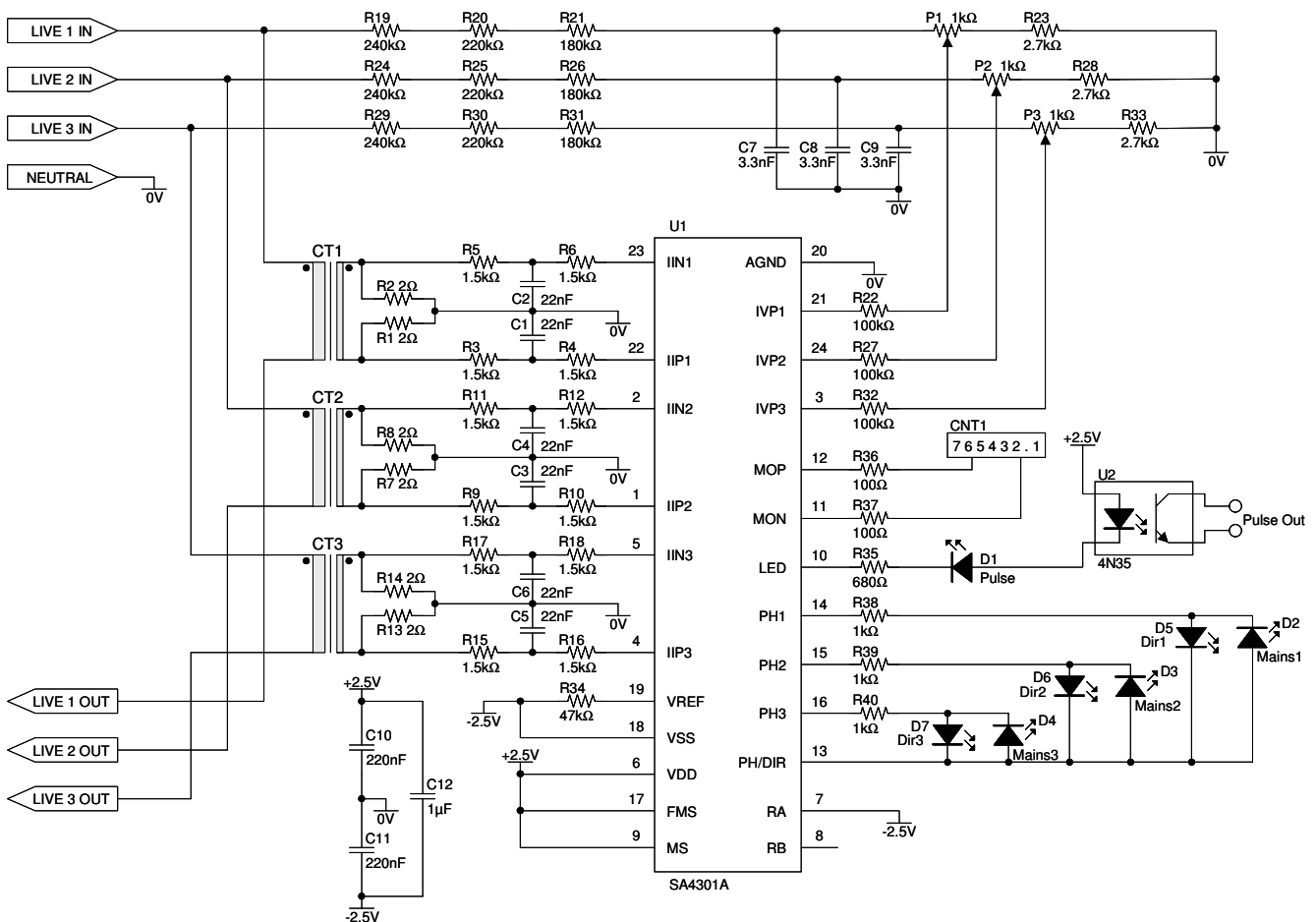

Figure 12: Typical application circuit



Table 6: Component list for typical application

Symbol	Description
U1	Energy metering device, SA4301ASAR
U2	Opto-coupler, 1N35
R1, R2	Resistor, 2Ω, 1%, metal film
R3, R4 ¹ , R5, R6 ¹	Resistor, 1.5kΩ, 1%, metal film
R7, R8	Resistor, 2Ω, 1%, metal film
R9, R10 ¹ , R11, R12 ¹	Resistor, 1.5kΩ, 1%, metal film
R13, R14	Resistor, 2Ω, 1%, metal film
R15, R16 ¹ , R17, R18 ¹	Resistor, 1.5kΩ, 1%, metal film
R19, R24, R29	Resistor, 240kΩ, 1%, metal film
R20, R25, R30	Resistor, 220kΩ, 1%, metal film
R21, R26, R31	Resistor, 180kΩ, 1%, metal film
R22 ¹ , R27 ¹ , R32 ¹	Resistor, 100kΩ, 1%, metal film
R23, R28, R33	Resistor, 2.7kΩ, 1%, metal film
R34 ¹	Resistor, 47kΩ, 1%, metal film
R35	Resistor, 680Ω, 5%, carbon film
R36, R37	Resistor, 100Ω, 5%, carbon film
R38, R39, R40	Resistor, 1kΩ, 5%, carbon film
P1, P2, P3	Trim-pot, 25 turns, 1kΩ
C1, C2	Capacitor, 22nF, ceramic
C3, C4	Capacitor, 22nF, ceramic
C5, C6	Capacitor, 22nF, ceramic
C7, C8, C9	Capacitor, 3.3nF, ceramic
C10 ² , C11 ²	Capacitor, 220nF, ceramic
C12 ²	Capacitor, 1μF, ceramic
D1	Light emitting diode, pulse output
D2, D3, D4	Light emitting diode, mains voltage output
D5, D6, D7	Light emitting diode, energy direction output
CT1, CT2, CT3	Current transformer, 60A, 1:2500
CNT1	Stepper motor counter, 100imp/kWh

Note 1: Resistors R4, R6, R10, R12, R16, R18, R22, R27, R32 and R34 must be positioned as close as possible to the respective device pins

Note 2: Capacitors C10, C11 and C12 must be positioned as close as possible to the V_{DD} and V_{SS} power supply pins



PACKAGE DIMENSIONS

SOIC24 Package

Dimensions are shown in inches

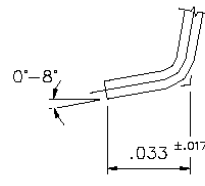
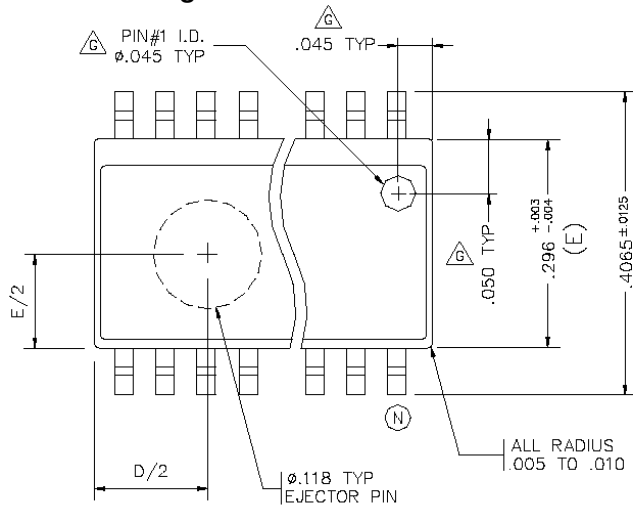

N	D VARIATIONS		
	MIN	NOM	MAX
16	.398	.405	.412
18	.449	.456	.463
20	.496	.503	.510
24	.599	.606	.613
28	.697	.704	.711

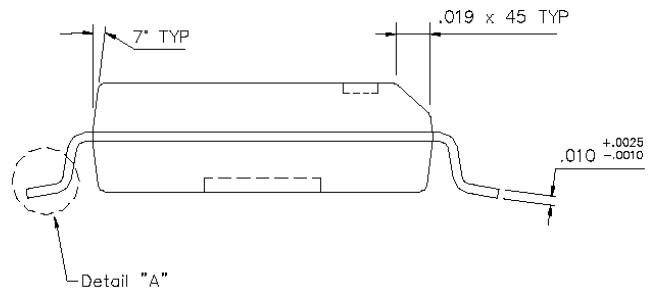
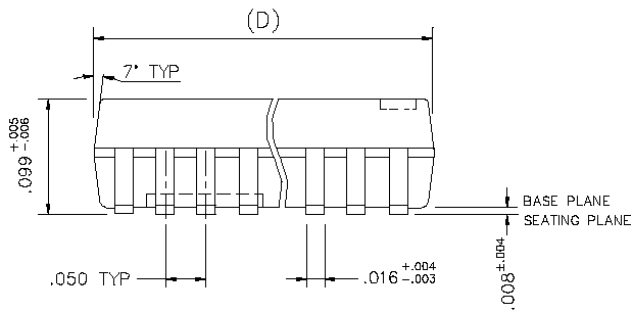



NOTES

**DISCLAIMER**

The information contained in this document is confidential and proprietary to Integrated Circuit Design Centre (Pty) Ltd ("ICDC"), a division of South African Micro-electronic Systems (Pty) Ltd ("SAMES"), and may not be copied or disclosed to a third party, in whole or in part, without the express written consent of ICDC. The information contained herein is current as of the date of publication; however, delivery of this document shall not under any circumstances create any implication that the information contained herein is correct as of any time subsequent to such date. ICDC does not undertake to inform any recipient of this document of any changes in the information contained herein, and ICDC expressly reserves the right to make changes in such information, without notification, even if such changes would render information contained herein inaccurate or incomplete. ICDC makes no representation or warranty that any circuit designed by reference to the information contained herein, will function without errors and as intended by the designer.

Any sales or technical questions may be posted to our e-mail address below:
support@sames.co.za

For the latest updates on datasheets, please visit our web site:
<http://www.sames.co.za>

INTEGRATED CIRCUIT DESIGN CENTRE (PTY) LTD
a division of
SOUTH AFRICAN MICRO-ELECTRONIC SYSTEMS (PTY) LTD

Tel: (012) 333-6021
Tel: Int +27 12 333-6021
Fax: (012) 333-6393
Fax: Int +27 12 333-6393

P O BOX 15888
LYNN EAST 0039
REPUBLIC OF SOUTH AFRICA

33 ELAND STREET
KOEDOESPOORT INDUSTRIAL AREA
PRETORIA
REPUBLIC OF SOUTH AFRICA