

SA5694

ACTUATOR DRIVER WITH CURRENT FEEDBACK FOR CD – ROM / DVD

DESCRIPTION

The SA5694 is a four-channel BTL driver IC for driving the motors and actuators in products such as CD - ROM / DVD drivers. Two of the channels use current feedback to minimize the current phase shift caused by the influence of load inductance.

FEATURE

1. Wide dynamic range (4.0V (typ.) when VCC = 12V, PVCC =5V, and RL = 8Ω).
2. Level shift circuit on chip.
3. Thermal shutdown circuit on chip.

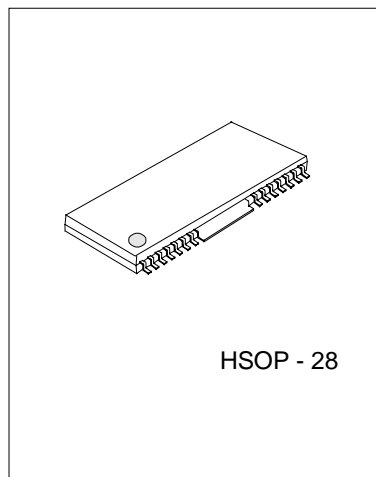

APPLICATION

CD-ROM, DVD

PIN CONFIGURATION

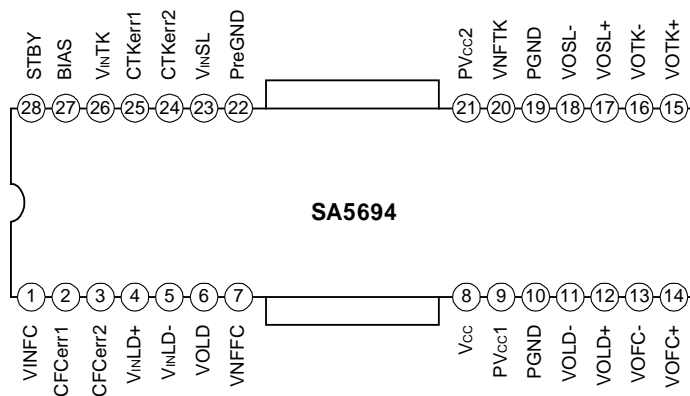

HANGZHOU SILAN MICROELECTRONICS JOINT-STOCK CO.,LTD

Rev: 2.1 2002-5-21

BLOCK DIAGRAM

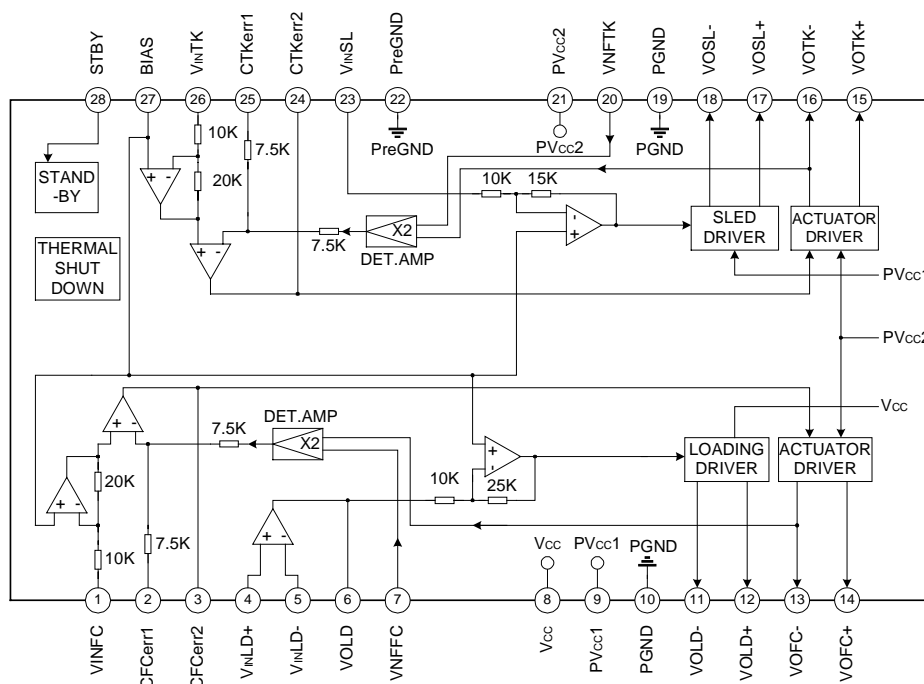

ABSOLUTE MAXIMUM RATING (Tamb=25°C)

Characteristics	Symbol	Value	Unit
Power Supply Voltage	VCC, PVCC1/2	13.5	V
Power Dissipation	PD	1.7*	W
Operating Temperature	Topr	-35~+85	°C
Storage Temperature	Tstg	-55~+150	°C

*When mounted on a 70mm X 70mm X 1.6mm glass epoxy board.

Reduced by 13.6mW for each increase in Tamb of 1°C over 25°C

RECOMMENDED OPERATING CONDITIONS (Tamb = 25°C)

Parameter	Symbol	Value	Unit
Power Supply Voltage	VCC	4.3~13.2	V
	PVCC1	4.3~VCC	V
	PVCC2	4.3~VCC	V

— HANGZHOU SILAN MICROELECTRONICS JOINT-STOCK CO.,LTD —

Rev: 2.1 2002-5-21

ELECTRICAL CHARACTERISTICS(unless other specified, $T_{amb}=25^{\circ}\text{C}$, $V_{CC}=12\text{V}$, $PV_{CC1}=PV_{CC2}=5\text{V}$, $\text{BIAS}=2.5\text{V}$, $R_L=8\Omega$, $R_d=0.5\Omega$, $C=100\text{pF}$)

Characteristics	Symbol	Test conditions	Min.	Typ.	Max.	Unit
Quiescent Current	I_{CC}		--	18	27	mA
Actuator Driver						
Output Offset Current	I_{OOF}		-6	--	6	mA
Maximum Output Amplitude	V_{OM}		3.6	4.0	--	V
Transmission Gain	GM	$V_{IN}=\text{BIAS} \pm 0.2\text{V}$	1.3	1.5	1.7	A/V
Loading Driver						
Input op-amp Same Phase Input Range	V_{ICM}		-0.3	--	11.0	V
Input Bias Current (outflow current)	I_{BOP}		--	30	300	nA
Output High Level Voltage	V_{OHOP}	No load	10.8	11.1	--	V
Output Low Level Voltage	V_{OLOP}	No load	--	0.8	1.1	V
Output Offset Voltage	V_{OFLD}		-100	0	100	mV
Maximum Output Amplitude	V_{OMLD}		7.5	9.0	--	V
Closed-circuit Voltage Gain	$GVLD$	$V_{IN}=\text{BIAS} \pm 0.2\text{V}$	18.0	20.0	22.0	dB
Sled Driver						
Offset Voltage	V_{OOFSL}		-50	0	50	mV
Maximum Output Amplitude	V_{OMSL}		3.6	4.0	--	V
Voltage Gain	$GVSL$	$V_{IN}=\text{BIAS} \pm 0.2\text{V}$	13.5	15.5	17.5	dB
F/R Gain Differential	$\Delta GVSL$	$V_{IN}=\text{BIAS} \pm 0.2\text{V}$	0	1	2	dB
STBY Logic						
STBY On Voltage	V_{STBY1}	All Channels Off	0	--	0.5	V
STBY Off Voltage	V_{STBY2}	All Channels On	2.0	--	--	V

PIN DESCRIPTIONS

Pin No.	Pin Name	Function
1	V_{INFC}	Focus driver input
2	$CFCerr1$	For connection of capacitor for the error amp filter
3	$CFCerr2$	For connection of capacitor for the error amp filter
4	V_{INLD+}	Op-amp input (+) for the Loading driver
5	V_{INLD-}	Op-amp input (-) for the Loading driver
6	V_{OLD}	Op-amp output for the Loading driver
7	V_{NFFC}	Focus driver feedback pin
8	V_{CC}	V_{CC}
9	PV_{CC1}	Power V_{CC} for sled driver block

(To be continued)

— HANGZHOU SILAN MICROELECTRONICS JOINT-STOCK CO.,LTD —

Rev: 2.1 2002-5-21

(Continued)

Pin No.	Pin Name	Function
10	PGND	Power ground
11	VOLD-	Loading driver output (-)
12	VOLD+	Loading driver output (+)
13	VOFC-	Focus driver output (-)
14	VOFC+	Focus driver output (+)
15	VOTK+	Tracking driver output (+)
16	VOTK-	Tracking driver output (-)
17	VOSL+	Sled driver output (+)
18	VOSL-	Sled driver output (-)
19	PGND	Power ground
20	VNFTK	Tracking driver feedback pin
21	PVCC2	Power VCC 2
22	PreGND	Pre ground
23	VINSL	Sled driver input
24	CTKerr2	For connection of capacitor for the error amp filter
25	CTKerr1	For connection of capacitor for the error amp filter
26	VINTK	Tracking driver input
27	BIAS	Bias input
28	STBY	Standby

Notes: The indicated polarities for the output pins are for when all inputs are (+).

The output H bridge power supply pins are PVCC2 for the focus, tracking, PVCC1 for the sled channel, and VCC for the pre-block and Loading channel

Always ensure that $VCC \geq PVCC$

Operation notes

- (1) This IC has a built in thermal shutdown circuit that mutes the output current when the chip temperature reaches 175°C (typ.). The hysteresis is set to 25 °C (typ.), so the driver circuits start up again when the chip temperature falls to 150° C (typ.).
- (2) The driver buffer is switched off when the supply voltage falls below 3.5V (typ.), and is switched back on when the voltage reaches 3.7V (typ.) again.
- (3) The stand by circuit logic is active low.
- (4) Mute is applied when the buffer pin voltage falls below 1.4V (typ.). Normally, operate with this pin at 1.8V at least.
- (5) Connect a bypass capacitor between the bases of the power supply pins of this IC.

Supplement :(Current-feedback driver)

The transmission gain (output current/input voltage) is given by: $gm = \frac{1}{R_d + RWIRE} (A/V)$

RWIRE is the total gold wire resistance inside the package (0.15Ω±0.05Ω) (typ.).

———— **HANGZHOU SILAN MICROELECTRONICS JOINT-STOCK CO.,LTD** ————

Rev: 2.1 2002-5-21

ELECTRICAL CHARACTERISTICS CURVES

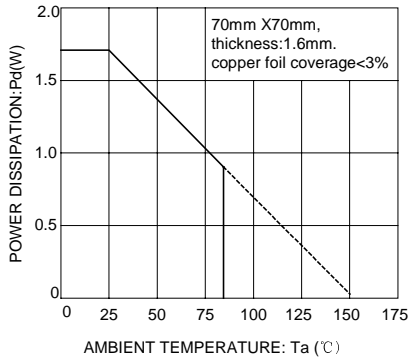

Fig 1. Thermal dissipation curve

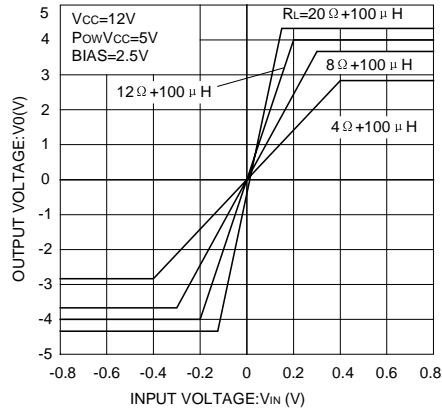

Fig 2. Driver I/O characteristics (focus and tracking)

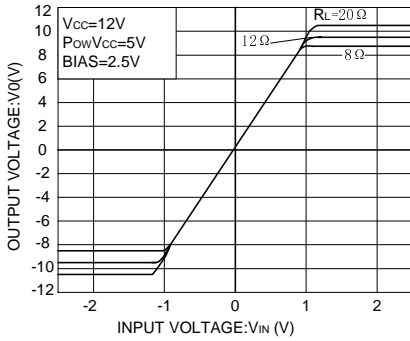

Fig 3. Driver I/O characteristics (Loading)

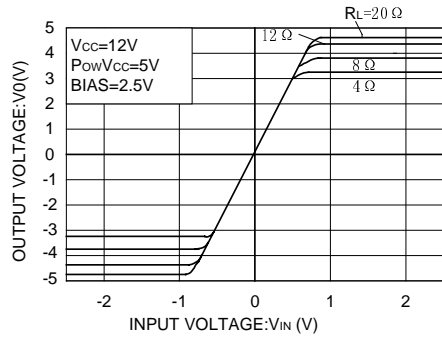

Fig 4. Driver I/O characteristics (slew)

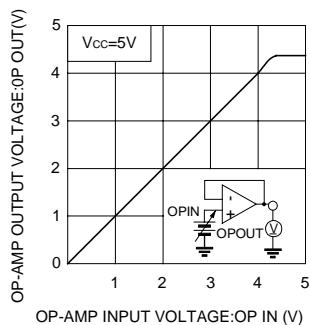

Fig 5. Op-amp I/O characteristics

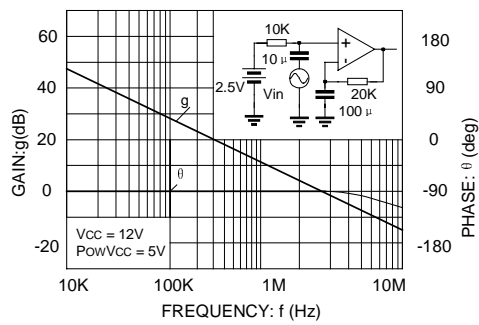
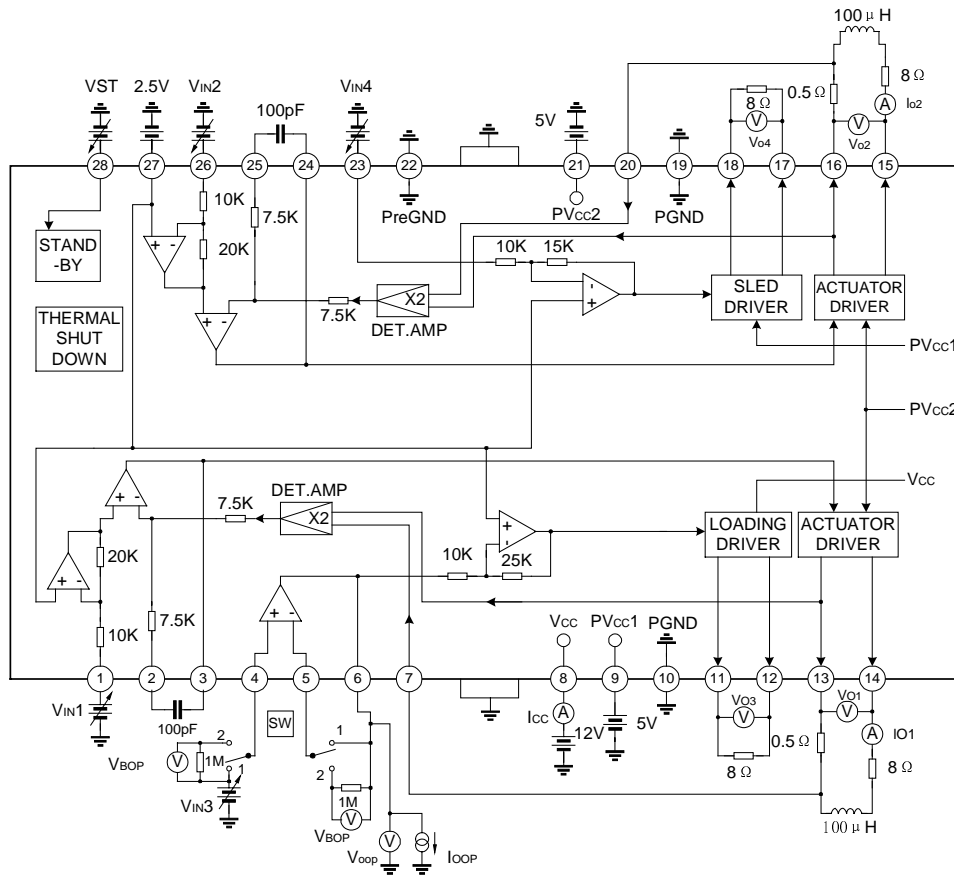

Fig 6. Op-amp phase-frequency, amplitude-frequency characteristics

TEST CIRCUIT



— HANGZHOU SILAN MICROELECTRONICS JOINT-STOCK CO.,LTD —

Rev: 2.1 2002-5-21

TYPICAL APPLICATION CIRCUIT

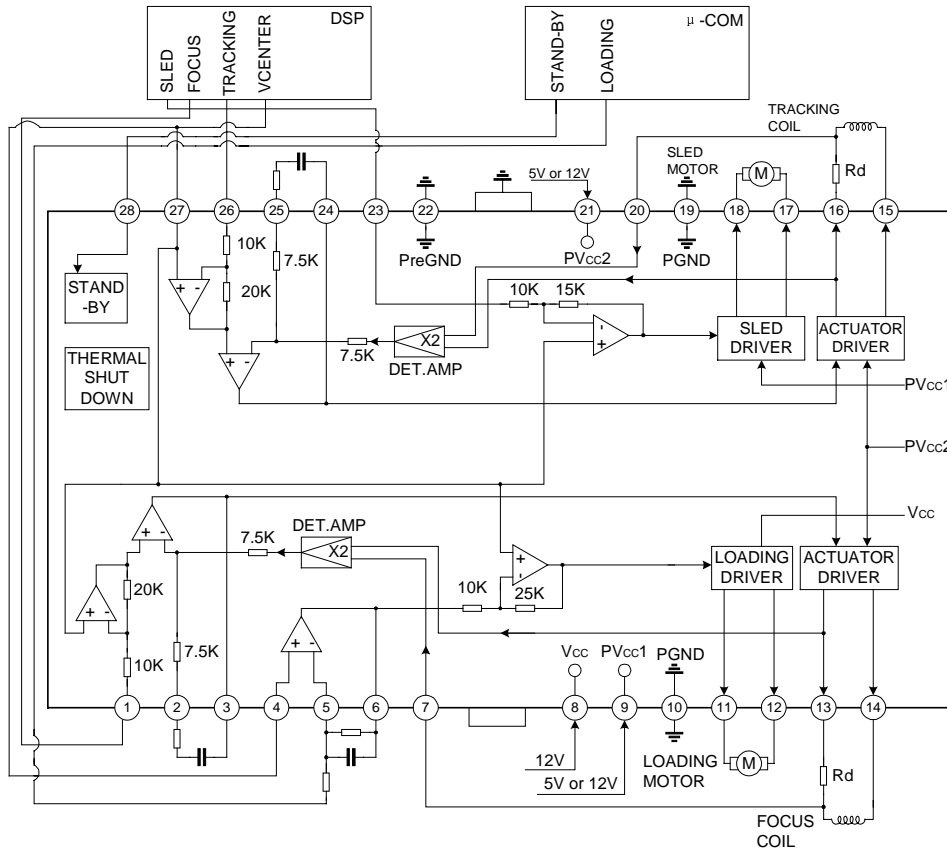

— HANGZHOU SILAN MICROELECTRONICS JOINT-STOCK CO.,LTD —

Rev: 2.1 2002-5-21

PACKAGE OUTLINE

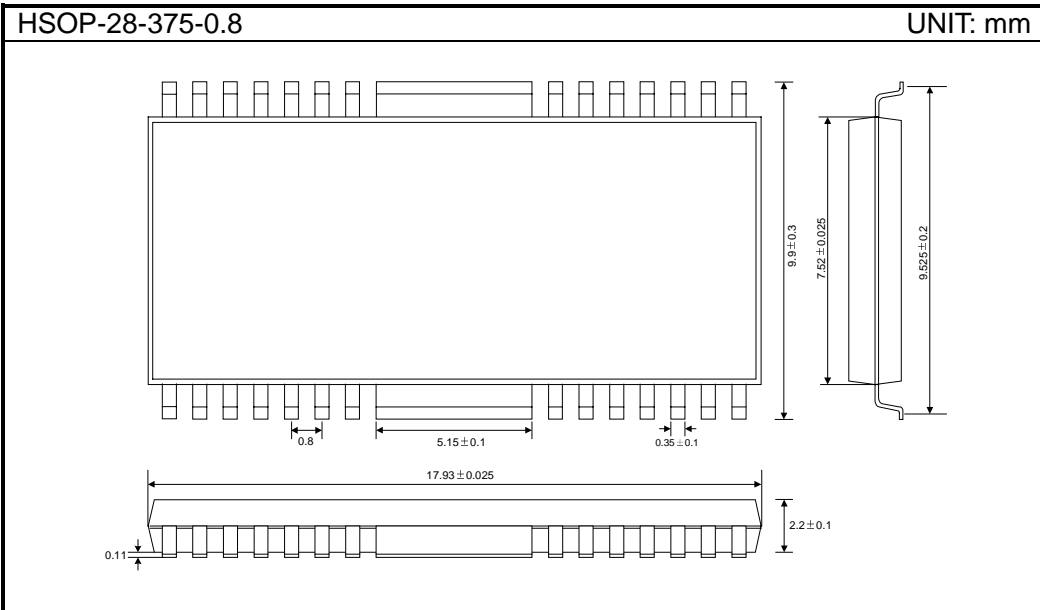

— HANGZHOU SILAN MICROELECTRONICS JOINT-STOCK CO.,LTD —

Rev: 2.1 2002-5-21

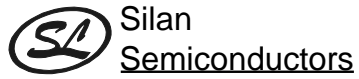

SA5694

Attach

Revision History

Data	REV	Description	Page
2001.12.24	2.0	Original	
2002.05.21	2.1	The "SA5954" change to the "SA5694"	

—— HANGZHOU SILAN MICROELECTRONICS JOINT-STOCK CO.,LTD ——

Rev: 2.1 2002-5-21