

5-CHANNEL CD/DVD MOTOR DRIVER WITH POWER DOWN CONTROL

DESCRIPTION

The SA5810 is a 5-channel motor driver for CD/CD-ROM/VCD/DVD system. It is composed of 2-CH BTL driver with 2-input OPAMP, 2-CH BTL driver and 1-CH forward/reverse controlled DC motor driver. Built-in power save controller can reduce the power consumption.

FEATURES

- * Built-in thermal shut down circuit.
- * Wide dynamic range of BTL driver.
(4V (TYP.) at PREVCC=12V, POWVCC=5V)
- * 4-channels BTL driver, there into 2 channels have amplifier.
- * Use motor controller controls the output of motor driver.
- * Built-in power save circuit.

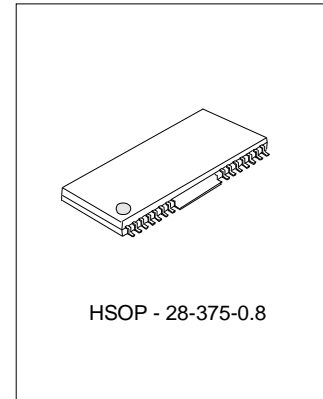

ORDERING INFORMATION

Device	Package
SA5810	HSOP-28-375-0.8

APPLICATIONS

- * CD players, CD-ROM drives, and other optical disc devices

BLOCK DIAGRAM

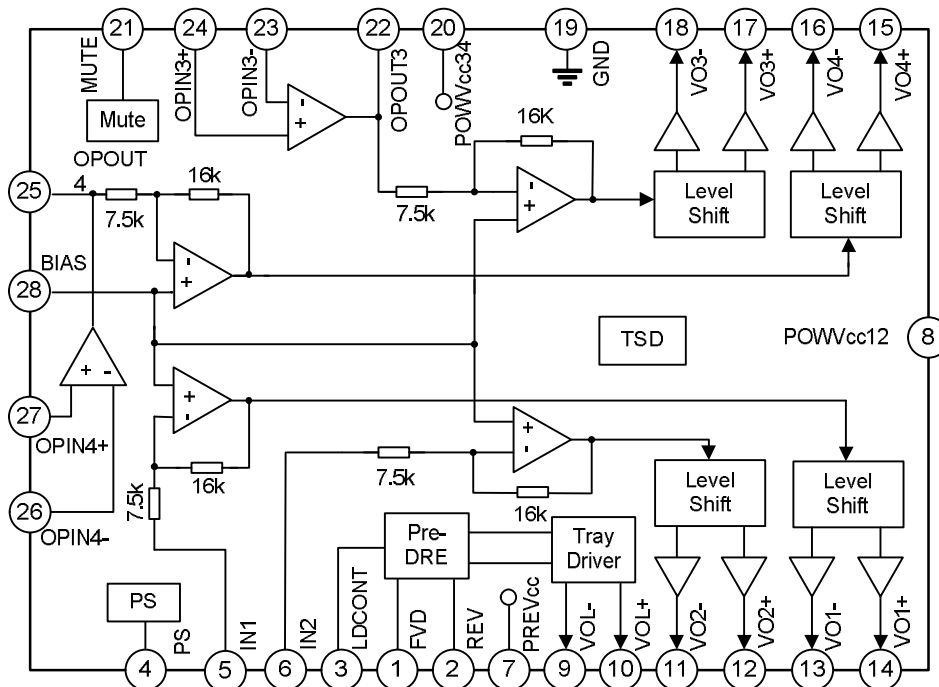

ABSOLUTE MAXIMUM RATINGS (T_{amb}=25°C)

Characteristics	Symbol	Value	Unit
Power Supply Voltage	PREVCC, POWVCC	13.5	V
Power Dissipation	P _d	1.7 (note)	W
Operating Temperature Range	T _{opr}	-40~+85	°C
Storage Temperature Range	T _{stg}	-55~ +150	°C

Note: When mounted on a 70mm x 70mm x 1.6mm glass epoxy board with copper foil coverage of less than 3%, reduced by 13.6mW for each increase in Temp of 1°C over 25°C.

RECOMMENDED OPERATING CONDITIONS (T_{amb}=25°C)

Characteristics	Symbol	Min.	Typ.	Max.	Unit
Power Supply	PREVCC	4.3	--	13.2	V
	POWVCC	4.3	--	PREVCC	V

ELECTRICAL CHARACTERISTICS

(Unless specified, T_{amb} = 25°C, PREVCC = 12V, POWVCC12, 34 = 5V, BIAS = 1.65V, R_L = 8Ω)

Characteristics	Symbol	Test Conditions	Min.	Typ.	Max.	Unit
Power						
Current at No Signal	I _{CC}	No load	--	22.9	34	mA
Current at Power Save	I _{PS}	PS="L"	--	1.65	2.8	mA
Voltage at Power Save On	V _{PS ON}	--	--	--	0.5	V
Voltage at Power Save Off	V _{PS OFF}	--	2.0	--	--	V
BTL driver						
Output Offset Voltage	V _{OO}	--	-50	0	50	mV
Maximum Output Amplitude	V _{OM}	--	3.6	4.0	--	V
Voltage Gain	G _{VC}	--	17.2	19.0	20.8	dB
Mute on Voltage	V _{MTON}	--	--	--	0.5	V
Mute off Voltage	V _{MTOFF}	--	1.5	--	--	V
Input Mute Current	I _{MUTE}	Mute Voltage = 5V	--	180	270	μA
Input Bias Current	I _{BIAS}	BIAS=2.5V	--	75	120	μA
Pre-operational Amplifier(ch3 and ch4)						
Input Common Mode Voltage	V _{ICM}	--	0.5	--	10.0	V
Input Offset Voltage	V _{OFOF}	--	-6	0	6	mV
Input Bias Current	I _{BOP}	--	--	--	300	nA
Output High Voltage	V _{OHO}	BIAS=6V, no load.	11.5	--	--	V
Output Low Voltage	V _{OLO}	BIAS=6V, no load.	--	--	0.5	V
Output Drive Current (Sink)	I _{SIN}	--	1	--	--	mA
Output Drive Current (Source)	I _{SOU}	--	1	--	--	mA

(To be continued)

(Continued)

Characteristics	Symbol	Test Conditions	Min.	Typ.	Max.	Unit
Slew Rate	SROP	100KHz square wave, 2VPP output	--	1	--	V/μs
Loading driver						
Output Saturation Voltage1	VSAT1	Upper +lower IL =200mA	0.7	1.1	1.5	V
Output Saturation Voltage 1 F/R Differential	ΔVSAT1	Output saturation voltage 1 F/R differential	--	--	0.1	V
Output Saturation Voltage 2	VSAT2	Upper +lower IL =500mA	1.0	1.55	2.2	V
Output "H" Voltage Gain	GVH	Upper Output/input	7.4	9.2	11	dB
Logical input (motor driver)						
Input High Voltage	VIHLD	--	1.5	--	VCC	V
Input Low Voltage	VILLD	--	-0.3	--	0.5	V
Input Current	IIHLD	VFWD=VREV =5V	--	180	270	μA

PIN CONFIGURATION

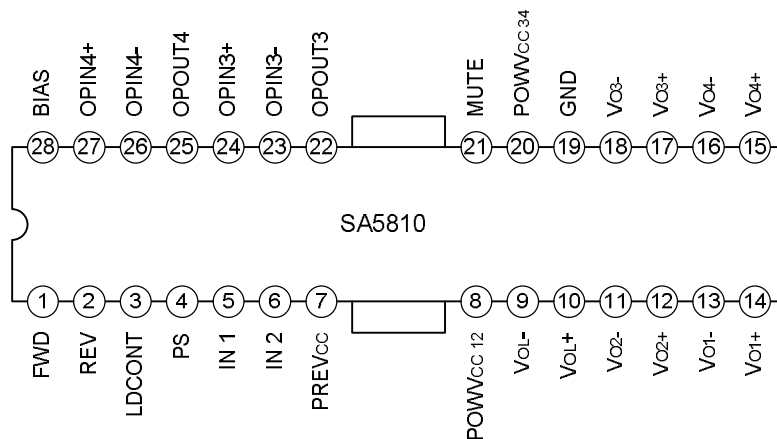

PIN DESCRIPTIONS

Pin No	Pin name	I/O	Pin Description
1	FWD	I	Tray forward input pin
2	REV	I	Tray reverse input pin
3	LDCONT	I	Loading control pin
4	PS	I	Power save pin
5	IN1	I	Channel 1 input pin
6	IN2	I	Channel 2 input pin
7	PREVCC	I/O	PREVCC and loading driver power
8	POWVCC 12	I/O	POWVCC (ch1 and ch2)
9	VOL -	O	Loading driver negative output

(To be continued)

(Continued)

Pin No	Pin name	I/O	Pin Description
10	VOL +	O	Loading driver positive output
11	VO2 -	O	Driver channel 2 negative output
12	VO2 +	O	Driver channel 2 positive output
13	VO1 -	O	Driver channel 1 negative output
14	VO1 +	O	Driver channel 1 positive output
15	VO4 +	O	Driver channel 4 positive output
16	VO4 -	O	Driver channel 4 negative output
17	VO3 +	O	Driver channel 3 positive output
18	VO3 -	O	Driver channel 3 negative output
19	GND	I/O	Ground
20	POWVCC34	I/O	POWVCC (ch3 and ch4)
21	MUTE	I	Mute control pin
22	OPOUT3	I/O	Channel 3 pre-amplifier output pin
23	OPIN3 -	I	Channel 3 pre-amplifier inverse input
24	OPIN3 +	I	Channel 3 pre-amplifier non-inverse input
25	OPOUT4	I/O	Channel 4 pre-amplifier output pin
26	OPIN4 -	I	Channel 4 pre-amplifier inverse input
27	OPIN4 +	I	Channel 4 pre-amplifier non-inverse input
28	BIAS	I	Bias input pin

Note: Positive output and negative output are the polarities with respect to the input. (For example, if pin5 voltage is high, then pin 14 voltages become high.)

FUNCTION DESCRIPTION

- 1) This IC has a built in thermal shutdown circuit that mutes the output current when the chip temperature reaches 175(°C (typ.)). The hysteresis is set to 25 (°C (typ.)), so the driver circuits start up again when the chip temperature falls to 150(°C (typ.)).
- 2) The driver buffer is switched off when the supply voltage falls below 3.8V (typ.), and is switched back on when the voltage reaches 4.0V (typ.) again.
- 3) Bias pin (pin28) should be pulled up to more than 1.1V. In case the bias pin voltage is pulled down below 0.7V (Typ), the output current is muted.
- 4) Mute is applied when the mute pin voltage falls below 0.5V (typ.). Normally, operate with this pin at 1.5V at least.
- 5) If the power supply is too low, the internal thermal shutdown circuit will mute the driver. When the mute on, and bias voltage is low, BTL driver (except loading driver) will mute, but the pre-amplifier will not mute at anytime. When muting occurs, the output voltage of BTL driver is POWVCC/2V.
- 6) Loading driver input logic truth table

FWD (1pin)	REV (2pin)	VOL+ (10pin)	VOL- (9pin)	Function
L	L	OPEN	OPEN	Open
L	H	H	L	REV
H	L	L	H	FWD
H	H	L	L	Play

The design of 1,2 pin, consider the driver upper and lower unable ducting at the same time, be sure to do it, the motor forward and reverse input by the open mode, and the interval of the open mode is more than 10ms.

Output high level voltage (VOL+, VOL-), varied with the motor controller, it can output 3 times voltage of 3 pin, and in high level. In this time, the low level voltage input power pipe as the output saturation voltage.

TEST CIRCUIT

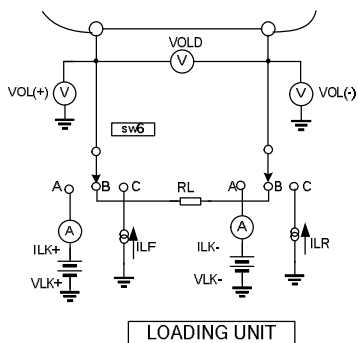
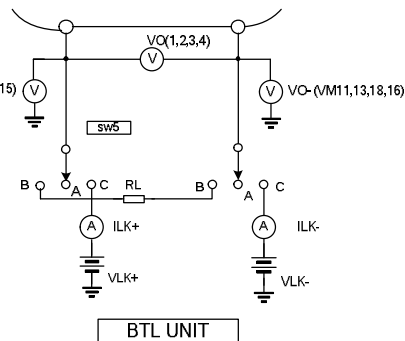
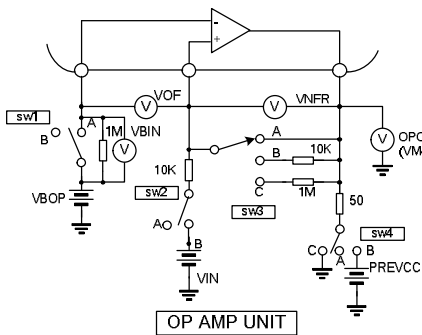
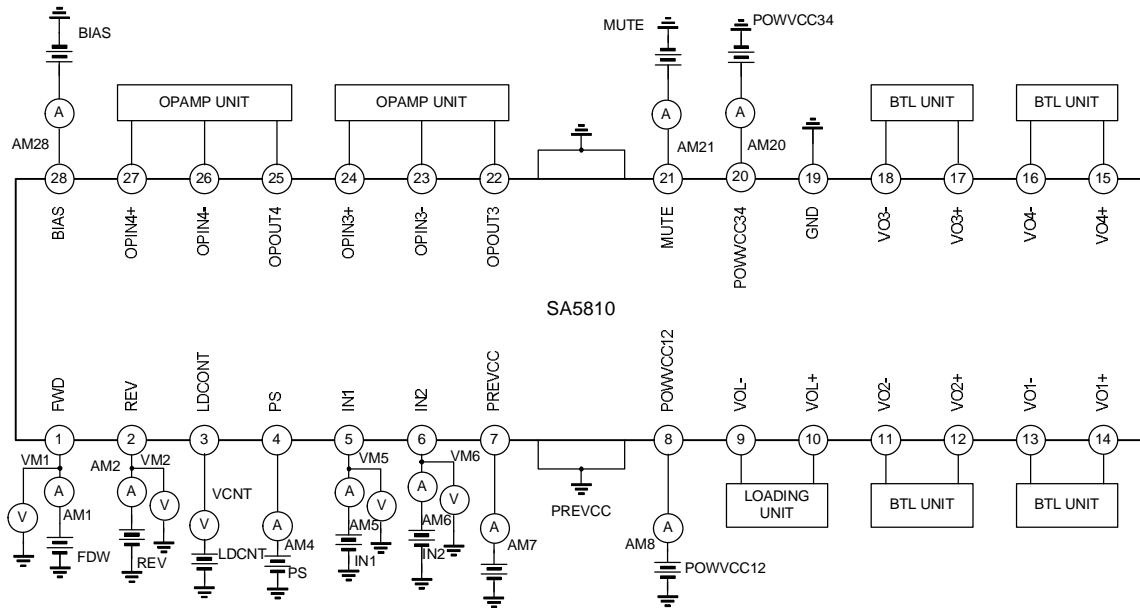

TYPICAL APPLICATION CIRCUITS

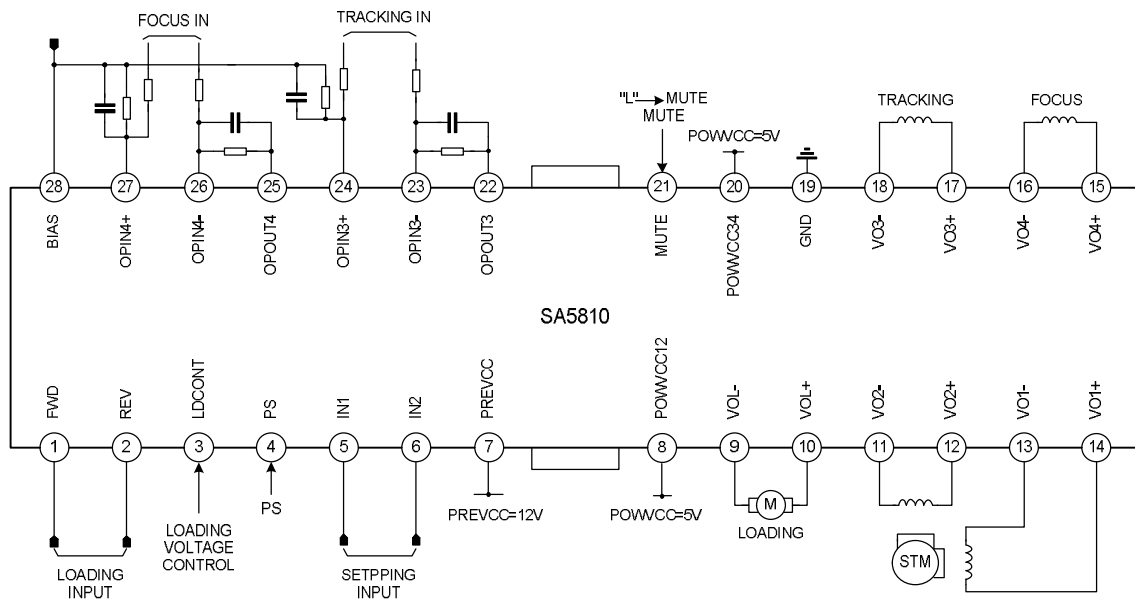

Note:

1. When supply the power, please tune up the IC to pulse kon (0.1 μ F).
2. Even though the radiation fins are connected to ground within the package, be sure to also connect them to a ground externally as well.
3. When use the PREVCC, POWVCC12 or POWVCC34 separately, the POWVCC12 and POWVCC34 cannot exceed the PREVCC.
4. Generally, we should avoid lettering at the pins whose voltage is lower than SUB voltage, because the loading driver causes the "inverse voltage"; when the SUB voltage is lower than the ground, should consider the margin problem.
5. In the circuit, should avoid the short circuit between the output pin and POWVCC pin, or output pin and the ground pin. When assemble the circuit to bias board, must be attention the position/direction of circuit, if the circuit disrepair, it even smoky at some conditions.

TYPICAL CHARACTERISTICS CURVES

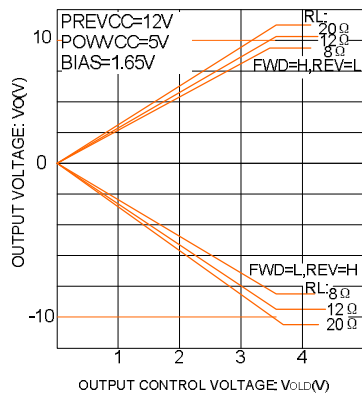
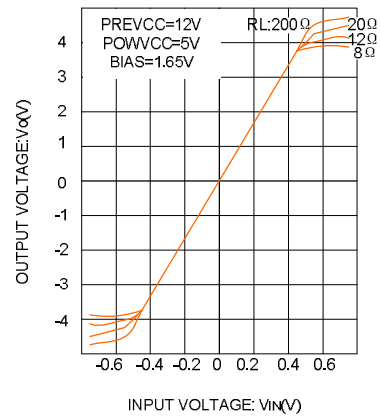
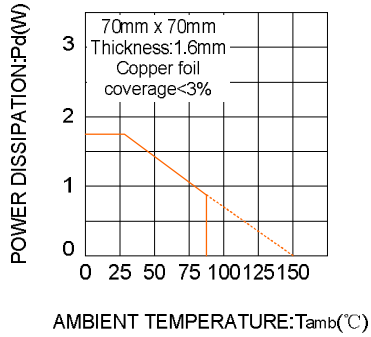

PACKAGE OUTLINE

HSOP-28-375-0.8

Unit: mm

