

**SINGLE PHASE BIDIRECTIONAL POWER/ENERGY METERING IC WITH INSTANTANEOUS PULSE OUTPUT**

**FEATURES**

- Performs bidirectional power and energy measurement
- Meets the IEC 521/1036 Specification requirements for Class 1 AC Watt hour meters
- Protected against ESD
- Total power consumption rating below 25mW
- Adaptable to different types of current sensors
- Operates over a wide temperature range
- Precision voltage reference on-chip

**DESCRIPTION**

The SAMES SA9602F is an enhancement of the SA9102F, as no external capacitors are required for the A/D converters. The SA9602J is an enhancement of the SA9102H.

The SAMES SA9602F and SA9602J Single Phase bidirectional Power/Energy metering integrated circuits generate a pulse rate output, the frequency of which is proportional to the power consumption. Both devices perform the active power calculation.

The method of calculation takes the power factor into account.

Energy consumption is determined by the power measurement being integrated over time.

These innovative universal single phase power/energy metering integrated circuits are ideally suited for energy calculations in applications such as residential municipal metering and factory energy metering and control.

The SA9602F and SA9602J integrated circuits are available in both 14 and 20 pin dual-in-line plastic (DIP-14/DIP-20), as well

as 20 pin small outline (SOIC-20) package types.

Note that the 20 pin SA9602J is a direct replacement for the SA9102H. The SA9602H has a higher output pulse rate than the SA9102H.

**PIN CONNECTIONS**

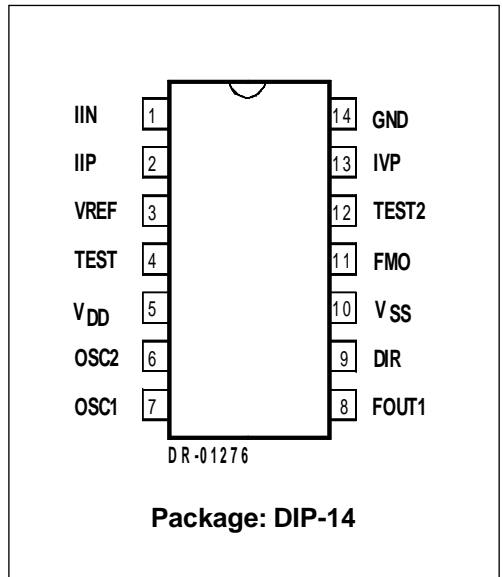

**PIN CONNECTIONS**

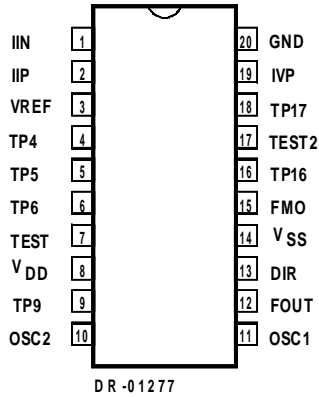

**Package: DIP-20**  
**SOIC-20**

**BLOCK DIAGRAM**

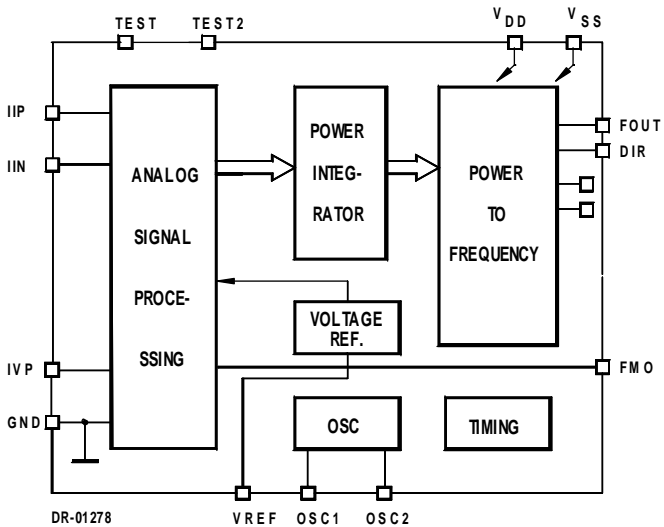

**ABSOLUTE MAXIMUM RATINGS\***

Parameter	Symbol	Min	Max	Unit
Supply Voltage	$V_{DD} - V_{SS}$	-0.3	6.0	V
Current on any pin	$I_{PIN}$	-150	+150	mA
Storage Temperature	$T_{STG}$	-40	+125	°C
Operating Temperature	$T_O$	-40	+85	°C

\* Stresses above those listed under “Absolute Maximum Ratings” may cause permanent damage to the device. This is a stress rating only. Functional operation of the device at these or any other condition above those indicated in the operational sections of this specification, is not implied. Exposure to Absolute Maximum Ratings for extended periods may affect device reliability.

**ELECTRICAL CHARACTERISTICS**

( $V_{DD} = 2.5V$ ,  $V_{SS} = -2.5V$ , over the temperature range  $-10^{\circ}C$  to  $+70^{\circ}C^{\#}$ , unless otherwise specified.)

Parameter	Symbol	Min	Typ	Max	Unit	Condition
Operating temperature range #	$T_O$	-25		+85	°C	
Supply Voltage: Positive	$V_{DD}$	2.25		2.75	V	
Supply Voltage: Negative	$V_{SS}$	-2.75		-2.25	V	
Supply Current: Positive	$I_{DD}$		5	6	mA	
Supply Current: Negative	$I_{SS}$		5	6	mA	
Current Sensor Inputs (Differential)						
Input Current Range	$I_{II}$	-25		+25	$\mu A$	Peak value
Voltage Sensor Input (Asymmetrical)						
Input Current Range	$I_{IV}$	-25		+25	$\mu A$	Peak value
Pins FOUT, DIR Output Low Voltage Output High Voltage	$V_{OL}$ $V_{OH}$	$V_{DD} - 1$		$V_{SS} + 1$	V V	$I_{OL} = 5mA$ $I_{OH} = -2mA$
Pulse Rate FOUT	$f_P$	0 0		64 180	Hz Hz	Specified linearity Min and max limits
Pulse Width tp	$t_{PP}$ $t_{pn}$		1.1 3.4		ms ms	Positive energy flow Negative energy flow

**ELECTRICAL CHARACTERISTICS (Continued)**

( $V_{DD} = 2.5V$ ,  $V_{SS} = -2.5V$ , over the temperature range  $-10^{\circ}C$  to  $+70^{\circ}C$ #, unless otherwise specified.)

Parameter	Symbol	Min	Typ	Max	Unit	Condition
Pin VREF Ref. Current Ref. Voltage	$-I_R$ $V_R$	45 1.1	50	55 1.3	$\mu A$ V	With $R = 24k\Omega$ connected to $V_{SS}$ Referred to $V_{SS}$
Oscillator	Recommended crystal: TV colour burst crystal $f = 3.5795$ MHz					

# Extended Operating Temperature Range available on request.

**PIN DESCRIPTION**

14 Pin	20 Pin	Designation	Description
14	20	GND	Ground
5	8	$V_{DD}$	Positive Supply Voltage
10	14	$V_{SS}$	Negative Supply Voltage
13	19	IVP	Analog input for Voltage
1	1	IIN	Inputs for current sensor
2	2	IIP	
3	3	VREF	Connection for current setting resistor
4	7	TEST	Test Pin. Tied to $V_{SS}$ for protection against HV transients and noise
12	18	TEST2	Test Pin. May be left unconnected or tie to $V_{SS}$
7	11	OSC1	Connections for crystal or ceramic resonator (OSC1 = Input ; OSC2 = Output)
6	10	OSC2	
8	12	FOUT	Pulse rate output
9	13	DIR	Direction indication output
11	15	FMO	Rising edge of mains frequency
	4	TP4	Test Pins (Leave unconnected)
	5	TP5	
	6	TP6	
	9	TP9	
	16	TP16	
	17	TP17	

## FUNCTIONAL DESCRIPTION

The SA9602F and SA9602J are CMOS mixed signal Analog/Digital integrated circuits, which perform power/energy calculations across a power range of 1000:1, to an overall accuracy of better than Class 1.

The integrated circuits include all the required functions for 1-phase power and energy measurement such as two oversampling A/D converters for the voltage and current sense inputs, power calculation and energy integration. Internal offsets are eliminated through the use of cancellation procedures. These devices generate pulses, the frequency of which is proportional to the power consumption. The pulse rate follows the instantaneous power consumption measured. Direction information is also provided.

A voltage zero crossover signal, relevant to the positive going half cycle, is available on pin FMO. This signal can be used to synchronise circuit breaker switching.

### 1. Power Calculation

In the Application Circuit (Figure 1), the voltage drop across the shunt will be between 0 and  $16\text{mV}_{\text{RMS}}$  (0 to 80A through a shunt resistor of  $200\mu\Omega$ ). This voltage is converted to a current of between 0 and  $16\mu\text{A}_{\text{RMS}}$ , by means of resistors  $R_1$  and  $R_2$ .

The current sense input saturates at an input current of  $\pm 25\mu\text{A}$  peak.

For the voltage sensor input, the mains voltage (230VAC) is divided down through a divider to  $14\text{V}_{\text{RMS}}$ . The current into the A/D converter input is set at  $14\mu\text{A}_{\text{RMS}}$  at nominal mains voltage, via resistor R4 ( $1\text{M}\Omega$ ).

In this configuration, with a mains voltage of 230V and a current of 80A, the output frequency of the SA9602F and SA9602J power meter chip at FOUT is 64Hz. In this case 1 pulse will correspond to an energy consumption of  $18.4\text{kW}/64\text{Hz} = 287.5\text{Ws}$ .

### 2. Analog Input Configuration

The input circuitry of the current and voltage sensor inputs are illustrated below.

These inputs are protected against electrostatic discharge through clamping diodes.

The feedback loops from the outputs of the amplifiers  $A_1$  and  $A_v$  generate virtual shorts on the signal inputs. Exact duplications of the input currents are generated for the analog signal processing circuitry.

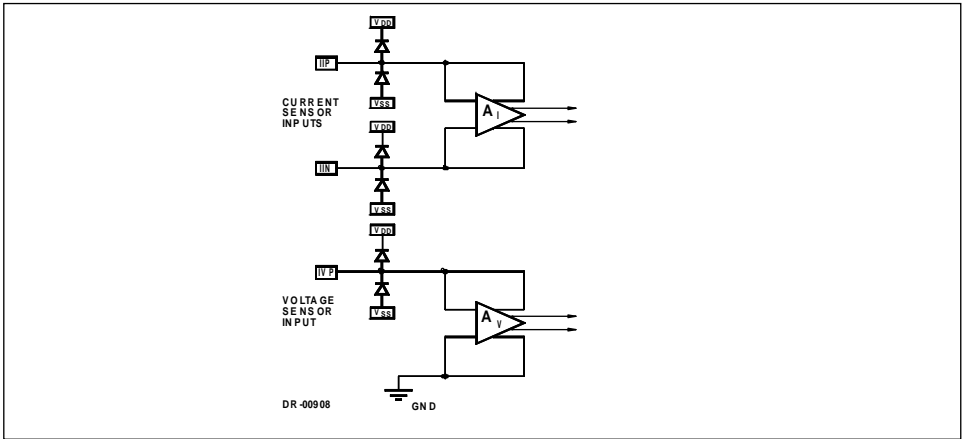

**3. Electrostatic Discharge (ESD) Protection**

The SA9602F and SA9602J integrated circuit's inputs/outputs are protected against ESD

**4. Power Consumption**

The power consumption rating of the SA9602F and SA9602J integrated circuits is less than 25mW.

**5. Pulse Output Signals**

The calculated power is divided down to a pulse rate of 64Hz, for rated conditions on FOUT for both the SA9602F and SA9602J.

The format on the pulse output signal, which provides power/energy and direction information, is the only difference between the SA9602F and SA9602J devices.

The direction of the energy flow is defined by the mark/space ratio in the SA9602F, while the pulse width defines the direction on the SA9602J.

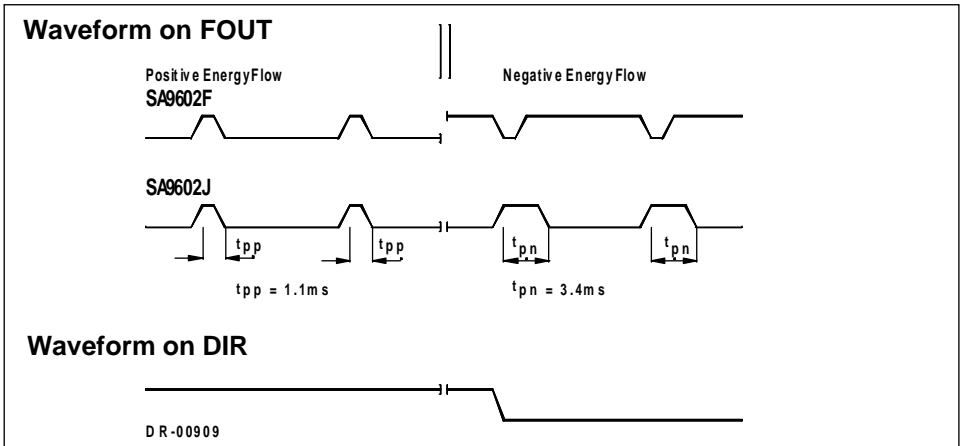

The diagram below shows the behavior of the direction indication, DIR, when energy reversal takes place. The timing period for the DIR signal to change state,  $t_{DIR}$ , will be defined by the time it takes for the integrator to count down from its value at the time of energy reversal. This is determined by the energy consumption rate.

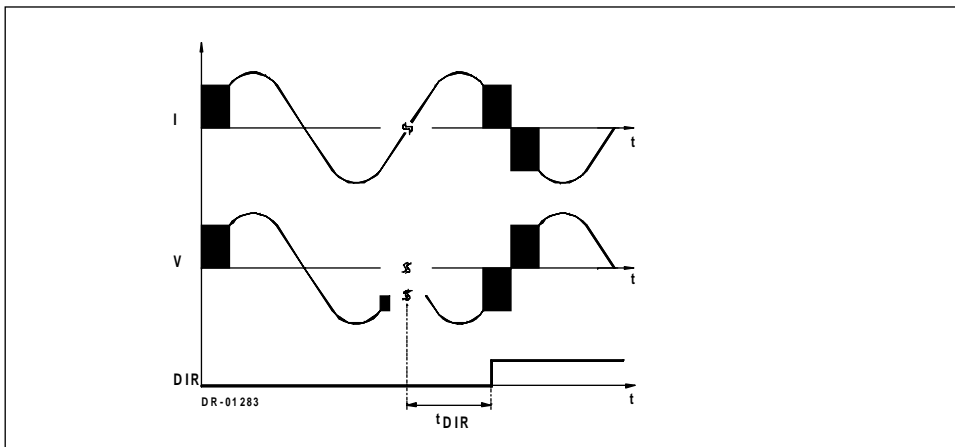

The square wave signal on FMO indicates the polarity of the mains voltage.

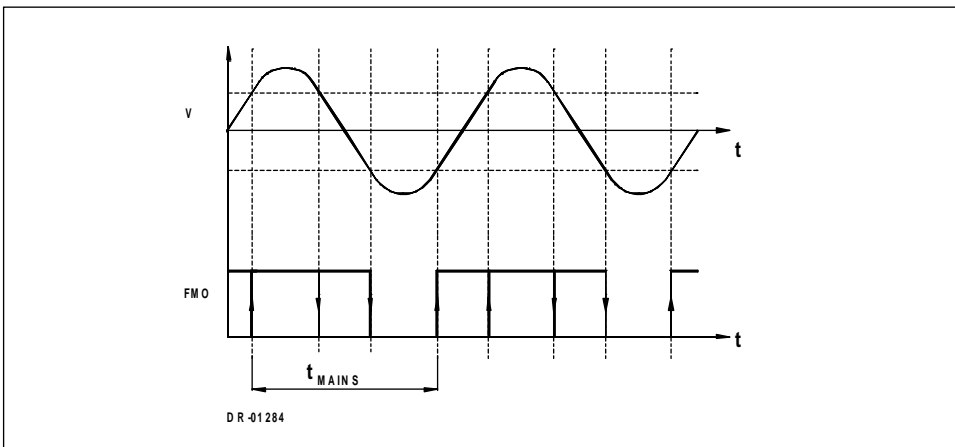

Due to comparator offsets, the FMO low to high transition can occur within a range as shown above. The time between successive low to high transitions will be equal to the mains voltage period.

## TYPICAL APPLICATIONS

In the Application Circuits (Figures 1 and 2), the components required for power metering applications, are shown.

In Figure 1, a shunt resistor is used for current sensing. In this application, the circuitry requires a +2.5V, 0V, -2.5V DC supply.

In the case of Figure 2, when using a current transformer for current sensing, a +5V, 0V DC supply is sufficient.

The most important external components for the SA9602F and SA9602J integrated circuits are:

$R_2$ ,  $R_1$  and RSH are the resistors defining the current level into the current sense input. The values should be selected for an input current of  $16\mu A_{RMS}$  into the SA9602F and SA9602J, at maximum line current.

Values for RSH of less than  $200\mu\Omega$  should be avoided.

$$R_1 = R_2 = (I_L / 16\mu A_{RMS}) * R_{SH} / 2$$

Where  $I_L$  = Line current  
RSH = Shunt resistor/termination resistor

$R_3$ ,  $R_6$  and  $R_4$  set the current for the voltage sense input. The values should be selected so that the input current into the voltage sense input (virtual ground) is set to  $14\mu A_{RMS}$ .

$R_7$  defines all on-chip bias and reference currents. With  $R_7 = 24k\Omega$ , optimum conditions are set.  $R_7$  may be varied within  $\pm 10\%$  for calibration purposes. Any change to  $R_7$  will affect the output quadratically (i.e.:  $R_7 = +5\%$ ,  $f_p = +10\%$ ).

The formula for calculating the output frequency is given below:

$$f = 11.16 * FOUTX * \frac{FOSC}{3.58MHz} * \frac{I_1 \cdot I_V}{I_R^2}$$

Where FOUTX = Normal rated frequency (64Hz)

FOSC = Oscillator frequency (2MHz ..... 4MHz)

$I_1$  = Input current for current input ( $16\mu A_{RMS}$  at rated)

$I_V$  = Input current for voltage input ( $14\mu A_{RMS}$  at rated)

$I_R$  = Reference current (typically  $50\mu A$ )

XTAL is a colour burst TV crystal ( $f = 3.5795$  MHz) for the oscillator. The oscillator frequency is divided down to 1.7897 MHz on-chip, to supply the digital circuitry and the A/D converters.





Figure 1: Application Circuit using a Shunt Resistor for Current Sensing.

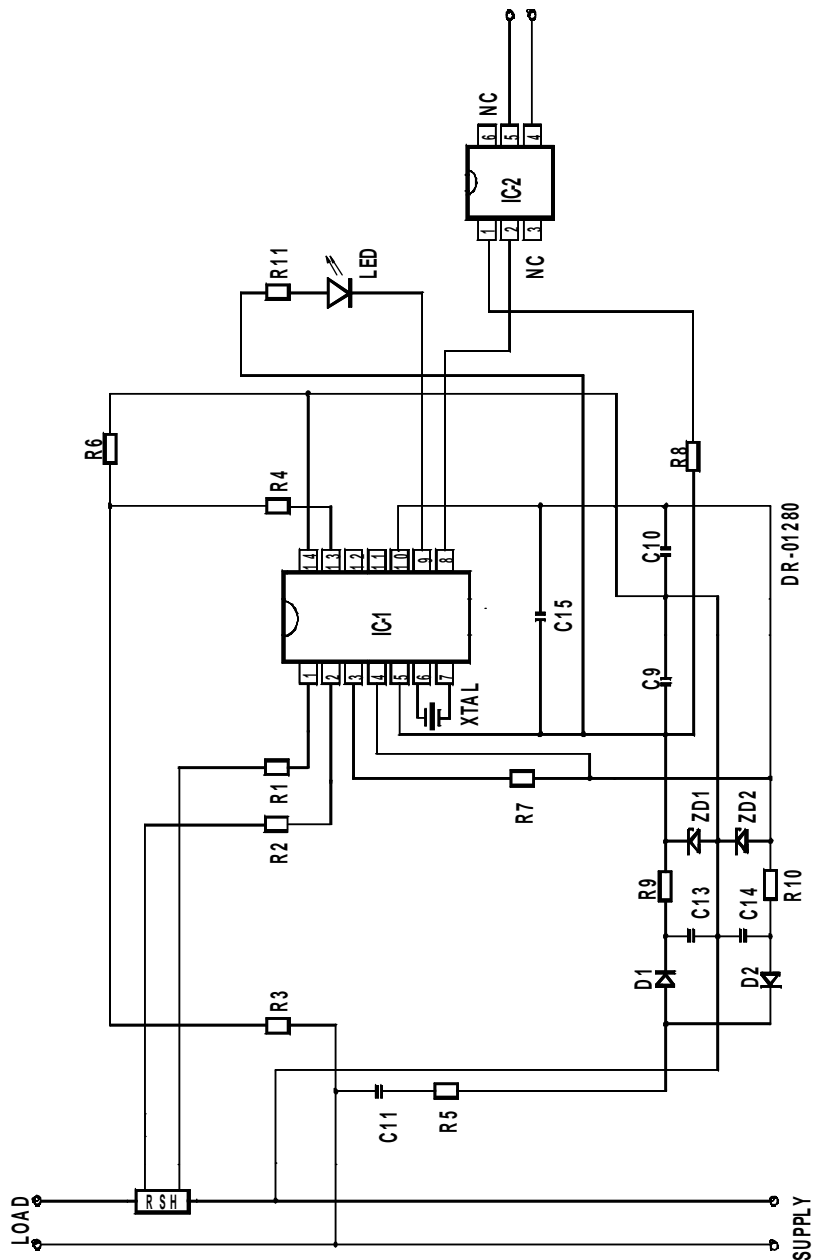

## Parts List for Application Circuit: Figure 1

Item	Symbol	Description	Detail
1	IC-1	SA9602F or SA9602J	DIP-14
2	IC-2	Optocoupler 4N35	DIP-6
3	D1	Diode, Silicon, 1N4148	
4	D2	Diode, Silicon, 1N4148	
5	ZD1	Diode, Zener, 2.4V, 200mW	
6	ZD2	Diode, Zener, 2.4V, 200mW	
7	XTAL	Crystal, 3.5795MHz	Colour burst TV
8	R1	Resistor, 1% metal	Note 1
9	R2	Resistor, 1% metal	Note 1
10	R3	Resistor, 390k, (230VAC) 1%, metal	
11	R4	Resistor, 1M, 1/4W, 1%, metal	
12	R5	Resistor, 470Ω, 2W, 5%, carbon	
13	R6	Resistor, 24k, 1/4W, 1%, metal	
14	R7	Resistor, 24k, 1/4W, 1%, metal	
15	R8	Resistor, 680Ω, 1/4W, 1%	
16	R9	Resistor, 680Ω, 1/4W, 1%	
17	R10	Resistor, 680Ω, 1/4W, 1%	
18	R11	Resistor, 2.2K, 1/4W, 1%	
19	C9	Capacitor, 100nF	
20	C10	Capacitor, 100nF	
21	C11	Capacitor, 0.47μF, 250VAC, polyester	
22	C13	Capacitor, 100μF	
23	C14	Capacitor, 100μF	
24	C15	Capacitor, 820nF	Note 2
25	RSH	Shunt Resistor	Note 3
26	LED	Light Emitting Diode	

Note 1: Resistor (R1 and R2) values are dependant upon the selected value of RSH.

Note 2: Capacitor (C15) to be positioned as close to Supply Pins ( $V_{DD}$  &  $V_{SS}$ ) of IC-1 as possible.

Note 3: See TYPICAL APPLICATIONS when selecting the value of RSH.



Figure 2: Application Circuit using a Current Transformer for Current Sensing.

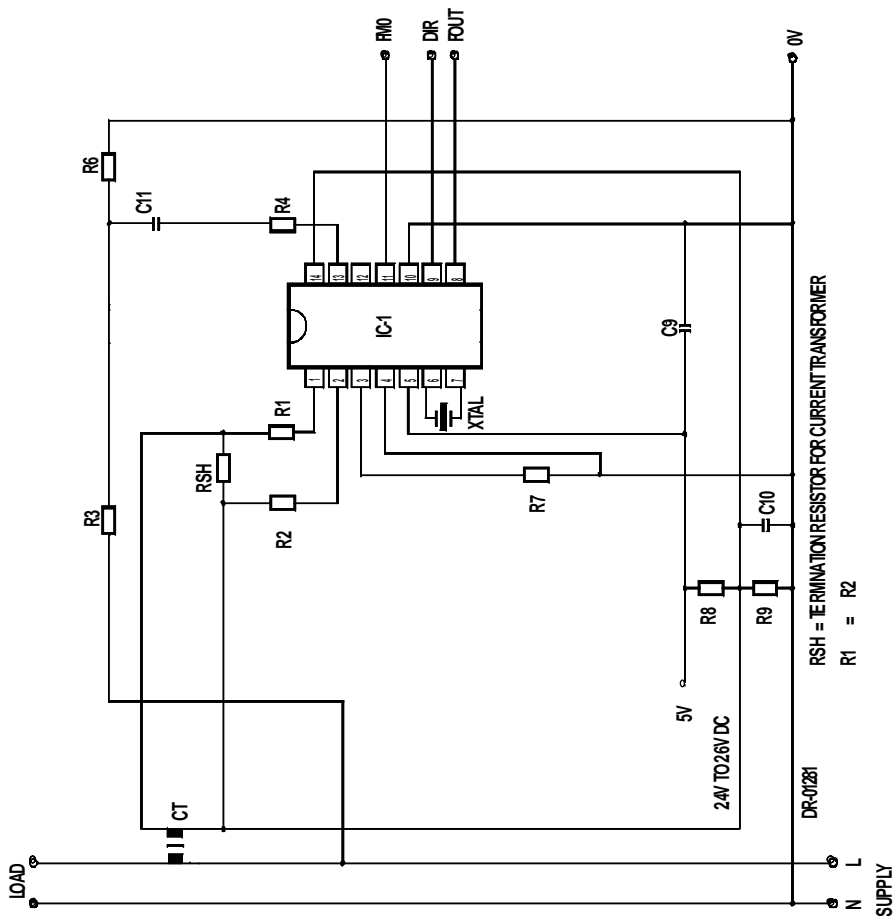

## Parts List for Application Circuit: Figure 2

Item	Symbol	Description	Detail
1	IC-1	SA9602F and SA9602J	DIP-14
2	XTAL	Crystal, 3.5795MHz	Colour burst TV
3	RSH	Resistor	Note 1
4	R1	Resistor, 1%, metal	Note 2
5	R2	Resistor, 1%, metal	Note 2
6	R3	Resistor, 390k, (230VAC), 1%, metal	
7	R4	Resistor, 1M, 1/4W, 1%, metal	
8	R6	Resistor, 24k, 1/4W, metal	
9	R7	Resistor, 24k, 1/4W, 1%, metal	
10	R8	Resistor, 2.2k, 1/4W, 1%, metal	
11	R9	Resistor, 2.2k, 1/4W, 1%, metal	
12	C9	Capacitor, 820nF	Note 3
13	C10	Capacitor, 100nF	
14	C11	Capacitor	Note 4
15	CT	Current transformer	

Note 1: See TYPICAL APPLICATIONS when selecting the value of RSH.

Note 2: Resistor (R1 and R2) values are dependant upon the selected value of RSH.

Note 3: Capacitor (C9) to be positioned as close to Supply Pins ( $V_{DD}$  &  $V_{SS}$ ) of IC-1, as possible.

Note 4: Capacitor (C11) selected to minimize phase error introduced by current transformer (typically 1.5 $\mu$ F).

## ORDERING INFORMATION

Part Number	Package
SA9602FPA	DIP-14
SA9602FPA	DIP-20
SA9602FSA	SOIC-20
SA9602JPA	DIP-14
SA9602JPA	DIP-20
SA9602JSA	SOIC-20

Note: When ordering, the Package Option **must** be specified along with the Part Number.



Notes:

**Disclaimer:** The information contained in this document is confidential and proprietary to South African Micro-Electronic Systems (Pty) Ltd ("SAMES") and may not be copied or disclosed to a third party, in whole or in part, without the express written consent of SAMES. The information contained herein is current as of the date of publication; however, delivery of this document shall not under any circumstances create any implication that the information contained herein is correct as of any time subsequent to such date. SAMES does not undertake to inform any recipient of this document of any changes in the information contained herein, and SAMES expressly reserves the right to make changes in such information, without notification, even if such changes would render information contained herein inaccurate or incomplete. SAMES makes no representation or warranty that any circuit designed by reference to the information contained herein, will function without errors and as intended by the designer.

Any sales or technical questions may be posted to our e-mail address below:  
[energy@sames.co.za](mailto:energy@sames.co.za)

For the latest updates on datasheets, please visit our web site:  
<http://www.sames.co.za>

**South African Micro-Electronic Systems (Pty) Ltd**

P O Box 15888,  
Lynn East, 0039  
Republic of South Africa,

33 Eland Street,  
Koedoespoort Industrial Area,  
Pretoria,  
Republic of South Africa

Tel: 012 333-6021  
Fax: 012 333-8071

Tel: Int +27 12 333-6021  
Fax: Int +27 12 333-8071

