

## RF AMPLIFIER FOR DIGITAL SERVO SYSTEM

### DESCRIPTION

SA9618A can be used for ALPC and signal conversion between CD optical pickup and decoding chip.

This IC incorporates an interconnection to general CD optical pickup photodiode, bias voltage VREF generation circuit, RF amplifier and ALPC circuit. (This IC is adaptive for CD-A/V, CD-R, CD-RW, CD-ROM).

### FEATURES

- \* RF amplitude automatic adjustment circuit .(It is adaptive for CD-A/V, CD-R, CD-RW, CD-ROM)
- \* Low power consumption.(35mW ~ 3.5V)
- \* ALPC circuit
- \* Operating voltage range:2.8V – 7.0V

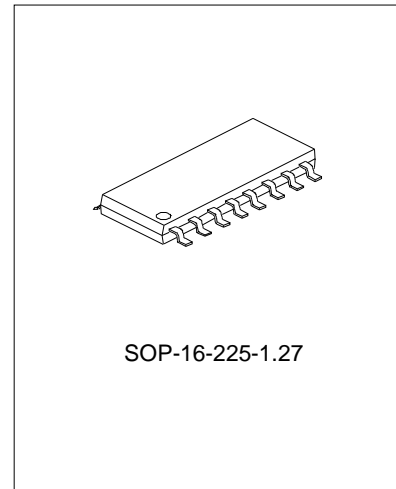

### APPLICATIONS

- \* CD Players
- \* VCD Players

### ORDERING INFORMATION

Device	Package
SA9618A	SOP-16-225-1.27

### BLOCK DIAGRAM

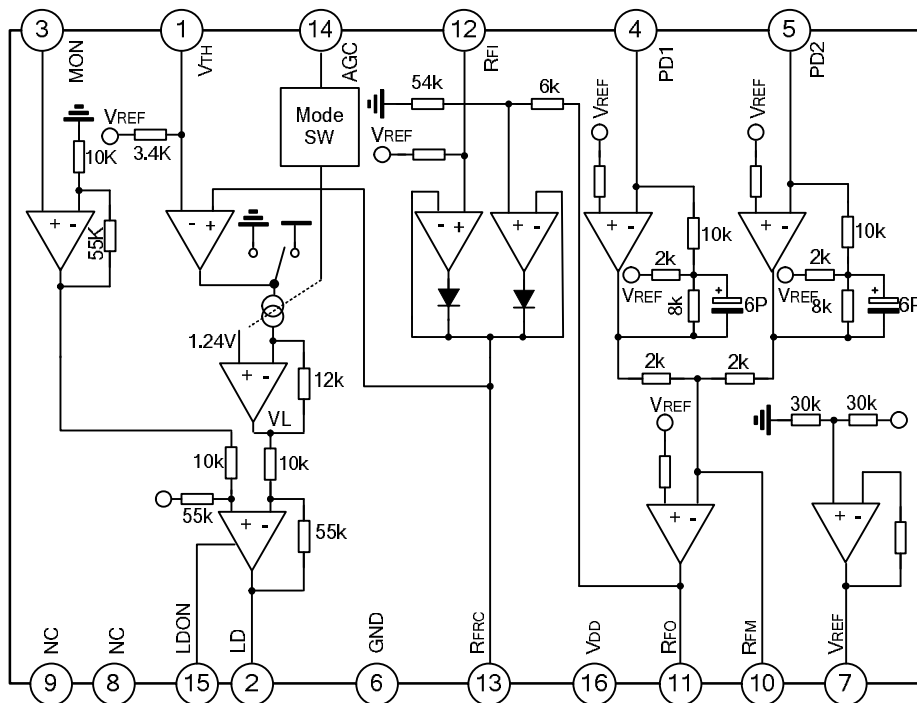

**ABSOLUTE MAXIMUM RATINGS** (T<sub>amb</sub>=25°C)

Characteristics	Symbol	Rating	Unit
Supply Voltage	VDD	-0.5 ~ +12	V
Operating Temperature	Topr	-20 ~ +75	°C
Power Dissipation	PD	370	mW

**DC ELECTRICAL CHARACTERISTICS**

Characteristics	Symbol	Test Condition	Min.	Typ.	Max.	Unit
Supply voltage	VDD		2.8	5.0	7.0	V
Bias Output Of Photoelectric Signal	VREF		--	2.5	--	V
Current Consumption	IDD	VDD=5V	--	12	--	mA

**AC ELECTRICAL CHARACTERISTICS**

Characteristics	Symbol	Test Conditions	Min.	Typ.	Max.	Unit
Diode Control Input	MON		--	0.17	--	V
Photoelectric Input 1(A+C)	PD1	DA11	0	--	0.60	V
		KSS213	0	--	0.15	V
Photoelectric Input 2(B+D)	PD2	DA11	0	--	0.60	V
		KSS213	0	--	0.15	V
Gain Of RF Signal	GAIN	1MHZ, 300mVpp	--	15	--	dB

Note 1: The resistance between Pin RFM and Pin RFO is 5.5K.

**PIN CONFIGURATION**

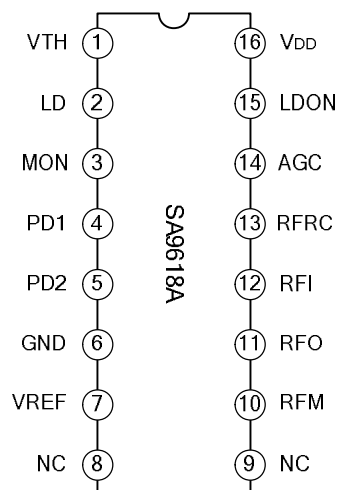

**PIN DESCRIPTION**

Pin No.	Symbol	Description
1	VTH	Reference level variable pin for RF level control.
2	LD	APC circuit output pin.
3	MON	Diode control input pin.
4	PD1	Photoelectric input1 (A+C) pin.
5	PD2	Photoelectric input2 (B+D) pin.
6	GND	GND
7	VREF	Bias output pin of OEIC.
8	NC	RF level control ON/OFF switching pin
9	NC	Gain select pin for RF signal.
10	RFM	RF level control output pin
11	RFO	RF amplifier inverted side output pin. RF amplifier gain is determined by the resistor connected between RFO pin and RFM pin.
12	RFI	RF amplifier input pin.
13	RFRC	External time-constant pin for RF level control.
14	AGC	The automatic switching pin for optical power.
15	LDON	ALPC circuit ON/OFF switching pin.
16	VDD	VDD pin.

NOTE: LDON pin is low active in SA9618A, but it must be connected to an external resistor of 150k $\Omega$ .

**FUNCTION DESCRIPTIONS**

SA9618A can be divided into three parts: Reference voltage generation circuit; RF signal processing circuit incorporating two RF Amplifiers and an RF adder; Automatic switching APC circuit incorporating optical power switching circuit, RF demodulation circuit and automatic optical power control circuit.

Reference voltage is half of VDD. It is not only the common level for amplifier in circuit, but also the bias voltage of OEIC.

The feedback resistor of each RF Amplifier is 58k $\Omega$ . And the gain of RF amplifier is the ratio of the 58k $\Omega$  equivalent resistance and external resistor connected between PD1 pin and PD2 pin. When the resistance value is 33k, the gain of RF Amplifier is 1.76.

The output of each RF Amplifier is added by RF adder. The gain of RF adder can be adjusted by varying the resistor connected between RFM pin and RFO pin. When the resistance value is 5.5k, the gain of RF summing amplifier is 2.75.

The output of Peak value of RF demodulation circuit comes from the output of RF adder. The DC voltage formed by external RC filter of RFRC pin, and it is related to the level of input of PD1 pin and PD2 pin. The DC voltage will increase as the level of the input becomes higher.

Optical Power switching circuit is controlled by AGC pin. It has three modes: connected to GND, open, connected to supply voltage. The optical power can be adjusted by varying the voltage of VL. There are five VL values, and it is as follows.

AGC	The level of input	Value of VL	Strength of optical power
VCC	*	1.25V	middle
OPEN	large RFRC>VTH	0.9V	weaker
OPEN	small RFRC>VTH	1.6V	stronger
GND	large RFRC>VTH	0.7	weakest
GND	small RFRC>VTH	1.8	strongest

Pin LDON controls APC circuit. In SA9618A, APC is set to ON by connecting the LDON pin to GND; and set to OFF by connecting it to VDD, and SA9618A should be connected to an external resistance of 150kΩ between LDON pin and external MCU.

### TEST CIRCUITS

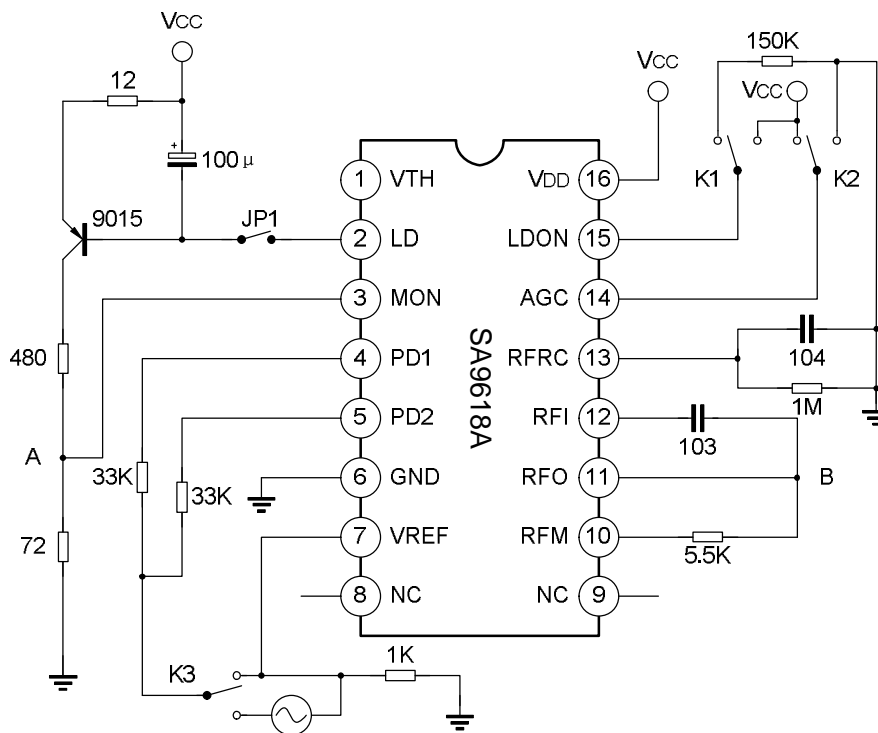

**TYPICAL APPLICATION CIRCUIT**

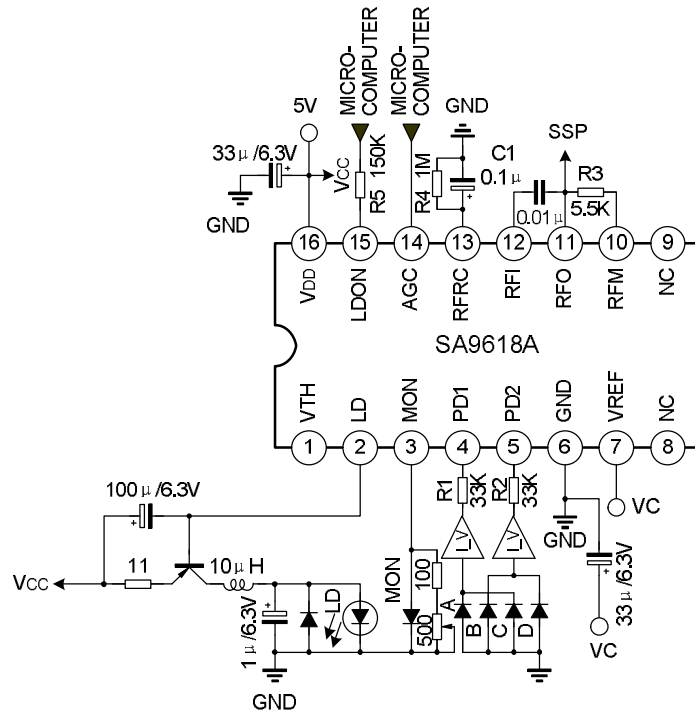

**PACKAGE OUTLINE**

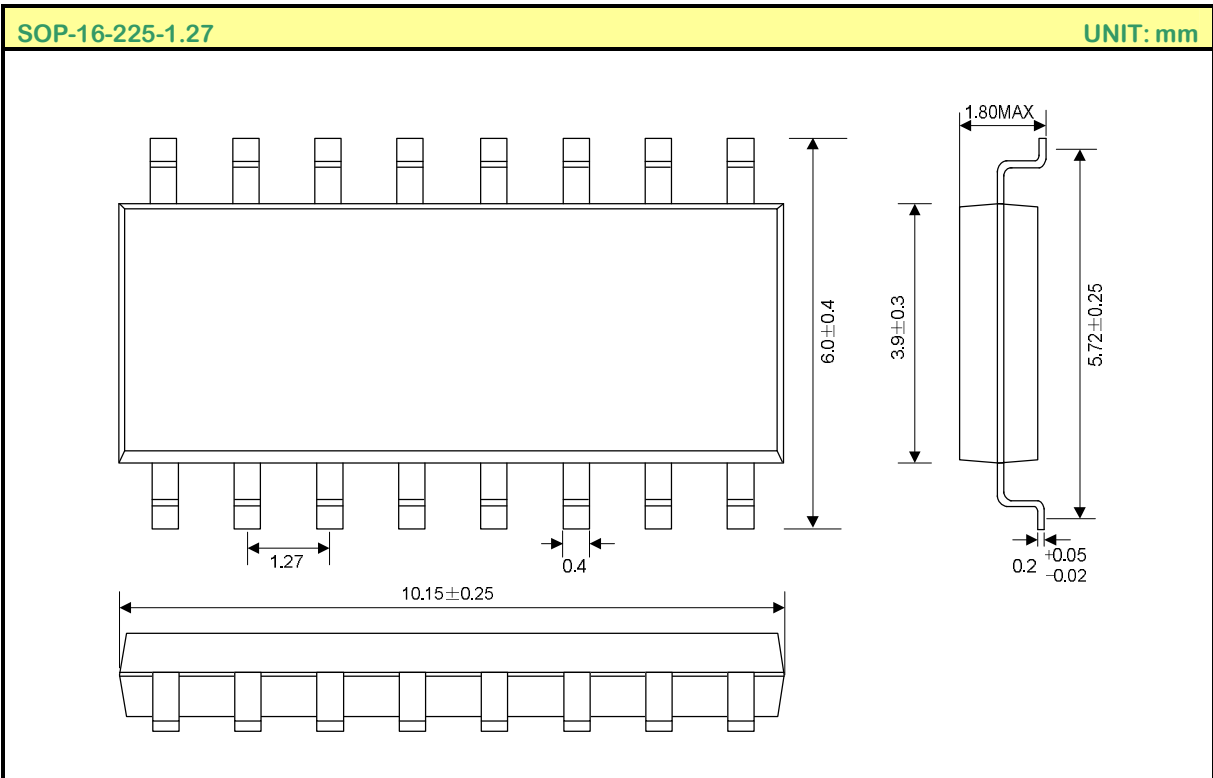

## Attach

## Revision History

Data	REV	Description	Page
2006.01.23	1.0	Original	
2006.07.14	1.1	Modify the "TYPICAL APPLICATION CIRCUIT"	