

SIEMENS

SIEMENS AKTIENGESELLSCHAFT

T-49-19-05

8-Bit Single Chip Microcontroller**SAB 8052A/8032A****Preliminary**

SAB 8052A-P(N) Microcontroller with factory-maskprogrammabel ROM
SAB 8032A-P(N) Microcontroller for external ROM

- 8 K × 8 ROM (SAB 8052A only)
- 256 × 8 RAM
- Four 8-bit ports, 32 I/O lines
- Three 16-bit timer/event counters
- High-performance full-duplex serial channel with flexible transmit/receive baud rate capability
- External memory expandable up to 128 Kbytes
- Boolean processor
- Most instructions execute in 1 μ s
- Multiply and divide in 4 μ s
- Six interrupt vectors, two priority levels
- RAM power-down supply
- P-DIP-40 and PL-CC-44 package
- Full backward compatibility with SAB 8051/8031

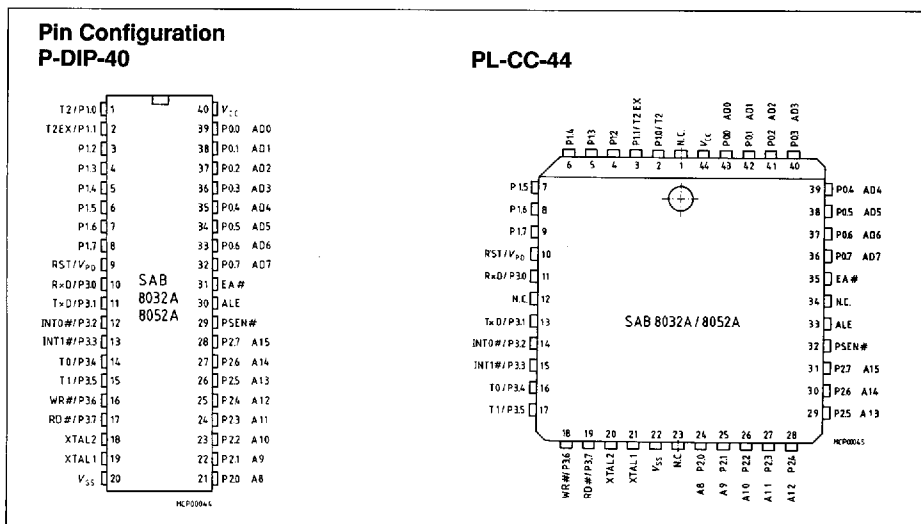

The SAB 8052A/8032A is a standalone, high-performance single-chip microcontroller fabricated in + 5 V advanced N-channel, silicon gate Siemens MYMOS technology, packaged in a 40-pin DIP or 44-pin plastic leaded chip carrier (PL-CC-44) package. It is backwardly compatible with the SAB 8051A/8031A. It provides the hardware features,

T-49-19-05

architectural enhancements, and instructions that are necessary to make it a powerful and cost-effective controller for applications requiring up to 64 Kbytes of program memory and/or up to 64 Kbytes of data memory.

The SAB 8052A contains a non-volatile 8 K × 8 read-only program memory; a volatile 256 × 8 read/write data memory; 32 I/O lines; three 16-bit timer/ counters; a six-source, two-priority-level, nested interrupt structure; a serial I/O port for either multiprocessor communications, I/O expansion, or full-duplex UART; as well as on-chip oscillator and clock circuits. The SAB 8032A is identical with the SAB 8052A, except that it lacks the program memory.

For systems that require extra capability, the SAB 8052A can be expanded using standard TTL compatible memories and the byte-oriented SAB 8080 and SAB 8085 peripherals.

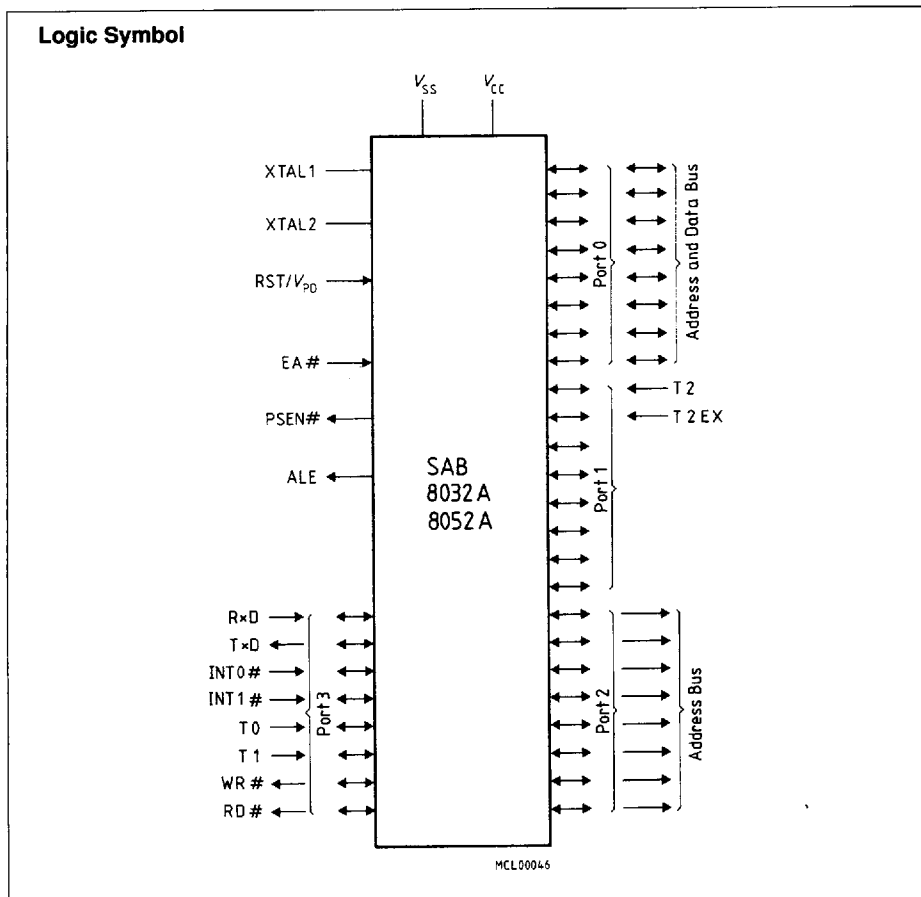

T-49-19-05

Pin Definitions and Functions

Symbol	Pin		Input (I) Output (O)	Function
	DIP-40	PL-CC-44		
P1.0-P1.7	1-8	2-9	I/O	Port 1 is an 8-bit quasi-bidirectional I/O port. It is used for the low-order address byte during program verification. Port 1 can sink/source four LS TTL loads. Port 1 also contains the timer 2 pins as a secondary function. The output latch corresponding to a secondary function must be programmed to a one (1) for that function to operate. The secondary functions are assigned to the pins of port 1, as follows: <ul style="list-style-type: none"> - T2 (P1.0). Input to counter 2. - T2 EX (P1.1). Capture/Reload trigger of timer 2.
RST/V _{PD}	9	10	I	A high level on this pin resets the SAB 8052A. A small internal pulldown resistor permits power-on reset using only a capacitor connected to V _{CC} . If V _{PD} is held within its spec while V _{CC} drops below spec, V _{PD} will provide standby power to the RAM. When V _{PD} is low, the RAM's current is drawn from V _{CC} .
P3.0-P3.7	10-17	11, 13-19	I/O	Port 3 is an 8-bit quasi-bidirectional I/O port. It also contains the interrupt, timer, serial port and \overline{RD} and \overline{WR} pins that are used by various options. The output latch corresponding to a secondary function must be programmed to a one (1) for that function to operate. Port 3 can sink/source four LS TTL loads. The secondary functions are assigned to the pins of Port 3, as follows: <ul style="list-style-type: none"> - RxD/data (P3.0). Serial port's receiver data input (asynchronous) or data input/output (synchronous). - TxD/clock (P3.1). Serial port's transmitter data output (asynchronous) or clock output (synchronous). - INT0 (P3.2). Interrupt 0 input or gate control input for counter 0. - INT1 (P3.3). Interrupt 1 input or gate control input for counter 1. - T0 (P3.4). Input to counter 0. - T1 (P3.5). Input to counter 1. - \overline{WR} (P3.6). The write control signal latches the data byte from port 0 into the external data memory. - \overline{RD} (P3.7). The read control signal enables external data memory to port 0.
XTAL 1 XTAL 2	19 18	21 20	I	XTAL 1 input to the oscillator's high gain amplifier. Required when a crystal is used. Connect to V _{SS} when external source is used on XTAL 2. XTAL 2 output from the oscillator's amplifier. Input to the internal timing circuitry. A crystal or external source can be used.
P2.0-P2.7	21-28	24-31	I/O	Port 2 is an 8-bit quasi-bidirectional I/O port. It also emits the high-order address byte when accessing external memory. It is used for the high-order address and the control signals during program verification. Port 2 can sink/source four LS TTL loads.

T-49-19-05

Pin Definitions and Functions (cont'd)

Symbol	Pin		Input (I) Output (O)	Function
	DIP-40	PL-CC-44		
PSEN	29	32	O	The programm store enable output is a control signal that enables the external program memory to the bus during external fetch operations. It is activated every six oscillator periods, except during external data memory accesses. Remains high during internal program execution.
ALE	30	33	O	Provides address latch enable output used for latching the address into external memory during normal operation. It is activated every six oscillator periods except during an external data memory access.
\overline{EA}	31	35	I	When held at a TTL high level, the SAB 8052A executes instructions from the internal ROM when the PC is less than 8192. When held at a TTL low level, the SAB 8052A fetches all instructions from external program memory. For the SAB 8032A this pin must be tied low.
P0.0-P0.7	39-32	43-36	I/O	Port 0 is an 8-bit open drain bidirectional I/O port. It is also the multiplexed low-order address and data bus when using external memory. It is used for data output during program verification. Port 0 can sink/source eight LS TTL loads.
Vcc	40	44	-	+ 5 V power supply during operation and program verification.
Vss	20	22	-	Circuit ground potential
NC	-	1, 12 23, 34	-	No connection

T-49-19-05

Block Diagram

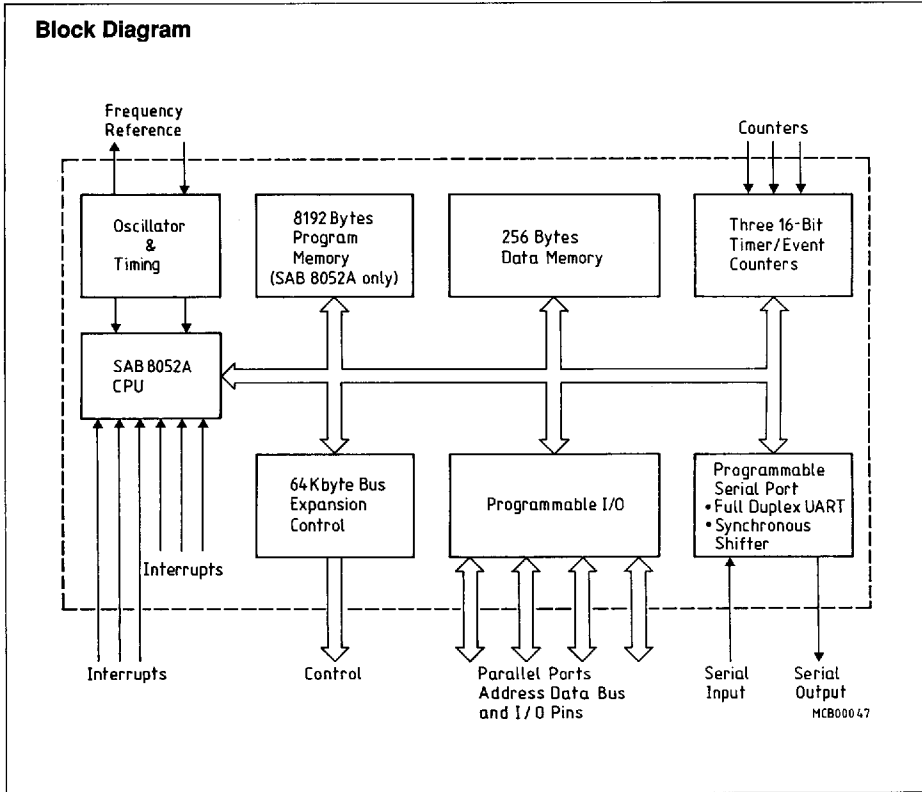

T-49-19-05

Instruction Set Summary

Mnemonic	Description	Byte	Cycle
----------	-------------	------	-------

Arithmetic operations

ADD	A,Rn	Add register to accumulator	1	1
ADD	A,direct	Add direct byte to accumulator	2	1
ADD	A,@Ri	Add indirect RAM to accumulator	1	1
ADD	A,#data	Add immediate data to accumulator	2	1
ADDC	A,Rn	Add register to accumulator with carry flag	1	1
ADDC	A,direct	Add direct byte to A with carry flag	2	1
ADDC	A,@Ri	Add indirect RAM to A with carry flag	1	1
ADDC	A,#data	Add immediate data to A with carry flag	2	1
SUBB	A,Rn	Subtract register from A with borrow	1	1
SUBB	A,direct	Subtract direct byte from A with borrow	2	1
SUBB	A,@Ri	Subtract indirect RAM from A with borrow	1	1
SUBB	A,#data	Subtract immediate data from A with borrow	2	1
INC	A	Increment accumulator	1	1
INC	Rn	Increment register	1	1
INC	direct	Increment direct byte	2	1
INC	@Ri	Increment indirect RAM	1	1
DEC	A	Decrement accumulator	1	1
DEC	Rn	Decrement register	1	1
DEC	direct	Decrement direct byte	2	1
DEC	@Ri	Decrement indirect RAM	1	1
INC	DPTR	Increment data pointer	1	2
MUL	AB	Multiply A and B	1	4
DIV	AB	Divide A by B	1	4
DA	A	Decimal adjust accumulator	1	1

T-49-19-05

Instruction Set Summary (cont'd)

Mnemonic		Description	Byte	Cycle
Logical operations				
ANL	A,Rn	AND register to accumulator	1	1
ANL	A,direct	AND direct byte to accumulator	2	1
ANL	A,@Ri	AND indirect RAM to accumulator	1	1
ANL	A,#data	AND immediate data to accumulator	2	1
ANL	direct,A	AND accumulator to direct byte	2	1
ANL	direct,#data	AND immediate data to direct byte	3	2
ORL	A,Rn	OR register to accumulator	1	1
ORL	A,direct	OR direct byte to accumulator	2	1
ORL	A,@Ri	OR indirect RAM to accumulator	1	1
ORL	A,#data	OR immediate data to accumulator	2	1
ORL	direct,A	OR accumulator to direct byte	2	1
ORL	direct,#data	OR immediate data to direct byte	3	2
XRL	A,Rn	Exclusive OR register to accumulator	1	1
XRL	A,direct	Exclusive OR direct byte to accumulator	2	1
XRL	A,@Ri	Exclusive OR indirect RAM to accumulator	1	1
XRL	A,#data	Exclusive OR immediate data to accumulator	2	1
XRL	direct,A	Exclusive OR accumulator to direct byte	2	1
XRL	direct,#data	Exclusive OR immediate data to direct byte	3	2
CLR	A	Clear accumulator	1	1
CPL	A	Complement accumulator	1	1
RL	A	Rotate accumulator left	1	1
RLC	A	Rotate A left through carry flag	1	1
RR	A	Rotate accumulator right	1	1
RRC	A	Rotate A right through carry flag	1	1
SWAP	A	Swap nibbles within the accumulator	1	1

T-49-19-05

Instruction Set Summary (cont'd)

Mnemonic	Description	Byte	Cycle
Data transfer			
MOV	A,Rn	Move register to accumulator	1 1
MOV	A,direct*)	Move direct byte to accumulator	2 1
MOV	A,@Ri	Move indirect RAM to accumulator	1 1
MOV	A,#data	Move immediate data to accumulator	2 1
MOV	Rn,A	Move accumulator to register	1 1
MOV	Rn,direct	Move direct byte to register	2 2
MOV	Rn,#data	Move immediate data to register	2 1
MOV	direct, A	Move accumulator to direct byte	2 1
MOV	direct,Rn	Move register to direct byte	2 2
MOV	direct,direct	Move direct byte to direct byte	3 2
MOV	direct,@R	Move indirect RAM to direct byte	2 2
MOV	direct,#data	Move immediate data to direct byte	3 2
MOV	@Ri,A	Move accumulator to indirect RAM	1 1
MOV	@Ri,direct	Move direct byte to indirect RAM	2 2
MOV	@Ri,#data	Move immediate data to indirect RAM	2 1
MOV	DPTR,#data 16	Load data pointer with a 16-bit constant	3 2
MOVC	A,@A+DPTR	Move code byte relative to DPTR to accumulator	1 2
MOVC	A,@A+PC	Move code byte relative to PC to accumulator	1 2
MOVX	A,@Ri	Move external RAM (8-bit addr.) to accumulator	1 2
MOVX	A,@DPTR	Move external RAM (16-bit addr.) to accumulator	1 2
MOVX	@Ri,A	Move A to external RAM (8-bit addr.)	1 2
MOVX	@DPTR,A	Move A to external RAM (16-bit addr.)	1 2
PUSH	direct	Push direct byte onto stack	2 2
POP	direct	Pop direct byte from stack	2 2
XCH	A,Rn	Exchange register with accumulator	1 1
XCH	A,direct	Exchange direct byte with accumulator	2 1
XCH	A,@Ri	Exchange indirect RAM with accumulator	1 1
XCHD	A,@Ri	Exchange low-order digit indirect RAM with A	1 1

*) MOV A,AAC is not a valid instruction

T-49-19-05

Instruction Set Summary (cont'd)

Mnemonic	Description	Byte	Cycle
----------	-------------	------	-------

Boolean variable manipulation

CLR	C	Clear carry flag	1	1
CLR	bit	Clear direct bit	2	1
SETB	C	Set carry flag	1	1
SETB	bit	Set direct bit	2	1
CPL	C	Complement carry flag	1	1
CPL	bit	Complement direct bit	2	1
ANL	C,bit	AND direct bit to carry flag	2	2
ANL	C,/bit	AND complement of direct bit to carry	2	2
ORL	C,bit	OR direct bit to carry flag	2	2
ORL	C,/bit	OR complement of direct bit to carry	2	2
MOV	C,bit	Move direct bit to carry flag	2	1
MOV	bit,C	Move carry flag to direct bit	2	2

SIEMENS AKTIENGESELLSCHAFT

T-49-19-05

Instruction Set Summary (cont'd)

Mnemonic		Description	Byte	Cycle
Program and machine control				
ACALL	addr 11	Absolute subroutine call	2	2
LCALL	addr 16	Long subroutine call	3	2
RET		Return from subroutine	1	2
RETI		Return from interrupt	1	2
AJMP	addr 11	Absolute jump	2	2
LJMP	addr 16	Long jump	3	2
SJMP	rel	Short jump (relative addr.)	2	2
JMP	@A+DPTR	Jump indirect relative to the DPTR	1	2
JZ	rel	Jump if accumulator is zero	2	2
JNZ	rel	Jump if accumulator is not zero	2	2
JC	rel	Jump if carry flag is set	2	2
JNC	rel	Jump if carry flag is not set	2	2
JB	bit,rel	Jump if direct bit is set	3	2
JNB	bit,rel	Jump if direct bit is not set	3	2
JBC	bit,rel	Jump if direct bit is set and clear bit	3	2
CJNE	A,direct,rel	Compare direct byte to A and jump if not equal	3	2
CJNE	A,#data,rel	Comp. immed. to A and jump if not equal	3	2
CJNE	Rn,#data,rel	Comp. immed. to reg. and jump if not equal	3	2
CJNE	@Ri,#data,rel	Comp. immed. to ind. and jump if not equal	3	2
DJNZ	Rn,rel	Decrement register and jump if not zero	2	2
DJNZ	direct,rel	Decrement direct and jump if not zero	3	2
NOP		No operation	1	1

Notes on data addressing modes:

- Rn - Working register R0 - R7
- direct - 128 internal RAM locations, any I/O port, control or status register
- @Ri - Indirect internal or external RAM location addressed by register R0 or R1
- #data - 8-bit constant included in instruction
- #data 16 - 16-bit constant included as bytes 2 and 3 of instruction
- bit - 128 software flags, any I/O pin, control or status bit
- A - Accumulator

Notes on program addressing modes

- addr 16 - Destination address for LCALL and LJMP may be anywhere within the 64 Kbyte program memory address space.
- addr 11 - Destination address for ACALL and AJMP will be within the same 2 Kbyte page of program memory as the first byte of the following instruction.
- rel - SJMP and all conditional jumps include an 8-bit offset byte. Range is +127/-128 bytes relative to first byte of the following instruction.

All mnemonics copyrighted © Intel Corporation 1980

T-49-19-05

Instruction Op Codes in Hexadecimal Order

Hex code	Number of bytes	Mnemonic	Operands	Hex code	Number of bytes	Mnemonic	Operands
00	1	NOP		33	1	RLC	A
01	2	AJMP	<i>code addr</i>	34	2	ADDC	A,#data
02	3	LJMP	<i>code addr</i>	35	2	ADDC	A,data addr
03	1	RR	A	36	1	ADDC	A,@R0
04	1	INC	A	37	1	ADDC	A,@R1
05	2	INC	<i>data addr</i>	38	1	ADDC	A,R0
06	1	INC	@R0	39	1	ADDC	A,R1
07	1	INC	@R1	3A	1	ADDC	A,R2
08	1	INC	R0	3B	1	ADDC	A,R3
09	1	INC	R1	3C	1	ADDC	A,R4
0A	1	INC	R2	3D	1	ADDC	A,R5
0B	1	INC	R3	3E	1	ADDC	A,R7
0C	1	INC	R4	3F	1	ADDC	A,R7
0D	1	INC	R5	40	2	JC	<i>code addr</i>
0E	1	INC	R6	41	2	AJMP	<i>code addr</i>
0F	1	INC	R7	42	2	ORL	<i>data addr,A</i>
10	3	JBC	<i>bit addr,code addr</i>	43	3	ORL	<i>data addr,#data</i>
11	2	ACALL	<i>code addr</i>	44	2	ORL	A,#data
12	3	LCALL	<i>code addr</i>	45	2	ORL	A,data addr
13	1	RRC	A	46	1	ORL	A,@R0
14	1	DEC	A	47	1	ORL	A,@R1
15	2	DEC	<i>data addr</i>	48	1	ORL	A,R0
16	1	DEC	@R0	49	1	ORL	A,R1
17	1	DEC	@R1	4A	1	ORL	A,R2
18	1	DEC	R0	4B	1	ORL	A,R3
19	1	DEC	R1	4C	1	ORL	A,R4
1A	1	DEC	R2	4D	1	ORL	A,R5
1B	1	DEC	R3	4E	1	ORL	A,R6
1C	1	DEC	R4	4F	1	ORL	A,R7
1D	1	DEC	R5	50	2	JNC	<i>code addr</i>
1E	1	DEC	R6	51	2	ACALL	<i>code addr</i>
1F	1	DEC	R7	52	2	ANL	<i>data addr,A</i>
20	3	JB	<i>bit addr,code addr</i>	53	3	ANL	<i>data addr,#data</i>
21	2	AJMP	<i>code addr</i>	54	2	ANL	A,#data
22	1	RET		55	2	ANL	A,data addr
23	1	RL	A	56	1	ANL	A,@R0
24	2	ADD	A,#data	57	1	ANL	A,@R1
25	2	ADD	A, <i>data addr</i>	58	1	ANL	A,R0
26	1	ADD	A,@R0	59	1	ANL	A,R1
27	1	ADD	A,@R1	5A	1	ANL	A,R2
28	1	ADD	A,R0	5B	1	ANL	A,R3
29	1	ADD	A,R1	5C	1	ANL	A,R4
2A	1	ADD	A,R2	5D	1	ANL	A,R5
2B	1	ADD	A,R3	5E	1	ANL	A,R6
2C	1	ADD	A,R4	5F	1	ANL	A,R7
2D	1	ADD	A,R5	60	2	JZ	<i>code addr</i>
2E	1	ADD	A,R6	61	2	AJMP	<i>code addr</i>
2F	1	ADD	A,R7	62	2	XRL	<i>data addr,A</i>
30	3	JNB	<i>bit addr,code addr</i>	63	3	XRL	<i>data addr,#data</i>
31	2	ACALL	<i>code addr</i>	64	2	XRL	A,#data
32	1	RETI		65	2	XRL	A,data addr

T-49-19-05

Instruction Op Codes in Hexadecimal Order (cont'd)

Hex code	Number of bytes	Mnemonic	Operands	Hex code	Number of bytes	Mnemonic	Operands
66	1	XRL	A,@R0	99	1	SUBB	A,R1
67	1	XRL	A,@R1	9A	1	SUBB	A,R2
68	1	XRL	A,R0	9B	1	SUBB	A,R3
69	1	XRL	A,R1	9C	1	SUBB	A,R4
6A	1	XRL	A,R2	9D	1	SUBB	A,R5
6B	1	XRL	A,R3	9E	1	SUBB	A,R6
6C	1	XRL	A,R4	9F	1	SUBB	A,R7
6D	1	XRL	A,R5	A0	2	ORL	C,/bit addr
6E	1	XRL	A,R6	A1	2	AJMP	code addr
6F	1	XRL	A,R7	A2	2	MOV	C,bit addr
70	2	JNZ	code addr	A3	1	INC	DPTR
71	2	ACALL	code addr	A4	1	MUL	AB
72	2	ORL	C,bit addr	A5		reserved	
73	1	JMP	@A+DPTR	A6	2	MOV	@R0,data addr
74	2	MOV	A,#data	A7	2	MOV	@R1,data addr
75	3	MOV	data addr,#data	A8	2	MOV	R0,data addr
76	2	MOV	@R0,#data	A9	2	MOV	R1,data addr
77	2	MOV	@R1,#data	AA	2	MOV	R2,data addr
78	2	MOV	R0,#data	AB	2	MOV	R3,data addr
79	2	MOV	R1,#data	AC	2	MOV	R4,data addr
7A	2	MOV	R2,#data	AD	2	MOV	R5,data addr
7B	2	MOV	R3,#data	AE	2	MOV	R6,data addr
7C	2	MOV	R4,#data	AF	2	MOV	R7,data addr
7D	2	MOV	R5,#data	B0	2	ANL	C,/bit addr
7E	2	MOV	R6,#data	B1	2	ACALL	code addr
7F	2	MOV	R7,#data	B2	2	CPL	bit addr
80	2	SJMP	code addr	B3	1	CPL	C
81	2	AJMP	code addr	B4	3	CJNE	A,#data,code addr
82	2	ANL	C,bit addr	B5	3	CJNE	A,data addr,code addr
83	1	MOVC	A,@A+PC	B6	3	CJNE	@R0,#data,code addr
84	1	DIV	AB	B7	3	CJNE	@R1,#data,code addr
85	3	MOV	data addr,data addr	B8	3	CJNE	R0,#data,code addr
86	2	MOV	data addr,@R0	B9	3	CJNE	R1,#data,code addr
87	2	MOV	data addr,@R1	BA	3	CJNE	R2,#data,code addr
88	2	MOV	data addr,R0	BB	3	CJNE	R3,#data,code addr
89	2	MOV	data addr,R1	BC	3	CJNE	R4,#data,code addr
8A	2	MOV	data addr,R2	BD	3	CJNE	R5,#data,code addr
8B	2	MOV	data addr,R3	BE	3	CJNE	R6,#data,code addr
8C	2	MOV	data addr,R4	BF	3	CJNE	R7,#data,code addr
8D	2	MOV	data addr,R5	C0	2	PUSH	data addr
8E	2	MOV	data addr,R6	C1	2	AJMP	code addr
8F	2	MOV	data addr,R7	C2	2	CLR	bit addr
90	3	MOV	DPTR,#data	C3	1	CLR	C
91	2	ACALL	code addr	C4	1	SWAP	A
92	2	MOV	bit addr,C	C5	2	XCH	A,data addr
93	1	MOVC	A,@A+DPTR	C6	1	XCH	A,@R0
94	2	SUBB	A,#data	C7	1	XCH	A,@R1
95	2	SUBB	A,data addr	C8	1	XCH	A,R0
96	1	SUBB	A,@R0	C9	1	XCH	A,R1
97	1	SUBB	A,@R1	CA	1	XCH	A,R2
98	1	SUBB	A,R0	CB	1	XCH	A,R3

SIEMENS AKTIENGESELLSCHAFT

T-49-19-05

Instruction Op Codes in Hexadecimal Order (cont'd)

Hex code	Number of bytes	Mnemonic	Operands	Hex code	Number of bytes	Mnemonic	Operands
CC	1	XCH	A,R4	FD	1	MOV	R5,A
CD	1	XCH	A,R5	FE	1	MOV	R6,A
CE	1	XCH	A,R6	FF	1	MOV	R7,A
CF	1	XCH	A,R7				
D0	2	POP	<i>data addr</i>				
D1	2	ACALL	<i>code addr</i>				
D2	2	SETB	<i>bit addr</i>				
D3	1	SETB	C				
D4	1	DA	A				
D5	3	DJNZ	<i>data addr,code addr</i>				
D6	1	XCHD	A,@R0				
D7	1	XCHD	A,@R1				
D8	2	DJNZ	R0, <i>code addr</i>				
D9	2	DJNZ	R1, <i>code addr</i>				
DA	2	DJNZ	R2, <i>code addr</i>				
DB	2	DJNZ	R3, <i>code addr</i>				
DC	2	DJNZ	R4, <i>code addr</i>				
DD	2	DJNZ	R5, <i>code addr</i>				
DE	2	DJNZ	R6, <i>code addr</i>				
DF	2	DJNZ	R7, <i>code addr</i>				
E0	1	MOVX	A,@DPTR				
E1	2	AJMP	<i>code addr</i>				
E2	1	MOVX	A,@R0				
E3	1	MOVX	A,@R1				
E4	1	CLR	A				
E5	2	MOV	A, <i>data addr</i> *)				
E6	1	MOV	A,@R0				
E7	1	MOV	A,@R1				
E8	1	MOV	A,R0				
E9	1	MOV	A,R1				
EA	1	MOV	A,R2				
EB	1	MOV	A,R3				
EC	1	MOV	A,R4				
ED	1	MOV	A,R5				
EE	1	MOV	A,R6				
EF	1	MOV	A,R7				
F0	1	MOVX	@DPTR,A				
F1	2	ACALL	<i>code addr</i>				
F2	1	MOVX	@R0,A				
F3	1	MOVX	@R1,A				
F4	1	CPL	A				
F5	2	MOV	<i>data addr,A</i>				
F6	1	MOV	@R0,A				
F7	1	MOV	@R1,A				
F8	1	MOV	R0,A				
F9	1	MOV	R1,A				
FA	1	MOV	R2,A				
FB	1	MOV	R3,A				
FC	1	MOV	R4,A				

*) MOV A,ACC is not a valid instruction

T-49-19-05

Absolute Maximum Ratings

Ambient temperature under bias	0 to	70 °C
Storage temperature	- 65 to +	150 °C
Voltage on any pin with respect to ground (V_{SS})	- 0.5 to	+ 7 V
Power dissipation		2 W

Note: Stresses above those listed under "Absolute Maximum Ratings" may cause permanent damage to the device. Exposure to absolute maximum rating conditions for extended periods may affect device reliability.

DC Characteristics

$T_A = 0$ to 70 °C; $V_{CC} = 5 V \pm 10\%$; $V_{SS} = 0 V$

Symbol	Parameter	Limit Values		Unit	Test Condition
		min.	max.		
V_{IL}	Input low voltage	- 0.5	0.8	V	-
V_{IH}	Input high voltage (except RST/ V_{PD} and XTAL 2)	2.0	$V_{CC} + 0.5$	V	-
V_{IH1}	Input high voltage to RST/ V_{PD} for reset, XTAL 2	2.5	$V_{CC} + 0.5$	V	XTAL 1 to V_{SS}
V_{PD}	Power-down voltage to RST/ V_{PD}	4.5	5.5	V	$V_{CC} = 0 V$
V_{OL}	Output low voltage, Ports 1, 2, 3	-	0.45	V	$I_{OL} = 1.6 mA$
V_{OL1}	Output low voltage Port 0, ALE, PSEN	-	0.45	V	$I_{OL} = 3.2 mA$
V_{OH}	Output high voltage, Ports 1, 2, 3	2.4	-	V	$I_{OH} = - 80 \mu A$
V_{OH1}	Output high voltage Port 0, ALE, PSEN	2.4	-	V	$I_{OH} = - 400 \mu A$
I_{IL}	Logical 0 input current Ports 1, 2, 3	-	- 500	μA	$V_{IL} = 0.45 V$
I_{IL2}	Logical 0 input current XTAL 2	-	- 2.0	mA	XTAL 1 = V_{SS} $V_{IL} = 0.45 V$
I_{IH1}	Input high current to RST/ V_{PD} for reset	-	500	μA	$V_{IN} = V_{CC} - 1.5 V$
I_{LI}	Input leakage current to port 0, EA	-	± 10	μA	$0 V < V_{IN} < V_{CC}$
I_{CC}	Power supply current	-	175	mA	All outputs disconnected
I_{PD}	Power down current	-	15	mA	$V_{CC} = 0 V$
C_{IO}	Capacitance of I/O buffer	-	10	pF	$f_c = 1 MHz$

SIEMENS AKTIENGESELLSCHAFT

T-49-19-05

AC Characteristics $T_A = 0\text{ }^{\circ}\text{C}$ to $70\text{ }^{\circ}\text{C}$; $V_{CC} = 5\text{ V} \pm 10\%$; $V_{SS} = 0\text{ V}$ $(C_L$ for port 0, ALE and PSEN outputs = 100 pF ; C_L for all other outputs = 80 pF)**Program Memory Characteristics**

Symbol	Parameter	Limit Values				Unit
		12 MHz clock		Variable clock $1/t_{CLCL} = 1.2\text{ MHz to }12\text{ MHz}$		
		min.	max.	min.	max.	
t_{LHLL}	ALE pulse width	127	—	$2t_{CLCL}-40$	—	ns
t_{AVLL}	Address setup to ALE	53	—	$t_{CLCL}-30$	—	ns
t_{LLAX1}	Address hold after ALE	48	—	$t_{CLCL}-35$	—	ns
t_{LLIV}	ALE to valid instruction in	—	233	—	$4t_{CLCL}-100$	ns
t_{LLPL}	ALE to PSEN	58	—	$t_{CLCL}-25$	—	ns
t_{PLPH}	PSEN pulse width	215	—	$3t_{CLCL}-35$	—	ns
t_{PLIV}	PSEN to valid instruction in	—	150	—	$3t_{CLCL}-100$	ns
t_{PXIX}	Input instruction hold after $\overline{\text{PSEN}}$	0	—	0	—	ns
t_{PXIZ1}	Input instruction float after $\overline{\text{PSEN}}$	—	63	—	$t_{CLCL}-20$	ns
t_{PXAV1}	Address valid after $\overline{\text{PSEN}}$	75	—	$t_{CLCL}-8$	—	ns
t_{AVIV}	Address to valid instruction in	—	302	—	$5t_{CLCL}-115$	ns
t_{AZPL}	Address float to PSEN	0	—	0	—	ns

1) Interfacing the SAB 8052A to devices with float times up to 75 ns is permissible. This limited bus contention will not cause any damage to port 0 drivers.

T-49-19-05

External Data Memory Characteristics

Symbol	Parameter	Limit Values				Unit
		12 MHz clock		Variable clock 1/fCLCE 1.2 MHz to 12		
		min.	max.	min.	max.	
$\overline{A}LRH$	\overline{RD} pulse width	400	—	$6t_{CLCL} - 100$	—	ns
$\overline{A}WLWH$	\overline{WR} pulse width	400	—	$6t_{CLCL} - 100$	—	ns
$\overline{A}LAX2$	Address hold after \overline{ALE}	132	—	$2t_{CLCL} - 35$	—	ns
t_{RLDV}	\overline{RD} to valid data in	—	252	—	$5t_{CLCL} - 165$	ns
$\overline{A}RHD\overline{X}$	Data hold after \overline{RD}	0	—	0	—	ns
$\overline{A}RHD\overline{Z}$	Data float after \overline{RD}	—	97	—	$2t_{CLCL} - 70$	ns
$\overline{A}LDV$	\overline{ALE} to valid data in	—	517	—	$8t_{CLCL} - 150$	ns
$\overline{A}VDV$	Address to valid data in	—	585	—	$9t_{CLCL} - 165$	ns
$\overline{A}LLWL$	\overline{ALE} to \overline{WR} or \overline{RD}	200	300	$3t_{CLCL} - 50$	$3t_{CLCL} + 50$	ns
$\overline{A}VWL$	Address to \overline{WR} or \overline{RD}	203	—	$4t_{CLCL} - 130$	—	ns
$\overline{A}WHLH$	\overline{WR} or \overline{RD} high to \overline{ALE} high	43	123	$t_{CLCL} - 40$	$t_{CLCL} + 40$	ns
t_{QVWX}	Data valid to \overline{WR} transition	33	—	$t_{CLCL} - 50$	—	ns
t_{DVWH}	Data setup before \overline{WR}	433	—	$7t_{CLCL} - 150$	—	ns
$\overline{A}WHQ\overline{X}$	Data hold after \overline{WR}	33	—	$t_{CLCL} - 50$	—	ns
t_{RLAZ}	Address float after \overline{RD}	—	0	—	0	ns

T-49-19-05

External Clock Drive XTAL 2

Symbol	Parameter	Limit Values		Unit
		Variable clock Freq = 1.2 MHz to 12 MHz		
		min.	max.	
t_{CLCL}	Oscillator period	83.3	833.3	ns
t_{CHCX}	High time	20	$t_{CLCL} - t_{CLCX}$	ns
t_{CLCX}	Low time	20	$t_{CLCL} - t_{CHCX}$	ns
t_{CLCH}	Rise time	-	20	ns
t_{CHCL}	Fall time	-	20	ns

Waveforms

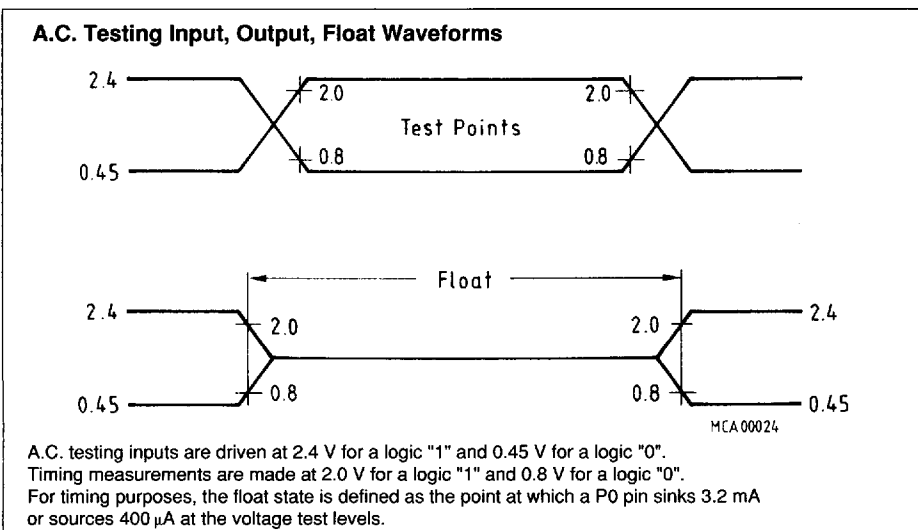
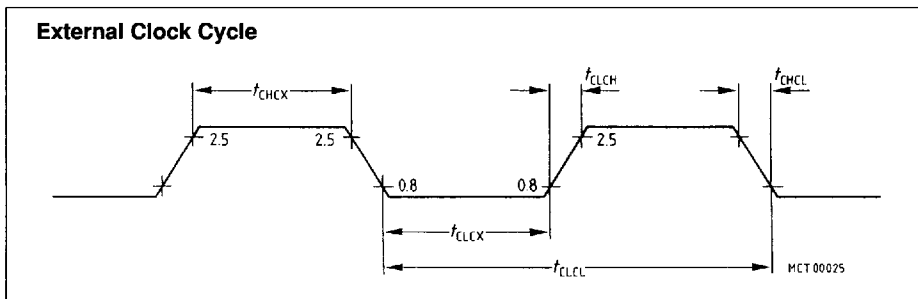

T-49-19-05

Program Memory Read Cycle

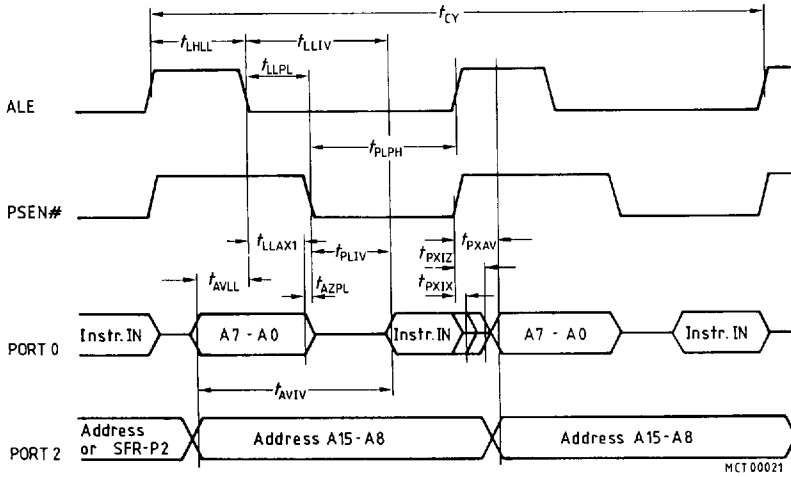

Data Memory Read Cycle

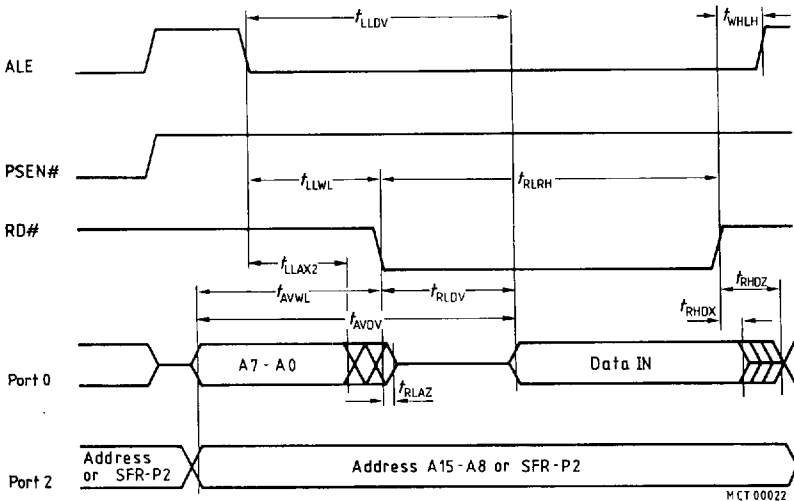

T-49-19-05

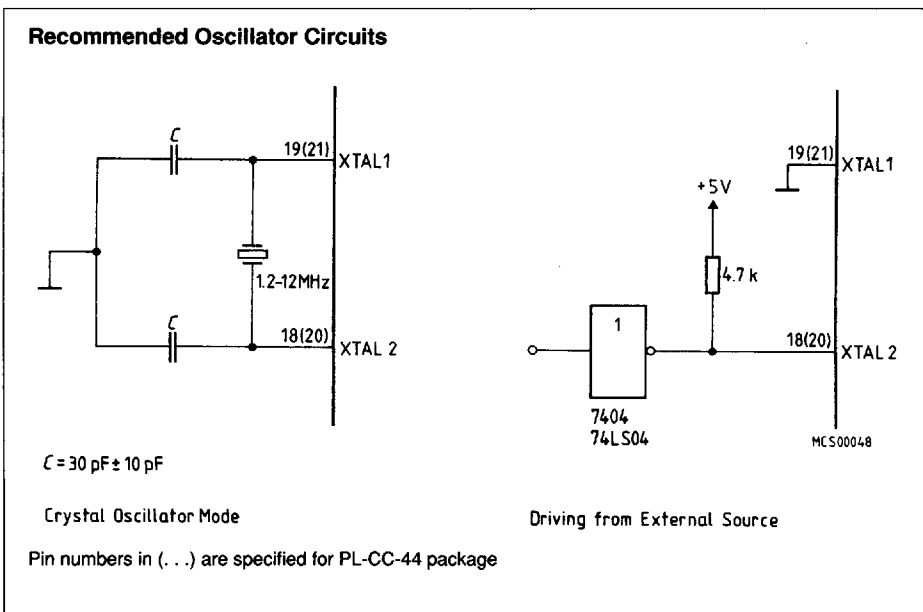
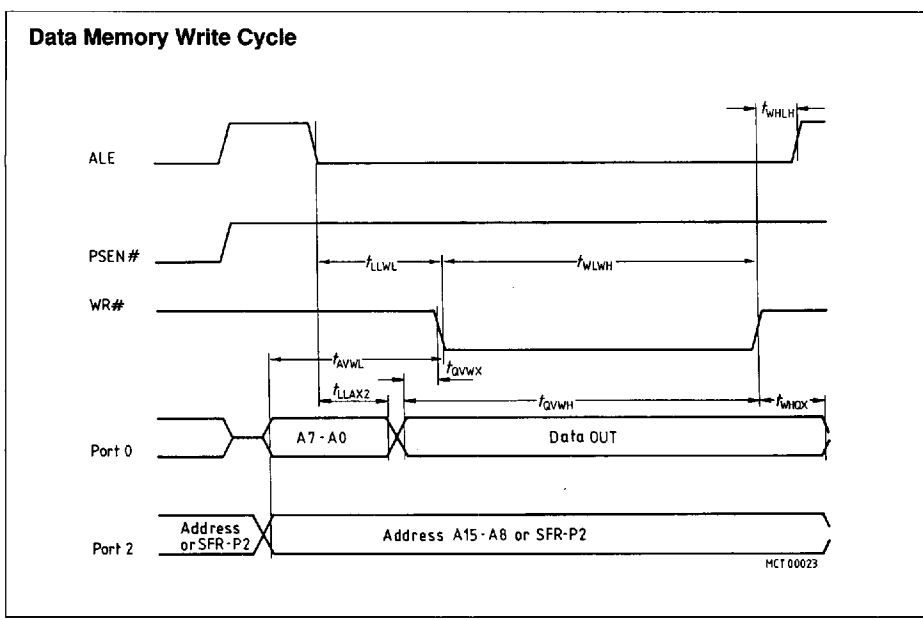

T-49-19-05

ROM Verification Characteristics $T_A = 25\text{ }^\circ\text{C} \pm 5\text{ }^\circ\text{C}$; $V_{CC} = 5\text{ V} \pm 10\%$; $V_{SS} = 0\text{ V}$

Parameter	Symbol	Limit Values		Unit
		min.	max.	
Address to valid data	t_{AVQV}	–	48 t_{CLCL}	ns
ENABLE to valid data	t_{ELQV}	–	48 t_{CLCL}	ns
Data float after ENABLE	t_{EHQZ}	0	48 t_{CLCL}	ns
Oscillator frequency	$1/t_{CLCL}$	4	6	MHz

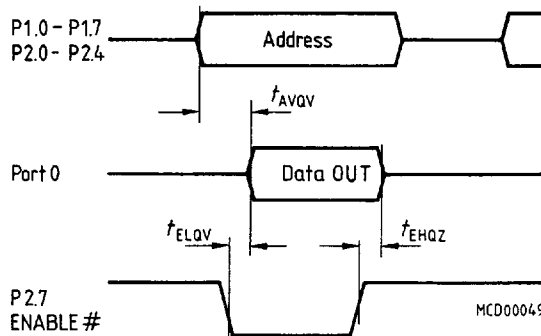
ROM Verification

Address: P1.0–P1.7 = A0–A7
 P2.0–P2.4 = A8–A12

Data: Port 0 = D0–D7

Inputs: P2.5–P2.6, $\overline{PSEN} = V_{SS}$
 ALE, EA = TTL high level
 RST/ V_{PD} = V_{IH1}

Ordering Information

Type	Ordering code	Description
SAB 8052A-P	Q 67120-C195	8-bit single-chip microcontroller with mask-programmable ROM (P-DIP40)
SAB 8032A-P	Q 67120-C196	for external memory (P-DIP40)
SAB 8052A-N	Q 67120-C263	with mask-programmable ROM (PL-CC-44)
SAB 8032A-N	Q 67120-C264	for external memory (PL-CC-44)