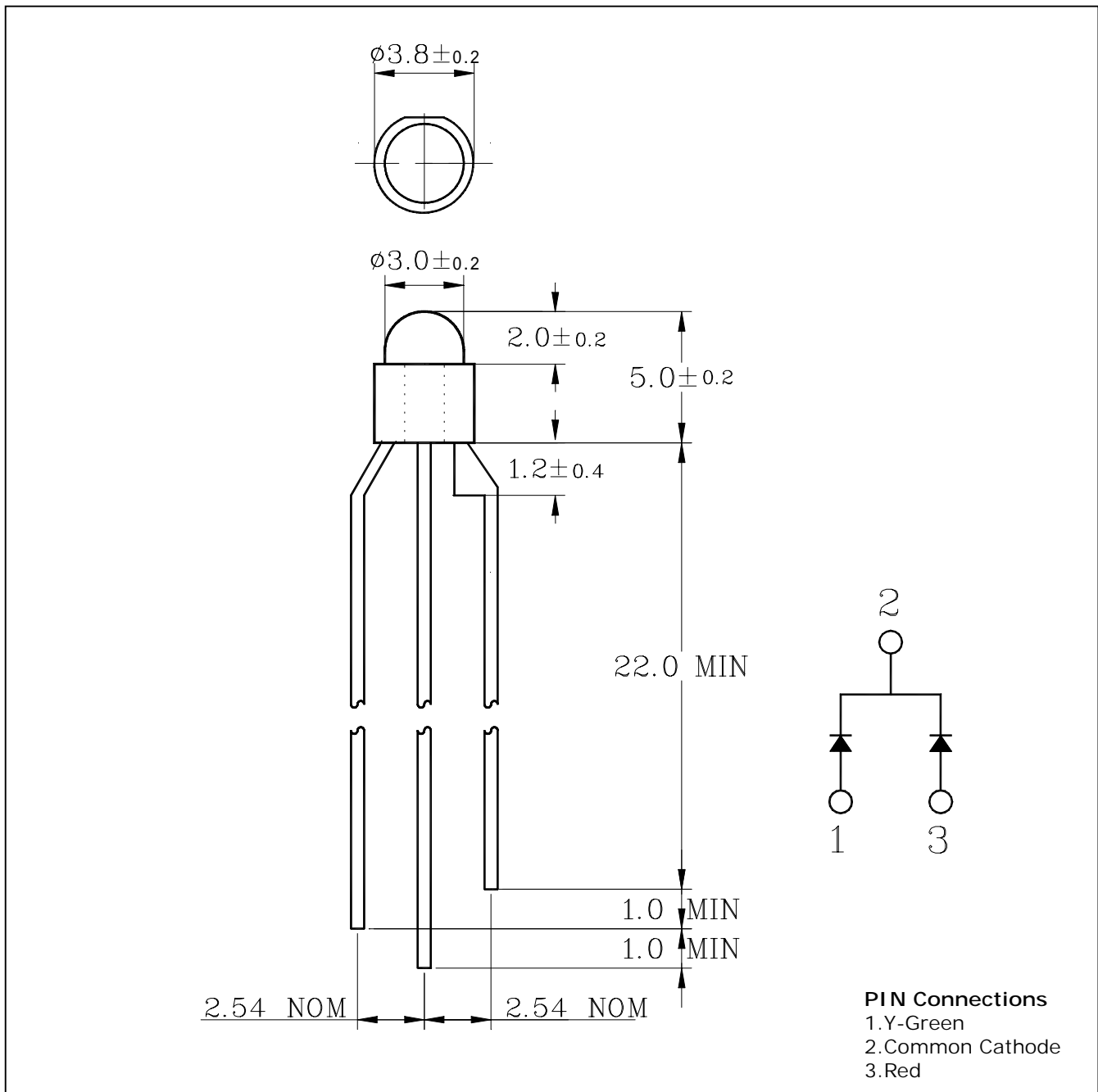

Features

- Milky diffusion lens type
- $\phi 3\text{mm}$ (T-1) all plastic mold type
- Radiation color (Red, Green)
- Low power consumption

Outline Dimensions**unit : mm**

Absolute maximum ratings

| Characteristic | Symbol | Ratings | Unit |
|------------------------|-----------|-------------------|------|
| Power Dissipation | P_D | 85 | mW |
| Forward Current | I_F | 30 | mA |
| *1Peak Forward Current | I_{FP} | 50 | mA |
| Reverse Voltage | V_R | 4 | V |
| Operating Temperature | T_{opr} | -25 85 | |
| Storage Temperature | T_{stg} | -30 100 | |
| Soldering Temperature | T_{sol} | 260 for 5 seconds | |

*1.Duty ratio = 1/16, Pulse width = 0.1ms

Electrical Characteristics

| Characteristic | Symbol | Test Condition | Min. | Typ. | Max. | Unit | |
|--------------------|----------------|---------------------|---------|----------|------|---------------|-----|
| Forward Voltage | V_F | $I_F = 20\text{mA}$ | Red | - | 2.0 | 2.7 | V |
| | | | Y-Green | - | 2.2 | 2.8 | |
| Luminous Intensity | I_V | $I_F = 20\text{mA}$ | Red | 3 | 10 | - | mcd |
| | | | Y-Green | 4 | 12 | - | |
| Peak Wavelength | λ_P | $I_F = 20\text{mA}$ | Red | - | 630 | - | nm |
| | | | Y-Green | - | 570 | - | |
| Spectrum Bandwidth | | $I_F = 20\text{mA}$ | Red | - | 35 | - | nm |
| | | | Y-Green | - | 30 | - | |
| Reverse Current | I_R | $V_R = 4\text{V}$ | - | - | 10 | μA | |
| Half angle | $\theta_{1/2}$ | $I_F = 20\text{mA}$ | - | ± 20 | - | deg | |

Characteristic Diagrams

Fig. 1 $I_F - V_F$

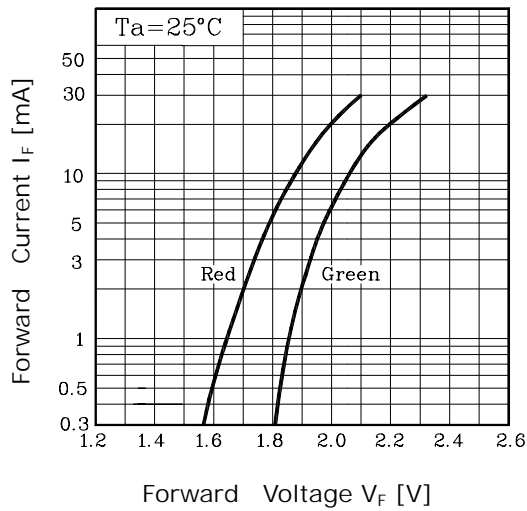

Fig. 2 $I_V - I_F$

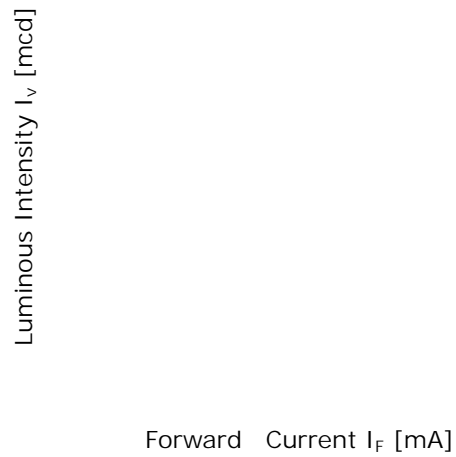

Fig. 3 $I_F - T_a$

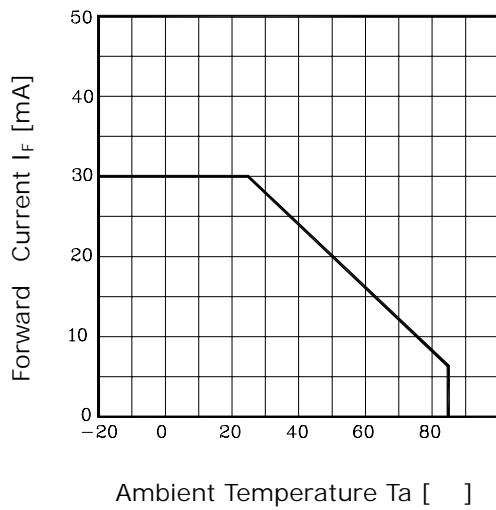

Fig.4 Spectrum Distribution

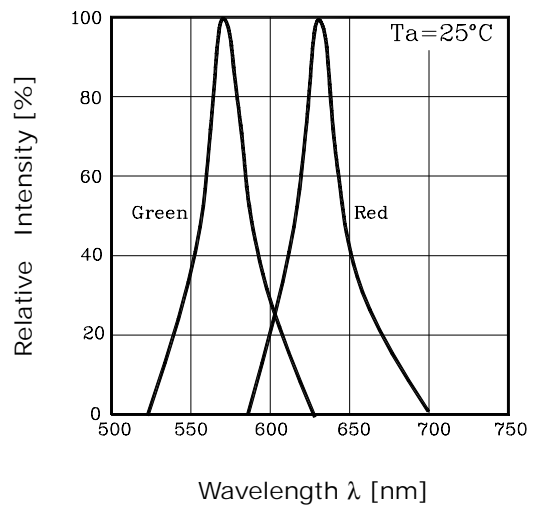

Fig. 5 Radiation Diagram

