

Features

- Milky diffusion lens type
- $\phi 5\text{mm}$ (T-13/4) all plastic mold type
- Radiation color (Red, Green)
- Low power consumption

Outline Dimensions

unit : mm

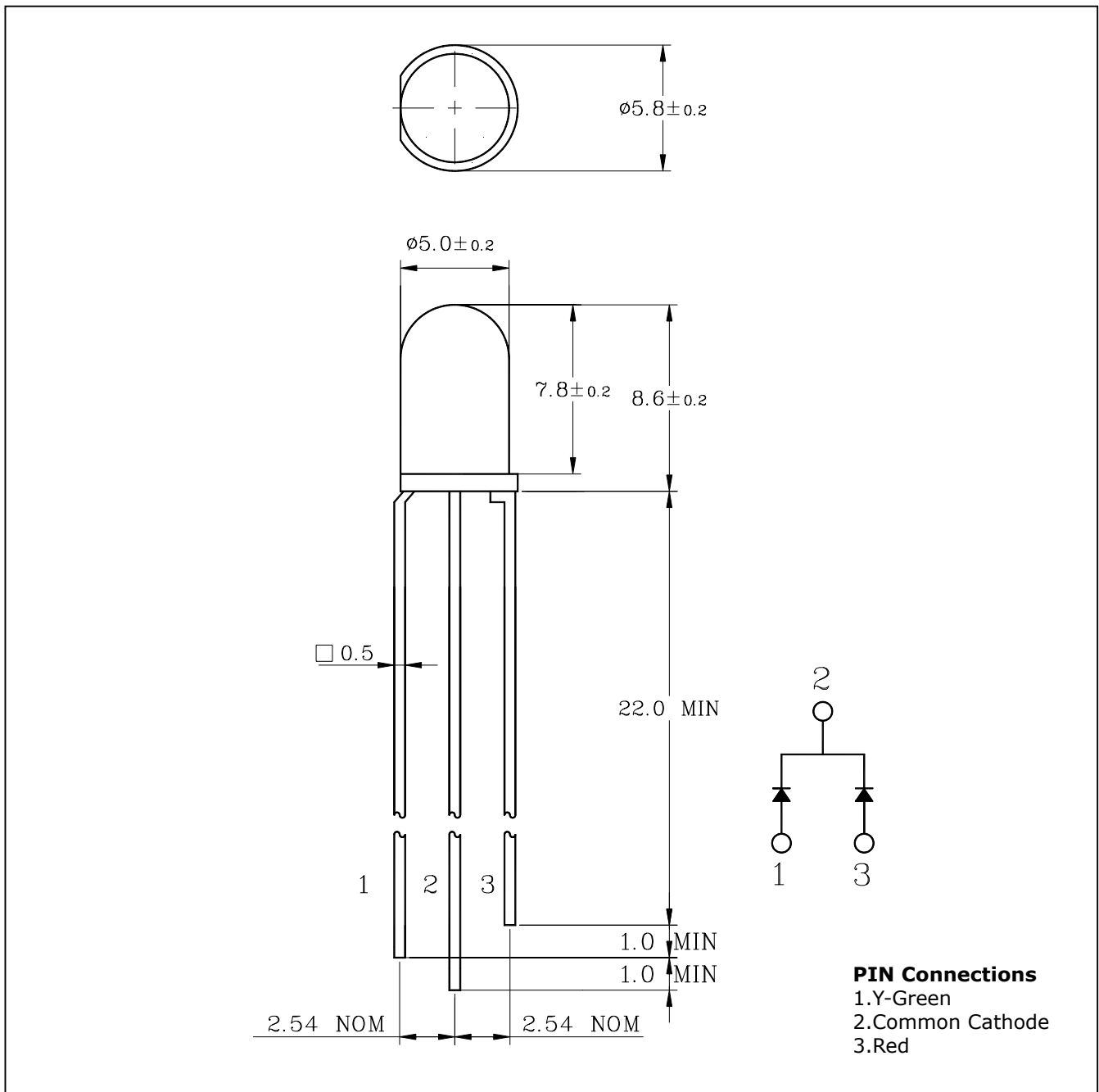

Absolute maximum ratings

Characteristic	Symbol	Ratings	Unit
Power Dissipation	P_D	85	mW
Forward Current	I_F	30	mA
*1Peak Forward Current	I_{FP}	50	mA
Reverse Voltage	V_R	4	V
Operating Temperature	T_{opr}	-25 ~ 85	°C
Storage Temperature	T_{stg}	-30 ~ 100	°C
*2Soldering Temperature	T_{sol}	260°C for 5 seconds	

*1.Duty ratio = 1/16, Pulse width = 0.1ms

*2.Recommended soldering condition ⇒ Attached

Electrical Characteristics

Characteristic	Symbol	Test Condition	Min.	Typ.	Max.	Unit
Forward Voltage	V_F	$I_F= 20mA$	Red	2.0	2.7	V
			Y-Green	2.2	2.8	
Luminous Intensity	I_V	$I_F= 20mA$	Red	8	-	mcd
			Y-Green	12	-	
Peak Wavelength	λ_p	$I_F= 20mA$	Red	630	-	nm
			Y-Green	570	-	
Spectrum Bandwidth	$\Delta \lambda$	$I_F= 20mA$	Red	35	-	nm
			Y-Green	30	-	
Reverse Current	I_R	$V_R=4V$	-	-	10	uA
*3Half angle	$\theta_{1/2}$	$I_F= 20mA$	-	±20	-	deg

*3. $\theta_{1/2}$ is the off-axis angle where the luminous intensity is 1/2 the peak intensity

Characteristic Diagrams

Fig. 1 $I_F - V_F$

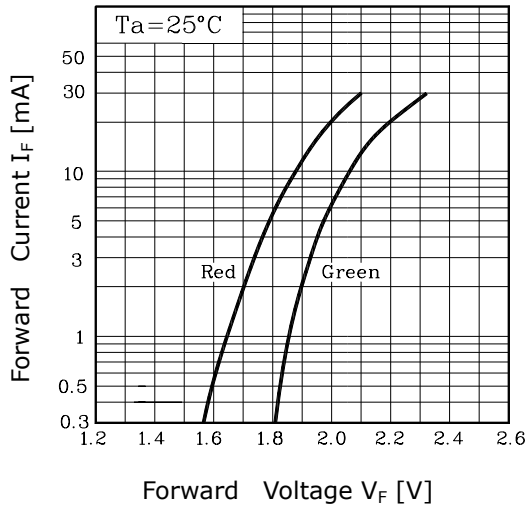

Fig. 2 $I_V - I_F$

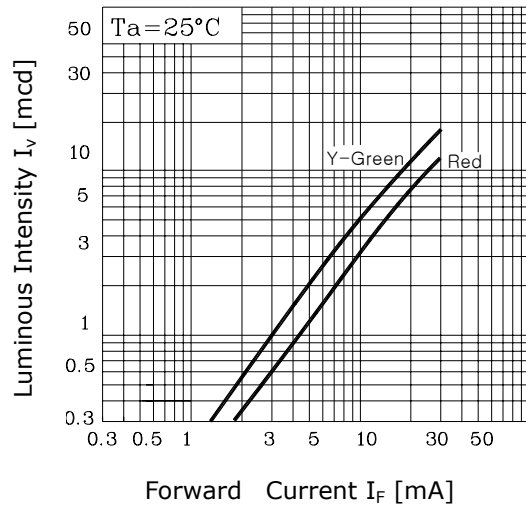

Fig. 3 $I_F - T_a$

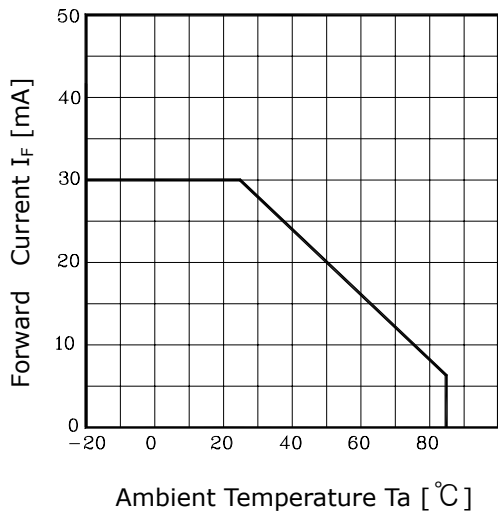

Fig.4 Spectrum Distribution

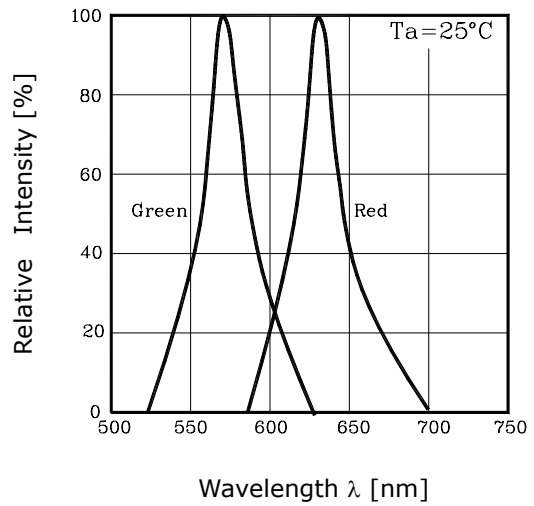

Fig. 5 Radiation Diagram

