



Description

The SAT470 consists of a phototransistor optically coupled to two light emitting diodes. Optical coupling between the input IR LEDs and output phototransistor allows for high isolation levels while maintaining low-level AC or DC signal control capability. The SAT470 provides an optically isolated method of controlling many interface applications such as telecommunications, industrial control and instrumentation circuitry.

The SAT470 comes standard in an ultra-miniature 4 pin SSOP package.

Applications

- Office Automation Equipment
- System Appliances, Measuring Instruments
- Computer Terminals, PLCs
- Telecom / Datacom
- Home Appliances
- Digital Logic Inputs
- Fax / Modems
- Power Supplies

Schematic Diagram

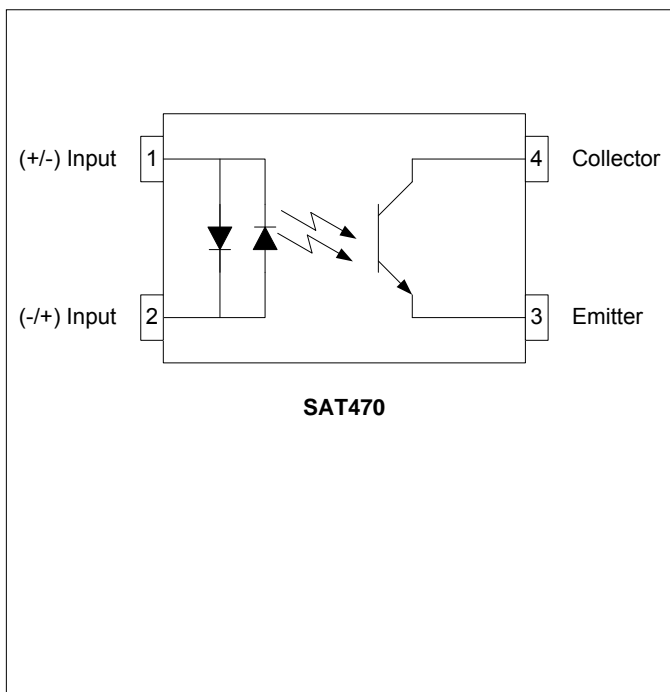

Features

- Ultra miniature 4 pin SSOP package
- Low input power consumption
- High stability
- CTR Range 20 – 400%
- High Isolation Voltage (3750V_{RMS})
- Long Life / High Reliability
- RoHS / Pb-Free / REACH Compliant

Agency Approvals

UL/C-UL: File # E201932
VDE: File # 40035191 (EN 60747-5-2)

Absolute Maximum Ratings

The values indicated are absolute stress ratings. Functional operation of the device is not implied at these or any conditions in excess of those defined in electrical characteristics section of this document. Exposure to absolute Maximum Ratings may cause permanent damage to the device and may adversely affect reliability.

Storage Temperature-55 to +125°C
 Operating Temperature-40 to +100°C
 Continuous Input Current50mA
 Transient Input Current500mA
 Reverse Input Control Voltage6V
 Input Power Dissipation40mW
 Total Power Dissipation200mW
 Solder Temperature – Wave (10sec).....260°C
 Solder Temperature – IR Reflow (10sec).....260°C

Ordering Information

Part Number	Description
SAT470	4 pin SSOP, (170/Tube)
SAT470-TR	4 pin SSOP, Tape and Reel (3000/Reel)

NOTE: Suffixes listed above are not included in marking on device for part number identification

Electrical Characteristics, $T_A = 25^\circ\text{C}$ (unless otherwise specified)

Parameter	Symbol	Min.	Typ.	Max.	Units	Test Conditions
Input Specifications						
LED Forward Voltage	V_F	-	1.2	1.4	V	$I_F = \pm 20\text{mA}$
Terminal Capacitance	C_t	-	60	250	pF	$V=0, f=1\text{KHz}$
Output Specifications						
Collector-Emitter Voltage	V_{CEO}	80	-	-	V	$I_C=100\mu\text{A}$
Emitter-Collector Voltage	V_{COE}	7	-	-	V	$I_E=10\mu\text{A}$
Collector Dark Current	I_{CEO}	-	-	100	nA	$V_{CE}=50\text{V}, I_F=0\text{mA}$
Floating Capacitance	C_f	-	0.8	1.0	pF	$V=0, f=1\text{MHz}$
Cut-Off Frequency	f_c	-	80	-	kHz	$V_{CE}=2\text{V}, I_C=20\text{mA}, R_L=100\Omega, -3\text{dB}$
Saturation Voltage	$V_{CE(sat)}$	-	0.1	0.4	V	$I_F=\pm 20\text{mA}, I_C=1\text{mA}$
Coupled Specifications						
Rise Time	T_R	-	3	-	μS	$I_C=\pm 2\text{mA}, V_{CC}=2\text{V}, R_L=100\Omega$
Fall Time	T_F	-	4	-	μS	$I_C=\pm 2\text{mA}, V_{CC}=2\text{V}, R_L=100\Omega$
Current Transfer Ratio	CTR	20	-	400	%	$I_F=\pm 1\text{mA}, V_{CE}=5\text{V}$
(-A Binning)	CTR	50	-	250	%	$I_F=\pm 1\text{mA}, V_{CE}=5\text{V}$
Isolation Specifications						
Isolation Voltage	V_{ISO}	3,750	-	-	V_{RMS}	$RH \leq 50\%, t=1\text{min}$
Input-Output Resistance	R_{I-O}	-	10^{12}	-	Ω	$V_{I-O} = 500V_{DC}$

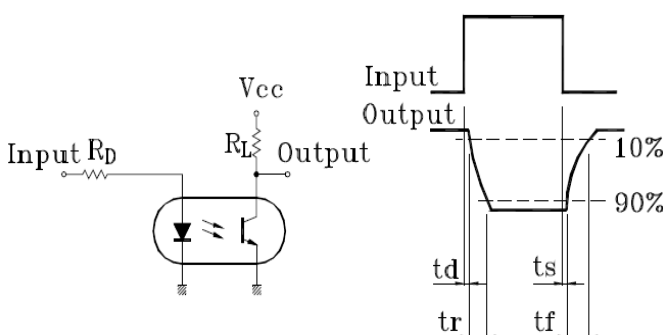
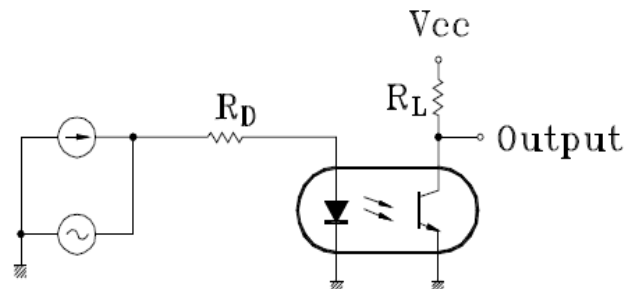
Test Circuit: Response Time

Test Circuit: Frequency Response

SAT470 Performance & Characteristics Plots, $T_A = 25^\circ\text{C}$ (unless otherwise specified)

Figure 1: Forward Current (I_F) vs. Temperature ($^\circ\text{C}$)

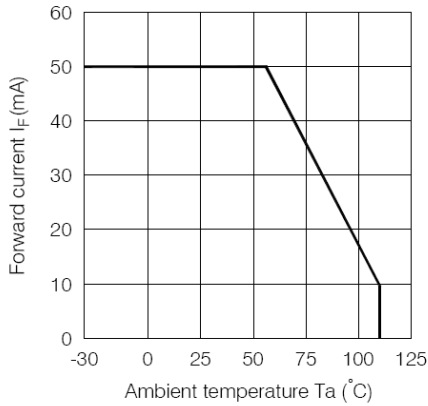

Figure 2: Collector Power Dissipation (P_C) vs. Temperature ($^\circ\text{C}$)

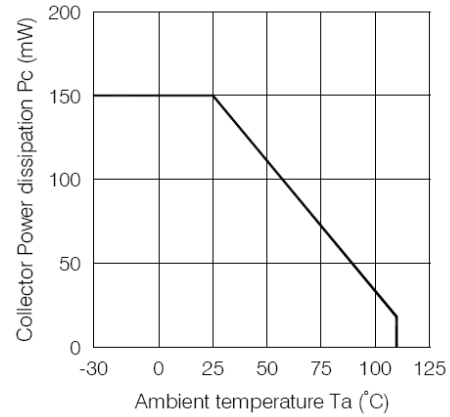

Figure 3: Collector-Emitter Saturation Voltage ($V_{CE(SAT)}$) vs. Forward Current (I_F)

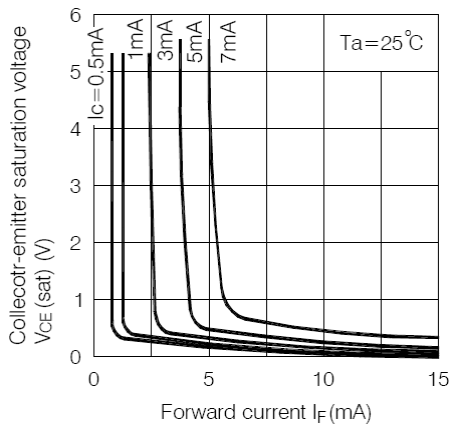

Figure 4: Forward Current (I_F) vs. Forward Voltage (V_F)

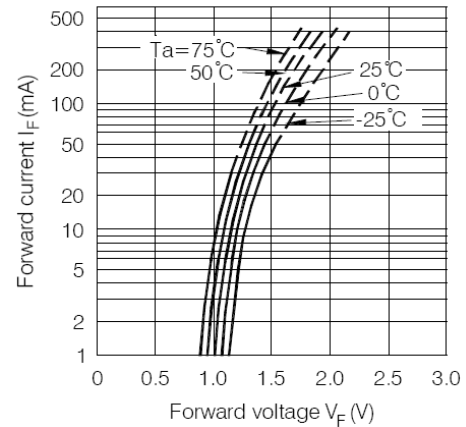

Figure 5: Collector Current (I_C) vs. Collector-Emitter Voltage (V_{CE})

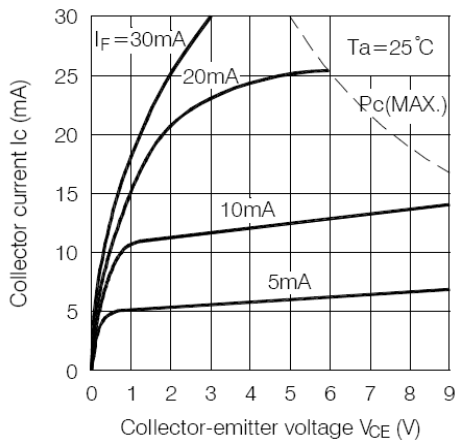
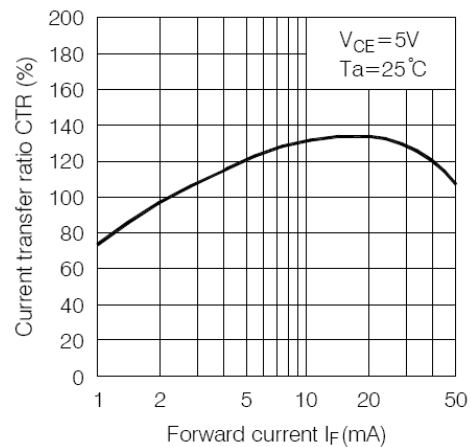

Figure 6: Current Transfer Ratio (CTR) vs. Forward Current (I_F)



SAT470 Performance & Characteristics Plots, $T_A = 25^\circ\text{C}$ (unless otherwise specified)

Figure 7: Relative CTR (%) vs. Temperature ($^\circ\text{C}$)

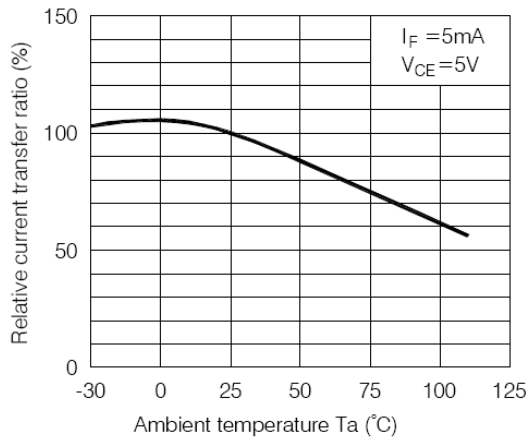

Figure 8: Collector-Emitter Saturation Voltage ($V_{CE(\text{SAT})}$) vs. Temperature ($^\circ\text{C}$)

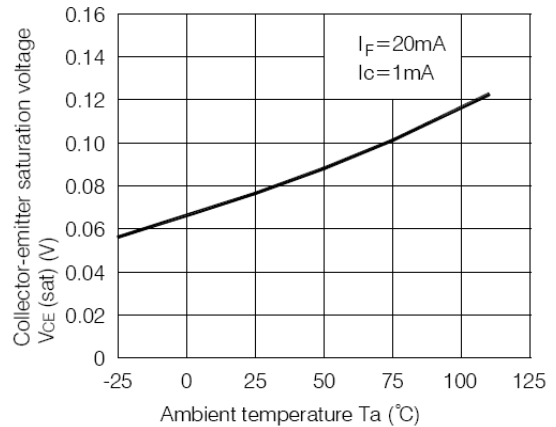

Figure 9: Collector Dark Current (I_{CE0}) vs. Temperature ($^\circ\text{C}$)

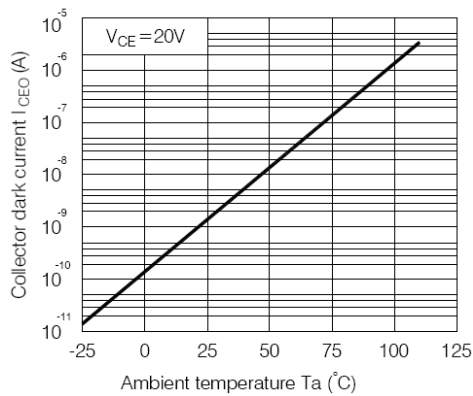

Figure 10: Response Times vs. Load Resistance (R_L)

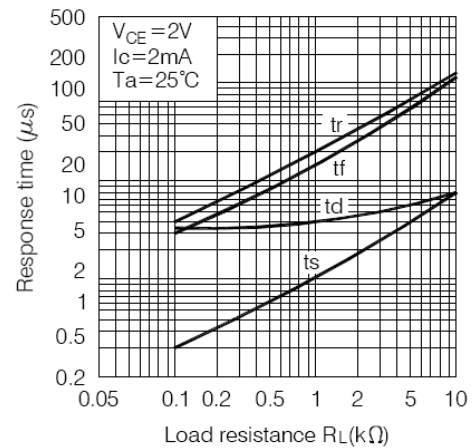
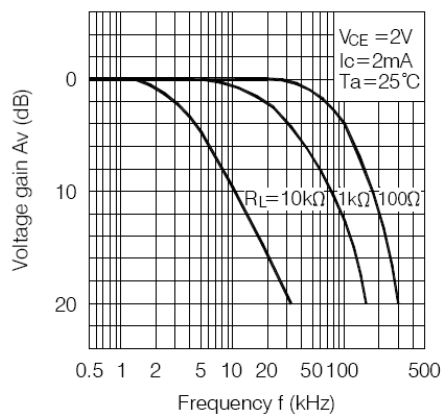
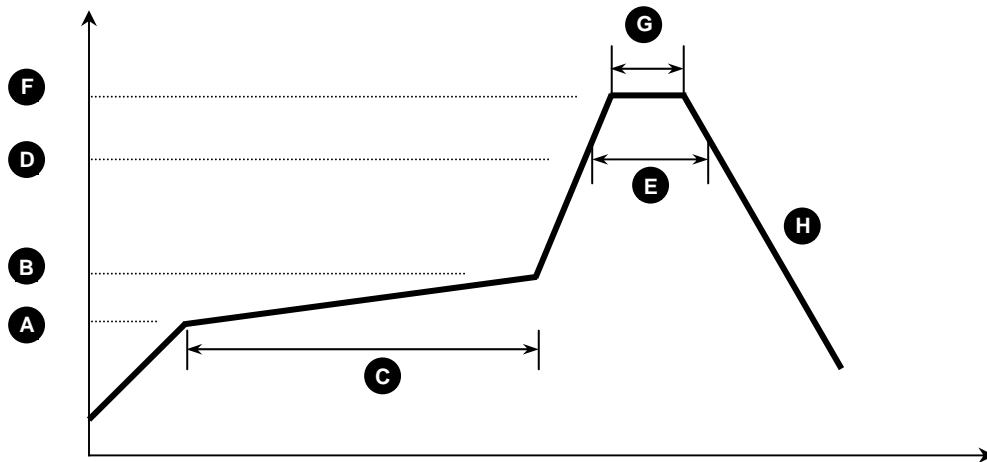

Figure 11: Frequency Response Characteristics



SAT470 Solder Reflow Temperature Profile Recommendations
(1) *Infrared Reflow:*

Refer to the following figure as an example of an optimal temperature profile for single occurrence infrared reflow. Soldering process should not exceed temperature or time limits expressed herein. Surface temperature of device package should not exceed 250°C:



Process Step	Description	Parameter
A	Preheat Start Temperature (°C)	150°C
B	Preheat Finish Temperature (°C)	180°C
C	Preheat Time (s)	90 - 120s
D	Melting Temperature (°C)	230°C
E	Time above Melting Temperature (s)	30s
F	Peak Temperature, at Terminal (°C)	260°C
G	Dwell Time at Peak Temperature (s)	10s
H	Cool-down (°C/s)	<6°C/s

(2) *Wave Solder:*

Maximum Temperature: 260°C (at terminal)
 Maximum Time: 10s
 Pre-heating: 100 - 150°C (30 - 90s)
 Single Occurrence

(3) *Hand Solder:*

Maximum Temperature: 350°C (at tip of soldering iron)
 Maximum Time: 3s
 Single Occurrence

SAT470 Package Dimensions

4 PIN SSOP Package

Note: All dimensions in millimeters [mm]

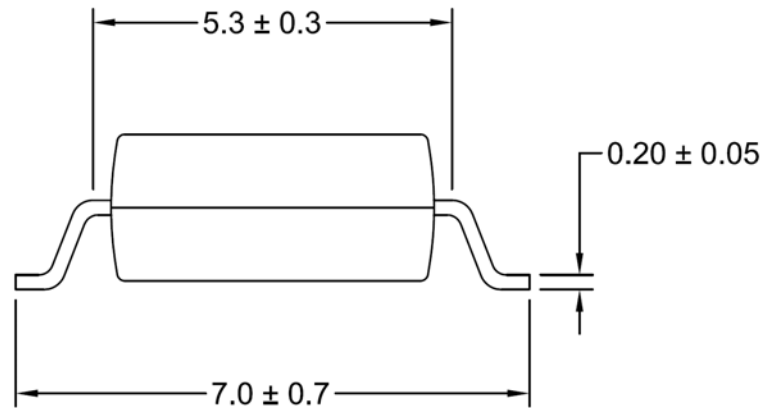
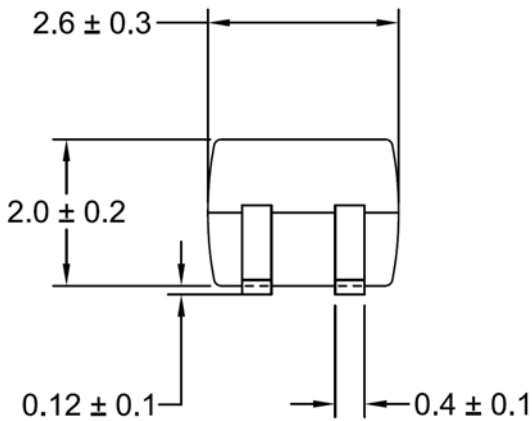
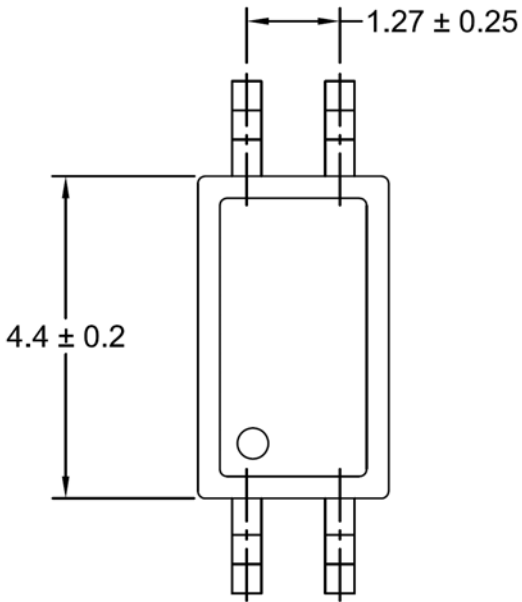

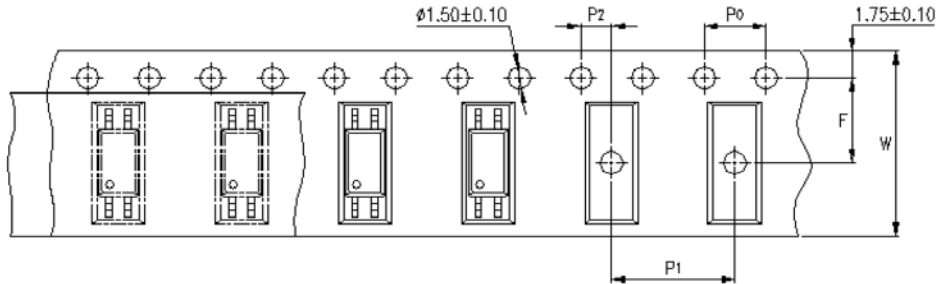
SAT470 Packaging Specifications
Tape & Reel Specifications (T&R)
Note: All dimensions in millimeters [mm]

Specification	Symbol	Dimensions, mm (inches)
Tape Width	W	12 ± 0.3 (0.47)
Sprocket Hole Pitch	P0	4 ± 0.1 (0.15)
Compartment Location	F P2	5.5 ± 0.1 (0.217) 2 ± 0.1 (0.079)
Compartment Pitch	P1	12 ± 0.1 (0.472)

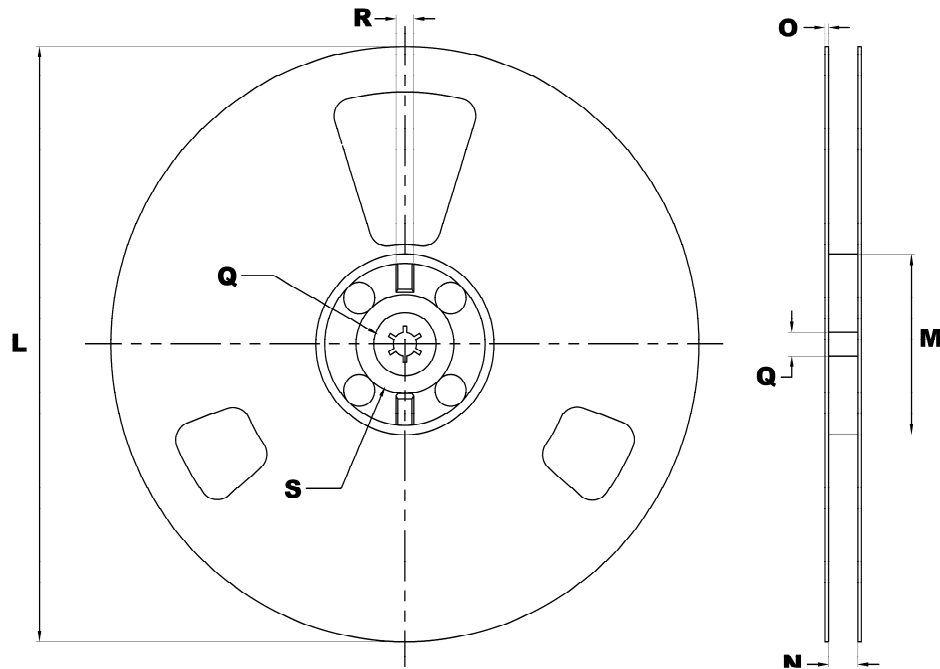

L	M	N	O	Q	R	S
330±2	101.6±1	16.4+0.2	2.0±0.2	R13±0.5	1.50±0.5	R10±1

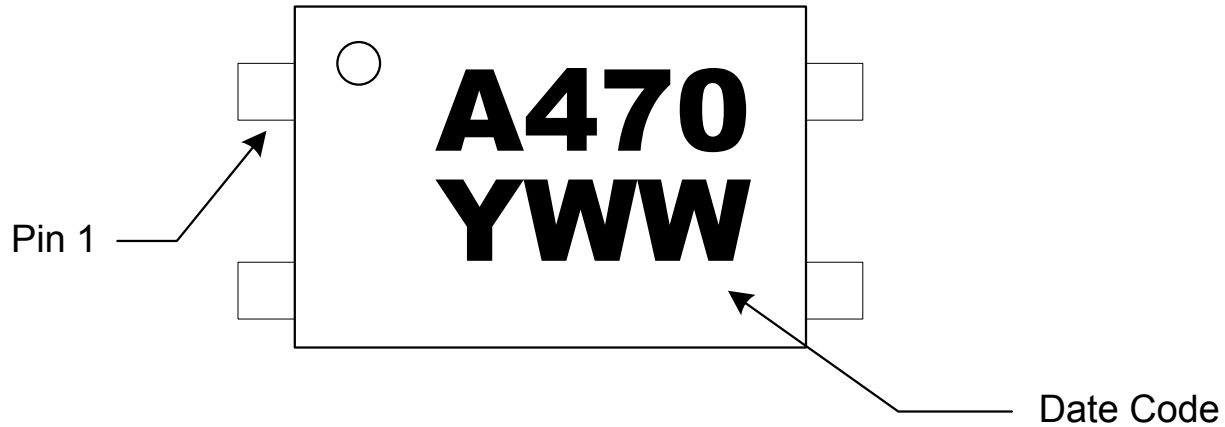
SAT470 Package Marking**DISCLAIMER**

Solid State Optronics (SSO) makes no warranties or representations with regards to the completeness and accuracy of this document. SSO reserves the right to make changes to product description, specifications at any time without further notices. SSO shall not assume any liability arising out of the application or use of any product or circuit described herein. Neither circuit patent licenses nor indemnity are expressed or implied. Except as specified in SSO's Standard Terms & Conditions, SSO disclaims liability for consequential or other damage, and we make no other warranty, expressed or implied, including merchantability and fitness for particular use.

LIFE SUPPORT POLICY

SSO does not authorize use of its devices in life support applications wherein failure or malfunction of a device may lead to personal injury or death. Users of SSO devices in life support applications assume all risks of such use and agree to indemnify SSO against any and all damages resulting from such use. Life support devices are defined as devices or systems which, (a) are intended for surgical implant into the body, or (b) support or sustain life, and (c) whose failure to perform when used properly in accordance with instructions for use can be reasonably expected to result in significant injury to the user, or (d) a critical component of a life support device or system whose failure can be reasonably expected to cause failure of the life support device or system, or to affect its safety or effectiveness.