

# SB1020FCT THRU SB10200FCT

## List

List.....	1
Package outline.....	2
Features.....	2
Mechanical data.....	2
Maximum ratings .....	2
Rating and characteristic curves.....	3
Pinning information.....	4
Marking.....	4
Tube packing.....	4
Suggested thermal profiles for soldering processes.....	5
High reliability test capabilities.....	6

# SB1020FCT THRU SB10200FCT

## 10A Power Schottky Barrier Rectifiers - 20V-200V

### Features

- For use in low voltage, high frequency inverters, free wheeling, and polarity protection applications
- Offer 5.0A half wave and 10A full wave rectification.
- Low power loss, high efficiency.
- High current capability, low forward voltage drop.
- High surge capability.
- Guardring for overvoltage protection.
- Ultra high-speed switching.
- Silicon epitaxial planar chip, metal silicon junction.
- Lead-free parts meet environmental standards of MIL-STD-19500 /228
- Suffix "-H" indicates Halogen-free parts, ex. SB1020FCT-H.

### Mechanical data

- Epoxy : UL94-V0 rated flame retardant
- Case : JEDEC ITO-220AB molded plastic body over passivated chip
- Lead : Axial leads, solderable per MIL-STD-202, Method 208 guaranteed
- Polarity: As marked
- Mounting Position : Any
- Weight : Approximated 1.70 gram

### Package outline

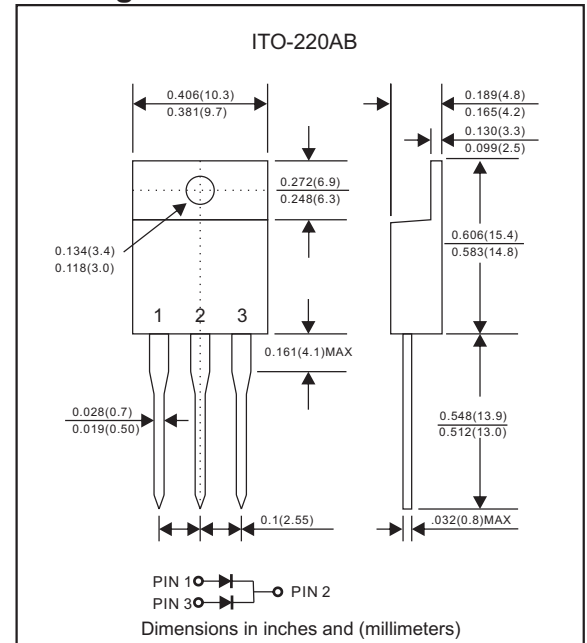

### Maximum ratings (AT $T_A=25^{\circ}\text{C}$ unless otherwise noted)

PARAMETER	SYMBOLS	SB 1020FCT	SB 1040FCT	SB 1045FCT	SB 1060FCT	SB 1080FCT	SB 10100FCT	SB 10150FCT	SB 10200FCT	UNIT
Maximum repetitive peak reverse voltage	$V_{RRM}$	20	40	45	60	80	100	150	200	V
Maximum RMS voltage	$V_{RMS}$	14	28	31.5	42	56	70	105	140	V
Maximum DC blocking voltage	$V_{DC}$	20	40	45	60	80	100	150	200	V
Maximum average forward rectified current	$I_o$	10								A
Peak forward surge current 8.3ms single half sine-wave(JEDEC method)	$I_{FSM}$	125								A
Operating junction temperature range	$T_J$	-55 to +125			-55 to +150					$^{\circ}\text{C}$
Storage temperature range	$T_{STG}$	-65 to +175								$^{\circ}\text{C}$

### Electrical Characteristics (AT $T_A=25^{\circ}\text{C}$ unless otherwise noted)

PARAMETER	SYMBOLS	SB 1020FCT	SB 1040FCT	SB 1045FCT	SB 1060FCT	SB 1080FCT	SB 10100FCT	SB 10150FCT	SB 10200FCT	UNIT
Maximum forward voltage per leg at $I_F=5\text{A}$	$V_F$	0.55			0.75	0.85		0.90	0.92	V
Maximum DC reverse current at $T_J=25^{\circ}\text{C}$ at rated DC blocking voltage at $T_J=100^{\circ}\text{C}$ per leg	$I_R$					0.5 50				mA mA

### Thermal Characteristics

PARAMETER	SYMBOLS	SB 1020FCT	SB 1040FCT	SB 1045FCT	SB 1060FCT	SB 1080FCT	SB 10100FCT	SB 10150FCT	SB 10200FCT	UNIT
Typical thermal resistance junction to case per leg	$R_{\theta JC}$	3.0								$^{\circ}\text{C}/\text{W}$

# Rating and characteristic curves (SB1020FCT THRU SB10200FCT)

Fig.1 - Forward Current Derating Curve

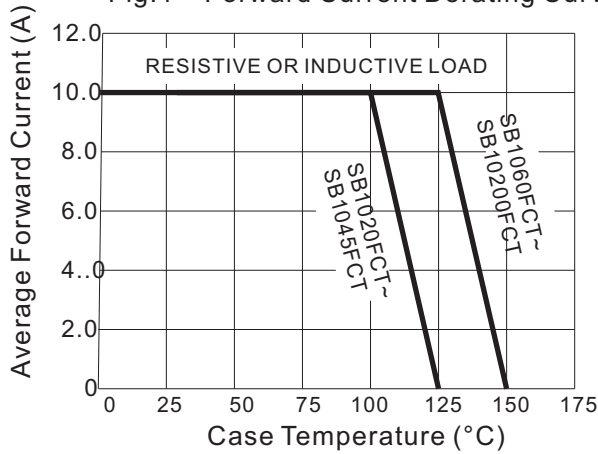

Fig. 2 - Maximum Non-Repetitive Peak Forward Surge Current

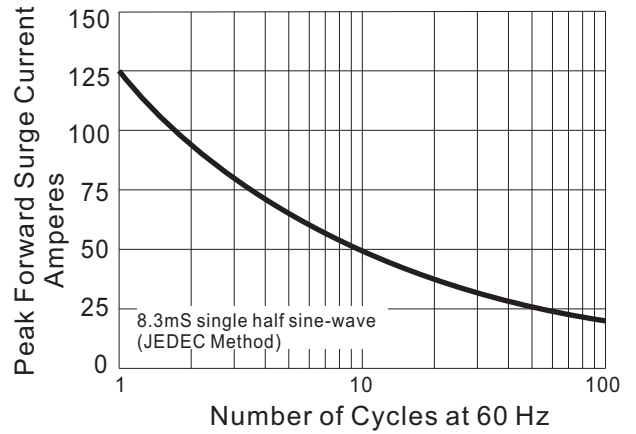

FIG.3-TYPICAL REVER CHARACTERISTICS

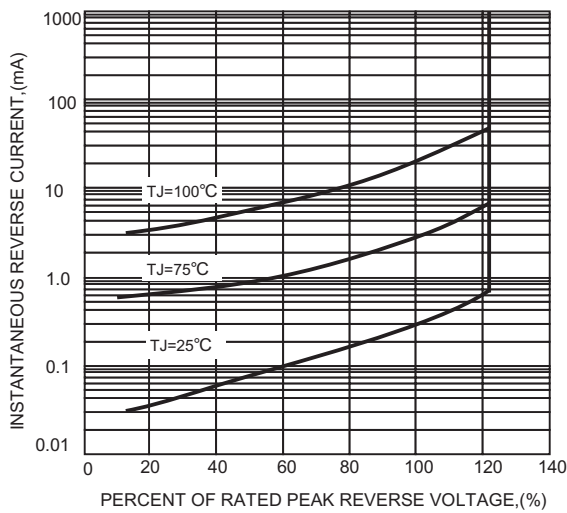

FIG.4-TYPICAL FORWARD CHARACTERISTICS

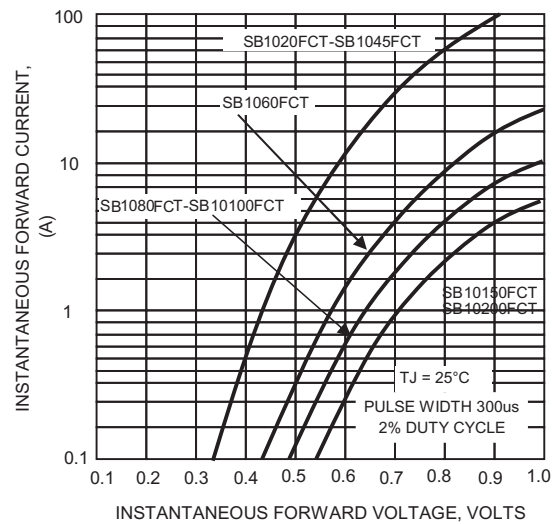
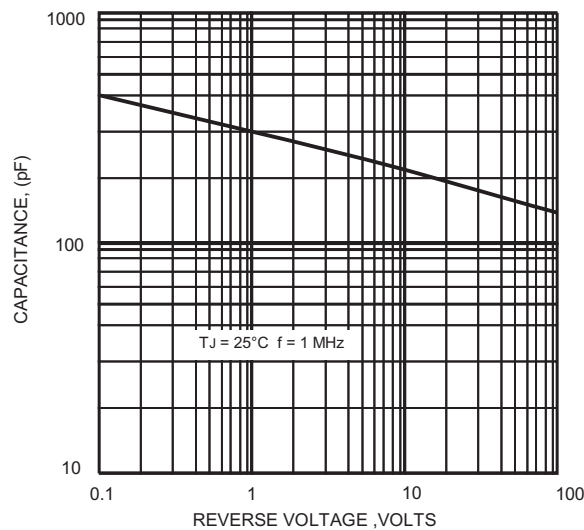
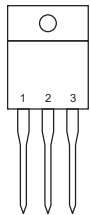
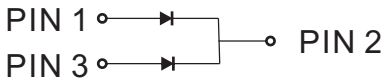

FIG.5-TYPICAL JUNCTION CAPACITANCE



# SB1020FCT THRU SB10200FCT

## Pinning information

Pin	Simplified outline	Symbol
Pin1 anode Pin2 cathode Pin3 anode		

## Marking

Type number	Marking code
SB1020FCT	SB1020FCT
SB1040FCT	SB1040FCT
SB1045FCT	SB1045FCT
SB1060FCT	SB1060FCT
SB1080FCT	SB1080FCT
SB10100FCT	SB10100FCT
SB10150FCT	SB10150FCT
SB10200FCT	SB10200FCT

## Tube packing

PACKAGE	TUBE (pcs)	TUBE SIZE (m/m)	BOX (pcs)	INNER BOX (m/m)	CARTON SIZE (m/m)	CARTON (pcs)	APPROX. GROSS WEIGHT (kg)
ITO-220AB	50	525*32*7.0	1000	555*150*40	580*230*175	5,000	15.0

# SB1020FCT THRU SB10200FCT

## Suggested thermal profiles for soldering processes

### 1. Lead free temperature profile wave-soldering

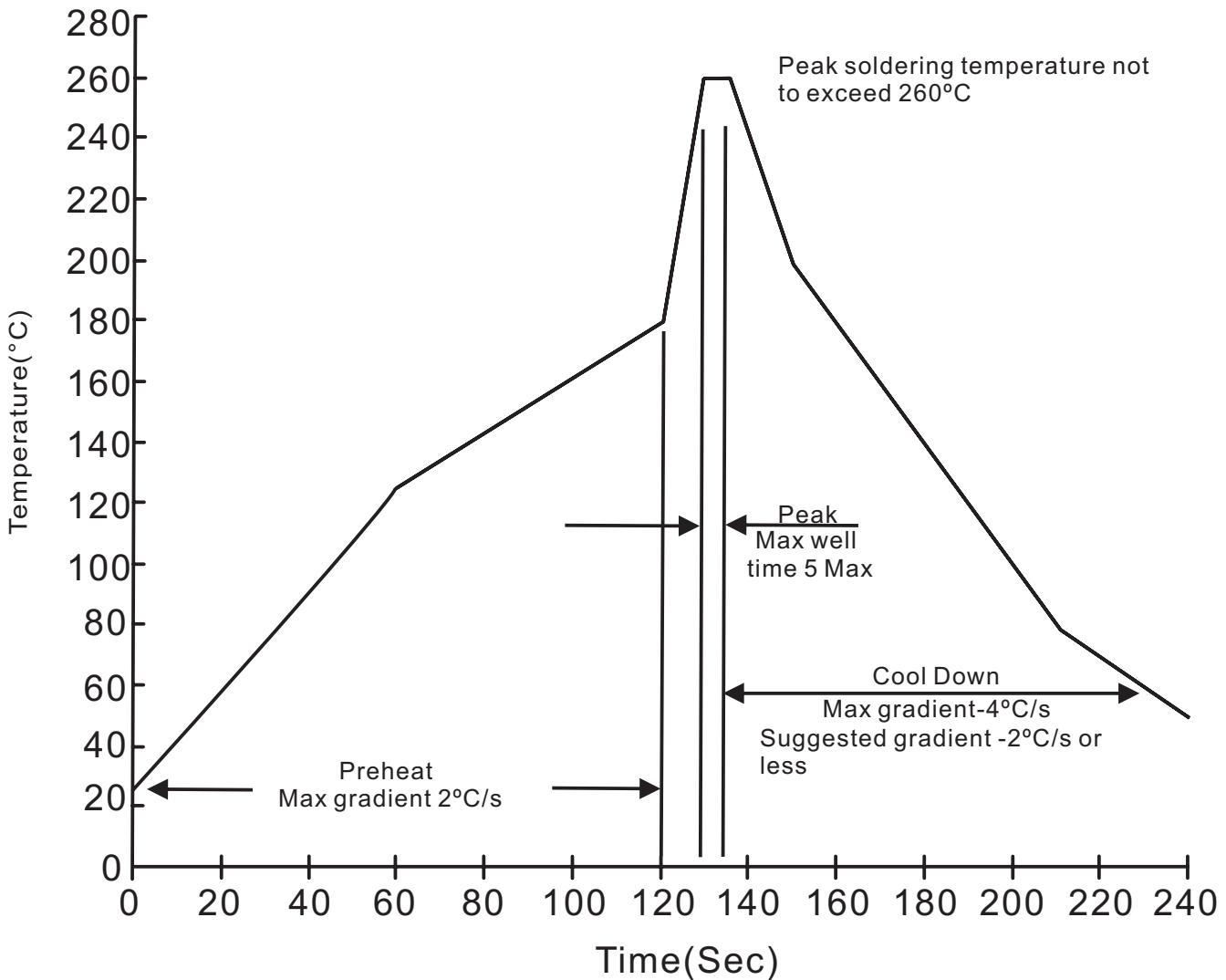

**SB1020FCT THRU SB10200FCT****High reliability test capabilities**

Item Test	Conditions	Reference
1. Solder Resistance	at $260\pm 5^{\circ}\text{C}$ for $10\pm 2\text{sec}$ . immerse body into solder $1/16''\pm 1/32''$	MIL-STD-750D METHOD-2031
2. Solderability	at $245\pm 5^{\circ}\text{C}$ for 5 sec.	MIL-STD-202F METHOD-208
3. High Temperature Reverse Bias	$V_R=80\%$ rate at $T_J=125^{\circ}\text{C}$ for 168 hrs.	MIL-STD-750D METHOD-1038
4. Forward Operation Life	Rated average rectifier current at $T_A=25^{\circ}\text{C}$ for 500hrs.	MIL-STD-750D METHOD-1027
5. Intermittent Operation Life	$T_A = 25^{\circ}\text{C}$ , $I_F = I_O$ On state: power on for 5 min. off state: power off for 5 min. on and off for 500 cycles.	MIL-STD-750D METHOD-1036
6. Pressure Cooker	$15P_{SIG}$ at $T_A=121^{\circ}\text{C}$ for 4 hrs.	JESD22-A102
7. Temperature Cycling	$-55^{\circ}\text{C}$ to $+125^{\circ}\text{C}$ dwelled for 30 min. and transferred for 5min. total 10 cycles.	MIL-STD-750D METHOD-1051
8. Forward Surge	8.3ms single half sine-wave , one surge.	MIL-STD-750D METHOD-4066-2
9. Humidity	at $T_A=85^{\circ}\text{C}$ , RH=85% for 1000hrs.	MIL-STD-750D METHOD-1021
10. High Temperature Storage Life	at $175^{\circ}\text{C}$ for 1000 hrs.	MIL-STD-750D METHOD-1031