

SB3020FCT THRU SB30200FCT

List

List..... 1

Package outline..... 2

Features..... 2

Mechanical data..... 2

Maximum ratings2

Rating and characteristic curves..... 3

Pinning information.....4

Marking..... 4

Tube packing.....4

Suggested thermal profiles for soldering processes..... 5

High reliability test capabilities.....6

SB3020FCT THRU SB30200FCT

30A Power Schottky Barrier Rectifiers - 20V-200V

Features

- For use in low voltage, high frequency inverters, free wheeling, and polarity protection applications
- Offer 15A half wave and 30A full wave rectification.
- Low power loss, high efficiency.
- High current capability, low forward voltage drop.
- High surge capability.
- Guardring for overvoltage protection.
- Ultra high-speed switching.
- Silicon epitaxial planar chip, metal silicon junction.
- Lead-free parts meet environmental standards of MIL-STD-19500 /228
- Suffix "-H" indicates Halogen-free parts, ex. SB3020FCT-H.

Mechanical data

- Epoxy : UL94-V0 rated flame retardant
- Case : JEDEC ITO-220AB molded plastic body over passivated chip
- Lead : Axial leads, solderable per MIL-STD-202, Method 208 guaranteed
- Polarity: As marked
- Mounting Position : Any
- Weight : Approximated 1.70 gram

Package outline

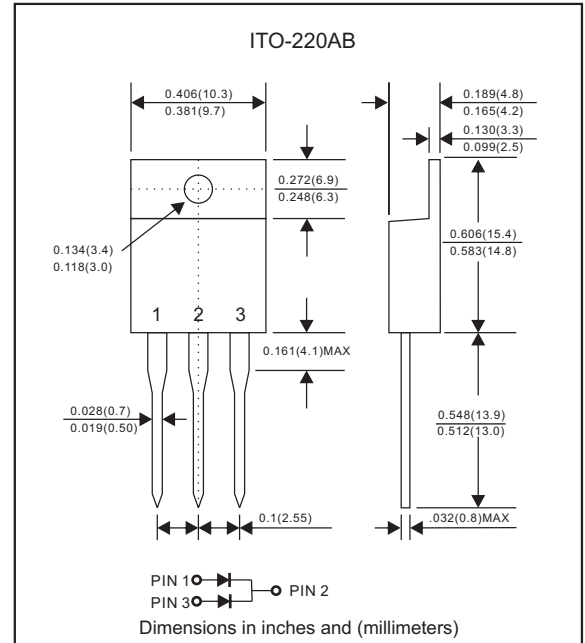

Maximum ratings (AT $T_A=25^\circ\text{C}$ unless otherwise noted)

PARAMETER	SYMBOLS	SB 3020FCT	SB 3040FCT	SB 3045FCT	SB 3050FCT	SB 3060FCT	SB 3080FCT	SB 30100FCT	SB 30150FCT	SB 30200FCT	UNIT
Maximum repetitive peak reverse voltage	V_{RRM}	20	40	45	50	60	80	100	150	200	V
Maximum RMS voltage	V_{RMS}	14	28	31.5	35	42	56	70	105	140	V
Maximum DC blocking voltage	V_{DC}	20	40	45	50	60	80	100	150	200	V
Maximum average forward rectified current	I_O	30									A
Peak forward surge current 8.3ms single half sine-wave (JEDEC method)	I_{FSM}	250									A
Operating junction temperature range	T_J	-55 to +125			-55 to +150						$^\circ\text{C}$
Storage temperature range	T_{STG}	-65 to +175									$^\circ\text{C}$

Electrical Characteristics (AT $T_A=25^\circ\text{C}$ unless otherwise noted)

PARAMETER	SYMBOLS	SB 3020FCT	SB 3040FCT	SB 3045FCT	SB 3050FCT	SB 3060FCT	SB 3080FCT	SB 30100FCT	SB 30150FCT	SB 30200FCT	UNIT	
Maximum forward voltage per leg at $I_F=15\text{A}$	V_F	0.55			0.75		0.85		0.90		v	
Maximum DC reverse current at $T_J=25^\circ\text{C}$ at rated DC blocking voltage at $T_J=100^\circ\text{C}$ per leg	I_R	0.5						50				mA mA

Thermal Characteristics

PARAMETER	SYMBOLS	SB 3020FCT	SB 3040FCT	SB 3045FCT	SB 3050FCT	SB 3060FCT	SB 3080FCT	SB 30100FCT	SB 30150FCT	SB 30200FCT	UNIT
Typical thermal resistance junction to case per leg	$R_{\theta JC}$	2.0									$^\circ\text{C}/\text{W}$

Rating and characteristic curves (SB3020FCT THRU SB30200FCT)

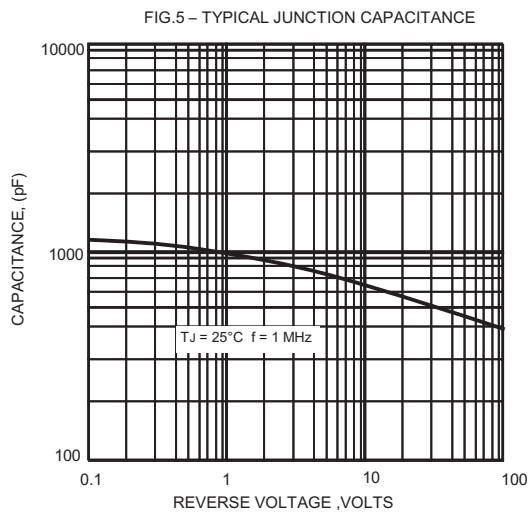
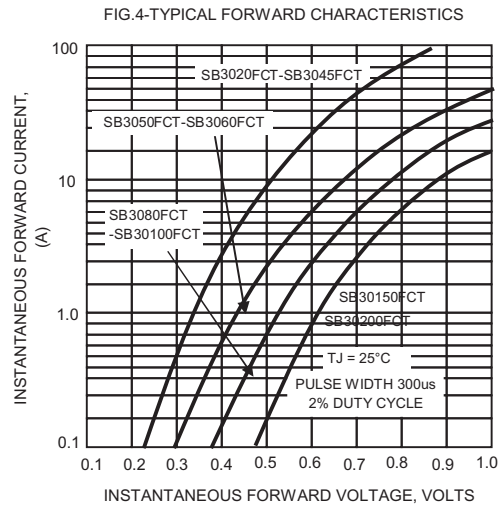
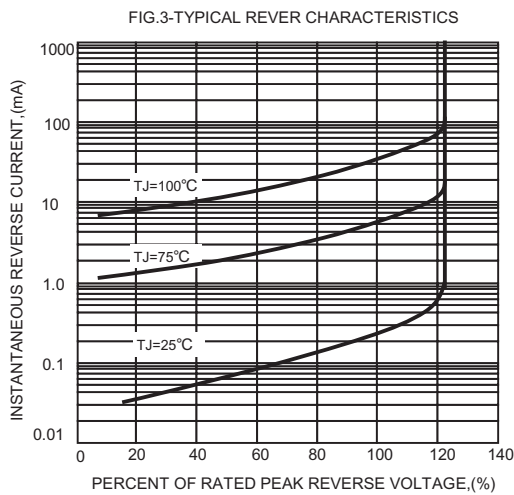
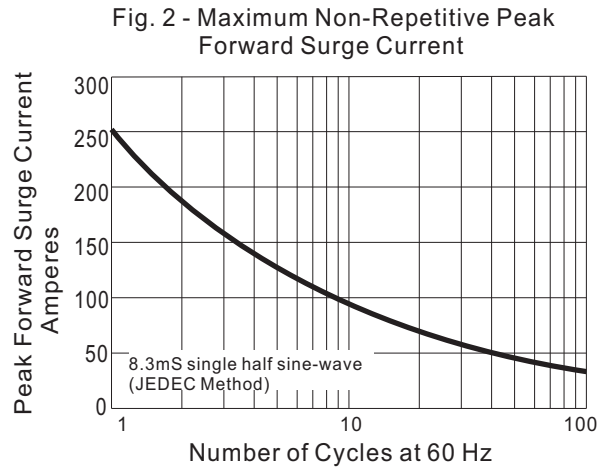
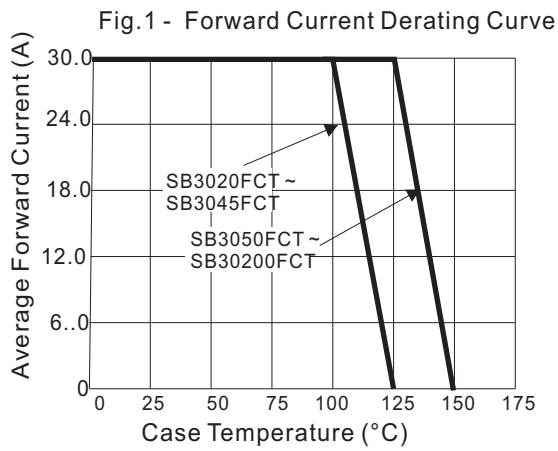

SB3020FCT THRU SB30200FCT

Pinning information

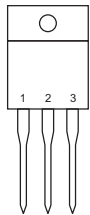
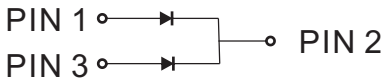
Pin	Simplified outline	Symbol
Pin1 anode Pin2 cathode Pin3 anode		

Marking

Type number	Marking code
SB3020FCT	SB3020FCT
SB3040FCT	SB3040FCT
SB3045FCT	SB3045FCT
SB3050FCT	SB3050FCT
SB3060FCT	SB3060FCT
SB3080FCT	SB3080FCT
SB30100FCT	SB30100FCT
SB30150FCT	SB30150FCT
SB30200FCT	SB30200FCT

Tube packing

PACKAGE	TUBE (pcs)	TUBE SIZE (m/m)	BOX (pcs)	INNER BOX (m/m)	CARTON SIZE (m/m)	CARTON (pcs)	APPROX. GROSS WEIGHT (kg)
ITO-220AB	50	525*32*7.0	1000	555*150*40	580*230*175	5,000	15.0

SB3020FCT THRU SB30200FCT

Suggested thermal profiles for soldering processes

1. Lead free temperature profile wave-soldering

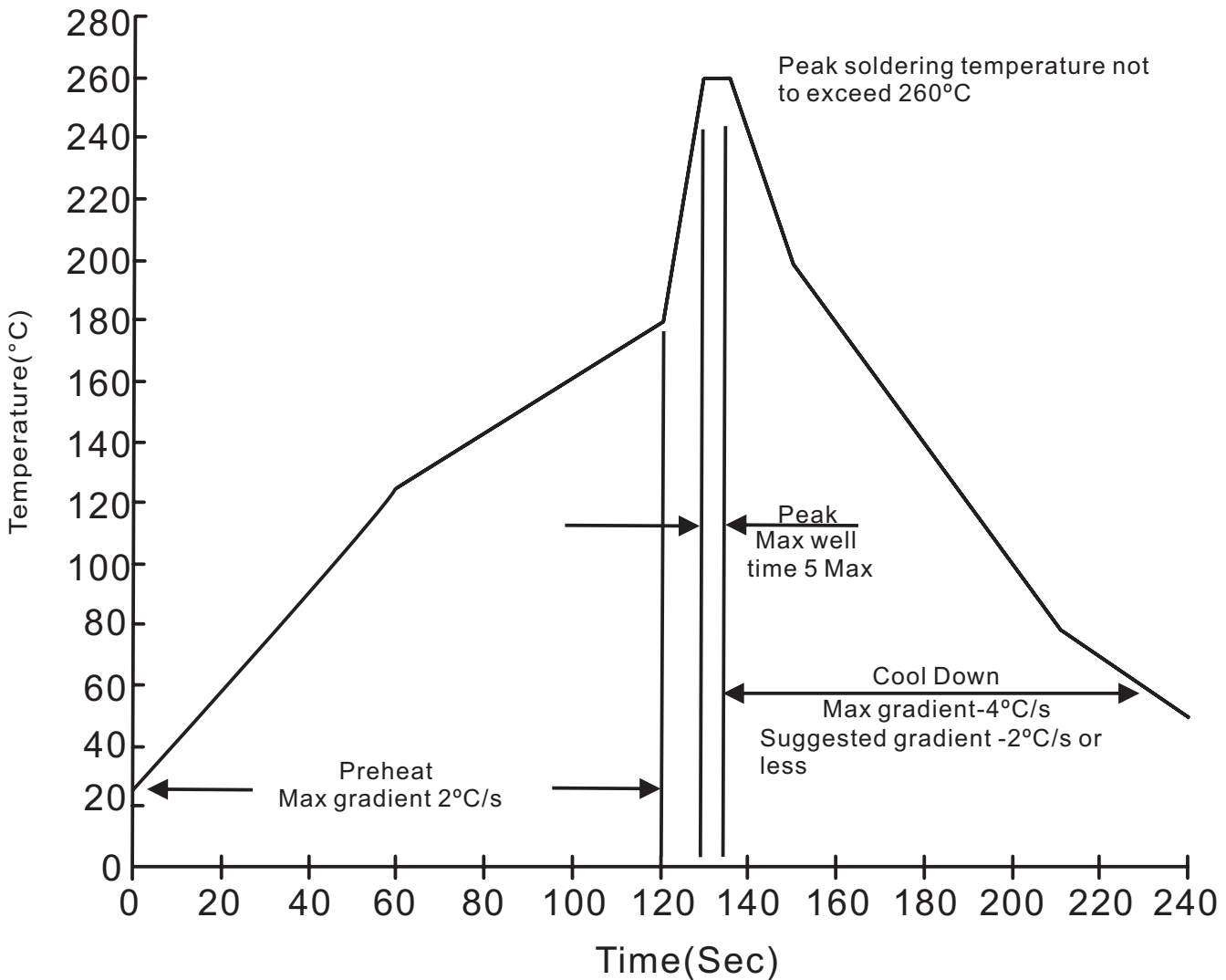

SB3020FCT THRU SB30200FCT**High reliability test capabilities**

Item Test	Conditions	Reference
1. Solder Resistance	at $260\pm 5^{\circ}\text{C}$ for $10\pm 2\text{sec}$. immerse body into solder $1/16''\pm 1/32''$	MIL-STD-750D METHOD-2031
2. Solderability	at $245\pm 5^{\circ}\text{C}$ for 5 sec.	MIL-STD-202F METHOD-208
3. High Temperature Reverse Bias	$V_R=80\%$ rate at $T_J=125^{\circ}\text{C}$ for 168 hrs.	MIL-STD-750D METHOD-1038
4. Forward Operation Life	Rated average rectifier current at $T_A=25^{\circ}\text{C}$ for 500hrs.	MIL-STD-750D METHOD-1027
5. Intermittent Operation Life	$T_A = 25^{\circ}\text{C}$, $I_F = I_O$ On state: power on for 5 min. off state: power off for 5 min. on and off for 500 cycles.	MIL-STD-750D METHOD-1036
6. Pressure Cooker	$15P_{SIG}$ at $T_A=121^{\circ}\text{C}$ for 4 hrs.	JESD22-A102
7. Temperature Cycling	-55°C to $+125^{\circ}\text{C}$ dwelled for 30 min. and transferred for 5min. total 10 cycles.	MIL-STD-750D METHOD-1051
8. Forward Surge	8.3ms single half sine-wave , one surge.	MIL-STD-750D METHOD-4066-2
9. Humidity	at $T_A=85^{\circ}\text{C}$, RH=85% for 1000hrs.	MIL-STD-750D METHOD-1021
10. High Temperature Storage Life	at 175°C for 1000 hrs.	MIL-STD-750D METHOD-1031