



SB8U60

Preliminary

DIODE

8A SCHOTTKY BARRIER RECTIFIER

DESCRIPTION

The UTC **SB8U60** is a 8A schottky barrier rectifier, it uses UTC's advanced technology to provide the customers with sort, fast switching capability and low forward voltage drop, etc.

FEATURES

- * Sort, fast switching capability * High efficiency
- * Low forward voltage drop

SYMBOL

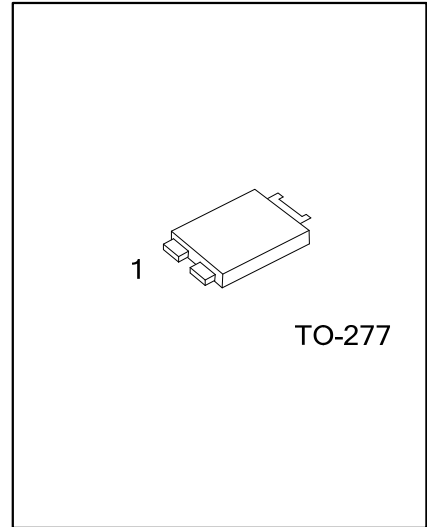
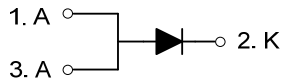

ORDERING INFORMATION

Ordering Number		Package	Pin Assignment			Packing
Lead Free	Halogen Free		1	2	3	
SB8U60L-T27-R	SB8U60G-T27-R	TO-277	A	K	A	Tape Reel

Note: Pin Assignment: A: Anode K: Common Cathode

<p>SB8U60L-T27-R</p> <p>(1)Packing Type</p> <p>(2)Package Type</p> <p>(3)Green Package</p>	<p>(1) R: Tape Reel</p> <p>(2) T27: TO-227</p> <p>(3) L: Lead Free, G: Halogen Free and Lead Free</p>
--	---

MARKING

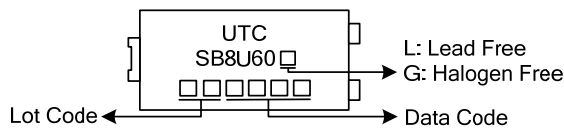

■ ABSOLUTE MAXIMUM RATINGS ($T_A=25^{\circ}\text{C}$ unless otherwise specified.)

Single phase, half wave, 60Hz, resistive or inductive load. For capacitance load, derate current by 20%.

PARAMETER	SYMBOL	RATINGS	UNIT
Peak Repetitive Reverse Voltage	V_{RRM}	60	V
Working Peak Reverse Voltage	V_{RWM}	60	V
DC Blocking Voltage	V_{RM}	60	V
Average Rectified Output Current	I_O	8	A
Non-Repetitive Peak Forward Surge Current 8.3ms Single Half Sine-Wave Superimposed on Rated Load	I_{FSM}	280	A
Operating Junction Temperature	T_J	-65~ +150	$^{\circ}\text{C}$
Storage Temperature	T_{STG}	-65~ +150	$^{\circ}\text{C}$

Note: Absolute maximum ratings are those values beyond which the device could be permanently damaged. Absolute maximum ratings are stress ratings only and functional device operation is not implied.

■ THERMAL CHARACTERISTICS

PARAMETER	SYMBOL	RATINGS	UNIT
Junction to Ambient	θ_{JA}	60	$^{\circ}\text{C}/\text{W}$
Junction to Case (Note)	θ_{JC}	13	$^{\circ}\text{C}/\text{W}$

Note: Polyimide PCB, 2 oz. Copper.

■ ELECTRICAL CHARACTERISTICS ($T_A=25^{\circ}\text{C}$ unless otherwise specified.)

PARAMETER	SYMBOL	TEST CONDITIONS	MIN	TYP	MAX	UNIT
Forward Voltage Drop	V_F	$I_F=1.0\text{A}, T_J=25^{\circ}\text{C}$		0.30	0.35	V
		$I_F=8\text{A}, T_J=25^{\circ}\text{C}$		0.46	0.53	V
		$I_F=8\text{A}, T_J=125^{\circ}\text{C}$			0.5	V
Reverse Current (Note 2)	I_R	$V_R=60\text{V}, T_J=25^{\circ}\text{C}$		0.12	0.6	mA
		$V_R=60\text{V}, T_J=125^{\circ}\text{C}$			100	mA

Notes: 1. Theoretical θ_{JS} calculated from the top center of the die straight down to the PCB cathode tab solder junction.

2. Short duration pulse test used to minimize self-heating effect.

UTC assumes no responsibility for equipment failures that result from using products at values that exceed, even momentarily, rated values (such as maximum ratings, operating condition ranges, or other parameters) listed in products specifications of any and all UTC products described or contained herein. UTC products are not designed for use in life support appliances, devices or systems where malfunction of these products can be reasonably expected to result in personal injury. Reproduction in whole or in part is prohibited without the prior written consent of the copyright owner. The information presented in this document does not form part of any quotation or contract, is believed to be accurate and reliable and may be changed without notice.