



Schottky Barrier Rectifiers

SBLF2030CT---SBLF20100CT

FEATURES

- Metal-Semiconductor Junction with Guard Ring.
- Epitaxial Construction.
- Low Forward Voltage Drop, Low Switching Losses.
- High Surge Capability.
- For use in low voltage, high frequency
Inverters, free wheeling, and polarity protection applications.
- The Plastic Material Carries U/L Recognition 94V-0.



Lead-free

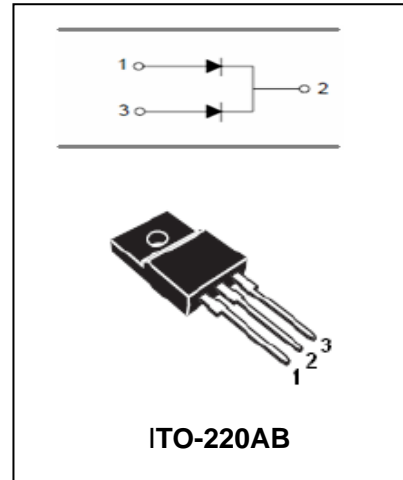

MAXIMUM RATING operating temperature range applies unless otherwise specified

Symbol	Parameter	SBLF 2030 CT	SBLF 2035 CT	SBLF 2040 CT	SBLF 2045 CT	SBLF 2050 CT	SBLF 2060 CT	SBLF 2080 CT	SBLF 20100 CT	Unit
V_{RRM}	Recurrent Peak Reverse Voltage	30	35	40	45	50	60	80	100	V
V_{RMS}	RMS Voltage	21	25	28	32	35	42	56	70	V
V_{DC}	DC Blocking Voltage	30	35	40	45	50	60	80	100	V
$I_{F(AV)}$	Average Forward Total Device Rectified Current @ $T_A=100^{\circ}C$	20								A
I_{FSM}	Peak Forward Surge Current 8.3ms Single Half- Sine-wave Superimposed On rated load	250								A
$R_{\theta JC}$	Typical Thermal Resistance(Note1)	1.5								$^{\circ}C/W$
$T_j T_{stg}$	Operating Junction and Storage Temperature Range	-55 to +150								$^{\circ}C$

Note1. Thermal Resistance Junction to Case.



Schottky Barrier Rectifiers

SBLF2030CT---SBLF20100CT

ELECTRICAL CHARACTERISTICS @ Ta=25°C unless otherwise specified

Parameter	Symbol	Test conditions	SBLF2030CT- SBLF2045CT	SBLF2050CT- SBLF2060CT	SBLF2080CT- SBLF20100CT	UNIT
			MAX			
Reverse Current	I_R	$V_R=V_{RRM}, T_A=25^\circ C$ $V_R=V_{RRM}, T_A=100^\circ C$	1.0 50			mA
Forward Voltage	V_F	$I_F=10A$	0.60	0.70	0.85	V

TYPICAL CHARACTERISTICS @ Ta=25°C unless otherwise specified

FIG.1 -- PEAK FORWARD SURGE CURRENT

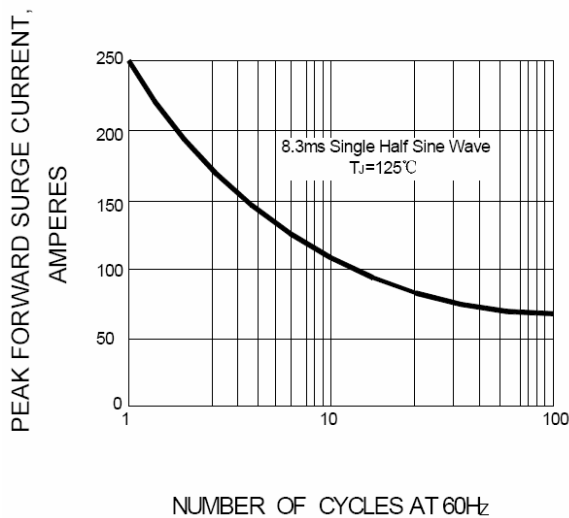

FIG.2 -- FORWARD DERATING CURVE

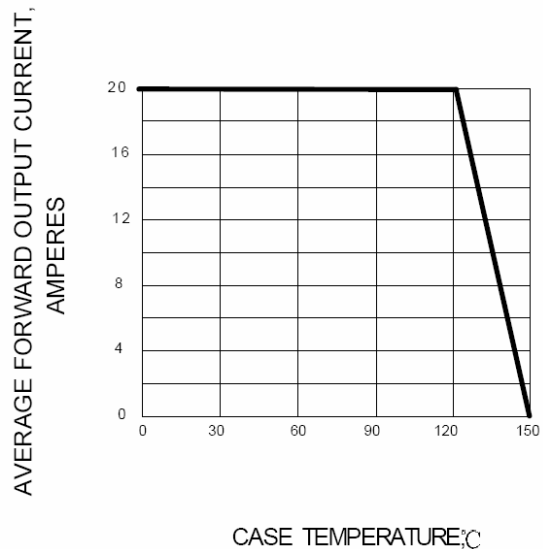

FIG.3 -- TYPICAL FORWARD CHARACTERISTIC

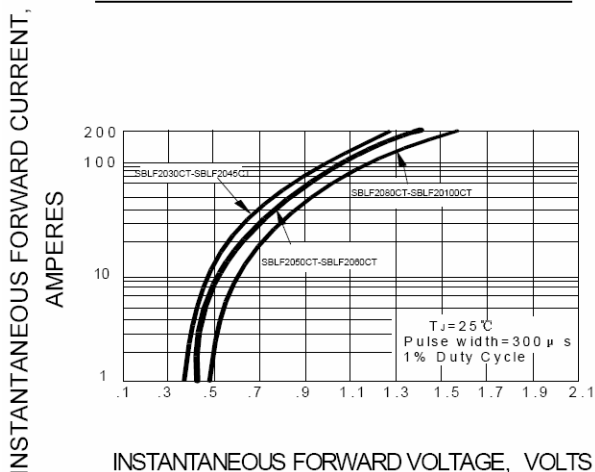
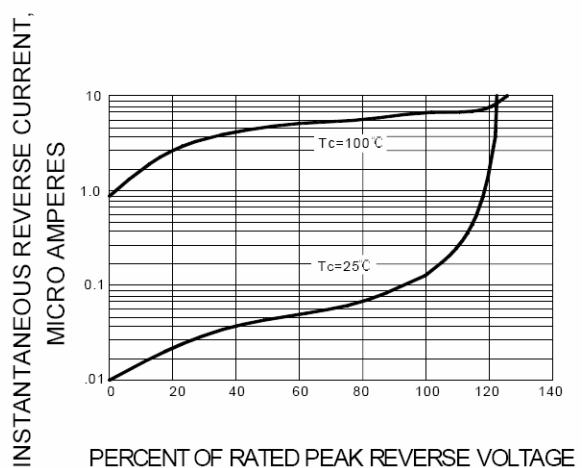

FIG.4 -- TYPICAL REVERSE CHARACTERISTIC





Schottky Barrier Rectifiers

SBLF2030CT---SBLF20100CT

PACKAGE OUTLINE

Plastic surface mounted package

ITO-220AB

