

High Voltage Fast-Switching NPN Power Transistor

Features

- Very High Switching Speed
- High Voltage Capability
- Wide Reverse Bias SOA

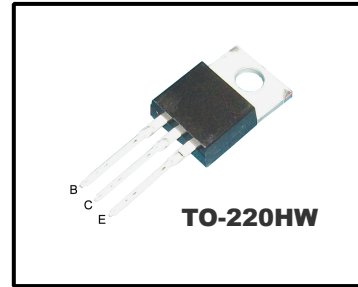
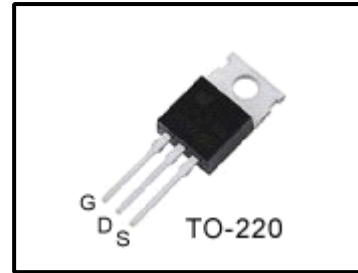

General Description

This Device is designed for high voltage, High speed switching characteristics required such as lighting system, switching mode power supply.

Absolute Maximum Ratings

Symbol	Parameter	Test Conditions	Value	Units
V_{CES}	Collector-Emitter Voltage	$V_{BE} = 0$	700	V
V_{CEO}	Collector-Emitter Voltage	$I_B = 0$	400	V
V_{EBO}	Emitter-Base Voltage	$I_C = 0$	9.0	V
I_C	Collector Current		4.0	A
I_{CP}	Collector pulse Current		8.0	A
I_B	Base Current		2.0	A
I_{BM}	Base Peak Current	$t_P = 5ms$	4.0	A
P_C	Total Dissipation at $T_c^* = 25^\circ C$		75	W
	Total Dissipation at $T_a^* = 25^\circ C$		2.0	
T_J	Operation Junction Temperature		- 40 ~ 150	$^\circ C$
T_{STG}	Storage Temperature		- 40 ~ 150	$^\circ C$

T_c : Case temperature (good cooling)

T_a : Ambient temperature (without heat sink)

Thermal Characteristics

Symbol	Parameter	Value	Units
$R_{\theta Jc}$	Thermal Resistance Junction to Case	1.67	$^\circ C/W$
$R_{\theta JA}$	Thermal Resistance Junction to Ambient	62.5	$^\circ C/W$

Ordering Information

Order codes	Package	Marking	Halogen Free	Packaging
SBP13005-O	TO220C	P13005-O	NO	Tube
SBP13005-O-HW	TO220HW	P13005-O	NO	Tube

Electrical Characteristics ($T_C=25^{\circ}\text{C}$ unless otherwise noted)

Symbol	Parameter	Test Conditions	Value			Units
			Min	Typ	Max	
$V_{CEO(sus)}$	Collector-Emitter Breakdown Voltage	$I_C=10\text{mA}, I_B=0$	400	-	-	V
$V_{CE(sat)}$	Collector-Emitter Saturation Voltage	$I_C=1.0\text{A}, I_B=0.2\text{A}$ $I_C=2.0\text{A}, I_B=0.5\text{A}$ $I_C=4\text{A}, I_B=1.0\text{A}$	-	-	0.3 0.5 1.0	V
$V_{BE(sat)}$	Base-Emitter Saturation Voltage	$I_C=1.0\text{A}, I_B=0.2\text{A}$ $I_C=2.0\text{A}, I_B=0.5\text{A}$	-	-	1.2 1.6	V
I_{CBO}	Collector-Base Cutoff Current ($V_{be}=-1.5\text{V}$)	$V_{cb}=700\text{V}$ $V_{cb}=700\text{V}, T_C=100^{\circ}\text{C}$	-	-	1.0 5.0	mA
h_{FE}	DC Current Gain	$V_{ce}=2\text{V}, I_C=1.0\text{A}$ $V_{ce}=2\text{V}, I_C=2.0\text{A}$	10 8	- -	40 40	
t_s t_f	Resistive Load Storage Time Fall Time	$V_{CC}=125\text{V}, I_C=2.0\text{A}$ $I_{B1}=0.4\text{A}, I_{B2}=-1.0\text{A}$ $T_p=25\mu\text{s}$	-	2.5 0.15	4.0 0.4	μs
t_s t_f	Inductive Load Storage Time Fall Time	$V_{CC}=15\text{V}, I_C=1\text{A}$ $I_{B1}=0.4\text{A}, I_{B2}=-0.1\text{A}$ $L=0.35\text{mH}, V_{clamp}=300\text{V}$	- -	1.2 0.12	4.0 0.3	μs
t_s t_f	Inductive Load Storage Time Fall Time	$V_{CC}=15\text{V}, I_C=1\text{A}$ $I_{B1}=0.4\text{A}, I_{B2}=-1.0\text{A}$ $L=0.35\text{mH}, V_{clamp}=300\text{V}$ $T_C=100^{\circ}\text{C}$	- -	1.2 0.08	3.0 0.4	μs

Note:

Pulse Test : Pulse width 300, Duty cycle 2%

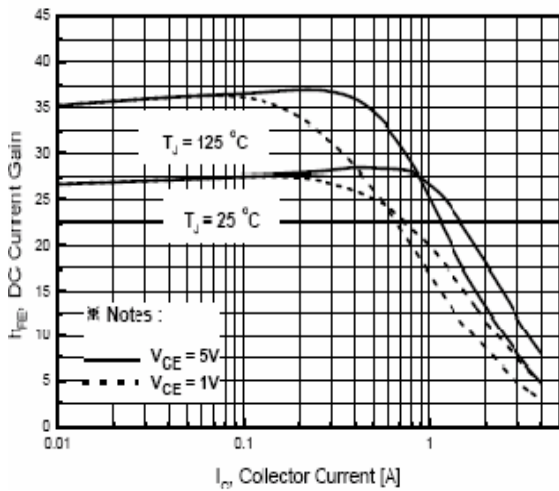

Fig. 1 DC Current Gain

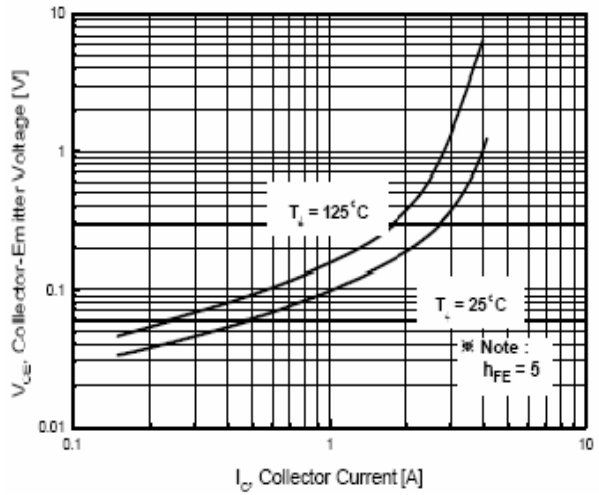

Fig. 2 Collector-Emitter Saturation Voltage

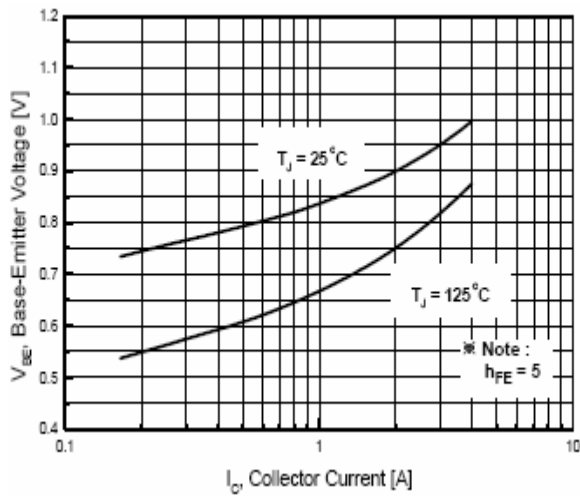

Fig. 3 Base-Emitter Saturation Voltage

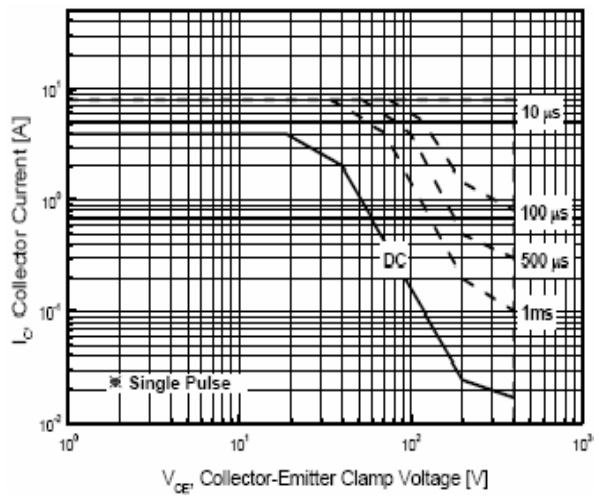

Fig. 4 Safe Operation Area

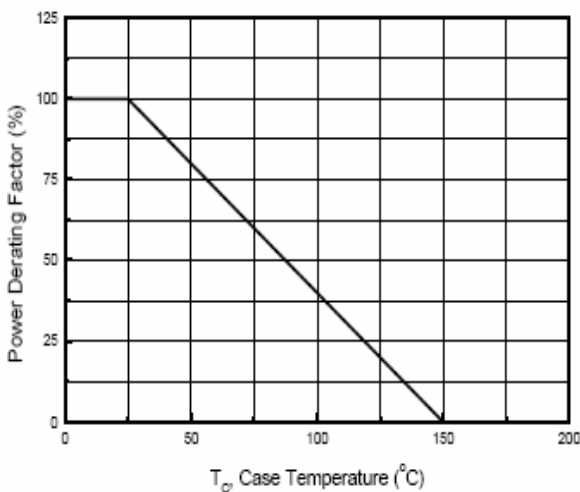

Fig. 5 Power Derating

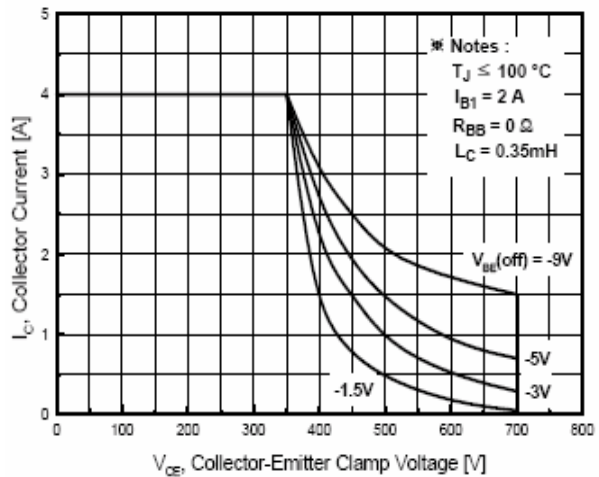
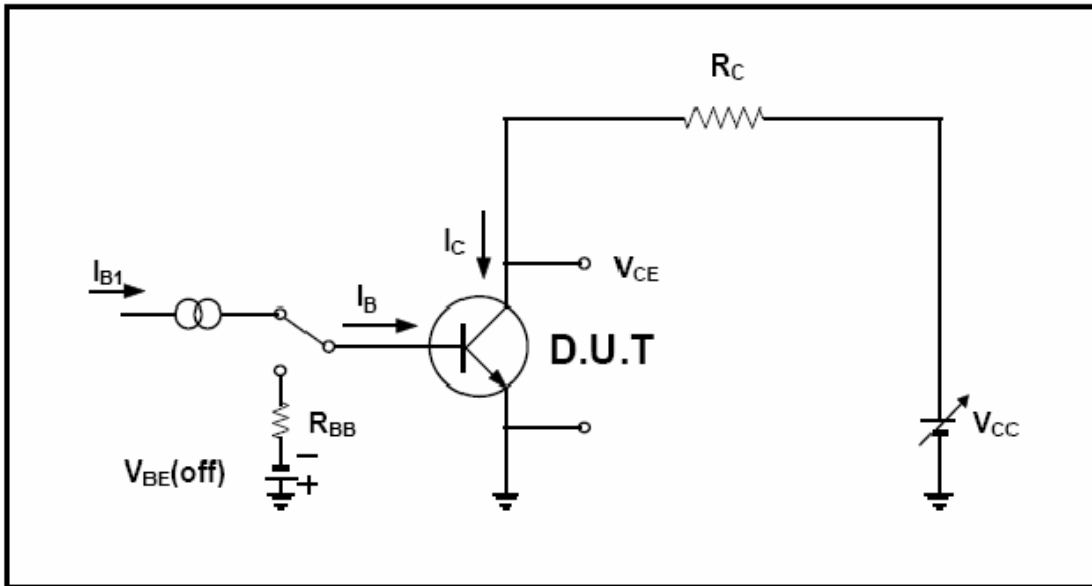
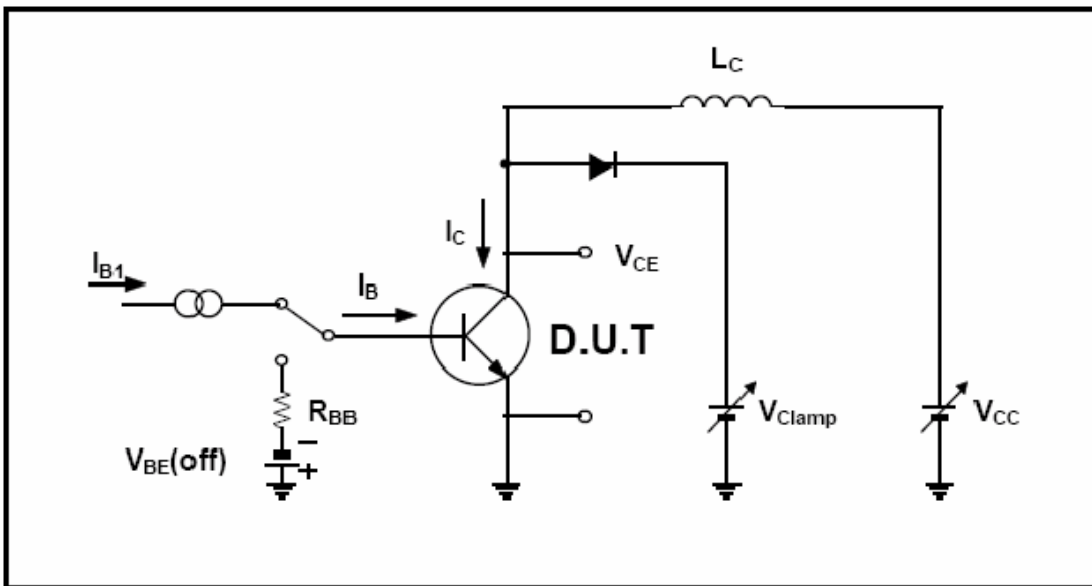

Fig. 6 Reverse Biased Safe Operation Area

Resistive Load Switching Test Circuit



Inductive Load Switching & RBSOA Test Circuit



TO-220C Package Dimension

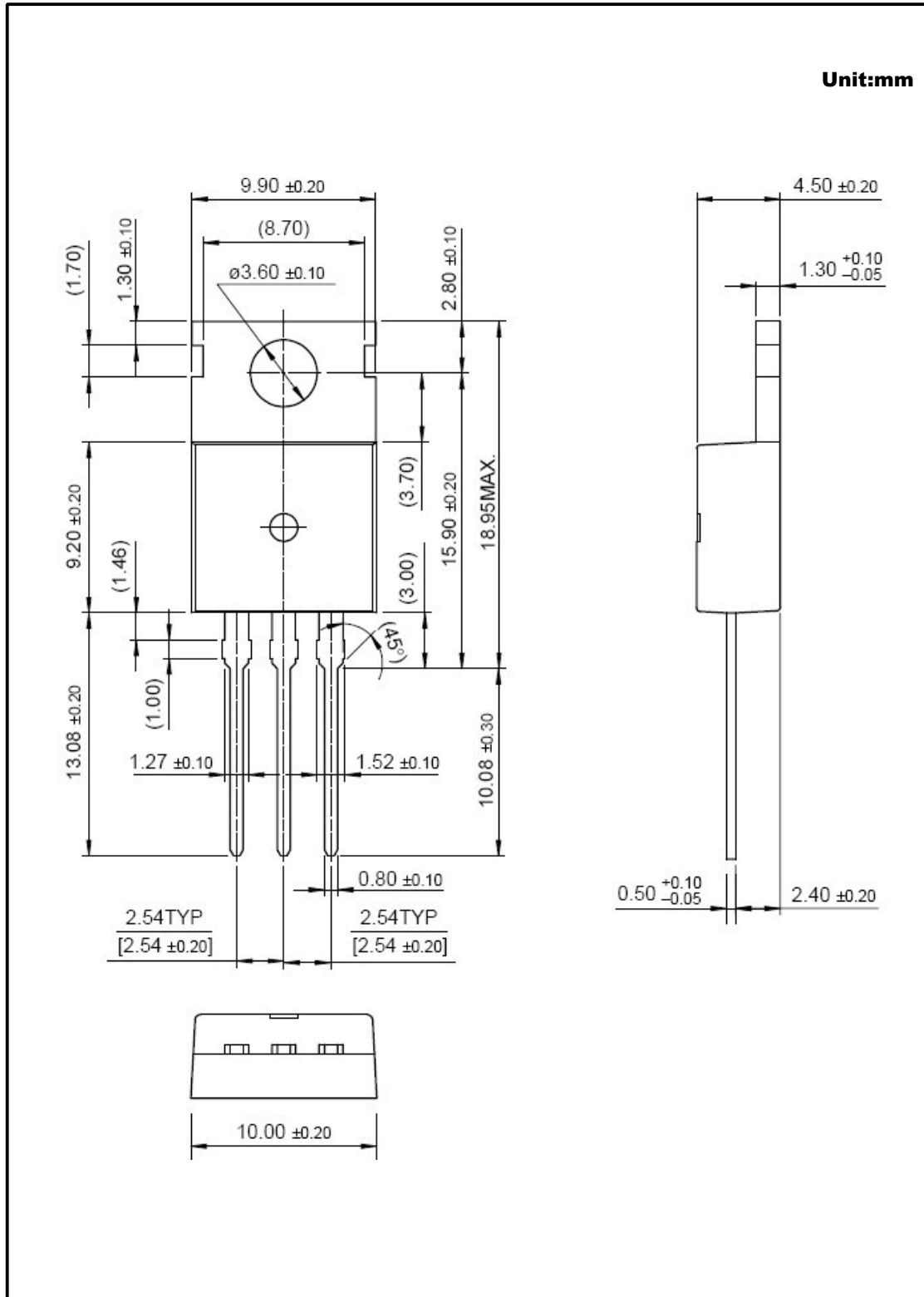

TO-220HW Package Dimension

Unit:mm

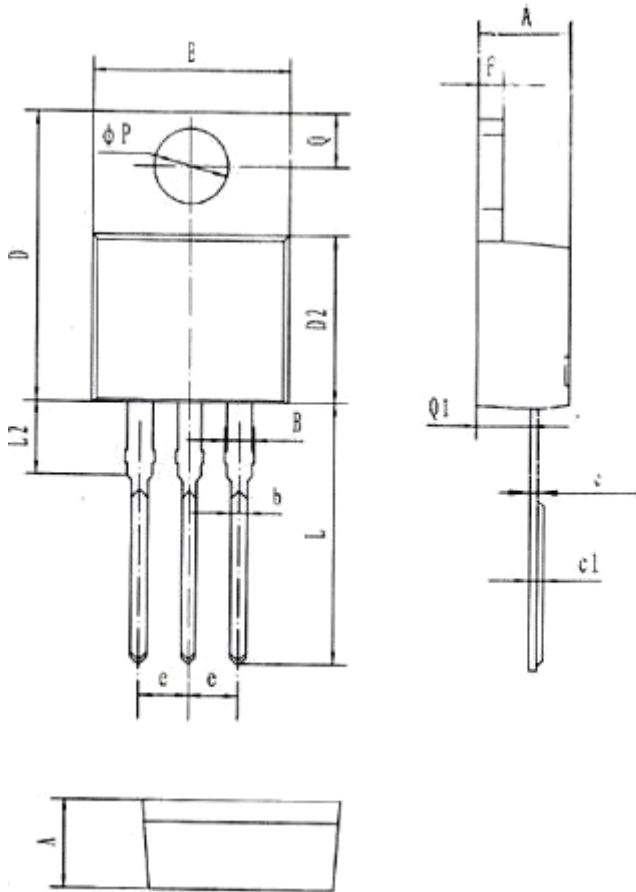

符号 symbol	MIN	MAX
A	4.40	4.80
B	1.10	1.40
b	0.70	0.95
c	0.28	0.48
c1	0.32	0.52
D	14.45	16.00
D2	8.20	9.20
E	9.60	10.40
e	2.39	2.69
F	1.20	1.35
L	13.05	14.05
L2	3.70	3.90
Q	2.40	3.00
Q1	2.20	2.90
P	3.50	4.00