

Recordable DVD Home Theater System

Operating Instructions

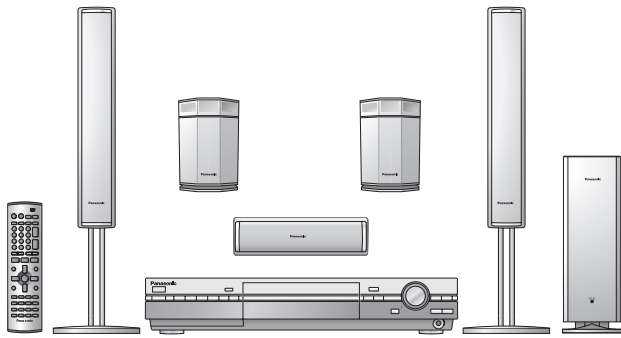

Operations Guide

Before using this product, perform setup and connections after carefully reading the Setup Guide.

Model No. **SC-HT1000**

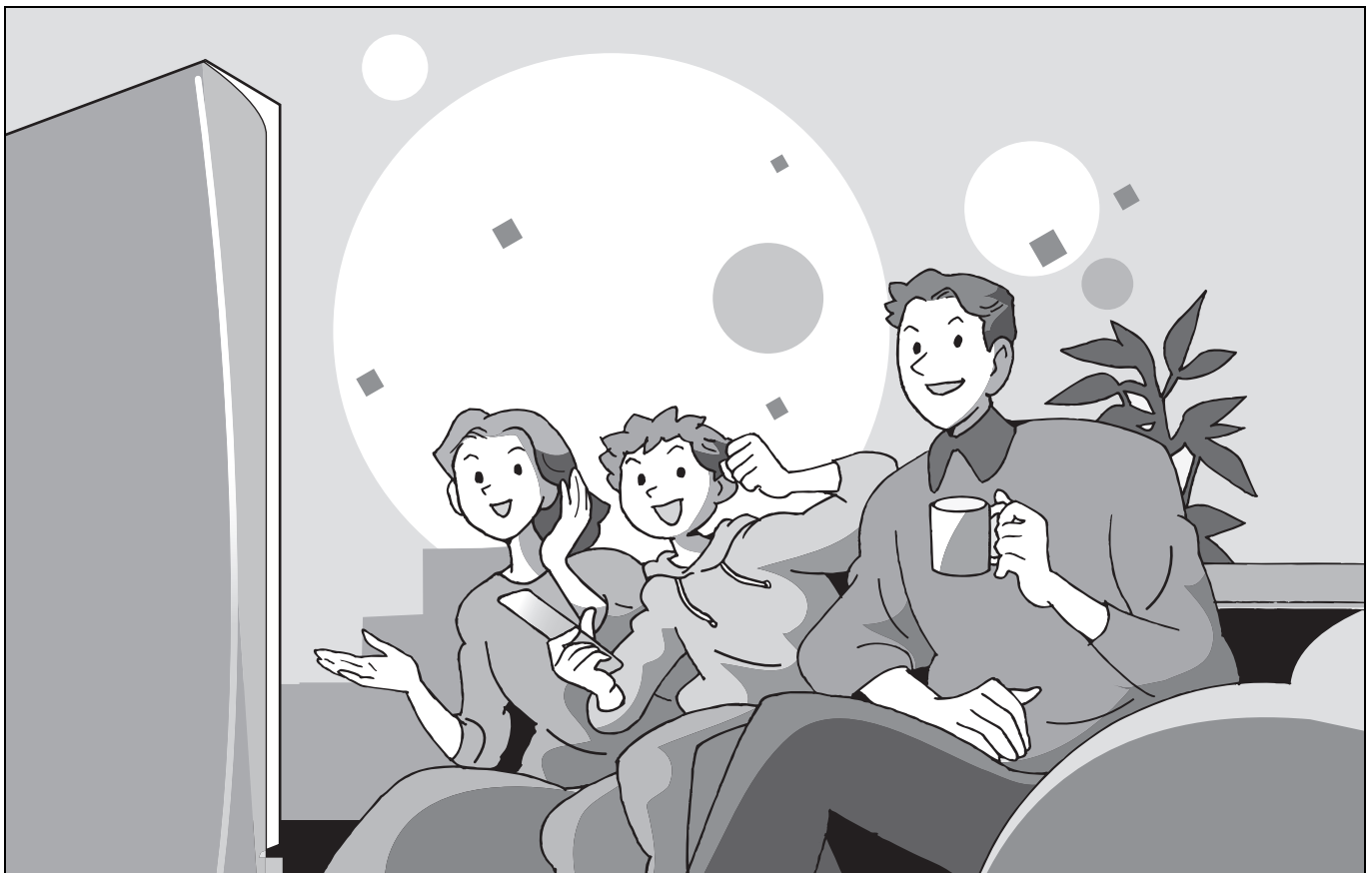

Dear customer

Thank you for purchasing this product. For optimum performance and safety, please read these instructions carefully.

Before connecting, operating or adjusting this product, please read these instructions completely. Please keep this manual for future reference.



Region number supported by this unit

Region numbers are allocated to DVD players and software according to where they are sold.

- The region number of this unit is "1".
- The unit will play DVDs marked with labels containing "1" or "ALL".

Example:



For U.S.A. only

The warranty can be found on page 54.

For Canada only

The warranty can be found on page 55.









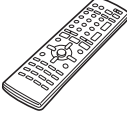

Accessories

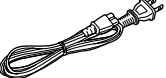

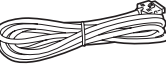
Please check and identify the supplied accessories. Use numbers indicated in parentheses when asking for replacement parts.

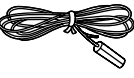
Only for U.S.A.: To order accessories contact 1-800-332-5368 or the website (<http://www.panasonic.com>).

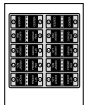
Only for Canada: To order accessories, call the dealer from whom you have made your purchase.

- 1 Remote control (EUR7624KP0) 
- 2 Batteries for remote control 
- 2 AC power supply cords (RJA0065-1D) 
- 1 Video cable (RJL1P016B15A) 
- 1 75 Ω coaxial cable (K1TXAAA00001) 
- 1 System cable (K1HA25HA0001) 
- 1 AM loop antenna (N1DAAAA00002) 
- 1 FM indoor antenna (RSA0007-L) 
- 3 Speaker cables
1×4 m (13 foot) cable (REE1203A-J)
2×10 m (33 foot) cables (REE1203C-J) 
- 1D VD-RAM disc 
- 1 Sheet of speaker-cable stickers 
- 1 Antenna plug (K2RC021B0001) 
- 8 Front speaker screws
4 large screws (XSS6+14FZ)
4 small screws (XSN5+10FN) 

Note
The included AC power supply cord is for use with this unit only. Do not use it with other equipment.

(U.S.A. only)
Product Registration Card
Please complete and return the included product registration card, or register via the Internet at: <http://www.prodreg.com/panasonic/>

System	SC-HT1000
Main unit	SA-HT1000
Front speakers	SB-PF1000
Center speaker	SB-PC1000
Surround speakers	SB-PS1000
Active subwoofer	SB-WA351

Operations in these instructions are described mainly with the remote control, but you can do the operations on the main unit if the controls are the same.

The remote control

Batteries

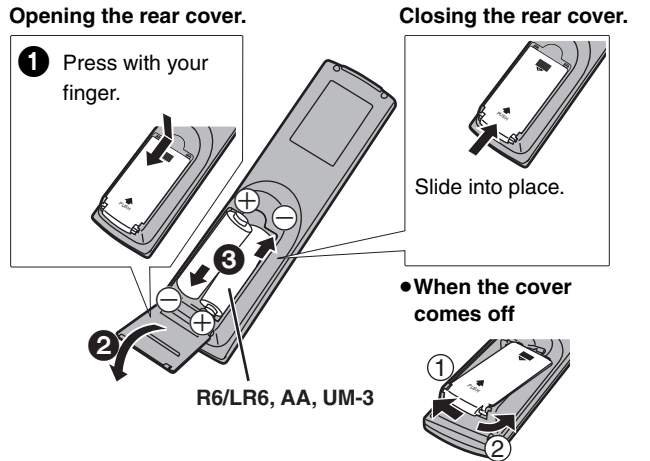

- Insert so the poles (+ and -) match those in the remote control.
- Do not use rechargeable type batteries.

- Do not:**
- Mix old and new batteries.
 - Use different types at the same time.
 - Heat or expose to flame.
 - Take apart or short circuit.
 - Attempt to recharge alkaline or manganese batteries.
 - Use batteries if the covering has been peeled off.
- Mishandling of batteries can cause electrolyte leakage which can damage items the fluid contacts and may cause a fire.

Remove if the remote control is not going to be used for a long period of time. Store in a cool, dark place.

Note
If you cannot operate the unit or television using the remote control after changing the batteries, please re-enter the codes (television → page 11, main unit → page 42).

Use
Aim at the sensor, avoiding obstacles, at a maximum range of 7 m (23 feet) directly in front of the unit.

Table of contents

INTRO	Accessories 2	Disc information 8
	The remote control 2	Discs you can use for recording and play 8
	IMPORTANT SAFETY INSTRUCTIONS 5	Play-only discs 8
	Features 5	STEP 1 Plug-in Auto Tuning 9
Control reference guide 6	STEP 2 VCR Plus+ guide channel settings 10	
Remote control and subwoofer 6	STEP 3 Set up to match your television 11	
Main unit and display 7	Television operation 11	
RECORDING	Recording television programs 12	Timer recording 14
	Inserting discs 12	Using VCR Plus+ codes to make timer recordings 14
	Recording modes and approximate recording times in hours 12	Manually programming timer recordings 15
	Recording the best quality pictures within the set amount of time—Flexible Recording 13	Check programs 16
	Selecting the audio recording mode 13	Change or delete the program 16
	Watching the television while recording 13	Playing while you are recording 17
	Specify a time to stop recording 13	Playing from the beginning of the program while you are recording—Chasing Play 17
	Recording from a video cassette recorder 13	Simultaneous rec and play 17
		Reviewing the recorded images while recording—Time Slip 17
		Starting play from a selected item 19
PLAYING	Playing discs 18	Selecting an amount of time to skip—Time Slip 20
	Operations during play 18	Quick View 20
	Using the Direct Navigator 19	Skipping a minute forward—CM Skip 20
	Changing audio during play 19	Using menus to play MP3 discs 21
	Position Memory 19	
When a menu appears on the television 19		
ON-SCREEN DISPLAYS	Using on-screen menus 22	On-screen displays 24
	Common procedures 22	Changing the information displayed 24
	Disc menu 22	Display examples 24
	Audio menu 22	Using the FUNCTIONS window 25
	Play menu 23	
Video menu 23		
EDITING	Entering text 26	Editing programs 30
	Creating and playing play lists 27	Erase Program 30
	Creating play list 27	Enter Title 30
	Playing play lists 27	Properties 30
	Playing scenes and editing play lists 28	Protection 30
	Play Scenes 28	Shorten Segment 31
	PL Copy 28	Divide Program 31
	PL Erase 28	Disc setting 32
	Enter Title 28	Enter Title 32
	Properties 28	Disc Protection 32
Edit Scenes 29	Erase all programs 32	
	Format 33	
	Finalize 33	
RADIO & SOUND	The radio 34	Sound Field Control 36
	Manual tuning 34	Center Focus 36
	Preset tuning 34	Virtual Rear Surround 37
	Optional FM antenna connection 35	Multi Rear Surround 37
	Sound 36	Seat position 37
Dolby Digital and DTS 36	Adjusting the bass 37	
Dolby Pro Logic II 36	Speaker level adjustments 37	
SETTINGS	Changing the unit's settings 38	Other channel settings 41
	Summary of settings 38	Changing the remote control code 42
	Common procedures 40	Changing the delay time (Speaker) 42
	Antenna System and Auto Channel Setting 40	Clock settings 43
INFO	Optional connections 44	Glossary 51
	Connecting other video equipment 44	Specifications 52
	Connecting a cable TV box/satellite receiver 44	Disc handling 53
	Receiving digital audio using the optical connection 45	Maintenance 53
	Connecting other audio equipment 45	Product Service 53
	Other antenna connections 46	Limited Warranty (ONLY FOR U.S.A.) 54
	Other antenna connections to the unit 46	Limited Warranty (ONLY FOR CANADA) 55
	Other antenna connections from the unit to the television 46	Index 56
Error messages 47		
Troubleshooting guide 48		

CAUTION!

DO NOT INSTALL OR PLACE THIS UNIT IN A BOOKCASE, BUILT-IN CABINET OR IN ANOTHER CONFINED SPACE. ENSURE THE UNIT IS WELL VENTILATED. TO PREVENT RISK OF ELECTRIC SHOCK OR FIRE HAZARD DUE TO OVERHEATING, ENSURE THAT CURTAINS AND ANY OTHER MATERIALS DO NOT OBSTRUCT THE VENTILATION VENTS.

CAUTION:

TO PREVENT ELECTRIC SHOCK MATCH WIDE BLADE OF PLUG TO WIDE SLOT, FULLY INSERT.

WARNING:

TO REDUCE THE RISK OF FIRE, ELECTRIC SHOCK OR PRODUCT DAMAGE, DO NOT EXPOSE THIS APPARATUS TO RAIN, MOISTURE, DRIPPING OR SPLASHING AND THAT NO OBJECTS FILLED WITH LIQUIDS, SUCH AS VASES, SHALL BE PLACED ON THE APPARATUS.

CAUTION!

THIS PRODUCT UTILIZES A LASER. USE OF CONTROLS OR ADJUSTMENTS OR PERFORMANCE OF PROCEDURES OTHER THAN THOSE SPECIFIED HEREIN MAY RESULT IN HAZARDOUS RADIATION EXPOSURE. DO NOT OPEN COVERS AND DO NOT REPAIR YOURSELF. REFER SERVICING TO QUALIFIED PERSONNEL.

THE FOLLOWING APPLIES ONLY IN THE U.S.A.

Note to CATV system installer:

This reminder is provided to call the CATV system installer's attention to Article 820-40 of the NEC that provides guidelines for proper grounding and, in particular, specifies that the cable ground shall be connected to the grounding system of the building, as close to the point of cable entry as practical.

DANGER	- VISIBLE AND INVISIBLE LASER RADIATION WHEN OPEN. AVOID DIRECT EXPOSURE TO BEAM. (FDA 21 CFR)
CAUTION	- VISIBLE AND INVISIBLE LASER RADIATION WHEN OPEN. AVOID EXPOSURE TO BEAM. (IEC60825-1)
ATTENTION	- RAYONNEMENT LASER VISIBLE ET INVISIBLE EN CAS D'OUVERTURE. EXPOSITION DANGEREUSE AU FASCIAU.
ADVARSEL	- SYNLIG OG USYNLIG LASERSTRÅLING VED ÅBNING. UNNGÅ UDSÆTTELSE FOR STRÅLING.
VARO!	- AVATTAESSA OLET ALTTIINA NÄKYVÄÄ JA NÄKYMÄTÖN LASERSÄTELYLLÄ. ÄLÄ KÄTSO SÄTEESEEN.
WARNING	- SYNLIG OCH OSYNLIG LASERSTRÅLNING NÄR DENNA DEL ÄR ÖPPNAD. BESTRÄKTA EJ STRÅLEN.
ADVARSEL	- SYNLIG OG USYNLIG LASERSTRÅLING NÄR DEKSEL ÅPNES. UNNGÅ EKSPONERING FOR STRÅLEN.
VORSICHT	- SICHTBARE UND UNSICHTBARE LASERSTRÄHLUNG, WENN ABDECKUNG GEÖFFNET. NICHT DEM STRAHL AUSSETZEN.
注意	- 打开时有可见及不可见激光辐射。避免激光束照射。
注意	- ここを開くと可視及び不可視のレーザー光が出ます。ビームを直接見たり、触れたりしないでください。 RQLS0233

(Inside of product)

THE FOLLOWING APPLIES ONLY IN THE U.S.A.

FCC Note:

This equipment has been tested and found to comply with the limits for a Class B digital device, pursuant to Part 15 of the FCC Rules. These limits are designed to provide reasonable protection against harmful interference in a residential installation. This equipment generates, uses, and can radiate radio frequency energy and, if not installed and used in accordance with the instructions, may cause harmful interference to radio communications. However, there is no guarantee that interference will not occur in a particular installation. If this equipment does cause harmful interference to radio or television reception, which can be determined by turning the equipment off and on, the user is encouraged to try to correct the interference by one or more of the following measures:

- Reorient or relocate the receiving antenna.
- Increase the separation between the equipment and receiver.
- Connect the equipment into an outlet on a circuit different from that to which the receiver is connected.
- Consult the dealer or an experienced radio/TV technician for help.

FCC Caution: To assure continued compliance, follow the attached installation instructions and use only shielded interface cables when connecting to peripheral devices.

Any changes or modifications not expressly approved by the party responsible for compliance could void the user's authority to operate this equipment.

This device complies with Part 15 of the FCC Rules. Operation is subject to the following two conditions: (1) This device may not cause harmful interference, and (2) this device must accept any interference received, including interference that may cause undesired operation.



CAUTION
RISK OF ELECTRIC SHOCK
DO NOT OPEN



CAUTION: TO REDUCE THE RISK OF ELECTRIC SHOCK, DO NOT REMOVE SCREWS. NO USER-SERVICEABLE PARTS INSIDE. REFER SERVICING TO QUALIFIED SERVICE PERSONNEL.



The lightning flash with arrowhead symbol, within an equilateral triangle, is intended to alert the user to the presence of uninsulated "dangerous voltage" within the product's enclosure that may be of sufficient magnitude to constitute a risk of electric shock to persons.



The exclamation point within an equilateral triangle is intended to alert the user to the presence of important operating and maintenance (servicing) instructions in the literature accompanying the appliance.

Before moving the unit, ensure the disc tray is empty. Failure to do so will risk severely damaging the disc and the unit.

The model number and serial number of this product can be found on either the back or the bottom of the unit. Please note them in the space provided below and keep for future reference.

MODEL NUMBER _____ SC-HT1000 _____
SERIAL NUMBER _____

User memo:

DATE OF PURCHASE _____
DEALER NAME _____
DEALER ADDRESS _____
TELEPHONE NUMBER _____

IMPORTANT SAFETY INSTRUCTIONS

Read these operating instructions carefully before using the unit. Follow the safety instructions on the unit and the applicable safety instructions listed below. Keep these operating instructions handy for future reference.

- 1) Read these instructions.
- 2) Keep these instructions.
- 3) Heed all warnings.
- 4) Follow all instructions.
- 5) Do not use this apparatus near water.
- 6) Clean only with dry cloth.
- 7) Do not block any ventilation openings. Install in accordance with the manufacturer's instructions.
- 8) Do not install near any heat sources such as radiators, heat registers, stoves, or other apparatus (including amplifiers) that produce heat.
- 9) Do not defeat the safety purpose of the polarized or grounding-type plug. A polarized plug has two blades with one wider than the other. A grounding-type plug has two blades and a third grounding prong. The wide blade or the third prong are provided for your safety. If the provided plug does not fit into your outlet, consult an electrician for replacement of the obsolete outlet.
- 10) Protect the power cord from being walked on or pinched particularly at plugs, convenience receptacles, and the point where they exit from the apparatus.
- 11) Only use attachments/accessories specified by the manufacturer.
- 12) Use only with the cart, stand, tripod, bracket, or table specified by the manufacturer, or sold with the apparatus. When a cart is used, use caution when moving the cart/apparatus combination to avoid injury from tip-over.
- 13) Unplug this apparatus during lightning storms or when unused for long periods of time.
- 14) Refer all servicing to qualified service personnel. Servicing is required when the apparatus has been damaged in any way, such as power-supply cord or plug is damaged, liquid has been spilled or objects have fallen into the apparatus, the apparatus has been exposed to rain or moisture, does not operate normally, or has been dropped.



INTRO

Features

This Recordable DVD Home Theater System allows you to enjoy high quality video and audio recordings providing you with a complete home entertainment package.

■ A variety of discs can be played

In addition to DVD-Video movies, this unit can play a variety of discs including multi-channel DVD-Audio, audio CDs, and Video CDs. You can also play MP3 files recorded on CD-R and CD-RW discs.

■ Editing your recording **RAM**

- You can divide programs (⇒ page 31).
- Use play lists (⇒ page 27) to select your favorite scenes and rearrange them to play in any order you like.

■ Enjoying television programs in surround sound

- You can enjoy recorded and broadcast television programming in surround sound with Dolby Pro Logic II.
- You can also enjoy satellite television and CATV digital multi-channel audio by connecting with an optical cable.

■ Exceptional sound and picture quality when recording

- Audio is recorded using Dolby Digital stereo, enabling high quality sound recordings. When recording in XP mode it is possible to use LPCM (2 channel) to achieve sound recordings of even higher quality.
- The encoder system used for recording is called "Hybrid VBR" and allows high quality recordings.

■ Fast access to the program you want to watch (⇒ page 19) **RAM DVD-R**

Use the Direct Navigator to find a program you have recorded and start play.

■ Make your own DVD-Video

Finalizing a DVD-R that has been recorded on produces an original DVD-Video in accordance with DVD-Video standards.

■ Maximum 12 hours on DVD-RAM

- Using a double sided, 9.4 GB DVD-RAM allows you to record a maximum of 12 hours (6 hours continuously).
- You can also use the FR (Flexible Recording) mode to fit recordings efficiently onto the available space on the disc.

■ Progressive Scan

By connecting the component video terminal of this unit to a progressive scan television, it is possible to enjoy the high quality picture rendered by the progressive scan function.

■ Quick View (⇒ page 20) **RAM**

You can speed up play to make checking the contents faster. Both video and sound are played faster.

■ The FUNCTIONS window shows you most of the features you can use (⇒ page 25)

The FUNCTIONS window has most of the features and functions you are likely to use regularly. Just select the icon for the operation you want to perform.

■ Watch a program while you are recording it (⇒ page 17) **RAM**

Chasing Play

You can watch a program from the start while you are still recording it.

Simultaneous rec and play

You can record a program while watching one you recorded previously.

Time Slip

You can jump back to review a piece of action you missed while recording by pressing the time slip button.

- During playback, you can specify a length of time to jump to the scene you wish to view.

The manufacturer accepts no responsibility and offers no compensation for loss of recorded or edited material due to a problem with the unit or recordable media, and accepts no responsibility and offers no compensation for any subsequent damage caused by such loss.

Examples of causes of such losses are

- A disc recorded and edited with this unit is played in a DVD recorder or computer disc drive manufactured by another company.
- A disc used as described above and then played again in this unit.
- A disc recorded and edited with a DVD recorder or computer disc drive manufactured by another company is played in this unit.

Remote control and subwoofer

If **[SHIFT]** appears after the button name the function will not work unless you use in combination with the **[SHIFT]** button. Make sure you first press and hold the **[SHIFT]** button.

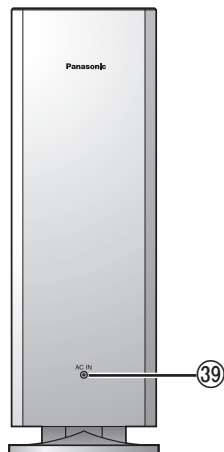
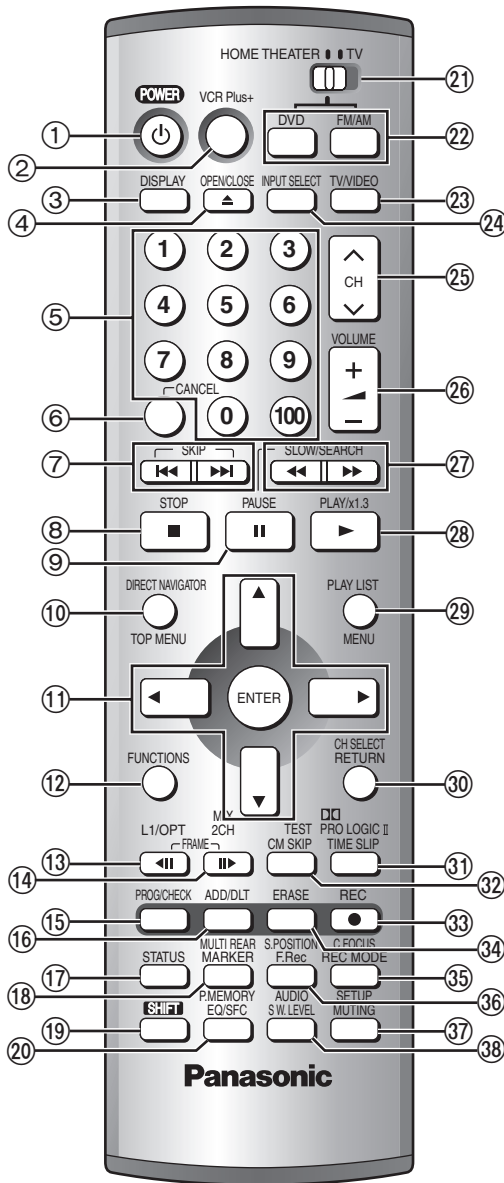

- ① **POWER button** [**POWER**] 9
Press to switch the unit from on to standby mode or vice versa. In standby mode, the unit is still consuming a small amount of power.
- ② **VCR Plus+ button** [**VCR Plus+**] 14
- ③ **On-screen menu button** [**DISPLAY**] 22
- ④ **Disc tray open/close button** [**OPEN/CLOSE**] 12
- ⑤ **Numbered buttons** [1–9, 0, 100]
- ⑥ **Cancel button** [**CANCEL**] 10
- ⑦ **Skip buttons** [**SKIP**] 18
- ⑧ **Stop button** [**STOP**] 12
- ⑨ **Pause button** [**PAUSE**] 12
- ⑩ **Direct Navigator, Top menu button** [**DIRECT NAVIGATOR, TOP MENU**] 19, 21
- ⑪ **Cursor buttons** [**▲, ▼, ◀, ▶**], **Enter button** [**ENTER**] 9
- ⑫ **Functions button** [**FUNCTIONS**] 25
- ⑬ **Frame reverse button** [**◀||| FRAME**] 18
- ⑭ **L1 input analog/optical selector button** [**L1/OPT**] **[SHIFT]** 45
- ⑮ **Frame advance button** [**|||▶ FRAME**] 18
- ⑯ **Down-mix button** [**MIX 2CH**] **[SHIFT]** 36
- ⑰ **Manual programming and check button** [**PROG/CHECK**] 15
- ⑱ **Manual channel adding and deleting button** [**ADD/DLT**] 9
- ⑲ **On-screen display button** [**STATUS**] 24
- ⑲ **Marker button** [**MARKER**] 18
- ⑲ **Virtual rear/multi rear surround button** [**MULTI REAR**] **[SHIFT]** 37
- ⑲ **Shift button** [**SHIFT**]
To use the functions labeled in orange, press the button while pressing **[SHIFT]**.
- ⑲ **Equalizer/sound field control button** [**EQ/SFC**] 36
- ⑲ **Position memory button** [**P.MEMORY**] **[SHIFT]** 19
- ⑲ **Remote control mode selector switch** [**HOME THEATER, TV**] 11
Switch to “HOME THEATER” when operating the main unit, or switch to “TV” when operating the television.
- ⑲ **Main unit selector button**
DVD/CD source button [**DVD**] 9
Switch the source on the main unit to DVD.
Tuner/band button [**FM/AM**] 34
Switch the source on the main unit to tuner and change the band.
- ⑲ **Television input mode selector** [**TV/VIDEO**] 11
- ⑲ **Input select button** [**INPUT SELECT**] 13
- ⑲ **Channel buttons for recorder, tuner, and TV** [**▲ ▼ CH**] 11, 12, 34
- ⑲ **Volume buttons for recorder, tuner, and TV** [**+ – VOLUME**] 11, 18, 34
- ⑲ **Slow/search, Tuning buttons** [**◀◀ ▶▶ SLOW/SEARCH**] 18, 34
- ⑲ **Play/quick view button** [**▶ PLAY/x1.3**] 18, 20
- ⑲ **Play list, Menu button** [**PLAY LIST, MENU**] 19, 27
- ⑲ **Return button** [**RETURN**] 10
- ⑲ **Speaker channel button** [**CH SELECT**] **[SHIFT]** 37
- ⑲ **Time slip button** [**TIME SLIP**] 17, 20
- ⑲ **Dolby Pro Logic II button** [**PRO LOGIC II**] **[SHIFT]** 36
- ⑲ **One-minute skip button** [**CM SKIP**] 20
- ⑲ **Test signal button** [**TEST**] **[SHIFT]** 37
- ⑲ **Recording button** [**REC**] 12
- ⑲ **Program/play list erase button** [**ERASE**] 18
- ⑲ **Recording mode button** [**REC MODE**] 12
- ⑲ **Center focus button** [**C.FOCUS**] **[SHIFT]** 36
- ⑲ **Flexible Recording button** [**F.Rec**] 13
- ⑲ **Seat position button** [**S.POSITION**] **[SHIFT]** 37
- ⑲ **Muting button** [**MUTING**]
Volume is reduced to minimum.
To cancel, press **[MUTING]** again or reduce the volume to minimum (– dB), then raise it to the required level.
Muting is also canceled when you switch the unit to standby.
- ⑲ **Setup button** [**SETUP**] **[SHIFT]** 10
- ⑲ **Bass adjust button** [**S.W.LEVEL**] 37
- ⑲ **Audio, Dynamic range compression button** [**AUDIO**] **[SHIFT]** 13, 19, 45
- ⑲ **AC power supply indicator** [**AC IN**]
This indicator lights when the subwoofer is connected to a household AC outlet.

Main unit and display

Controls such as ❶ function the same as the buttons on the remote control.

- ❶ Remote control signal sensor
- ❷ Standby/on indicator [⏻/I]
- When the unit is connected to the AC power supply, this indicator lights up in standby mode and goes out when the unit is turned on.
- ❸ Channel buttons for recorder and tuner
- [V, ^ CHANNEL] 12, 34
- ❹ Main unit selector buttons and indicators
- DVD/CD source button [DVD] 9
- Switch the source on the main unit to DVD.
- Tuner/band button [FM/AM] 34
- Switch the source on the main unit to tuner and change the band.
- The indicator of the currently selected mode lights up.
- ❺ Disc tray 12
- ❻ Preset memory button [MEMORY] 34
- ❼ Radio reception mode button [FM MODE] 34

- ❽ Volume dial for recorder and tuner
- [VOLUME DOWN, UP] 18, 34
- ❾ Skip/Slow/Search, Tuning buttons
- [◀◀/◀, ▶/▶▶, √ TUNING ^] 18, 34
- ❿ L2 input terminals [L2] 44
- ⓫ Time slip button and indicator [TIME SLIP] 17, 20
- ⓬ Headphone terminal [PHONES]
- 1 Reduce the volume and connect the headphones (not included).
- 2 Adjust headphone volume with [VOLUME DOWN, UP].
- Headphone plug type: 3.5 mm (1/8") stereo
- Audio is automatically switched to stereo (2-channel).

Note

Do not play your headphones at a high volume. Hearing experts advise against continuous extended play.

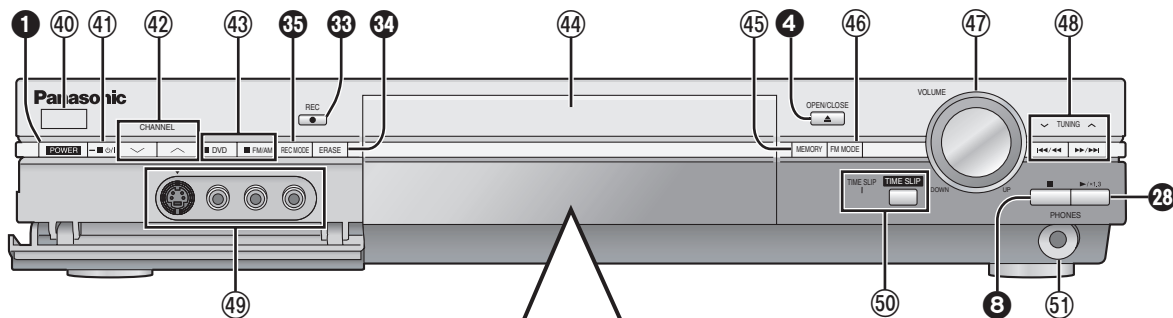

Display

Circle display (e.g., DVD-RAM)

Rotating (REC): recording
Stopped (REC): recording paused



Rotating (REC, PLAY):
Chasing play or simultaneous rec and play is in progress

Rotating (PLAY): playing
Stopped (PLAY): play paused
"PLAY" flashes:
the resume play function (→page 18) is working

- A** Timer recording display 14
- On:** When timer recording is on standby
- Flashes:** When the unit couldn't go to timer recording standby
- B** Disc type
- C** The display mode of the main display section
- GRP:** Group number
- TITLE:** Title number
- PL:** Play list number
- CHAP:** Chapter number
- PG:** Program number
- TRACK:** Track number
- D** Recording mode 12
- E** DVD indicator
- Flashes:** When you press [⏻ POWER] to turn the unit off until it actually turns off

- F** Main display section
- Recording and play counter, and other miscellaneous messages
- G** Down-mix indicators 36
- H** Virtual rear/multi rear surround indicator 37
- I** Center Focus indicator 36
- J** Radio broadcast display 34
- TUNED:** Receiving radio signal
- ST:** Stereo
- MEMO:** Channel preset memory indicator
- K** Channel
- L** DTS indicator 36
- M** Equalizer/sound field control indicator 36
- N** Dolby Pro Logic II indicator 36
- O** Radio frequency unit indicator
- P** Dolby Digital indicator 36
- Q** Speaker channel, seat position display 37

Discs you can use for recording and play

Disc type	Logo	Indication used in instructions
DVD-RAM ● 4.7 GB/9.4 GB, 12 cm (5") ● 2.8 GB, 8 cm (3")		RAM
DVD-R (for General Ver. 2.0) ● 4.7 GB, 12 cm (5") ● 1.4 GB, 8 cm (3")		DVD-R (Before finalizing) <hr/> DVD-V (After finalizing)

- We recommend using Panasonic discs as they have been confirmed to be compatible with this unit. Other discs may not perform correctly.
- Do not allow the disc to become dirty or scratched. Fingerprints, dirt, dust, scratches or deposits of cigarette smoke on the recording surface may make it impossible to use the disc for recording.
- Discs with programs recorded in PAL already cannot be recorded on with this unit.
- This unit is compatible with the **Content Protection for Recordable Media (CPRM)** (⇒ page 51) system so you can record broadcasts that allow one copy, such as some CATV broadcasts, onto 4.7 GB/9.4 GB DVD-RAM (these are CPRM compatible). It is not possible to record onto DVD-R or 2.8 GB DVD-RAM.

■ DVD-RAM

- **DVD-RAM recorded on this unit may not be compatible with other DVD players, including some Panasonic players. Consult the manual for the player to determine compatibility with these DVD-RAM discs.**
- This unit is compatible with both non-cartridge and cartridge DVD-RAM, but the write-protect tabs on cartridge-type discs give better protection to your recordings.
- Picture aspect ratios, regular 4:3 or widescreen 16:9, are recorded as they are received.

■ DVD-R

- **In order to play a DVD-R recorded using this unit on another playback source, the disc must first be finalized (⇒ page 33).**
- Once a DVD-R is finalized, it becomes DVD-Video.
- You can record onto the available space on the disc and perform editing functions, such as giving titles to discs and programs and erasing programs before finalizing.
- When programming is erased from a DVD-R, that space does not become available. Once an area on a DVD-R is recorded on, that area is no longer available for recording, whether the recording is erased or not.
- It takes about 30 seconds for the unit to complete recording management information after recording finishes.
- This unit optimizes the DVD-R for each recording. Optimizing is carried out when you start recording after inserting the disc or turning on the unit. Recording onto the disc may become impossible if optimizing is carried out too many times.
- The video is recorded in a 4:3 aspect irrespective of the video signal input.
- Play may be impossible in some cases due the condition of the recording.
- A DVD-R recorded on this unit may not be recordable on other Panasonic DVD recorders.



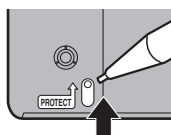

■ Protection **RAM**

You can protect the contents of your discs in the following ways.

- **Cartridge-protect:**
With the write-protect tab in the protect position, you cannot record to, edit, or erase from the disc. (Type 1, 2, and 4 cartridge discs)
- **Program-protect** (⇒ page 30)
- **Disc-protect** (⇒ page 32)



Play-only discs

Disc type	Logo	Indication used in instructions
DVD-Audio		DVD-A
DVD-Video		DVD-V
Video CD		VCD
Audio CD		CD
CD-R/RW	—	VCD CD MP3 (Depending on the recording format ⇒ below)

- This unit can play CD-R/CD-RW (audio recording disc) recorded with CD-DA (digital audio), video CD (video CD format 2.0) or MP3. Close the sessions or finalize the disc after recording. Play may be impossible on some CD-R or CD-RW discs due to the condition of the recording.
- The producer of the material can control how DVD-Video and Video CDs are played. So you may not always be able to control play as described in these operating instructions. Read the disc's instructions carefully.

■ Discs that cannot be played

- DVD-Video with a region number other than "1" or "ALL"
- 12-cm (5"), 2.6- and 5.2-GB DVD-RAM
- DVD-RAM not recorded following the Video Recording Standard
- 3.95- and 4.7-GB DVD-R for Authoring
- Unfinalized DVD-R recorded on other equipment
- PAL discs
- DVD-ROM
- DVD-RW
- +RW
- CD-ROM
- CDV
- CD-G
- Photo CD
- CVD
- SVCD
- SACD
- MV-Disc
- PD
- Divx Video Disc, etc.

■ Disc structure

Disc structure and the labels given to the items on discs depend on the disc type.

- Track:** the smallest division on DVD-Audio, CDs and Video CDs, or a single MP3 file.
- Chapter:** the smallest division on DVD-Video.
- Group:** collections of tracks on DVD-Audio and equivalent to folders or albums on data discs.
- Title:** the largest division on DVD-Video, usually an entire movie.
- Program:** the division on DVD-RAM equivalent to a single recording.
- Play list:** a group of scenes on DVD-RAM.
- Scene:** DVD-RAM program sections specified and grouped into play lists on a DVD video recorder.

STEP 1 Plug-in Auto Tuning

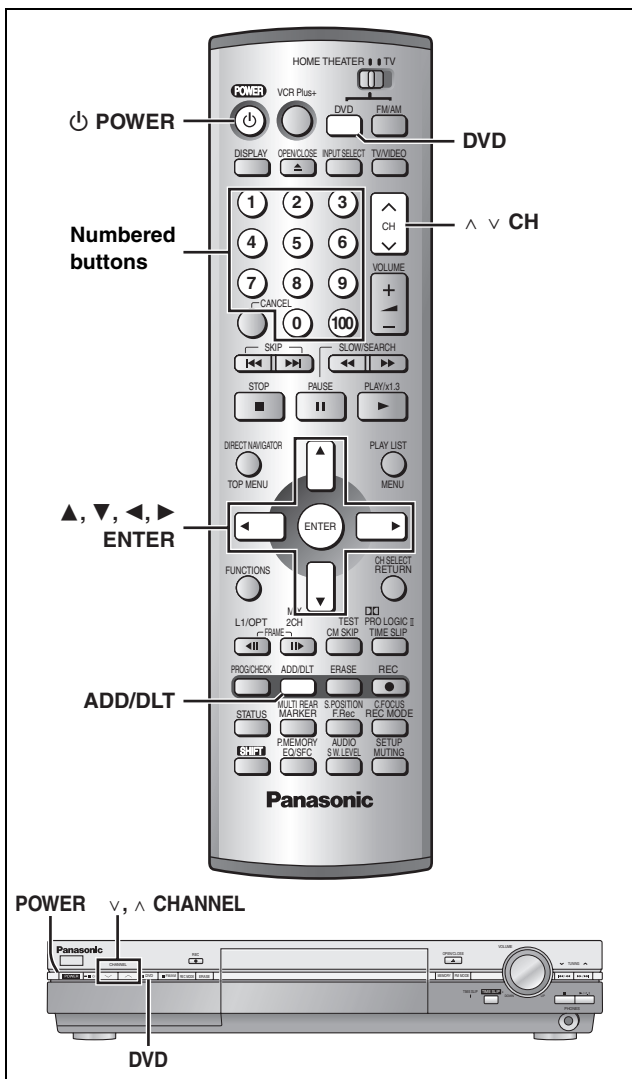

After plugging the unit into your household AC outlet and pressing [POWER] to turn the unit on for the first time, the unit assists you to set the menu language, and automatically tunes in all the channels it can receive and sets the clock.

The unit automatically determines the type of transmission (airwaves or cable) and puts them into channels as follows.

	Band	Channel
TV Mode (Airwaves)	VHF	2–13
	UHF	14–69
CATV Mode (Cable)	VHF	2–13
	CATV LOW BAND	95–99
	CATV MID/SUPER BAND	14–36
	CATV HYPER BAND	37–65
	ULTRA BAND	66–94 100–125
	SPECIAL CATV CHANNEL	1

Preparation

- Confirm that the antenna is connected correctly.
- Turn on the television and select the appropriate video input to suit the connections to this unit.
- Press [DVD] to select "DVD/CD" as the source.

1 Press [POWER] to turn the unit on.

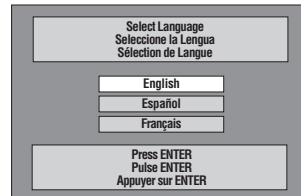

2 Press [▲, ▼] to select the menu language and press [ENTER].

3 Press [ENTER] to start Plug-in Auto Tuning.

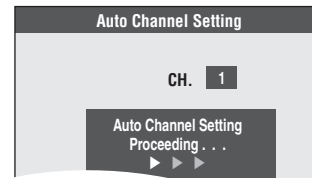

The unit then proceeds with Auto Clock Setting. The time is displayed when finished. If the clock is an hour slower or faster than the actual time, go to "Time Zone Adjust" to correct it (⇒ page 43).

4 When the display shows the correct time Press [ENTER] to complete Plug-in Auto Tuning.

■ If the unit couldn't set the clock automatically Press [ENTER] to show the "Manual Clock Setting" screen. Set the time manually (⇒ page 43).

■ To start Plug-in Auto Tuning again (after relocation, for example)

Antenna system, channel caption, and VCR Plus+ guide channel settings all revert to the default values when you perform the procedure below. Timer recording settings are also cleared.

When the unit is on and stopped

① Press and hold [v CHANNEL] and [^ CHANNEL] on the main unit for about five seconds.

The unit turns off.

② Press [POWER] to turn the unit on.

Follow the above steps 2–4.

■ If Plug-in Auto Tuning fails (⇒ page 40, Antenna System and Auto Channel Setting)

Adding and deleting channels

Add or delete channels if necessary channels are not set or unnecessary channels are set.

While this unit is receiving the antenna signal (but not during recording):

1 Press the numbered buttons to select a channel.

e.g., "5": [0] ⇒ [5]

"15": [1] ⇒ [5]

"115": [100] ⇒ [1] ⇒ [5]

Unit's display



- You can also use [^ v CH] when you are going to delete a channel.

2 Press [ADD/HLT].

The channel is **deleted** if it was set or **added** if it was not set. e.g.,



Repeat steps 1 and 2 as necessary.

STEP 2 VCR Plus+ guide channel settings

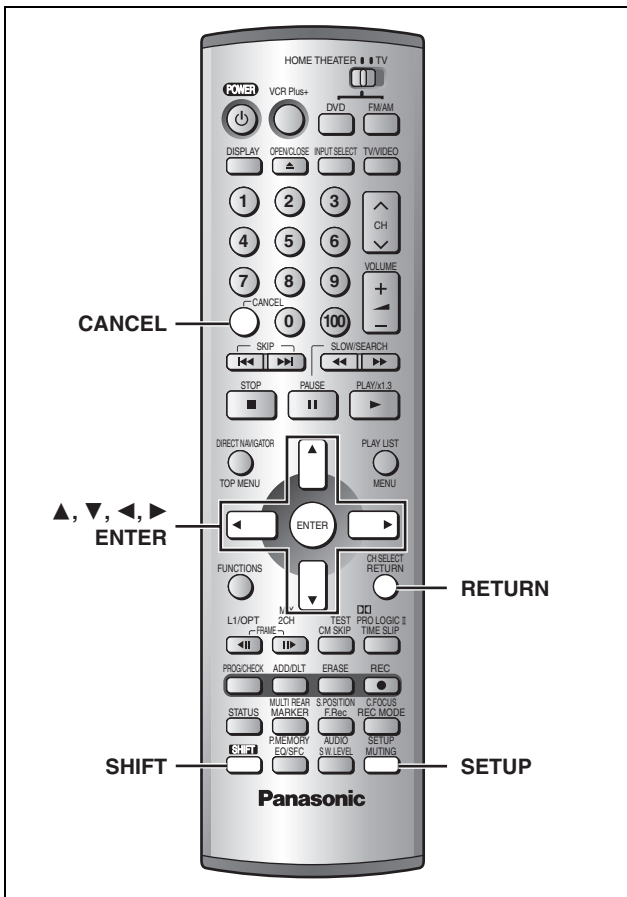

Set these guide channels so you can use VCR Plus+ codes for timer recording. Before starting the settings, prepare a chart showing the channels, station names, and guide channels.

e.g.,

Station name	Guide channel	Channel number	Channel setting (in step 5)
CBS	04	04	Unnecessary
HBO	33	15	Enter channel 15 next to Guide Channel 33.
Nickelodeon	38	20	Enter channel 20 next to Guide Channel 38.

Look up the guide channels for the stations in magazines.

Write down all the stations you can receive.

1 Press [SHIFT]+[SETUP] to show the menus.

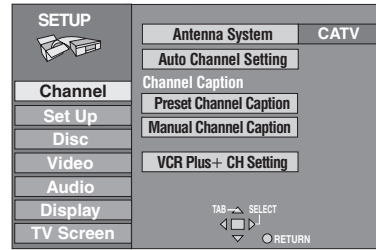

2 Press [▲, ▼] to select “Channel” and press [▶].

3 Press [▲, ▼] to select “VCR Plus+ CH Setting” and press [ENTER].
e.g., when the current antenna system is CATV.

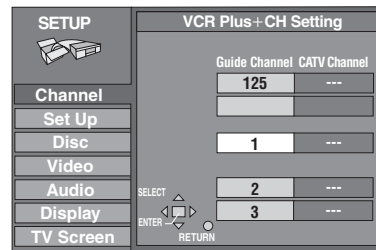

4 Press [▲, ▼] to select the guide channel you want to set and press [▶].

When selecting the guide channel, press and hold [▲, ▼] to scroll the screen up and down.

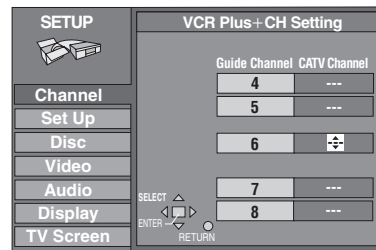

5 Press [▲, ▼] to select the channel corresponding to the guide channel and press [◀].

To delete a number, press [CANCEL].

Repeat steps 4 and 5 as necessary.

6 Press [ENTER].

The “Channel” screen reappears.

To return to the previous screen

Press [RETURN].

To exit the SETUP screen

Press [SHIFT]+[SETUP].

VCR Plus+ and PlusCode are registered trademarks of Gemstar Development Corporation. The VCR Plus+ system is manufactured under license from Gemstar Development Corporation.

Pats. 5,307,173; 5,335,079; 4,908,713; 4,751,578; and 4,706,121

STEP 3 Set up to match your television

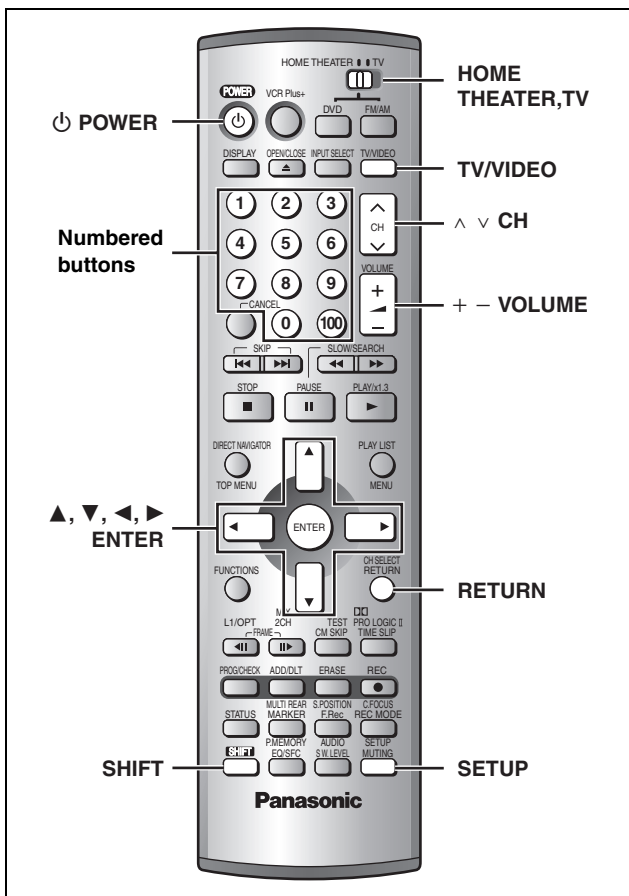

Change the settings if your television is:

- Progressive
–Read your television's operating instructions for details.
- Widescreen (16:9 aspect ratio)

- 1 Press [SHIFT]+[SETUP] to show the menus.
- 2 Press [▲, ▼] to select "TV Screen" and press [▶].
- 3 Press [▲, ▼] to select "TV Type" and press [ENTER].

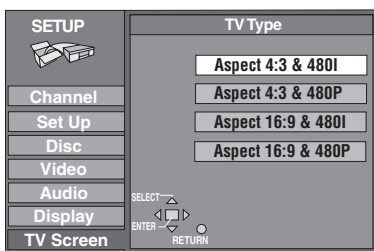

- 4 Press [▲, ▼] to select the item and press [ENTER].

If you select a progressive output (480P) item, select Video in the on-screen menu and set "Transfer" to suit the material (⇒ page 23).

To return to the previous screen
Press [RETURN].

To exit the SETUP screen
Press [SHIFT]+[SETUP].

■ Regarding Progressive Television Picture

Progressive image aspect (height to width ratio) is set at a standard 16:9. DVD-Video which has been set at 16:9 will be displayed correctly. However, 4:3 video material will be stretched to the right and left when displayed.

•To view the picture at the right aspect

- For televisions that allow the aspect of progressive images to be adjusted, use the function provided on the television and adjust as necessary.
- For televisions which do not allow the aspect of progressive images to be adjusted, please set "Progressive" to "OFF" (⇒ page 23).

Note

- If the unit is connected to the TV through VIDEO OUT or S-VIDEO OUT, output will be interlace only (even if you select progressive output).
- When progressive output is on, closed captions cannot be displayed.

Television operation

You can control televisions by entering the remote control code.

- 1 Switch [HOME THEATER, TV] to "TV".
- 2 While pressing [POWER], enter the two-digit code with the numbered buttons.
e.g., 01: press [0] ⇒ [1].

Code No. and Manufacturer

01	Panasonic/National QUASAR	11	JVC
02		12	HITACHI
03	MAGNAVOX SYLVANIA PHILIPS (RC-5)	13	mitsubishi
04	ZENITH	14	SAMSUNG
05	THOMSON RCA GE	15	GOLDSTAR/LG
06	SHARP	16	
07		17	
08	SONY	18	SAMSUNG
09	TOSHIBA	19	
10	SANYO FISHER		–

Test by turning on the television and changing channels. Repeat the procedure until you find the code that allows correct operation.

Note

If your television brand is not listed or if the code listed for your television does not allow control of your television, this remote control is not compatible with your television.

■ Operation

Switch [HOME THEATER, TV] to "TV" and point the remote control at the television.

Operation	Button
On and off	[POWER]
TV/Video switch	[TV/VIDEO]
Selecting channels	[^ v CH] or Numbered buttons
Adjusting volume	[+ - VOLUME]

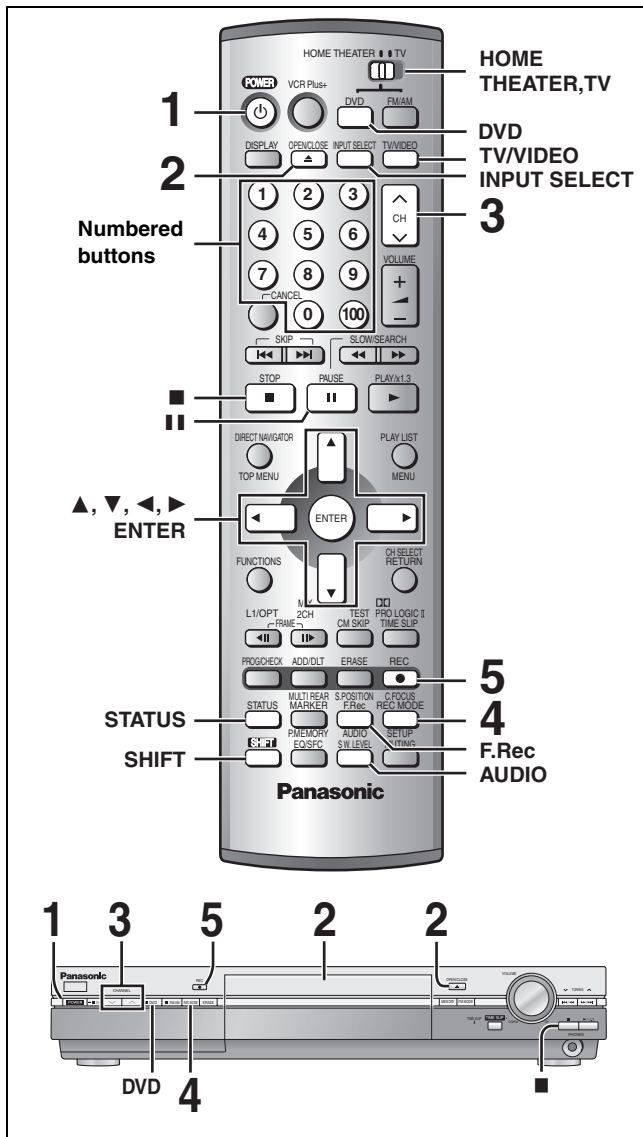

RAM DVD-R

Preparation

- Release protection (cartridge → page 8, disc → page 32) when you record. **RAM**
- Switch [HOME THEATER, TV] to “HOME THEATER”.
- Press [DVD] to select “DVD/CD” as the source.

1 Press [POWER] to turn the unit on.

2 Press [▲ OPEN/CLOSE] to open the tray and insert a disc (→ left).
Press the button again to close the tray.

3 Press [^ v CH] to select the channel.

To select with the numbered buttons:

e.g. 5: [0] → [5]

15: [1] → [5]

115: [100] → [1] → [5]

4 Press [REC MODE] to select the recording mode (→ below).

To record sound using LPCM (XP mode only):

From the SETUP menu, set the “Audio Mode for XP Recording” setting to “LPCM” (the picture quality may go down slightly). (→ page 39)

5 Press [● REC] to start recording.

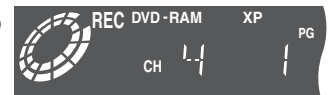

- Recording will take place on open space on disc. Data will not be overwritten.
- Program information (e.g., time and date) is registered in the program list (→ page 19, Using the Direct Navigator).

DVD-R

To play DVD-R on compatible equipment, finalize it (→ page 33).

To stop recording

Press [■].

To pause recording

Press [⏸]. Press again to restart recording.

(Program is not split into a separate program.)

Note

- You cannot change the channel or recording mode during recording.
- When using a DVD-RAM for the first time with this unit, format it to ensure accurate recording (→ page 33).
- There are limitations when recording to DVD-R (→ page 8).
- It is not possible to record CPRM (→ page 51) protected material onto DVD-R or 2.8 GB DVD-RAM discs.

For your reference

- You can record up to 99 programs on one disc.

Recording modes and approximate recording times in hours

Mode	Disc	DVD-RAM		DVD-R (4.7 GB)
		Single-sided (4.7 GB)	Double-sided (9.4 GB)	
XP (High quality)		1	2	1
SP (Normal)		2	4	2
LP (Long play)		4	8	4
EP (Extra long play)		6	12	6

Depending on the content being recorded, the recording times may become shorter than indicated.

FR (Flexible Recording Mode)

The unit automatically selects a recording rate between XP and EP that will enable the recordings to fit in the available recording time on the disc with the best possible recording quality.

- You can set for timer program recording (→ page 14).

- All the recording modes from XP to EP appear in the display.

XP SP LP EP

Inserting discs

You can insert a cartridge or non-cartridge disc.

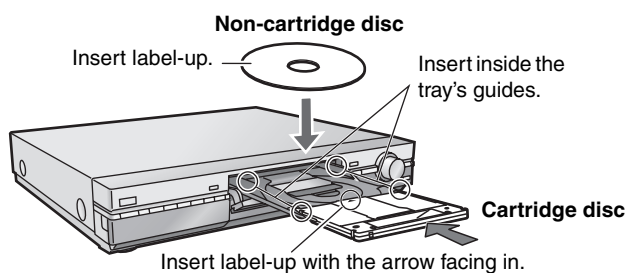

- Load double-sided discs so the label for the side you want to record/play is facing up.
- When using 8 cm (3") DVD-RAM, remove the disc from the cartridge and insert it, making sure you align it with the groove.
- **It is not possible to record/play continuously from one side of a double sided disc to the other. You will need to eject the disc and turn it over.**

Should the AC power supply cord come loose by accident or for any other reason the power supply is cut off while recording or editing is taking place, the contents of the disc may be lost.

Recording the best quality pictures within the set amount of time—Flexible Recording

The unit calculates a recording rate that enables the recording to fit in the time you set (within the remaining time on the disc) and with the best possible picture quality.

- 1 While stopped
Press [F.Rec].
- 2 Press [◀, ▶] to select “Hour” and “Min.” and press [▲, ▼] to set the recording time.

You can also set the recording time with the numbered buttons.

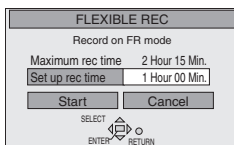

- 3 Press [▲, ▼, ▶, ◀] to select “Start” and press [ENTER].

Recording starts.

To show the remaining time

Press [STATUS].

Note

It may not be possible to record to the end of the program if the remaining time doesn't allow.

For your reference

- Recording time is reduced if you repeatedly pause recording.
- The recording mode automatically becomes FR mode.

Selecting the audio recording mode

RAM

To change the audio recording mode

Press [SHIFT]+[AUDIO].

■ While receiving MTS audio (Multi-channel Television Sound Stereo)

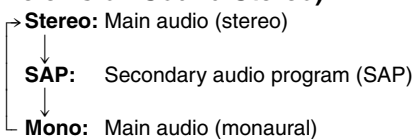

e.g., “Stereo” is selected

“(” appears when the unit is receiving the audio type you selected.



Note

- If you change the sound setting while recording, the recorded sound will also change. **RAM**
- If recorded in SAP mode, main audio is also recorded. **RAM**
- It will not be possible to alter the sound in the following cases:
 - When a DVD-R is in the disc tray.
 - When recording mode is XP and “LPCM” has been selected in the Audio menu, “Audio Mode for XP Recording” (⇒ page 39).
- When recording MTS sound onto DVD-R or recording using LPCM, only one of either the main channel or the sub channel can be recorded. Select at “Select MTS” (⇒ page 39).
- If the broadcast is “Mono+SAP”, audio will be monaural even if you select Stereo mode.
- Select “Mono” if reception is poor during a stereo broadcast.

Watching the television while recording

Pictures being recorded are unaffected.

- 1 Switch [HOME THEATER, TV] to “TV”.
- 2 Press [TV/VIDEO] to change the television's input mode to “TV”.
- 3 Press [^ v CH] to change channels.
You can also select the channel with the numbered buttons.

Specify a time to stop recording

This is a simple way of specifying a time to stop recording when you are in a hurry or before you go to bed.

During recording

Press [● REC] to select the recording time.

Each time you press the button:

0:30 → 1:00 → 1:30 → 2:00 → 3:00 → 4:00
 Counter (cancel) ←

e.g.,



To show the remaining time

Press [STATUS].

For your reference

- This does not work during timer recordings (⇒ page 14) or while using Flexible Recording (⇒ left).
- Recording stops and the set time is cleared if you press [■].
- The set time is cleared if you change the recording mode or channel while recording is paused.

Recording from a video cassette recorder

Preparation

Connect a video cassette recorder to this unit's input terminals (⇒ page 44).

- 1 While stopped
Press [INPUT SELECT] to select the input channel for the equipment you have connected.
Select L1, L2 or L3.
•You can also select the input channel by pressing [^ v CH].
- 2 Press [REC MODE] to select the recording mode (XP, SP, LP or EP).
- 3 Start play on the other equipment.
- 4 Press [● REC] at the point you want to start recording.
Recording starts.

To skip unwanted parts

Press [■] to pause recording. (Press again to restart recording.)

To stop recording

Press [■].

Note

- When recording using L1, L2 or L3 terminals, only the sound received at the time of recording will be recorded.
- If Flexible Recording (⇒ left) is used instead of steps 2 and 4, settings can be made so that recording continues to the end of the video.

Almost all videos and DVD software on sale have been treated to prevent illegal copying. Any software that has been so treated cannot be recorded using this unit.

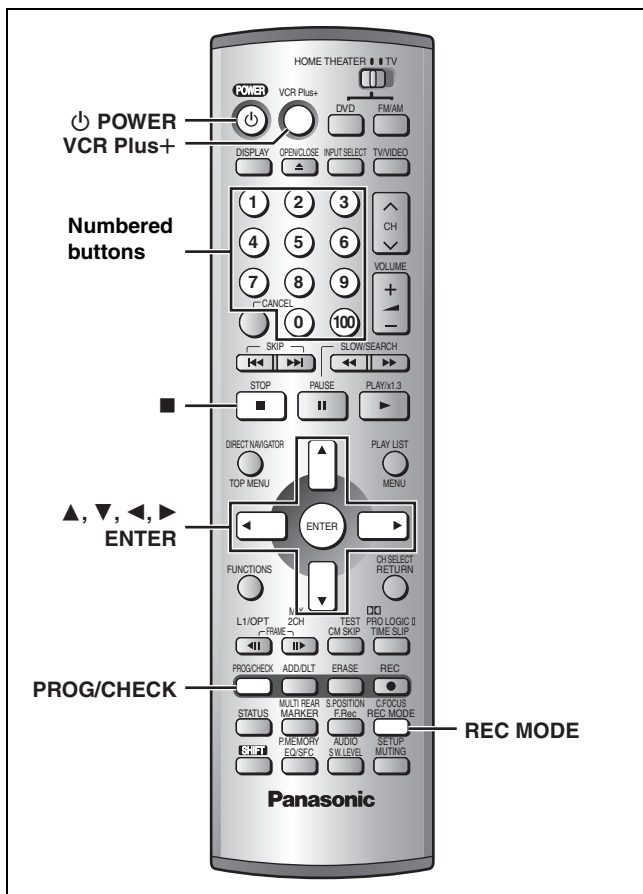

RAM DVD-R

You can enter up to 16 programs up to a month in advance. (Each daily or weekly program is counted as one program.)

Preparation

- Set the clock and guide channels for VCR Plus+ recording (→ page 10) correctly.
- Release protection before proceeding. **RAM** (Cartridge → page 8, disc → page 32)

Using VCR Plus+ codes to make timer recordings

Entering VCR Plus+ codes is an easy way of programming the unit for recording. You can find these codes in newspapers and magazines.

1 Press [VCR Plus+].

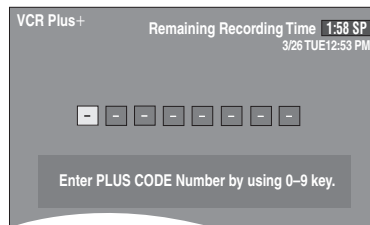

2 Press the numbered buttons to enter the VCR Plus+ code.

Press [◀] to move back to correct a digit.

3 Press [ENTER].

Confirm the program and make corrections if necessary using [▲, ▼, ◀, ▶].

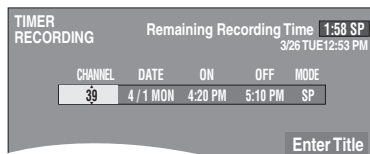

• "Invalid Entry" is displayed when you enter the wrong code. Reenter the code.

• **To change the recording mode**
Press [REC MODE].

• **To enter the title of the program**
Press [◀, ▶] to select "Enter Title" and press [ENTER] (→ page 26).

4 Press [ENTER].

The program timer recording settings are stored.

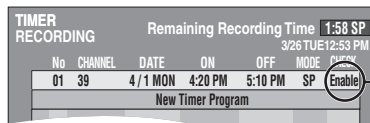

Displayed if the recording can fit in the remaining space on the disc.

Repeat steps 1–4 to program other recordings.

5 Press [PROG/CHECK].

The message "TURN RECORDER OFF FOR TIMER RECORDING." is shown on the television.

6 Press [POWER].

The "Ⓞ" lights on the unit's display to indicate timer recording standby has been activated.

Manually programming timer recordings

1 Press [PROG/CHECK].

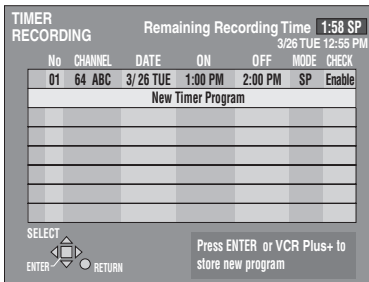

2 Press [▲, ▼] to select “New Timer Program” and press [ENTER].

3 Press [▶] to move through the items and change the items with [▲, ▼].

- The current settings are shown each time you press [▶].
- You may use the numbered buttons to enter the CHANNEL, DATE, ON (Start Time), and OFF (Finish Time).



•CHANNEL (Channel number and caption)

•DATE

→ Current date

↓ ↑

Next day up to one month later minus one day

↓ ↑

Weekly timer: SUN-SAT → MON-SAT → MON-FRI

↓ ↑

→ Daily timer: WEEKLY SUN → --- → WEEKLY SAT

•ON (Start time)/OFF (Finish time)

The time increases or decreases in 30-minute increments if you hold the button.

•MODE (Recording mode → page 12)

SP ↔ XP ↔ FR ↔ EP ↔ LP

•Enter Title

Select “Enter Title” using [◀, ▶] and press [ENTER] (→ page 26).

4 Press [ENTER] when you have finished programming the timer.

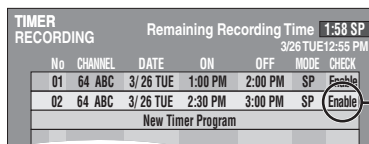

Displayed if the recording can fit in the remaining space on the disc.

Press [▲, ▼] to select “New Timer Program” and repeat steps 3–4 to program other recordings.

5 Press [PROG/CHECK].

The timer recording list disappears and the message “TURN RECORDER OFF FOR TIMER RECORDING” is shown on the television.

6 Press [POWER].

The “Ⓢ” lights on the unit’s display to indicate timer recording standby has been activated.

■ To release the unit from recording standby

If you want to record something else before the program start time, for example:

Press [POWER].

The unit turns on and “Ⓢ” goes out.

- Be sure to press [POWER] to return the unit to standby mode before the scheduled recording time. Timer recording will work only if “Ⓢ” is displayed.

■ To cancel recording when recording has already begun

Press [RECALL], then [ENTER] within 5 seconds.

Recording stops.

Note

- “Ⓢ” flashes when the unit couldn’t go to timer recording standby (e.g., a disc isn’t loaded, a disc that can’t be recorded to is loaded, or the disc is protected). Check the disc carefully.
- The actual time recorded may be longer than the program itself when television programs are recorded using VCR Plus+.
- If you don’t select a recording mode when using VCR Plus+ codes to make a timer recording, the unit sets the mode selected on the unit at that time (unless the mode is “XP”, in which case the unit sets “FR” as the mode).
- “All timer programs are occupied.” appears if there are already 16 programs.
- The remaining time displayed is based on the current recording mode.
- When you program successive timer recordings to start immediately one after the other, the unit cannot record the part at the beginning of the later programs (a few seconds when recording with DVD-RAM and approximately 30 seconds when recording with DVD-R).
- If you set DST (Daylight Saving Time) to ON when manually setting the clock (→ page 43), timer recording may not work when summer switches to winter and vice versa.

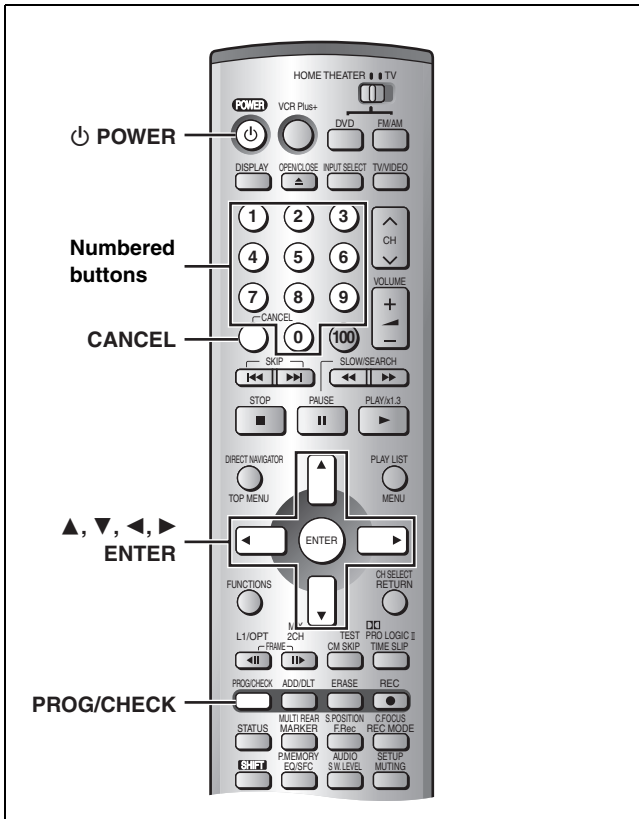

RAM DVD-R

Check programs

1 Press [PROG/CHECK].

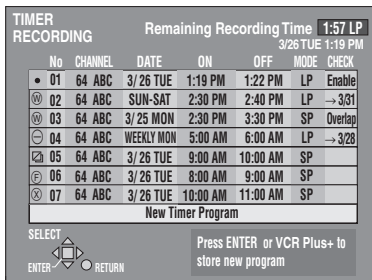

Icon explanations

- ⊙ The times overlap those in another program.
 - Note the following if times overlap:
 - The program with the earlier start time receives priority.
 - Recording of the program with the later start time starts when the earlier program finishes recording.
 - If you make two programs with the same start time, the one you programmed last receives priority.
 - ⊖ You stopped recording of a weekly or daily timer recording. The icon disappears the next time the timer starts recording.
 - This program is currently recording.
 - Ⓜ The disc was full or the maximum number of programs or scenes was reached so the program failed to record.
 - Ⓜ The material was copy-prohibited so it was not recorded.
 - ⊗ The program did not complete recording because the disc is dirty or some other reason.
- Programs that failed to record are displayed gray. They are automatically deleted from the timer recording list at 4 a.m. two days later.

To put the unit on timer recording standby

Press [POWER].
The unit turns off and “⊙” lights on the unit’s display.

Message displayed in the CHECK line

- Enable:** Displayed if the recording can fit in the remaining space on the disc.
- **(Date):** For recordings made daily or weekly, the display will show as long as recordings can be made (up to a maximum of one month from the present time) based on the time remaining on the disc.
- ! : It may not be possible to record because of write protection, because there is no more space left or because the number of possible programs has reached its maximum. Please check the disc.

2 Press [PROG/CHECK].

The timer recording list disappears.

Change or delete the program

1 Press [PROG/CHECK].

The timer recording list appears.

2 Press [▲, ▼] to select the program.

- You may also select programs with the numbered buttons.
 - e.g., “5”: [0] → [5]
 - “15”: [1] → [5]
- Press [◀, ▶] to skip down several programs on the list.

3 Press [CANCEL] to delete,

You cannot delete programs that are currently recording. or press [ENTER] to change.

The timer recording setting screen appears.

4 If you pressed [ENTER] in step 3,

Move through the items with [◀, ▶] and change the settings with [▲, ▼] and press [ENTER].

5 Press [PROG/CHECK].

The timer recording setting screen disappears.

Note

- During timer recording, you can change the end time as long as the recording mode is not “FR”.
- Even when the power is off, you can display the timer recording list by pressing [PROG/CHECK].

Playing while you are recording

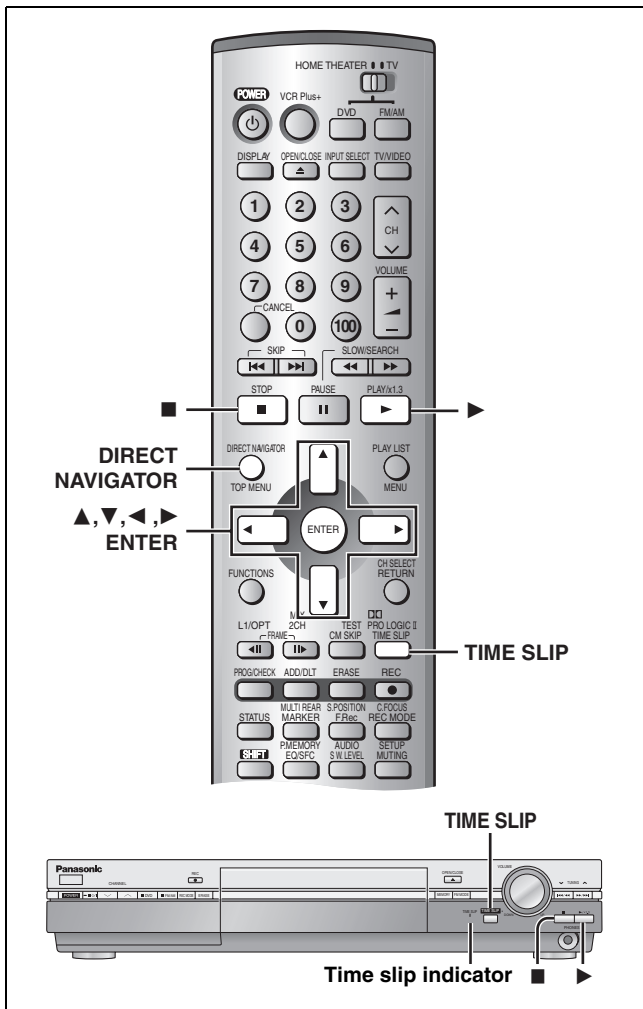

RAM

Playing from the beginning of the program while you are recording—Chasing Play

Press [▶] (PLAY).

Time slip indicator on the main unit lights.
Play starts from the beginning of the program being recorded.

e.g.,
You are recording a sports program and you want to watch it from the beginning.

The same sports program is played back from the beginning. (Recording continues.)

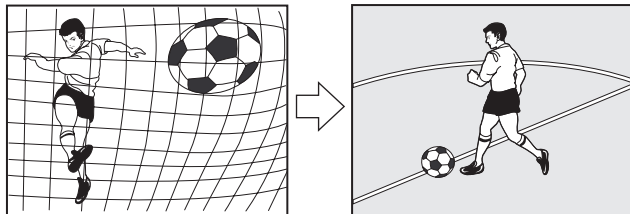

Note

Sound is not output while fast-forwarding.

Simultaneous rec and play

While recording, you can play a program previously recorded.

1 During recording

Press [DIRECT NAVIGATOR].

Time slip indicator on the main unit lights.

2 Press [▲, ▼] to select a program and press [ENTER].

e.g.,

You want to watch the movie you recorded yesterday while recording a sports program.

The movie is played back while the sports program is being recorded.

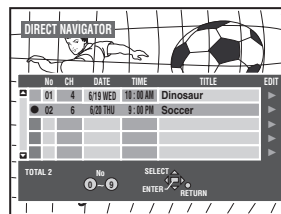

Note

- Sound is not output while fast-forwarding.
- You cannot edit programs during simultaneous rec and play (→ page 30).

Reviewing the recorded images while recording—Time Slip

While recording, you can specify the desired scene of the recorded program or program being recorded using the time setting and watch both in two on-screen windows.

1 Press [TIME SLIP].

Time slip indicator on the main unit lights.

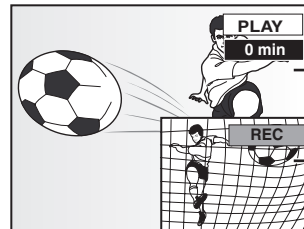

Play starts from 30 seconds previous.

The current recording images appear as a picture-in-picture.

• You will hear the playback audio.

• Press [DIRECT NAVIGATOR] to select another program.

2 Press [▲, ▼] to enter the time and press [ENTER].

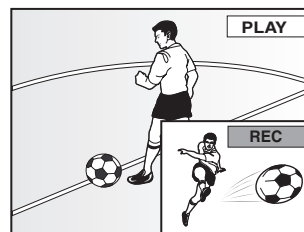

Press [▲, ▼] to alter in one-minute units. Press and hold [▲, ▼] to alter in 10-minute units.

Press [TIME SLIP] to show the play images in full. Press again to show the play and recording images.

■ To stop play and recording

- 1 Press [■]. (Play stops.)
Wait 2 seconds.
- 2 Press [■]. (Recording stops.)
 - To stop timer recording, press [■], then [ENTER] within 5 seconds.

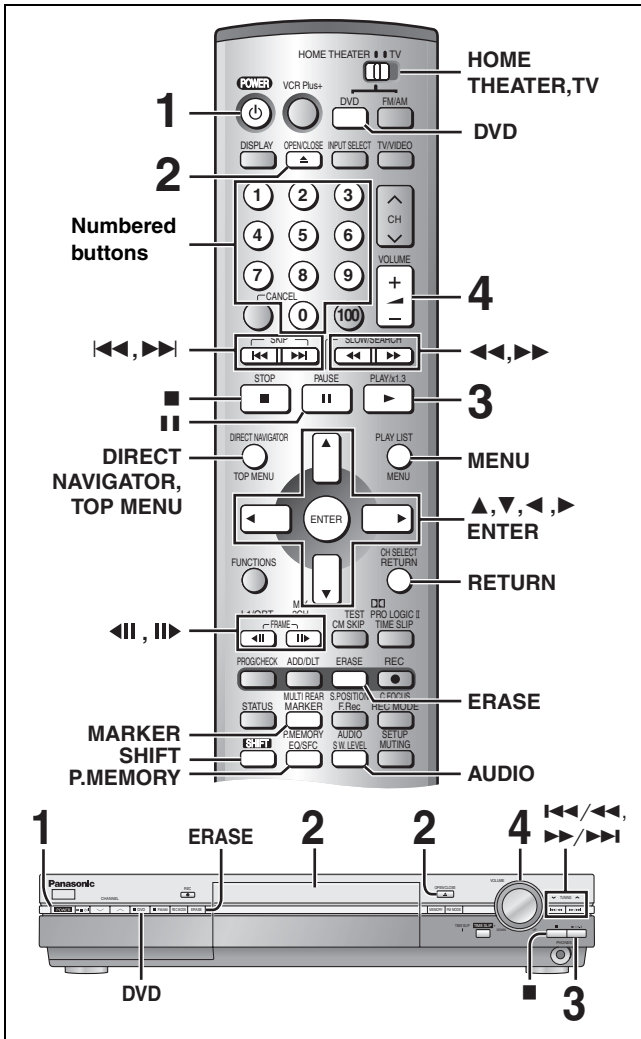

RAM DVD-R DVD-A DVD-V VCD CD MP3

Preparation

- Switch [HOME THEATER, TV] to "HOME THEATER".
- Press [DVD] to select "DVD/CD" as the source.

1 Press [POWER] to turn the unit on.

2 Press [OPEN/CLOSE] to open the tray and insert a disc (→ page 12).

- Press the button again to close the tray.
- If cartridge protection is activated (→ page 8), play begins automatically when you close the tray. **RAM**

3 Press [PLAY].

The unit takes some time to read the disc before play starts.

RAM DVD-R

- Play starts from the most recently recorded program.

DVD-A DVD-V VCD CD MP3

- Play starts from the beginning of the disc.

4 Adjust the volume.

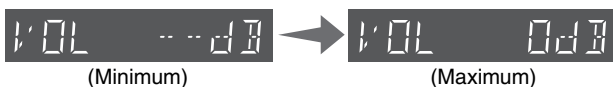

(Minimum)

(Maximum)

Note

- If a disc is loaded, the unit will come on and play will start when you press [PLAY].
- Actual sound levels for DVD-Video are lower compared to television broadcast or playback of other discs. To avoid a sudden increase in volume level when switching from DVD-Video, reduce the volume setting before playing other sources or switching to television broadcast.

Operations during play

Stop	Press [■]. Resume play function When "PLAY" flashes on the display, press [▶] (PLAY) to restart from this position or [■] to clear it. (The position is also cleared when you turn the unit off or open the disc tray.)	
Pause	Press [⏸]. Press again to restart.	
Skip	Press [◀◀] (backward) or [▶▶] (forward). The item and marker skips backward or forward only the number of times pressed.	
Search	Press [◀◀] (backward) or [▶▶] (forward). Press [▶] (PLAY) to restart play.	
Slow-motion	While paused, press [◀◀] (backward) or [▶▶] (forward). Press [▶] (PLAY) to restart play.	
Frame-by-frame	While paused, press [◀◀◀] (backward) or [▶▶▶] (forward). Press and hold to change in succession. Press [▶] (PLAY) to restart play.	
Marker	Press [MARKER]. To mark positions using on-screen menus → page 23.	
Erase RAM DVD-R	1 Press [ERASE]. 2 Press [◀] to select "Erase" or "Yes" and press [ENTER]. • On the main unit, press [◀◀/◀◀] and [ERASE]. A program, play list, scene etc., cannot be restored once it is erased. Make certain before proceeding.	
Notes	<ul style="list-style-type: none"> • On the main unit, press [◀◀/◀◀] or [▶▶/▶▶] to perform skip, and press and hold to perform search and slow-motion. • The speed of search and slow-motion increases up to 5 steps. • Slow-motion and frame-by-frame only work on moving pictures. • You can turn off the sound during search (→ page 39, Audio—PLAY × 1.3 & Audio during Search). <p>When playing Video CDs</p> <ul style="list-style-type: none"> • You cannot move backwards during slow-motion and frame-by-frame. 	

Auto power-off

The unit switches to standby after about 6 hours in the stop mode. You can turn this feature off or change the time to 2 hours (→ page 38, Set Up—Off Timer).

- When you play a disc with an audio-only track, the video from the previous disc may continue to be shown on the television.
- The screen saver may appear when you stop play. Press [■] again and you can use this unit's tuner to watch television.



Using the Direct Navigator

RAM DVD-R

A list of programs is created as you record them. You can use this list to find programs to watch.

1 Press [DIRECT NAVIGATOR].

The highlighted program plays in the background.

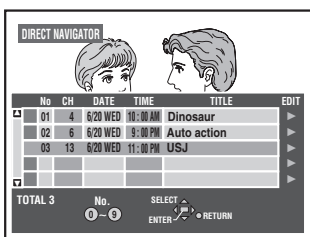

2 Press [▲, ▼] to select the program and press [ENTER].

You can also select programs with the numbered buttons.

e.g., "5": [0] → [5]
"15": [1] → [5]

To clear the program list

Press [DIRECT NAVIGATOR].

About the program list

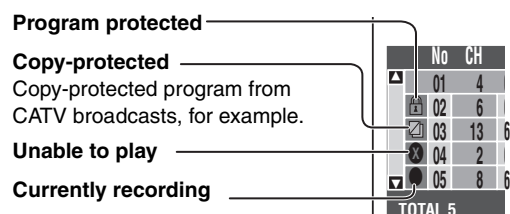

Changing audio during play

RAM DVD-A DVD-V VCD

To change the audio

Press [SHIFT]+[AUDIO].

■ While playing DVD-RAM or Video CD

LR→L→R

e.g., RAM "L R" is selected

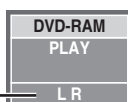

- When playing a SAP broadcast recorded DVD-RAM: MAIN↔SAP

For your reference

You can change the audio for the full images being played with simultaneous rec and play and Time Slip. RAM

■ While playing DVD-Audio or DVD-Video

You can change the audio channel number each time you press the buttons. This allows you to change things like the soundtrack language.



e.g., DVD-V English is selected.

Position Memory

(Effective only when the elapsed play time is displayed)

You can start play from a memorized position even after turning the unit off.

1 During play

Press [SHIFT]+[P.MEMORY].

The message "Position Memorized" appears on the television.

2 After switching the unit to standby and back on

Press [▶] (PLAY).

Play starts from the memorized position. (The position is cleared.)

Note

RAM

- Positions remain memorized even after the disc tray is opened.
- You cannot mark positions if the disc is write-protected.

DVD-R DVD-A DVD-V VCD CD MP3

- The position is cleared when you open the disc tray.

When a menu appears on the television

DVD-A DVD-V VCD

Press [▲, ▼, ◀, ▶] to select an item and [ENTER] to confirm.

Or, press the numbered buttons.

e.g., "5": [0] → [5]
"15": [1] → [5]

Press [TOP MENU] to show the top menu.

Press [MENU] to show a menu.

Press [RETURN] to show a menu. VCD

Note

- Discs continue to rotate while menus are displayed. Press [■] when you have finished viewing to preserve the unit's motor and your television screen.
- If "⊘" appears on the television, the operation is prohibited by the unit or disc.
- Functions available vary from disc to disc.

Starting play from a selected item

Press the numbered buttons.

e.g., "5": [0] → [5] MP3 "5": [0] → [0] → [5]
"15": [1] → [5] "15": [0] → [1] → [5]

Note

- This may not work with some discs.
- This works only when stopped with some discs (the screen saver is on the television).
- A group (DVD-A) or title (DVD-V) number can be specified while the screen saver is displayed.

e.g., DVD-A "5": [5]
DVD-V "5": [0] → [5]

Playing bonus groups DVD-A

Some discs contain bonus groups. If a password screen appears after selecting a group, enter the password with the numbered buttons and press [ENTER]. Refer also to the disc's jacket.



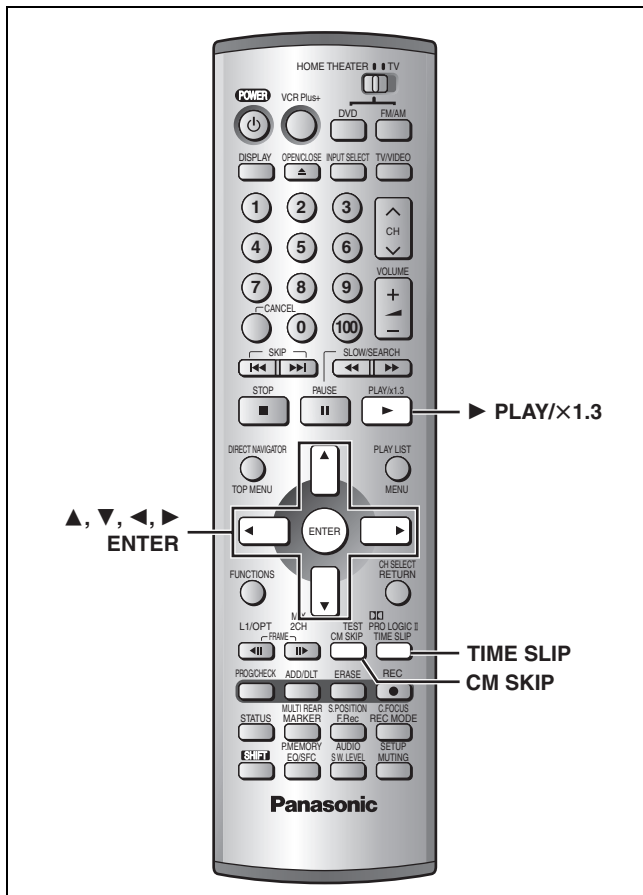

Selecting an amount of time to skip— Time Slip

RAM DVD-R

- 1 During play
Press [TIME SLIP].

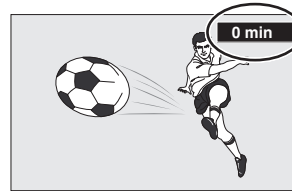

- 2 Within 5 seconds
Press [▲, ▼] to enter the time and then press [ENTER].

e.g., Go back to 5 minutes



Press to alter in one-minute units. Press and hold to alter in 10-minute units.

Quick View

RAM (Only with Dolby Digital)

You can increase the speed of play without disrupting the soundtrack.

- During play
Press and hold [▶] (PLAY/ ×1.3).

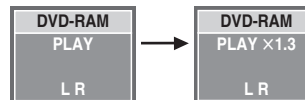

To return to normal speed

Press [▶] (PLAY/×1.3).

Note

- This is canceled if you perform operations to change the soundtrack, skip or pause.
- This does not work if the setting is “Off” in “PLAY ×1.3 & Audio during Search” (→ page 39).
- This does not work when recording is in XP or FR mode.

Skipping a minute forward—CM Skip

RAM DVD-R

Play restarts from approximately a minute later. Convenient when you want to skip commercials etc.

- During play
Press [CM SKIP].

Note

If the start of the next program is within one minute of the point you skipped from, play restarts from the beginning of that program.

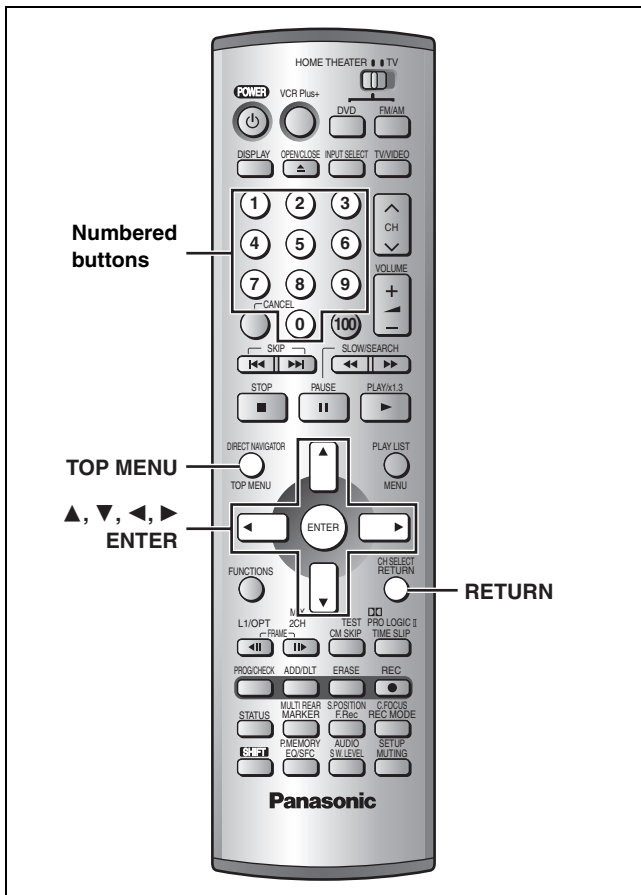

MP3

This unit can play MP3 files recorded on CD-R/RW with a computer. Files are treated as tracks and folders are treated as groups.

1 Press [TOP MENU].

Selected group number and name

G: Group no.
T: Track no. in the group
TOTAL: Selected track no./
 Total track no. in all
 groups

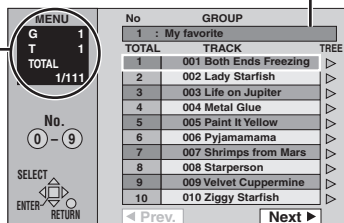

2 Press [▲, ▼] to select the track and press [ENTER].

Play continues to the last track in the last group.

- "▶" indicates the track currently playing.
- You can also select tracks with numbered buttons.
 e.g., "5": [0] → [5] → [5]
 "15": [0] → [1] → [5]

To show other pages

Press [▲, ▼, ◀, ▶] to select "Prev." or "Next" and press [ENTER]. After listing all the tracks in one group, the list for the next group appears.

To exit the file list

Press [TOP MENU].

Using the tree screen to find a group

While the file list is displayed

1 Press [▶] while a track is highlighted to display the tree screen.

Selected group no. / Total group no.

If the group has no track, "--" is displayed as group number.

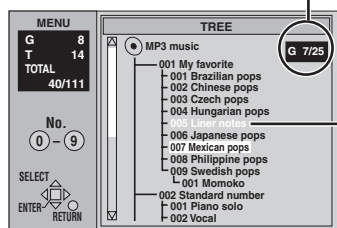

You cannot select groups that contain no compatible files.

2 Press [▲, ▼, ◀, ▶] to select a group and press [ENTER].

The file list for the group appears.

To return to the file list

Press [RETURN].

Note

- Discs must conform to ISO9660 level 1 or 2 (except for extended formats).
- This unit is compatible with multi-session but if there are a lot of sessions it takes more time for play to start. Keep the number of sessions to a minimum to avoid this.
- If you play a MP3 track that includes still picture data, it will take some time before the music itself starts playing and the elapsed time will not be displayed during this time. Even after the track starts, the correct play time will not be displayed.
- This unit is not compatible with ID3 tags or packet writing.
- Depending on recording some items may not be playable.
- Compatible sampling rate: 16, 22.05, 24, 32, 44.1 and 48 kHz
 Compatible compression rate: between 32 kbps and 320 kbps
- Maximum number of tracks and groups recognizable:
 999 tracks and 99 groups

Naming folders and files

- MP3 files must have the extension ".MP3" or ".mp3".
- At the time of recording, give folder and file names a 3-digit numeric prefix in the order you want them to play (this may not work at times).

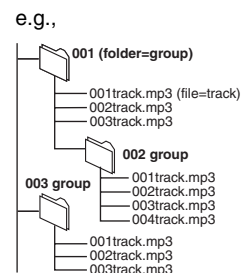

MPEG Layer-3 audio decoding technology licensed from Fraunhofer IIS and Thomson multimedia.

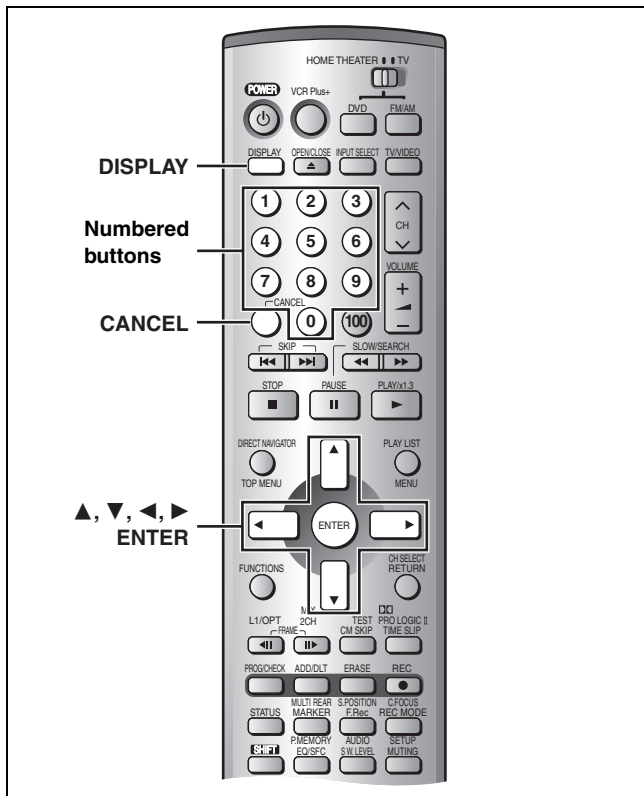

Common procedures

1 Press [DISPLAY].

e.g., DVD-RAM

Disc	Sound track	1	DD Digital	2/0 ch
Play	Subtitle		OFF	
Video	Audio channel		L R	
Audio				

Menu Item Setting

2 Press [▲, ▼] to select the menu and press [▶].

3 Press [▲, ▼] to select the item and press [▶].

4 Press [▲, ▼] to select the setting.

To clear the on-screen menus

Press [DISPLAY].

For your reference

- Some items can also be changed with the numbered buttons.
- Some items can be changed by pressing [ENTER].
- Depending on the condition of the unit (playing, stopped, etc.) and disc contents, there are some items that you cannot select or change.

A Soundtrack/Subtitle language

ENG: English	SVE: Swedish	CHI: Chinese
FRA: French	NOR: Norwegian	KOR: Korean
DEU: German	DAN: Danish	MAL: Malay
ITA: Italian	POR: Portuguese	VIE: Vietnamese
ESP: Spanish	RUS: Russian	THA: Thai
NLD: Dutch	JPN: Japanese	*: Others

Disc menu

Not available when playing CDs and MP3 discs.

e.g.,

DVD-RAM

Disc	Sound track	1	DD Digital	2/0 ch
Play	Subtitle		OFF	
Video	Audio channel		L R	
Audio				

Item	Content
Sound track	Soundtrack language DVD-A DVD-V See A below.
	Audio attribute RAM DVD-R DVD-A DVD-V See B below.
	Karaoke vocals, on and off (Karaoke DVD-V only) Solo: ON ↔ OFF Duet: OFF ↔ V1+V2 ↔ V1 ↔ V2
Subtitle	Subtitle language DVD-A DVD-V See A below.
	Subtitle on/off RAM DVD-R DVD-A DVD-V
Angle	Angle number DVD-A DVD-V
STILL-P Page	Still picture number DVD-A ●When "Return" is displayed Select "Return" and press [ENTER] to return to the default page. ●When "RANDOM" is displayed Select "RANDOM" and press [ENTER], the picture changes randomly each time you press [ENTER].
	Slide Show (Display only) DVD-A
	Audio channel RAM VCD (→ page 19)
PBC	Playback control on/off VCD Indicates whether menu play (playback control) is on or off.

For your reference

- When playing back recordings of SAP broadcasts, "1+1 ch" will be displayed.
- You may have to use the menus on the disc to make a change to selectable soundtracks, subtitles, and angles if they are recorded on the disc.
- If the subtitles overlap closed captions recorded on discs, turn the subtitles off.

Audio menu

DVD-A DVD-V

Disc	Dialog Enhancer	OFF
Play		
Video		
Audio		

Item	Content
Dialog Enhancer	(Dolby Digital, 3-channel or over only, including a center channel) The volume of the center channel is raised to make dialog easier to hear. ON ↔ OFF

B Audio attributes

- LPCM/PPCM/DDigital/DTS/MPEG: Signal type
k (kHz): Sampling frequency
b (bit): Number of bits
ch (channel): Number of channels
e.g.,
3/2 1ch
 1: Low frequency effect (not displayed if there is no signal)
 0: No surround
 1: Mono surround
 2: Stereo surround (left/right)
 1: Center
 2: Front left+Front right
 3: Front left+Front right+Center

Play menu

These functions work only when the elapsed play time is displayed.

e.g.,
DVD-RAM

Disc	Repeat play	OFF
Play	Marker	1-10 *****
Video		
Audio		

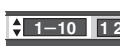
Item	Content	Remarks
Repeat play	<p>Each time you press [▲, ▼]:</p> <p>RAM DVD-R PRG: Program Track All Group PL: Play list (RAM) OFF OFF</p> <p>DVD-V VCD CD Chapter Track Title All OFF OFF</p> <p>To cancel: Select "OFF".</p>	<ul style="list-style-type: none"> You cannot use repeat play to repeat an entire DVD-Audio, DVD-Video, MP3 discs or all the play lists on a DVD-RAM. [ERASE] does not work while in repeat play mode. <p>If the Video CD has playback control</p> <ol style="list-style-type: none"> While stopped (the screen saver is on the television), press the numbered buttons to select a track (→ page 19). Select the repeat mode. 
Marker	<p>RAM DVD-R: 999 positions DVD-A DVD-V VCD CD MP3: 5 positions (The markers clear when you open the disc tray.)</p> <p>To mark a position Press [◀, ▶] to select an asterisk (*) and press [ENTER].</p> <p>To recall a marker Press [◀, ▶] to select a marker number and press [ENTER].</p> <p>To clear markers Press [◀, ▶] to select a marker number and press [CANCEL].</p>	<p>RAM DVD-R When marking positions 11 and above</p> <ol style="list-style-type: none"> Press [◀, ▶] to highlight "1-10". Press [▲, ▼] to select "11-20".  <p>Note</p> <ul style="list-style-type: none"> You cannot use this feature if: <ul style="list-style-type: none"> –you are using a play list. RAM –protection (cartridge → page 8, disc → page 32) is set (you can still recall the markers to play a position). RAM Markers on DVD-RAM and DVD-R are ordered by time, so marker numbers can change when you add and delete them.

Video menu

Not available when playing CDs and MP3 discs.

Disc	Picture	Normal
Play	MPEG-DNR	ON
Video		
Audio		

Item	Content
Picture	<p>Normal: Default setting</p> <p>Soft: Soft picture with fewer video artifacts</p> <p>Fine: Details are sharper</p> <p>Cinema: Mellows movies, enhances detail in dark scenes.</p> <p>User: You can make further adjustments. See below.</p>
MPEG-DNR	(When any item other than "User" is selected) You can change the 3D NR, block NR, and mosquito NR settings (→ below) to on or off. ON↔OFF

■ When you have set "TV Type" to "Aspect 4:3 & 480P" or "Aspect 16:9 & 480P" in SETUP (→ page 11)

Disc	Picture	Normal
Play	MPEG-DNR	ON
Video	Progressive	ON
Audio	Transfer	Auto 1

Item	Content
Progressive	<p>ON: Enables progressive output</p> <p>OFF: Disables progressive output</p>
Transfer (When progressive output is on)	<p>Select the method of conversion for progressive output to suit the type of material being played (→ page 51, Film and video).</p> <p>Auto1 (normal): For film material</p> <p>Auto2: For film material (the same as Auto1, but able to convert 30-frame-per-second progressive video.)</p> <p>Video: For video material</p>

■ When "User" is selected

Select "Detail picture adjustment". ("User" → [◀] → [▼] → [ENTER])

Disc	Pic 1/2	Contrast	◀ 0 ▶
Play	Det	Brightness	0
Video		Sharpness	0
Audio		Color	0

Page 1/2 of "Detail picture adjustment"

Contrast	Increases the contrast between light and dark parts of the picture (-7 to +7).
Brightness	Brightens the picture (0 to +15).
Sharpness	Adjust the sharpness of the edges of the horizontal lines (-6 to +6).
Color	Adjusts the shade of the picture's color (-7 to +7).

Press [ENTER] to enter the setting.

Press [▲] or [▼] until page 2/2 appears.

Disc	Pic 2/2	Gamma	0
Play	Det	3D NR	0
Video		Block NR	0
Audio		Mosquito NR	0

Page 2/2 of "Detail picture adjustment"

Gamma	Increases the brightness of the center ranges to improve detail and contrast in dark scenes (0 to +5).
3D NR	Reduces overall noise (0 to +4).
Block NR	Smooths block noise (0 to +3).
Mosquito NR	Reduces the smudging that appears around contrasting sections of the picture (0 to +3).

Press [ENTER] to enter the setting.

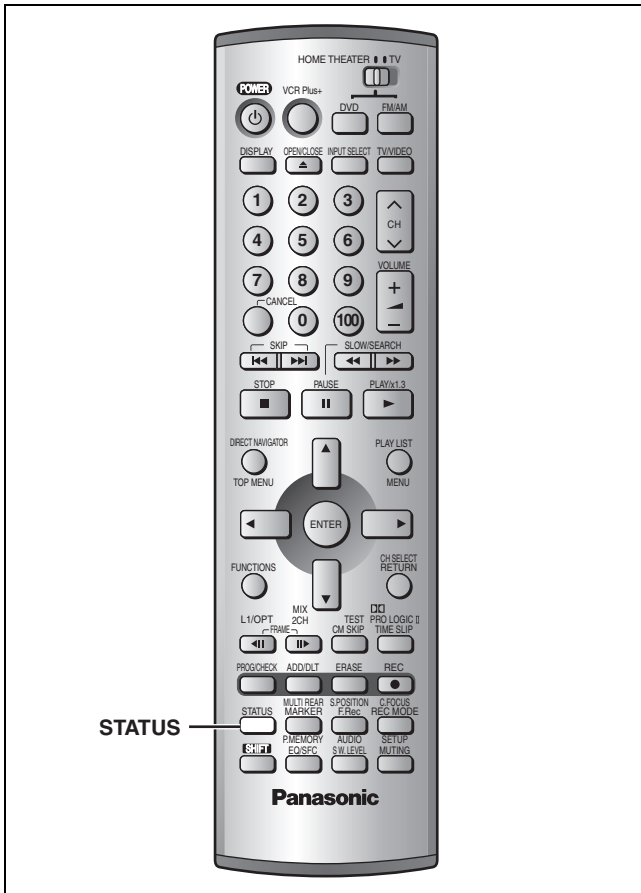

Displays appear on the television when you operate the unit to let you know what operation was performed and what condition the unit is in.

- You can change the setting in the SETUP menu so the first display does not appear automatically (⇒ page 39, Display—Status Messages).

Changing the information displayed

Press [STATUS].

The display changes each time you press the button.

e.g., DVD-RAM

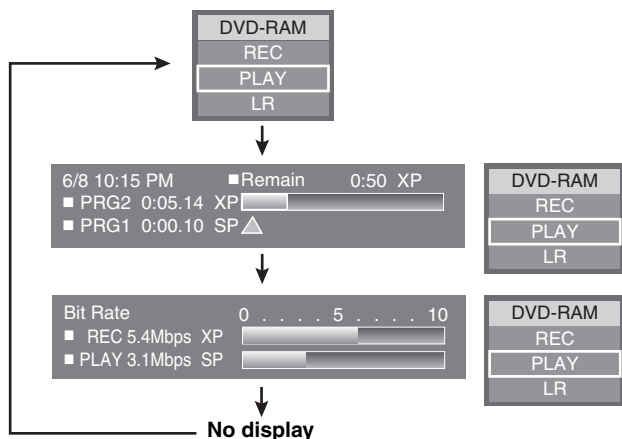

Display examples

e.g., DVD-RAM

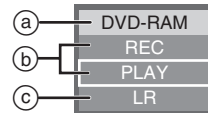

- a Disc indication
- b Current recording or play status/input channel and caption (if entered ⇒ page 41)

REC: Recording
PAUSE: Recording paused
PLAY: Playing
||: Playing paused
◀◀: Rewinding
▶▶: Fast forwarding
◀: Reverse slow-motion
▶: Slow-motion

- c Selected audio type

e.g., DVD-RAM

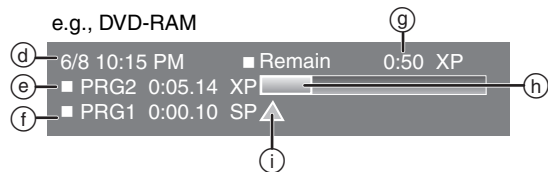

e.g., MP3

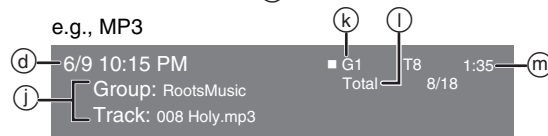

- d The current date and time
- e Elapsed recording time/recording mode
- f Elapsed play time of a program playing/mode at the time of recording
- g Available recording time and recording mode
- h Approximate volume of recording
- i Play position in the volume of recording
- j Selected group and track name
- k Selected group and track number
- l Selected track no./Total track no. in all groups
- m Elapsed play time of a track playing

e.g., DVD-RAM

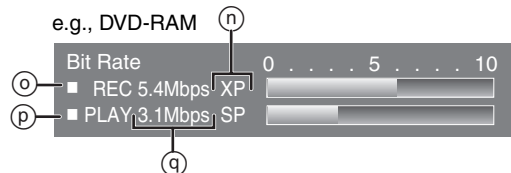

- n Recording mode or I/P/B display when paused (⇒ page 51)
- o Video bit-rate when recording
- p Video bit-rate when playing
- q Bit-rate display*
 Show as Mbps (Megabits per seconds) during play and recording, or kbit (kilobits) while paused.
 * The method of calculating bit-rate for recording and playing is different so there may be differences in the figures displayed. (Values are approximate.)

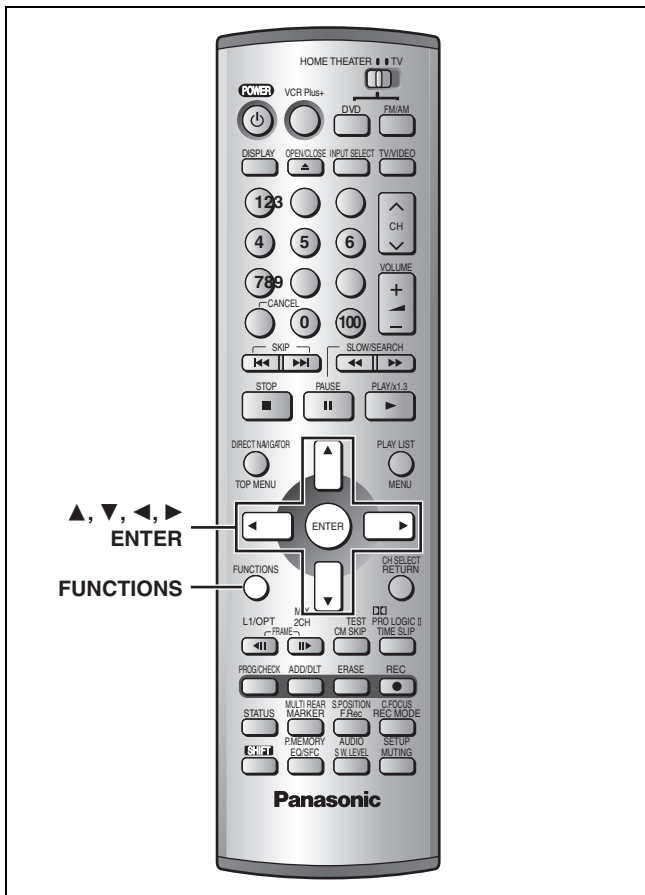

By using the FUNCTIONS window you may access the main functions quickly and easily.

1 While stopped

Press [FUNCTIONS].

e.g., DVD-RAM

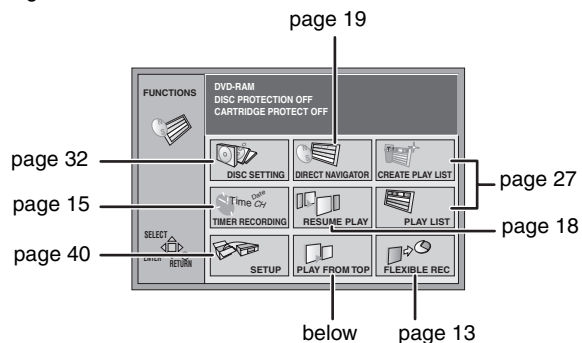

e.g., DVD-Video

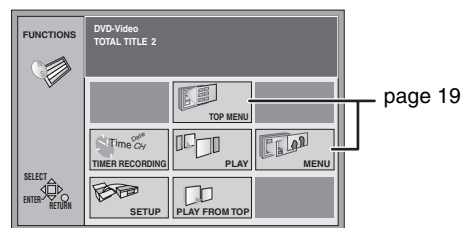

2 Press [▲, ▼, ◀, ▶] to select an item and press [ENTER].

PLAY FROM TOP

RAM DVD-R

Play will begin with the oldest program on the disc (Program 1).

DVD-A DVD-V

Play will avoid playing the introductory parts and begin playing the contents immediately. (The performance of this function varies from disc to disc.)

To clear the FUNCTIONS window

Press [FUNCTIONS].

Note

Functions displayed depend on the type of disc.

- Some items will be grayed out and cannot be selected if:
 - the disc is write protected/the disc is not formatted/there is nothing recorded on the disc.

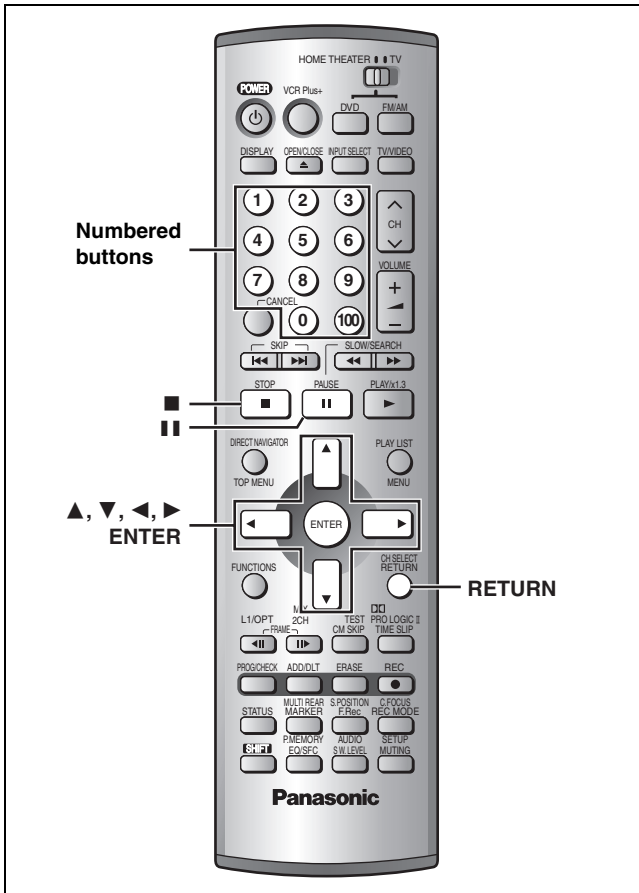

RAM DVD-R

This page shows how to enter text for:

- Program titles for timer recording (⇒ pages 14 and 15)
Program titles (⇒ page 30)
- Play list titles (⇒ page 28)
- Disc titles (⇒ page 32)

You can enter up to:

- 64 characters (DVD-RAM)
– A maximum of 44 characters is possible when inputting a title from the timer recording menu.
- 40 characters for a disc title (DVD-R)
- 44 characters for a program title (DVD-R)

Preparation

Release protection before proceeding. **RAM**
(Cartridge ⇒ page 8, disc ⇒ page 32, program ⇒ page 30)

- 1 After the Enter Title screen appears
Press [**▲**, **▼**, **◀**, **▶**] to select the character and press [**ENTER**].

Title field: shows the text you have entered

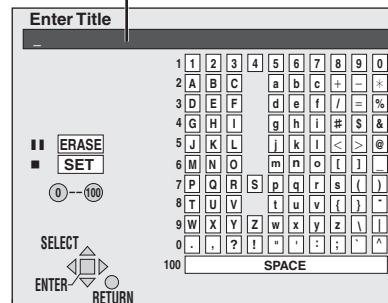

Repeat step 1 to enter other characters.

- 2 Press [**■**].

The title is entered and the screen disappears.

- You can also finish entering the title by selecting “SET” and pressing [**ENTER**].

To end input midway

Press [**RETURN**] (does not save any title information).

Using the numbered buttons to enter characters

e.g., entering the letter “R”

- ① Press [**7**] to move to the 7th row.
- ② Press [**7**] twice to highlight “R”.
- ③ Press [**ENTER**].

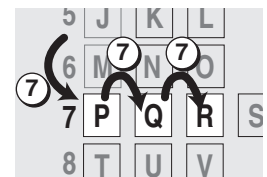

To erase a character

- ① Press [**▲**, **▼**, **◀**, **▶**] to select the character you want to erase in the title field.

- ② Press [**■**].

You can also erase characters by selecting “ERASE” and pressing [**ENTER**].

Note

- The full title is shown in the Properties screen (⇒ pages 28 and 30), but if you enter a long title, only part of it is shown in the program list or play list screen.
- If you enter a long title, only part of it is shown in the menu screen after finalization. **DVD-R**

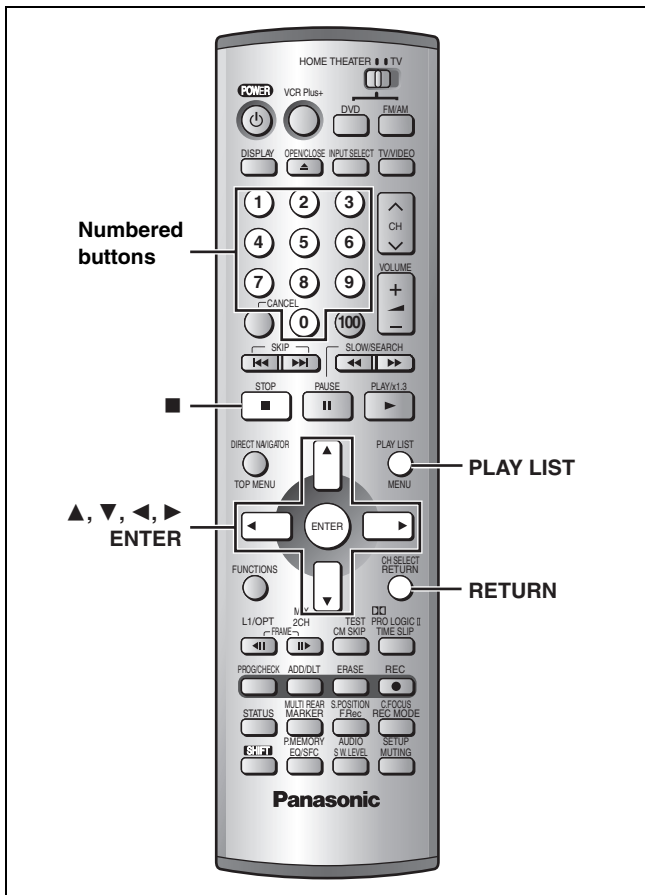

RAM
Specify start and end points to create scenes, then specify the order in which they are to be played. These scenes are not recorded separately so this doesn't use much capacity. You can create a maximum of 99 play lists and 999 scenes.

Creating play list

Preparation

Release protection before proceeding.
(Cartridge → page 8, disc → page 32)

- 1** While stopped
Press [PLAY LIST].
- 2** Press [▲, ▼] to select “--- --/--” and press [ENTER].
- 3** Press [ENTER] at the start point.

The length of the whole contents on the disc.

The location of the start point.

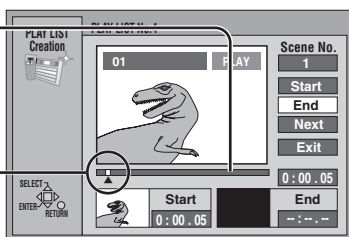

- You can use basic functions like fast forwarding and slow play (→ page 18).
- You can use the skip function to jump to another program (→ page 18).

4 Press [ENTER] at the end point.

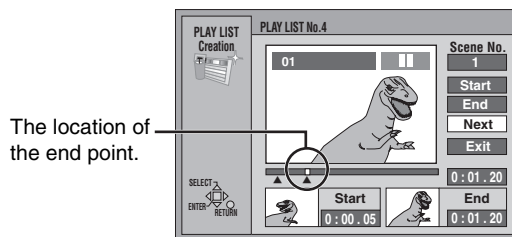

To specify another scene
Select “Next” and press [ENTER], then repeat steps 3 and 4.

5 Press [▲, ▼] to select “Exit” and press [ENTER].

The play list screen appears.

To clear the play list screen

Press [PLAY LIST].

To stop partway through

Press [RETURN].

For your reference

- You cannot specify an end point before a start point.
- You may not be able to specify points within 3 seconds of each other.
- Play pauses if the end of the last program on the disc is reached during this procedure.
- Depending on the state of recording, the actual number of play lists that can be recorded may be less than that specified in this manual.

Playing play lists

- 1** While stopped
Press [PLAY LIST].

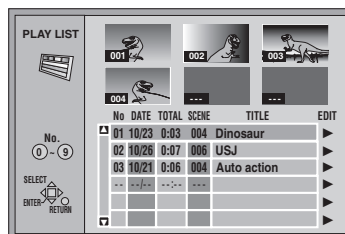

- 2** Press [▲, ▼] to select the play list and press [ENTER].

You can also select play lists with the numbered buttons.

e.g., “5”: [0] → [5]
“15”: [1] → [5]

To stop play list play

Press [■].

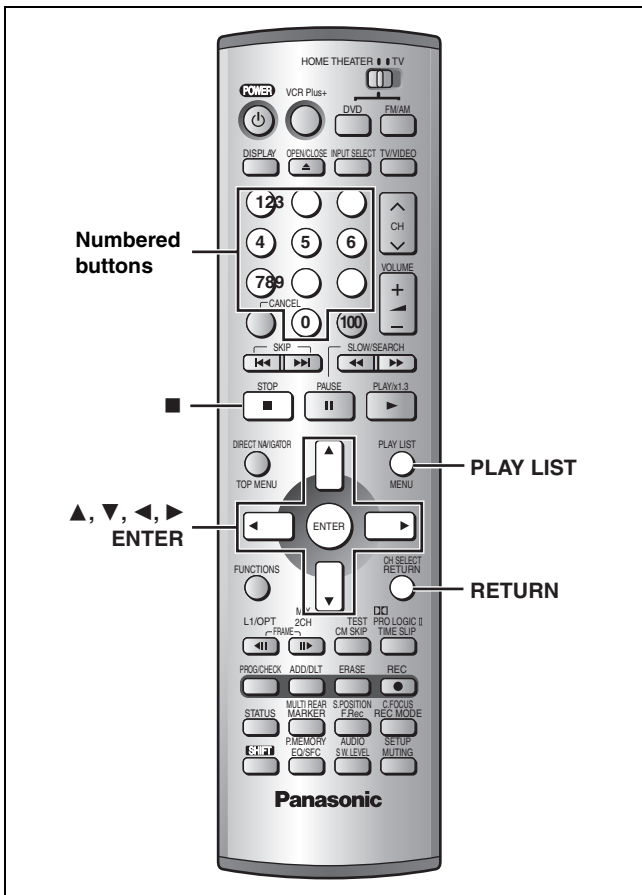

Play Scenes

5 Press [**▲**, **▼**, **◀**, **▶**] to select the scene and press [**ENTER**].

The scene you select is played.

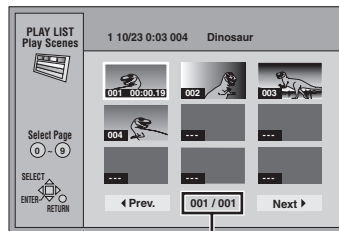

Page no./Total page no.

To show scene 10 and later

Press [**▲**, **▼**, **◀**, **▶**] to select “Next” and press [**ENTER**].

• You can also select a page of scenes with the numbered buttons.

e.g., “5”: [0] → [0] → [5]
 “15”: [0] → [1] → [5]

To stop scene play

Press [**■**].

To clear the scene list

Press [**RETURN**].

PL Copy

5 Press [**◀**] to select “Copy” and press [**ENTER**].

The copied play list appears at the bottom of the list.

PL Erase

5 Press [**◀**] to select “Erase” and press [**ENTER**].

The play list is erased.

Enter Title

Entering text (→ page 26)

Properties

Play list information (e.g., time and date) is shown.

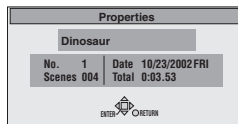

RAM

Common procedures

Preparation

Release protection before proceeding with “Edit Scenes”, “PL Copy”, “PL Erase” or “Enter Title”.

(Cartridge → page 8, disc → page 32)

- 1** While stopped
Press [**PLAY LIST**].
- 2** Press [**▲**, **▼**] to select the list.
- 3** Press [**▶**] so the submenu appears.

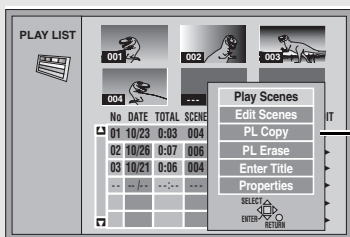

4 Press [**▲**, **▼**] to select the item and press [**ENTER**].

To clear the play list or scene list screen

Press [**PLAY LIST**].

To stop set up process

Press [**RETURN**].

Note

Once a play list or play list scene has been erased, it is irretrievable. Check carefully before proceeding.

Edit Scenes

- 5 Press [◀, ▶] to select the item (Add, Move, Re-edit or Erase) and press [ENTER].**

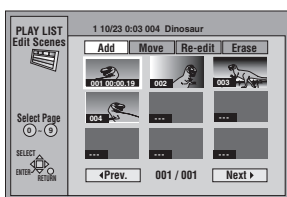

To show scene 10 and later

Press [▲, ▼, ◀, ▶] to select "Next" and press [ENTER].

You can also select a page of scenes with the numbered buttons.

e.g., "5": [0] ⇒ [0] ⇒ [5]
 "15": [0] ⇒ [1] ⇒ [5]

Add (maximum of 999 scenes)

- 6 Press [▲, ▼, ◀, ▶] to select the place where you want to add the scene and press [ENTER].**
- 7 Press [ENTER] at the start point of the scene.**



- 8 Press [ENTER] at the end point of the scene.**

To add other scenes

Press [▲, ▼] to select "Next" and press [ENTER], then repeat steps 6–8.

- 9 Press [▲, ▼] to select "Exit" and press [ENTER].**

The new scene is inserted before the highlighted scene.

Move

- 6 Press [▲, ▼, ◀, ▶] to select the scene and press [ENTER].**
- 7 Press [▲, ▼, ◀, ▶] to select the place where you want to move the scene to and press [ENTER].**

The scene is moved and inserted before the highlighted scene.

To move other scenes

Repeat steps 6 and 7.

Note

- You can use basic functions like fast forwarding and slow play (⇒ page 18).
- You can use the skip function to jump to another program (⇒ page 18).
- You cannot specify an end point before a start point.
- You may not be able to specify points within 3 seconds of each other.
- Play pauses if the end of the last program is reached during this procedure.
- Depending on the state of recording, the actual number of play lists or scenes that can be recorded may be less than that specified in this manual.
- You cannot edit still picture images.

Re-edit

- 6 Press [▲, ▼, ◀, ▶] to select the scene and press [ENTER].**
- 7 Press [ENTER] at the start point of the scene.**



- 8 Press [ENTER] at the end point of the scene.**

To re-edit other scenes

Press [▲, ▼] to select "Prev." or "Next" and press [ENTER], then repeat steps 6–8.

- 9 Press [▲, ▼] to select "Exit" and press [ENTER].**

The re-edited scene replaces the old one.

Erase

- 6 Press [▲, ▼, ◀, ▶] to select the scene and press [ENTER].**
- 7 Press [◀] to select "Yes" and press [ENTER].**

The selected scene is erased from the play list.

To erase other scenes

Repeat steps 6 and 7.

Note

The play list itself is erased if you erase all the scenes in it.

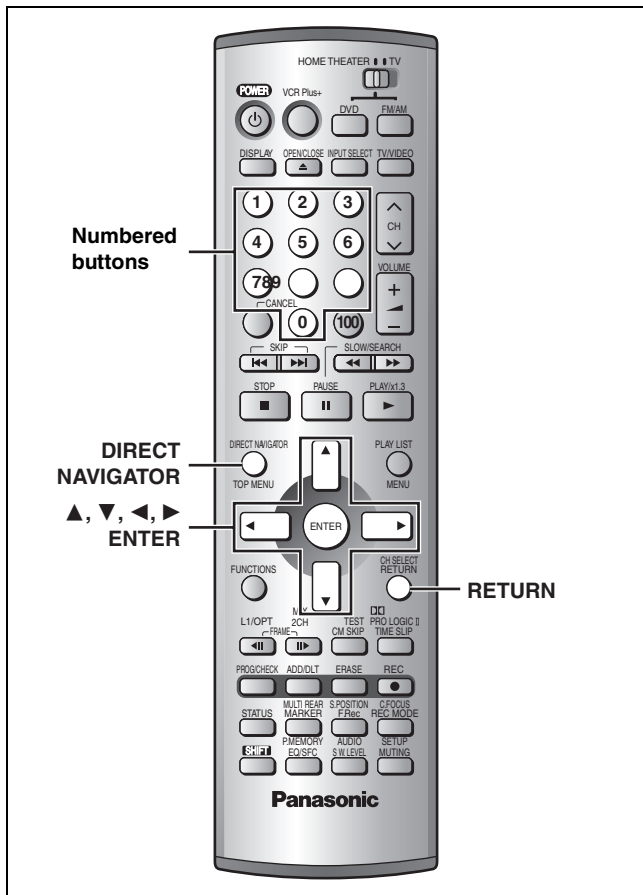

Erase Program

RAM DVD-R

5 Press [**◀**] to select “Erase” and press [**ENTER**].

The program is erased.

Note

- The disc’s available recording time may not increase after erasing short programs.
- Computer data cannot be erased.
- The available recording time on DVD-R does not increase when you erase programs.

Enter Title

RAM DVD-R

Entering text (→ page 26)

Properties

RAM DVD-R

Program information (e.g., time and date) is shown.



Common procedures

Preparation

Release protection before proceeding with “Erase Program”, “Enter Title”, “Protection”, “Shorten Segment” or “Divide Program”. **RAM**

(Cartridge → page 8, disc → page 32)

- 1** Press [**DIRECT NAVIGATOR**].
- 2** Press [**▲, ▼**] to select the program.
You can also select programs with the numbered buttons.
e.g., “5”: [0] → [5]
- 3** Press [**▶**] so the submenu appears.

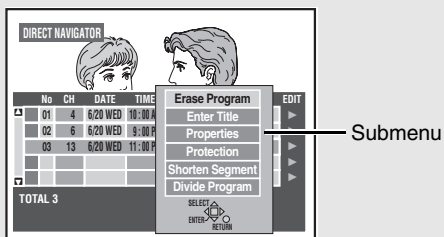

- 4** Press [**▲, ▼**] to select the item and press [**ENTER**].

To clear the program list

Press [**DIRECT NAVIGATOR**].

To stop set up process

Press [**RETURN**].

Note

Once a program is erased, divided, or a segment is shortened, it cannot be restored to its original state. Make certain before proceeding.

- Once a program is erased or a segment is shortened, the play list which was created from that program is also erased.

Protection

RAM

If set, this will protect the program from accidental erasure.

- 5** Press [**◀**] to set protection and press [**ENTER**].

The lock symbol appears when the program is write-protected.

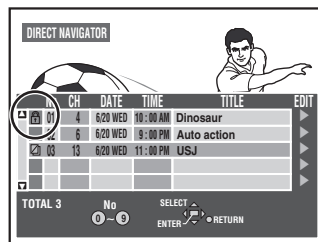

Shorten Segment

RAM

- 5 Press [ENTER] at the start point of the section you want to erase.

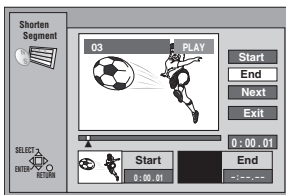

- 6 Press [ENTER] at the end point of the section you want to erase.

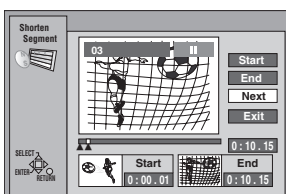

To continue using Shorten Segment

- 1 Press [▲, ▼] to select “Next” and press [ENTER], then press [◀] to select “Erase” and press [ENTER].
- 2 Repeat steps 5 and 6.

- 3 Press [▲, ▼] to select “Exit” and press [ENTER].

- 4 Press [◀] to select “Erase” and press [ENTER].

Segments are erased from the start to end point.

Note

- You can use basic functions like fast forwarding and slow play (→ page 18).
- Play pauses if the end of the program is reached during this procedure.
- You cannot specify an end point before a start point.
- You may not be able to specify points within 3 seconds of each other.
- You cannot specify points on still pictures in the program.
- The disc's available recording time may not increase after erasing short segments.

Divide Program

RAM

Select a point at which to divide the program into two.

- 5 Press [ENTER] at the point you want to divide the program.

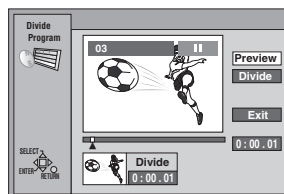

To confirm the division point

Press [▲, ▼] to select “Preview” and press [ENTER]. (Play will begin from a point 10 seconds prior to and after the division point.)

To change the division point

Restart play and press [▲, ▼] to select “Divide”, then press [ENTER] at the point you want to change.

- 6 Press [▲, ▼] to select “Exit” and press [ENTER].

- 7 Press [◀] to select “Divide” and press [ENTER].

The program is divided.

Note

- The divided programs retain the title and CPRM property (→ page 51) of the original program.
- A very small portion of the recording preceding the division point may be lost.
- It is not possible to carry out Divide Program in the following cases:
 - when the program is extremely short.
 - when the total number of programs is more than 99.

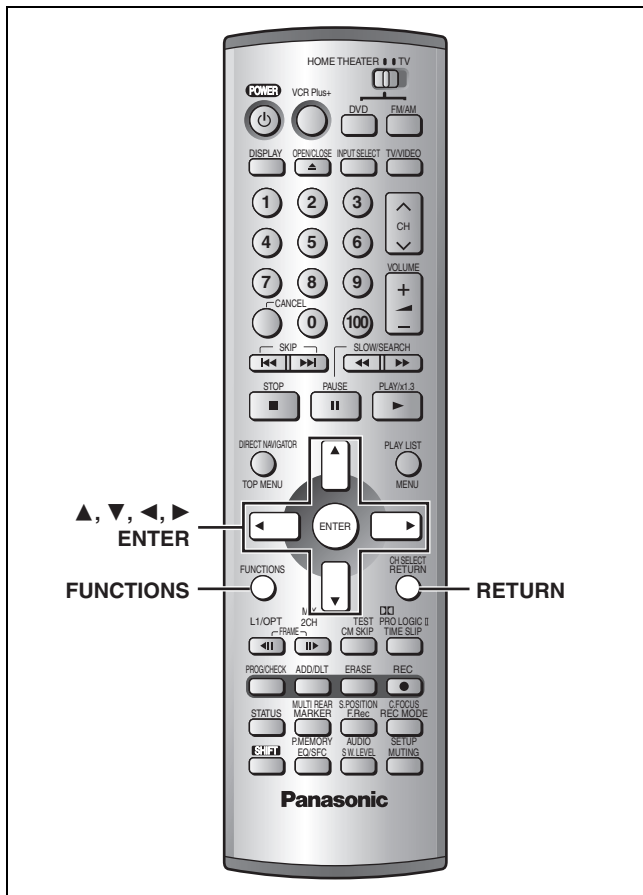

Enter Title

RAM DVD-R

Entering text (→ page 26)

Disc Protection

RAM

If set, this will protect the disc from accidental erasure.

4 Press [◀] to set disc protection and press [ENTER].

The lock symbol appears closed when the disc is write-protected.

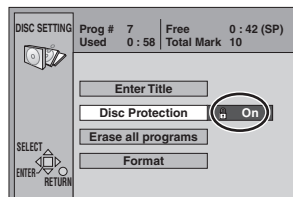

Erase all programs

RAM

4 Press [◀] to select “Yes” and press [ENTER].

5 Press [◀] to select “Start” and press [ENTER].

All programs and play lists are erased.

Note

- Computer data cannot be erased.
- Erase does not work if one or more programs are protected.

Common procedures

Preparation

Release protection before proceeding with “Enter Title”, “Disc Protection”, “Erase all programs” or “Format”. **RAM** (Cartridge → page 8, disc → right, program → page 30)

- 1 While stopped
Press [FUNCTIONS].
- 2 Press [▲, ▼, ◀, ▶] to select “DISC SETTING” and press [ENTER].
e.g., DVD-RAM

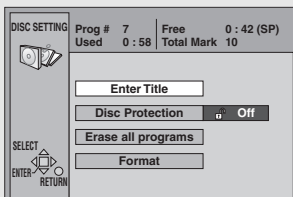

- 3 Press [▲, ▼] to select the item and press [ENTER].

To stop set up process

Press [RETURN].

Note

Once all programming has been erased or the disc has been formatted, the contents cannot be restored. Check carefully before proceeding.

- Once a program is erased the play list which was created from that program is also erased.

Format

RAM

Some DVD-RAM are unformatted. Format them before using them in this unit. Formatting also allows you to erase the entire contents of a disc.

Preparation

If the disc is dirty, clean it with the recommended cleaner (→ page 53) before formatting.

- 4 Press [◀] to select “Yes” and press [ENTER].**
- 5 Press [◀] to select “Start” and press [ENTER].**
Formatting starts.
 - A message appears when formatting is finished.
- 6 Press [ENTER] to complete the procedure.**

To stop formatting

Press [RETURN].

- You can cancel formatting if it takes more than 2 minutes. The disc must be reformatted if you do this.

Note

- **Do not disconnect the AC power supply cord while the message “Formatting the disc” is on the television. This can render the disc unusable.**
- Formatting normally takes a few minutes, however it may take up to a maximum of 70 minutes.
- The contents on the disc are erased when you format it even if you have set program or disc protection.
- It may not be possible to use a disc on this unit if you cannot format it.
- Formatting cannot be performed on DVD-R or CD-R/RW.
- Formatting erases all contents on the disc, including computer data.

Finalize

DVD-R (DVD-R recorded on this unit only)

You can play DVD-R on compatible DVD players by finalizing them on this unit, effectively making them into DVD-Video that complies with DVD-Video standards.

- 4 Press [◀] to select “Yes” and press [ENTER].**
- 5 Press [◀] to select “Start” and press [ENTER].**
Finalizing starts.
 - A message appears when finalizing is finished.
- 6 Press [ENTER] to complete the procedure.**

Note

- **Do not disconnect the AC power supply cord while the message “Finalizing the disc” is on the television. This will render the disc unusable.**
- Finalizing takes up to 15 minutes.

After finalizing..

- You cannot record or perform editing such as giving titles and erasing programs.
 - Programs longer than 5 minutes are divided into about five-minute chapters.
 - There is a pause of several seconds between program segments.
 - These DVD-R can be played on other Panasonic DVD players, but this is not guaranteed. Play may not be possible due to the player you are using, the DVD-R, or the condition of the recording. Play the disc using this unit if you experience problems with other equipment.
- Visit Panasonic's homepage for more information about DVDs.
<http://www.panasonic.com/playDVD-R>

For your reference

The markers you entered (→ pages 18 and 23) will be lost.

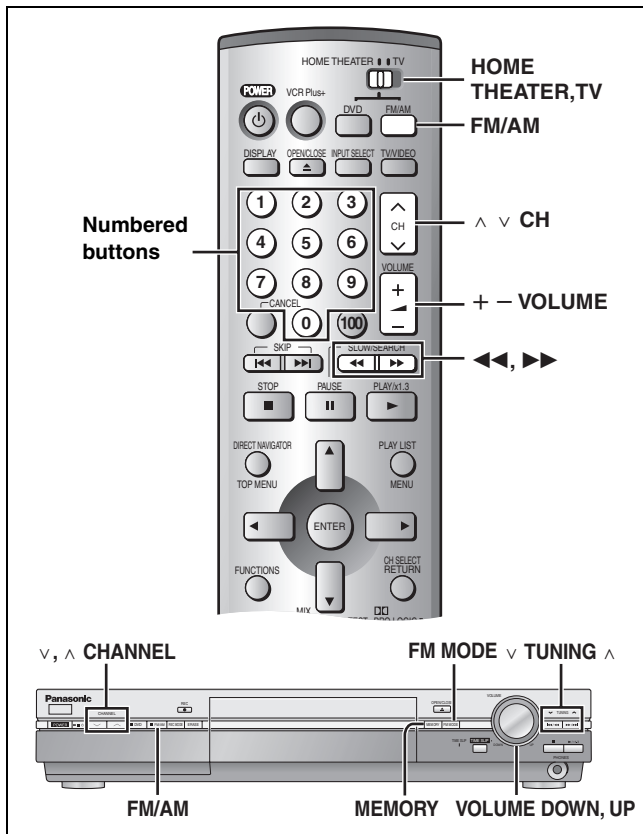

- Preparation**
- Switch [HOME THEATER, TV] to "HOME THEATER".
 - Press [FM/AM] to select "FM" or "AM" as the source.

Manual tuning

- 1 Press [∇ TUNING] or [TUNING \wedge] to select the frequency of the required station.

Remote control: Press [\lll] or [\ggg].
 TUNED: Displayed when a radio station is tuned.
 ST: Displayed when a stereo FM broadcast is being received.



Press and hold [∇ TUNING] or [TUNING \wedge] ([\lll] or [\ggg] on the remote control) until the frequency starts scrolling to start automatic tuning. Tuning stops when a station is found.

- 2 Adjust the volume.

Main unit only

■ If noise is excessive

Press [FM MODE].

Each time you press the button:

FM: Changes between stereo and forced monaural.

AM: BP1 \leftrightarrow BP2 (BP=Beat Proof)

Select either BP1 or BP2, whichever receives better reception.

The FM mode is canceled when you change the frequency.

■ FM frequency step

The step is factory-set to 0.2 MHz, but you can change it to receive broadcasts allocated 0.1-MHz steps.

- 1 Press [FM/AM] to select "FM".
- 2 Press and hold [FM/AM].

After a few seconds the display changes to show the current minimum frequency. Continue to hold the button down. The minimum frequency changes and the step is changed.

To return to the original step, repeat the above steps.

Note

Any FM and AM frequencies preset in channels will be initialized by this procedure. Preset them again.

Preset tuning

Preset channels to make selection simple.
 Up to 12 stations can each be set in the FM and AM bands.

Automatic presetting

Main unit only

- 1 Tune to "FM 87.9" MHz or "FM 87.5" MHz (\Rightarrow left).

- 2 Press and hold [MEMORY].

Release the button when "AUTO" is displayed.

The tuner presets all the stations it can receive into the channels in ascending order.
 "SET OK" is displayed when the stations are set. The last station to be set is then played.

- 3 Tune to "AM 520" kHz.

Repeat step 2 for AM automatic presetting.

"ERROR" is displayed

Presetting was unsuccessful. Preset manually.

Manual presetting

Main unit only

- 1 Tune to the station (\Rightarrow left).

- 2 Press [MEMORY].

- 3 While "MEMO" is flashing

Press [∇ , \wedge CHANNEL] to select a channel and press [MEMORY].



The station occupying a channel is erased if another station is preset in that channel.

Selecting channels

- 1 Press [FM/AM] to select "FM" or "AM".

- 2 Press the numbered buttons or [\wedge ∇ CH] to select the channel.

e.g., "2": [0] \Rightarrow [2]
 "12": [1] \Rightarrow [2]



Note

If there is nearby electrical interference during auto tuning the frequency may come to a halt without locating a channel. Turn off the power of the nearby electrical equipment.

Optional FM antenna connection

Use FM outdoor antenna if radio reception is poor.

Note

- Disconnect the outdoor antenna when the unit is not in use.
- Do not use the outdoor antenna during an electrical storm.

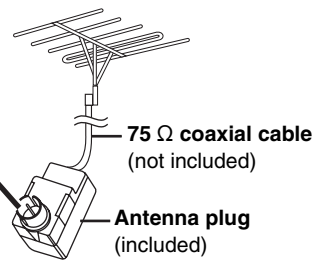
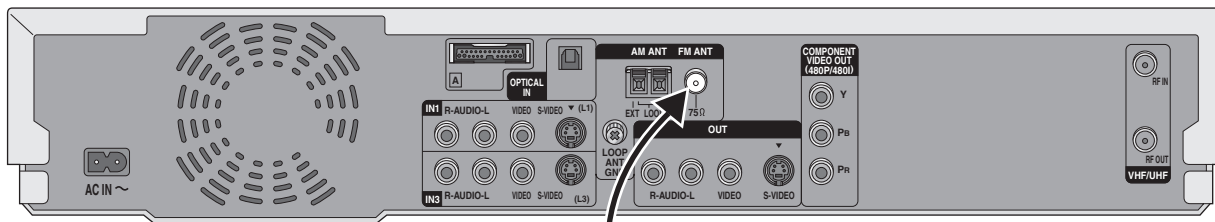

FM outdoor antenna (Using a television antenna)

- Disconnect the FM indoor antenna.
 - The antenna should be installed by a competent technician.
- Rework your outdoor antenna's 75 Ω coaxial cable as follows.

- ① **Remove a piece of the outer vinyl insulator.**

10 mm ($\frac{13}{32}$ ")
Peel back
7 mm ($\frac{9}{32}$ ")
- ② **Carefully pull the tabs apart to remove the cover.**
- ③ **Install the coaxial cable.**
Clamp the cable conductor, and wind it on so that it does not contact anything else.

Clamp with pliers
- ④ **Attach the cover.**

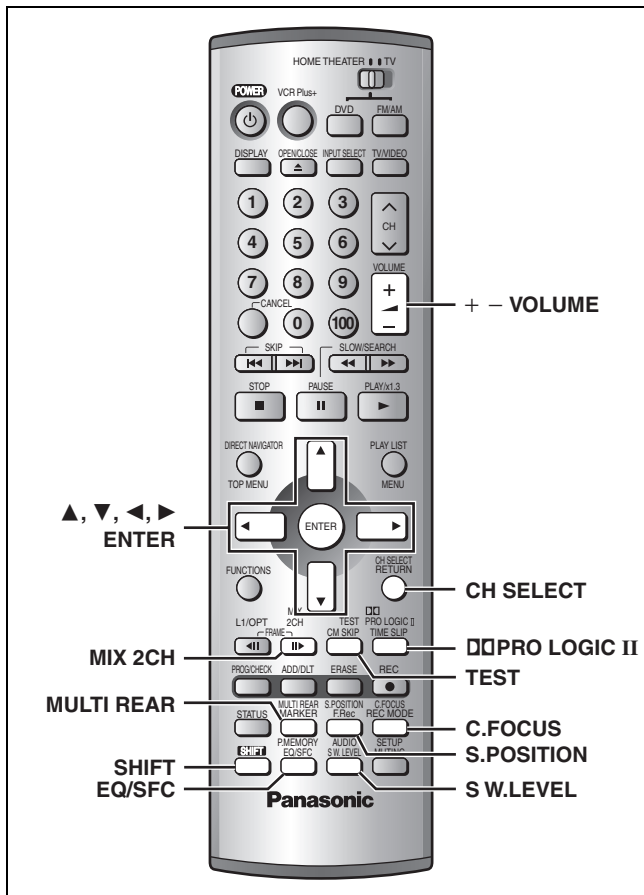

- When connected with headphones, the following sound field systems cannot be used. (Excluding Sound Field Control)
- You may experience a reduction in sound quality when these sound field systems are used with some sources. If this occurs, turn the sound field system off.

Dolby Pro Logic II

The Dolby Pro Logic II processor works not only on sources recorded with Dolby Surround, but also on any stereo source.

1 Press [SHIFT]+ [DOLBY LOGIC II].

Each time you do this:
OFF → MOVIE → MUSIC → PANORAMA



- MOVIE:** Use this mode when playing movie software, especially videotapes, recorded in Dolby Surround.
- MUSIC:** Adds surround effects to stereo sources.
- PANORAMA:** Sound is spread out more so you feel like you are surrounded by music.

2 Play a Dolby Surround or stereo source.

To cancel
Select "Dolby PLII OFF".

Note
This does not work when playing multi-channel Dolby Digital.

Dolby Digital and DTS

- Dolby Digital and DTS are digital encoding systems used on DVD to carry surround sound. Both were originally developed for use in cinemas.
- This unit automatically recognizes and decodes these systems.

Software encoded with Dolby Digital can be identified with this mark.



Software encoded with DTS can be identified with this mark.



Play a Dolby Digital or DTS source.

The Dolby Digital or DTS indicator lights.



To down-mix Dolby Digital or DTS (multiple-channel) signals to 2 channels

Press [SHIFT]+[MIX 2CH].



To cancel, press [SHIFT]+[MIX 2CH] again.

When "D.MIX" flashes on the display DVD-A

The DVD-Audio contains multiple-channel signals that cannot be down-mixed.

Sound Field Control

Press [EQ/SFC] to select a setting.



Each time you press the button:

- FLAT:** Canceled (no effect is added) (factory preset).
- HEAVY:** Adds punch to rock.
- CLEAR:** Clarifies higher sounds.
- SOFT:** For background music.
- DISCO:** Reverberates sound to make you feel like you were in a disco.
- LIVE:** Makes vocals more alive.
- HALL:** Expands sound to make you feel like you were in a hall.

To check the current setting
Press [EQ/SFC].

Center Focus

You can make the sound of the center speaker seem like it is coming from within the television.

Press [SHIFT]+[C.FOCUS].

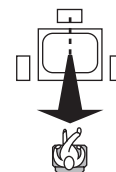

Each time you do this:
CENTER FOCUS ON → CENTER FOCUS OFF

- This will have less effect when Dolby Pro Logic II is turned on.



Virtual Rear Surround

This mode is useful if you have to place your surround speakers near the front speakers due to the layout of your room. This mode makes it seem like the sound from the surround speakers is coming from behind you.

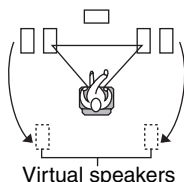

Press and hold **[SHIFT]+[MULTI REAR]** for more than 5 seconds.

Each time you do this:
V.R.S ON ↔ V.R.S OFF



Multi Rear Surround

This mode makes it seem like sound is coming from multiple rear surround speakers virtually when connected with surround speakers.

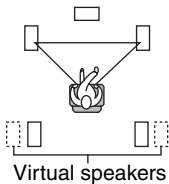

Press **[SHIFT]+[MULTI REAR]**.

Each time you do this:
M.R.S ON ↔ M.R.S OFF



Seat position

Using this function makes you feel like you are sitting in the ideal seating position (in the center of the circle formed by the speakers), even if you cannot due to the layout of your room.

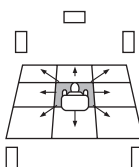

1 Press **[SHIFT]+[S.POSITION]**.



2 While "SEAT POSITION" is displayed Press **[▲, ▼, ◀, ▶]** to select a position.



To cancel

Press **[SHIFT]+[S.POSITION]** again.

Note

While virtual rear surround is on, the seat position is changed in three horizontal steps.

Adjusting the bass

Press **[S W.LEVEL]**.



Each time you press the button:
SUB W 1 → SUB W 2 → SUB W 3 → SUB W 4 (factory preset)

Speaker level adjustments

Adjust the level of the speakers so they are the same apparent level as the front speakers where you would normally be sitting and listening. (L, R → below, Balance)

Preparation

- Dolby Digital and DTS: Turn off the other sound field systems.
- Dolby Pro Logic II: Press **[SHIFT]+[DOLBY PRO LOGIC II]**.

1 Press **[SHIFT]+[TEST]** to output a test signal.

Lch: Front left
Cch: Center
Rch: Front right
RSch: Right surround
LSch: Left surround

2 Press **[VOLUME +]** or **[-]** to set the volume level normally used for listening.

3 Press **[▲]** (to increase) or **[▼]** (to decrease).

L, R: (→ below, Balance)
C, RS, LS: -6 dB to +6 dB

To stop the test signal, press **[SHIFT]+[TEST]** again.

■ To adjust speaker level during play

1 Press **[SHIFT]+[CH SELECT]** to select the speaker.

L R → Cch → RSch → LSch → SWch

SW: Subwoofer

- You can only adjust SW if there is output from the subwoofer channel.

2 Press **[▲]** (to increase) or **[▼]** (to decrease).

L, R: (→ below, Balance)
C, RS, LS: -6 dB to +6 dB
SW: -6 dB to +6 dB

Balance

You can adjust the balance of the front speakers.

- 1** Press **[SHIFT]+[CH SELECT]** to select "L R".
- 2** Press **[◀, ▶]** to adjust the "L", "R" balance.

Summary of settings

This chart shows the initial settings for this unit. See pages 40–43 for details on menu operation.

• Underlined items are the factory presets.

Tabs	Menus	Options
Channel	Antenna System (⇒ page 40)	•TV • <u>CATV</u>
	Auto Channel Setting (⇒ page 40)	
	Preset Channel Caption (⇒ page 41)	
	Manual Channel Caption (⇒ page 41)	
	VCR Plus+ CH Setting (⇒ page 10)	
Set Up	Off Timer Select how long the unit remains on when it is not being used.	•2 hr • <u>6 hr</u> •Off
	Remote Control Code (⇒ page 42)	• <u>Set Code 1</u> •Set Code 2 •Set Code 3
	Auto Clock Setting (⇒ page 43)	
	Manual Clock Setting (⇒ page 43)	
	Time Zone Adjust (⇒ page 43)	•-1 • <u>0</u> •+1
	Re-initialize Setting This returns all values in the SETUP menus, except for the clock, channel settings, ratings level, and display language, to the default settings.	•Yes • <u>No</u>
Disc (Playing a DVD disc)	Audio Choose the audio language.	Some discs start in a certain language despite any changes you make here.
	Subtitle Choose the subtitle language.	
	Menus Choose the language for disc menus.	
	Ratings Set a ratings level to limit DVD-Video play. The password screen is shown when you select levels 0 to 7. To enter a password 1 Input a 4-digit password with the numbered buttons. • If you enter a wrong number, press [CANCEL] to erase it. • Do not forget your password. 2 Press [ENTER]. • The lock symbol appears closed to show the rating is locked. 3 Press [ENTER] to confirm the 4 digits.	<ul style="list-style-type: none"> •<u>English</u> •French •Spanish •Original: The original language of each disc will be selected. •Other *****: Input a code (⇒ page 50).
		<ul style="list-style-type: none"> •<u>Automatic</u>: If the language selected for "Audio" is not available, subtitles of that language will automatically appear if available on that disc. •English •French •Spanish •Other ***** •<u>English</u> •French •Spanish •Other *****
		<p>Setting ratings (When level 8 is selected)</p> <ul style="list-style-type: none"> 8 <u>No Limit</u>: All DVD-Video can be played. 1 to 7: Prohibits play of DVD-Video with corresponding ratings recorded on them. 0 Lock All: Prohibits play of all DVD-Video. <hr style="border-top: 1px dashed black;"/> <p>Changing ratings (When level 0–7 is selected)</p> <ul style="list-style-type: none"> •Unlock Recorder •Change Password •Change Level •Temporary Unlock
		If you insert a DVD-Video that exceeds the ratings limit you set, a message appears on the television. Follow the on-screen instructions.
	DVD-Video mode Select how to play pictures contained on some DVD-Audio. The setting returns to "Off" when you change the disc or turn the unit off.	<ul style="list-style-type: none"> •<u>On</u>: You can play DVD-Video content on DVD-Audio. •Off: DVD-Audio are played as DVD-Audio.
Video	3-D Y/C Separation	<ul style="list-style-type: none"> •<u>On</u>: Reduces noise for recording by separating the luminance (Y) and color (C) signals received from the television station. •Off: Reduces the ghosting that occurs when recording fast moving images.
	Hybrid VBR Resolution	<ul style="list-style-type: none"> •<u>Automatic</u>: Video compression is automated providing efficient recording. •Fixed: Video compression is fixed when recording providing smooth video play.
	Still Mode Select the type of picture shown when you pause play.	<ul style="list-style-type: none"> •<u>Automatic</u> •Field: Less blurred field stills are shown. Select if jittering occurs when "Automatic" is selected. •Frame: Sharper frame stills are shown. Select if small text or fine patterns cannot be seen clearly when "Automatic" is selected.

Continued on next page.

Tabs	Menus	Options
Video	Seamless Play Turn seamless play on or off on discs with play lists. ●Seamless Play does not work with programs recorded in LPCM or when using Quick View.	● <u>On</u> : The scenes in play lists are played seamlessly. This may cause shifting of the points where scenes change. Some play lists cannot be played seamlessly. ● <u>Off</u> : The points where scenes in play lists change are played accurately, but the picture may freeze for a moment.
	Black Level Control Select normal, lighter or darker for adjusting the black level control to the desired setting for picture enhancement.	● <u>Input Level</u> (Lighter/Darker): Adjusts the black level of the input signal (e.g., L1, L2, L3) ● <u>Composite & S Video Output Level</u> (Lighter/Darker): When connected to a TV through the VIDEO OUT or S-VIDEO OUT terminal ● <u>Component Video Output Level</u> (Lighter/Normal/Darker): When connected to a TV through the COMPONENT VIDEO OUT (Y/P _B /P _R) terminals
Audio	PLAY ×1.3 & Audio during Search RAM DVD-R DVD-A DVD-V VCD Choose whether to have sound during the first level of fast-forward. ●You may hear sound regardless of this setting with some discs. DVD-A	● <u>On</u> ● <u>Off</u> : Quick View (⇒ page 20) does not work.
	D. Range Compression DVD-V (Dolby Digital only) Change the dynamic range for late night viewing.	● <u>On</u> ● <u>Off</u>
	Select MTS Select whether to record the main or secondary audio type (SAP) when recording to DVD-R or when recording using LPCM sound ("Audio Mode for XP Recording" ⇒ below).	● <u>Main</u> ● <u>SAP</u> –You cannot change secondary audio when recording audio to DVD-R from an external source.
	Audio Mode for XP Recording Choose the audio type when recording with XP mode. ●Sound recordings made using LPCM require more information than usual. Consequently the picture quality of LPCM recordings may be less than that of normal XP mode recordings.	● <u>Dolby Digital</u> (⇒ page 51) ● <u>LPCM</u> (⇒ page 51)
	Speaker Set the delay time for your center and surround speakers.	Multi Channel Center: 0.0/1.0/2.0/3.0/4.0/5.0 ms Surround (L/R): 0.0/ <u>5.0</u> /10.0/15.0 ms
Display	Status Messages Choose whether to show on-screen messages automatically.	● <u>Automatic</u> ● <u>Off</u>
	Language of Display Message Choose the language for these menus and the on-screen messages.	● <u>English</u> ● <u>Español</u> ● <u>Français</u>
	Blue Background	● <u>On</u> ● <u>Off</u> : When you do not want to have the unit show the blue background when reception is weak.
	FL Display Changes the brightness of the unit's display and the volume dial LED goes on or off.	● <u>Bright</u> ● <u>Dim</u> ● <u>Automatic</u> : The display turns dark during play, and reappears momentarily if a button is pressed. When the power is turned off all displays disappear. While using this mode the standby power consumption can be reduced.
TV Screen	TV Type (⇒ page 11) Choose the setting to suit your television.	● <u>Aspect 4:3 & 480I</u> ● <u>Aspect 4:3 & 480P</u> ● <u>Aspect 16:9 & 480I</u> ● <u>Aspect 16:9 & 480P</u>
	4:3 TV Settings for DVD-Video Select how DVD-Video widescreen picture is shown on a 4:3 standard aspect television.	● <u>Pan & Scan</u> (⇒ page 51): Video recorded for a widescreen is played as Pan & Scan (unless prohibited by the producer of the disc). ● <u>Letterbox</u> (⇒ page 51): Video recorded for a widescreen is played in the letterbox style.
	4:3 TV Settings for DVD-RAM Select how DVD-RAM widescreen picture is shown on a 4:3 standard aspect television.	● <u>4:3</u> : Programs played as recorded. ● <u>Pan & Scan</u> : Video recorded for a widescreen is played as Pan & Scan. ● <u>Letterbox</u> : Video recorded for a widescreen is played in the letterbox style.

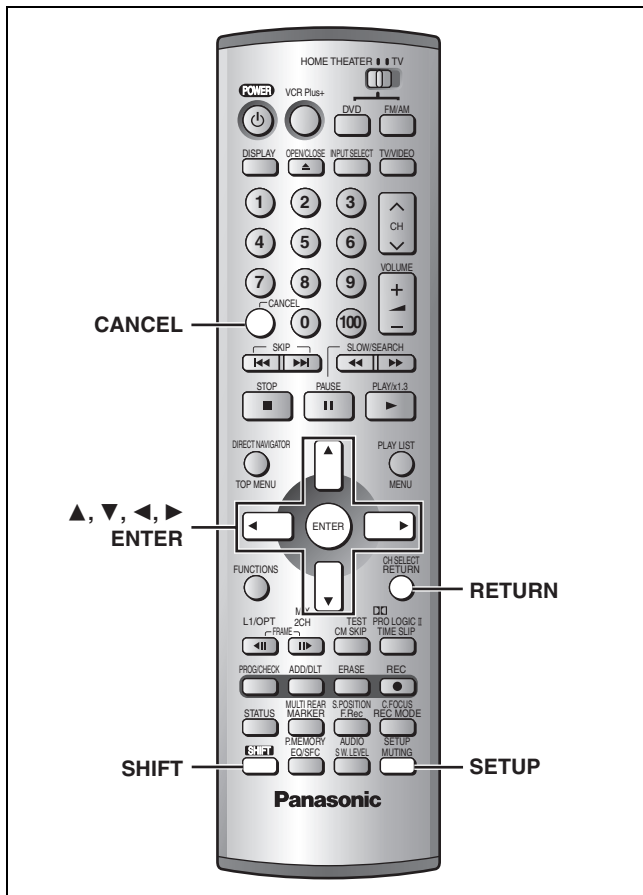

Antenna System and Auto Channel Setting

The unit sets the channels automatically. First, select to suit the type of antenna you are using. Channels are set corresponding to the antenna system you select.

While SETUP menu screen is displayed

- 1 Press [▲, ▼] to select “Channel” and press [▶].

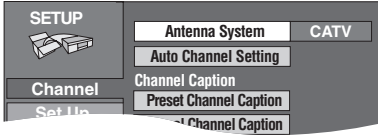

- 2 Press [▲, ▼] to select “Antenna System” and press [ENTER].

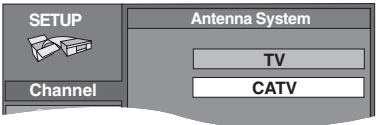

- 3 Press [▲, ▼] to select “TV” or “CATV” and press [ENTER].

The screen shown in step 1 reappears.

- 4 Press [▲, ▼] to select “Auto Channel Setting” and press [ENTER].

If you have not yet set clock, the “Auto Channel/Clock Setting” screen appears.

- 5 Press [ENTER] to start Auto Channel Setting.

This takes a few minutes. When finished, press [ENTER].

To cancel partway
Press [RETURN].

Common procedures

See pages 38 and 39 for menu and option details.

- 1 While stopped
Press [SHIFT]+[SETUP] to show the menus.

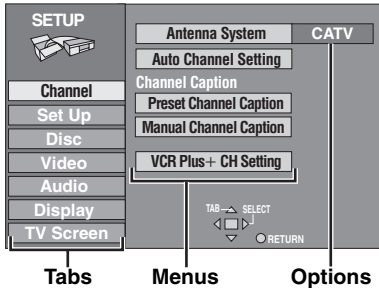

- 2 Press [▲, ▼] to select the menu's tab and press [▶].
- 3 Press [▲, ▼] to select the menu and press [ENTER].
- 4 Press [▲, ▼] to select the option and press [ENTER].

The screen now shows the menu again.

•Some items require different operations. Follow the on-screen instructions, or read the following explanations.

To return to the previous screen
Press [RETURN].

To exit the SETUP screen
Press [SHIFT]+[SETUP].

Other channel settings

You can give stations captions. You can use the preset captions, or manually enter new ones yourself. The captions you enter are displayed when the channel is displayed and in the Direct Navigator screen.

While **SETUP** menu screen is displayed

1 Press [**▲**, **▼**] to select “Channel” and press [**▶**].

Preset Channel Caption

You can give preset captions to the channels.

2 Press [**▲**, **▼**] to select “Preset Channel Caption” and press [**ENTER**].

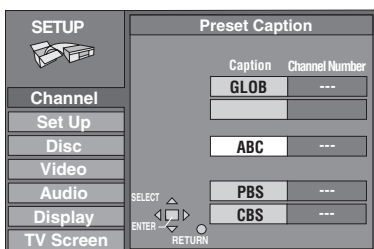

3 Press [**▲**, **▼**] to select the caption and then press [**▶**].

You can choose from the following captions.

ABC, PBS, CBS, CNN, FOX, ESPN, NBC, HBO, A&E, AMC, FAM, MAX, MTV, SHOW, TBS, USA, TNT, CBC, UPN, CTV, WB, TSN, DSC, GLOB

- The screen scrolls a page at a time if you press and hold [**▲**, **▼**].

4 Press [**▲**, **▼**] to select the channel corresponding to the caption and then press [**◀**].

- Channels are not displayed if they do not contain a station or if captions have been added manually.
- To delete the channel number, press [**CANCEL**].

Repeat steps 3 and 4 as necessary.

5 Press [**ENTER**].

Manual Channel Caption

You can set channel captions manually.

2 Press [**▲**, **▼**] to select “Manual Channel Caption” and press [**ENTER**].

3 Press [**▲**, **▼**] to select the channel and then press [**▶**].

- Channels are only displayed if they contain a station and if preset captions have not been added.

4 Press [**▲**, **▼**] to select the first character and then press [**▶**].

- You can choose from the following characters:
A–Z, 0–9, -, &, !, /, (space)
- To delete the caption, press [**CANCEL**].
- Repeat step 4 to enter the other characters.

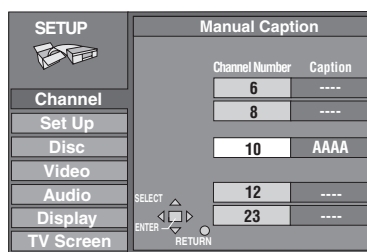

5 Press [**◀**, **▶**] to return to the Channel Number column when you are finished.

Repeat steps 3–5 as necessary.

6 Press [**ENTER**].

To return to the previous screen

Press [**RETURN**].

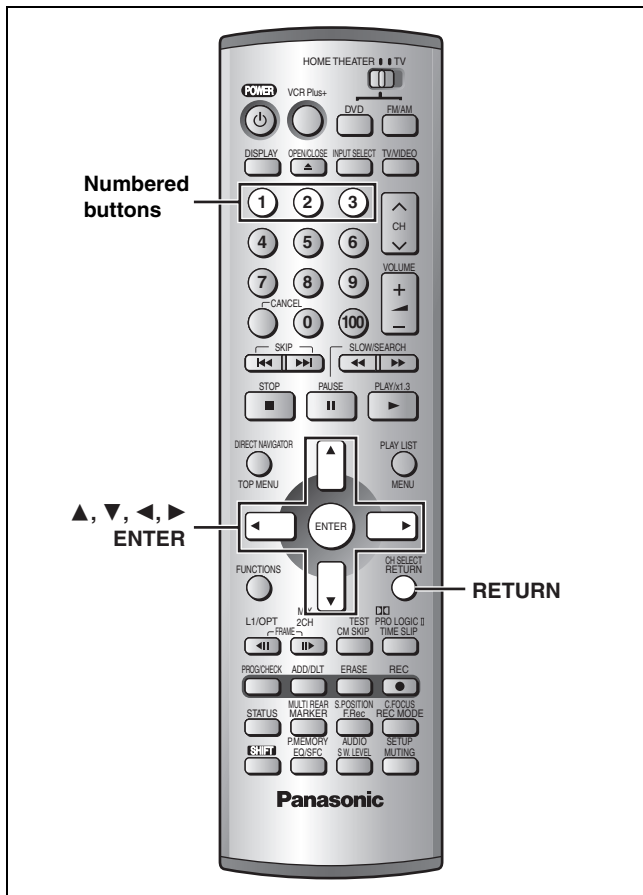

Changing the delay time (Speaker)

Enhance sound perception using this feature. Adjust the delay time for Dolby Digital when receiving multi-channel digital audio broadcast on satellite or cable TV, or for Dolby Pro Logic II when Dolby Pro Logic II is turned on.

While SETUP menu screen is displayed

- 1 Press [▲, ▼] to select "Audio" and press [▶].
- 2 Press [▲, ▼] to select "Speaker" and press [ENTER].

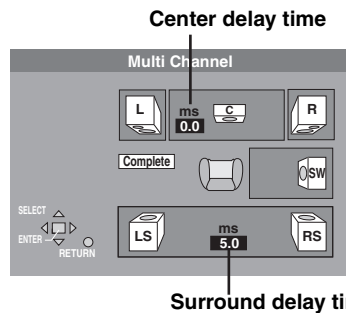

- 3 Press [▲, ▼] to select the delay time box and press [ENTER].
- 4 Press [▲, ▼] to adjust the delay time and press [ENTER].

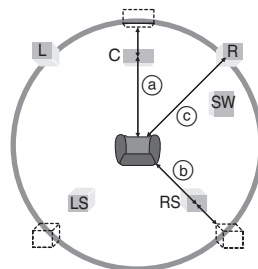

Values

If distance (a) or (b) is greater than or equal to distance (c), set to "0".
If distance (a) or (b) is less than distance (c), set as follows.

(a) Center speaker

Difference	Setting
Approx. 30 cm (1 foot)	1.0 ms
Approx. 60 cm (2 feet)	2.0 ms
Approx. 90 cm (3 feet)	3.0 ms
Approx. 120 cm (4 feet)	4.0 ms
Approx. 150 cm (5 feet)	5.0 ms

(b) Surround speakers

Difference	Setting
Approx. 150 cm (5 feet)	5.0 ms
Approx. 300 cm (10 feet)	10.0 ms
Approx. 450 cm (15 feet)	15.0 ms

When you change the surround speaker setting for Dolby Digital, the setting also changes for Dolby Pro Logic II.

When you are finished

Press [◀] to select "Complete" and press [ENTER].

Changing the remote control code

Panasonic DVD players and recorders use the same remote control system so they may respond unintentionally to a command from this remote control. Change the code on this unit and its remote control (the two must match) if you place equipment close together.

•Use "1", the factory set code, under normal circumstances.

While SETUP menu screen is displayed

- 1 Press [▲, ▼] to select "Set Up" and press [▶].
- 2 Press [▲, ▼] to select "Remote Control Code" and press [ENTER].
- 3 Press [▲, ▼] to select the code (1, 2, or 3) and press [ENTER].
The remote control code on the unit has been set.
- 4 While pressing [ENTER] on the remote control, press and hold for about 2 seconds the numbered button ([1], [2] or [3]) corresponding to the code you selected in step 3.

The remote control code on the remote control has been set.

The following display appears when you use a remote control with a different code.



The unit's remote control code

Change its code to match the unit's (→ step 4).

Clock settings

Preparation

If you connect the unit through a cable TV box or satellite receiver (⇒ page 44), tune to your local PBS station before starting auto clock setting. Use manual clock setting if auto clock setting does not work or if there is no local PBS channel in your area.

While **SETUP** menu screen is displayed

1 Press [**▲**, **▼**] to select “Set Up” and press [**▶**].

Auto Clock Setting

2 Press [**▲**, **▼**] to select “Auto Clock Setting” and press [**ENTER**].

If you have not yet set channels, the “Auto Channel/Clock Setting” screen appears.

3 Press [**ENTER**].

Auto setting starts. This can take some time, up to a few hours in some cases. (To stop auto clock setting, press [**RETURN**].) The following screen appears when setting is complete. Press [**ENTER**].

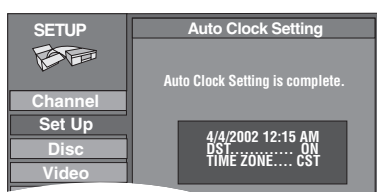

- If the time was not set correctly, use manual clock setting or time zone adjust.
 - DST, Daylight Saving Time, shows the summertime setting.
 - TIME ZONE shows the time difference from Greenwich meantime (GMT).
 - EST (Eastern Standard Time) = GMT -5
 - CST (Central Standard Time) = GMT -6
 - MST (Mountain Standard Time) = GMT -7
 - PST (Pacific Standard Time) = GMT -8
 - AST (Alaska Standard Time) = GMT -9
 - HST (Hawaii Standard Time) = GMT -10
- For other areas: xx hr

Time Zone Adjust

Adjust the time zone (-1 or +1) if it was not set correctly with auto clock setting.

You cannot change this setting if you set the clock manually.

2 Press [**▲**, **▼**] to select “Time Zone Adjust” and press [**ENTER**].

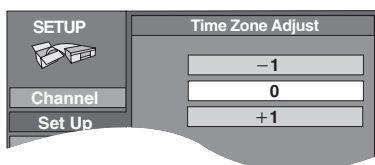

3 Press [**▲**, **▼**] to select “-1”, “0”, or “+1” and press [**ENTER**].

The “Set Up” screen (⇒ step 1) reappears.

Manual Clock Setting

2 Press [**▲**, **▼**] to select “Manual Clock Setting” and press [**ENTER**].

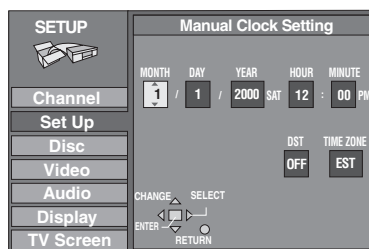

3 Press [**◀**, **▶**] to select the item you want to change and press [**▲**, **▼**] to change the setting.

MONTH ↔ DAY ↔ YEAR ↔ HOUR (12-hour display)

↑ ↔ TIME ZONE ↔ DST ↔ MINUTE ↔ ↓

DST (Daylight Saving Time): ON or OFF

If you select “ON”, the clock is advanced one hour starting at 2 a.m. on the first Sunday in April and ending at 2 a.m. on the last Sunday in October.

TIME ZONE (⇒ left):

EST ↔ CST ↔ MST ↔ PST ↔ AST ↔ HST
 (-5) (-6) (-7) (-8) (-9) (-10)

4 Press [**ENTER**].

The clock starts.

When you change the time zone, the recording times for programs recorded before the time zone was changed also change to correspond to the new time zone.

Optional connections

- The equipment connections described are examples.
- Peripheral equipment and optional cables sold separately unless otherwise indicated.
- Before connection, turn off all equipment and read the appropriate operating instructions.

Connecting other video equipment

■ Connecting to the L2 input terminals on the front of the unit

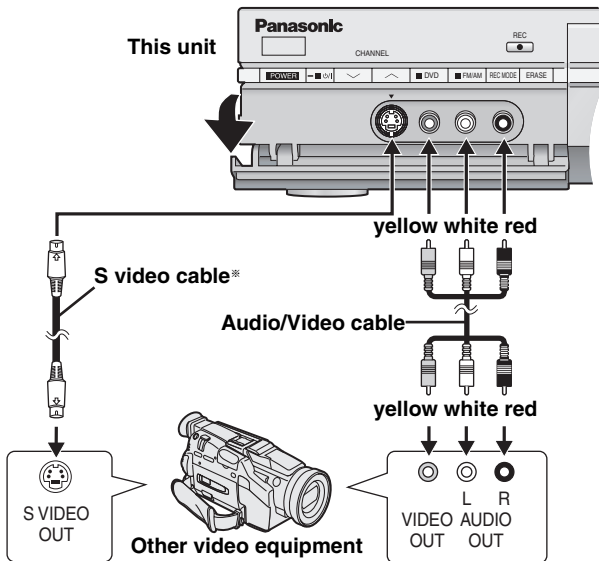

If the audio output of the other equipment is monaural, connect to L/MONO. (Both left and right channels are recorded when connected through L/MONO.)

■ Connecting to the input terminals on the rear of the unit, L1 or L3

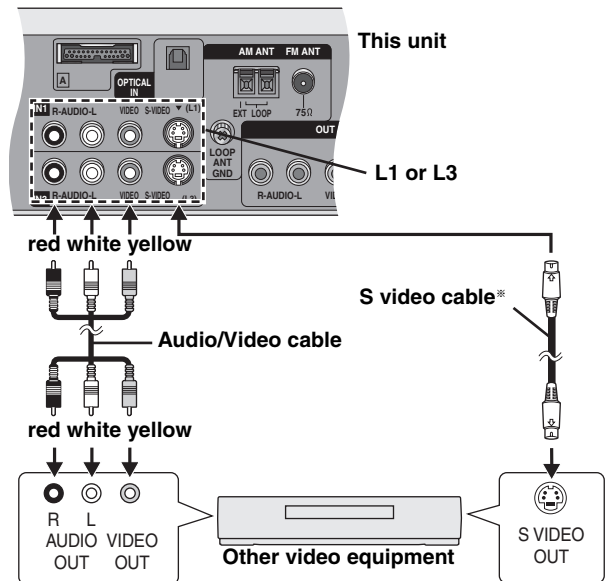

If audio output on the other equipment is monaural, use a stereo-monaural conversion cable (not included).

* By using the S video cable instead of the yellow video cable you may make recordings of higher picture quality.

Connecting a cable TV box/satellite receiver

You need to subscribe to a cable TV or satellite TV service, to enjoy viewing their programming.

- Consult your service provider regarding appropriate cable TV box or satellite receiver.
- Select the applicable input on your television to view the output from your cable TV box/satellite receiver through this unit.
- The signal from the cable TV box or satellite receiver passes through this unit to the television even when this unit is turned off.
- Change the video input on the television when you want to watch another program while recording.
- You cannot do a timer recording unless the channel is first selected on the cable TV box or satellite receiver.

A One cable TV box/satellite receiver

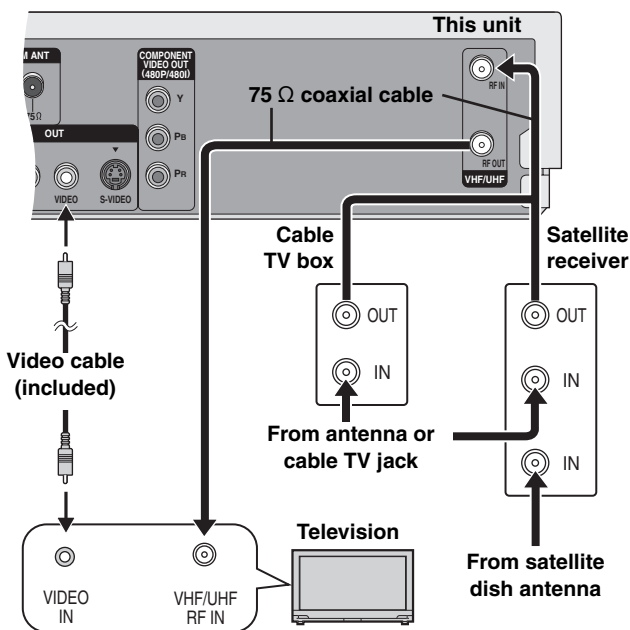

Note

When a home satellite system (Dishnetwork/DSS) is connected, auto tuning and auto clock setting may not operate properly. Set the clock manually (→ page 43).

B Two cable TV boxes

You can record and view both scrambled and unscrambled channels if connections are made as shown in the diagram below.

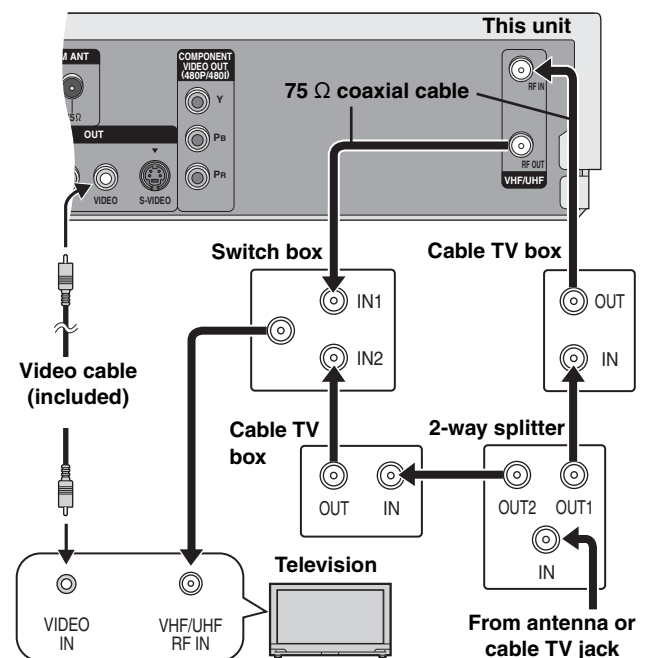

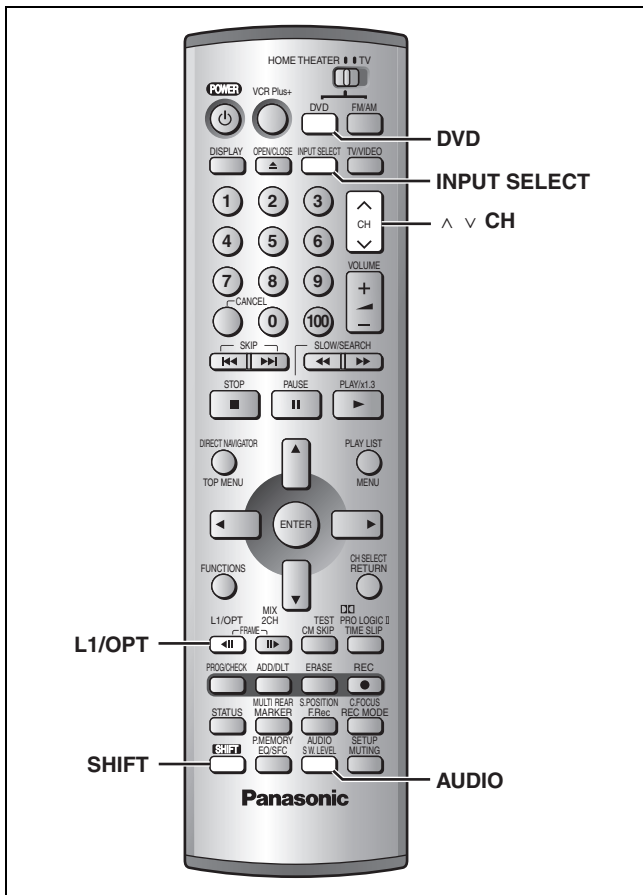

Receiving digital audio using the optical connection

If your cable TV box or satellite receiver has an OPTICAL OUT terminal you can connect with this unit's OPTICAL IN terminal to enjoy digital audio including multi-channel Dolby Digital. Refer to your cable TV box or satellite receiver's operating instructions for details.

Note

You cannot record digital audio received using the optical connection. Make certain to also connect to the L1 AUDIO/VIDEO terminals when using the OPTICAL IN terminal connection.

Make the following connections in combination with connections **A** or **B** on the previous page.

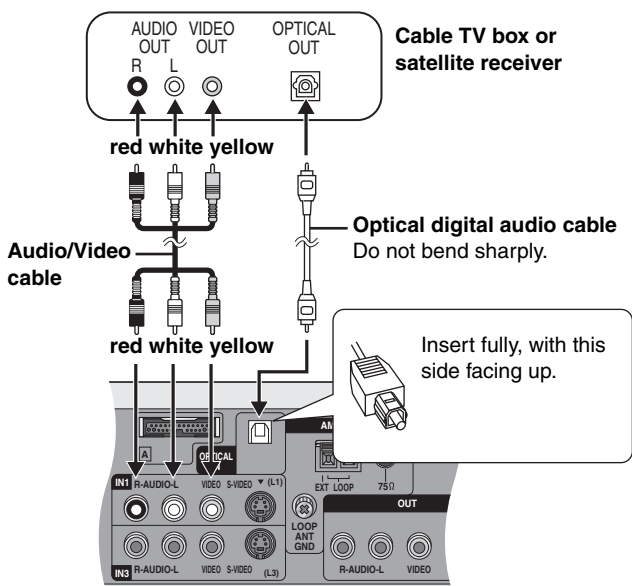

- 1 Press [INPUT SELECT] to select "L1".**
You can select the input channel by pressing [\wedge v CH].
- 2 Press [SHIFT]+[L1/OPT] to select audio input.**
L1 ANALOG (factory preset): Audio input into the L1 AUDIO terminals is output to the speakers.
L1 OPT: Audio input into the L1 OPTICAL IN terminal is output to the speakers.

When "L1 OPT" is selected

Audio reception setting
While "L1 OPT" is displayed on the unit's display Press and hold [SHIFT]+[L1/OPT].

L1 AUTO (factory preset): When receiving Dolby Digital and PCM signals
L1 PCM FIX: When receiving only PCM audio

When receiving Dolby Digital Dual Mono signals
You can change the audio mode.
Press [SHIFT]+[AUDIO].
MAIN \leftrightarrow SAP

Dynamic range compression
You can change this setting to listen to Dolby Digital sound at low volume (such as late at night) and maintain audio clarity. It reduces the peak level in loud scenes without affecting the sound field.
Press and hold for about 2 seconds [SHIFT]+[AUDIO].
DR COMP OFF (factory preset): The original dynamic range.
DR COMP STD: The level recommended for household viewing.
DR COMP MAX: The maximum allowable compression (recommended for night viewing).

Connecting other audio equipment

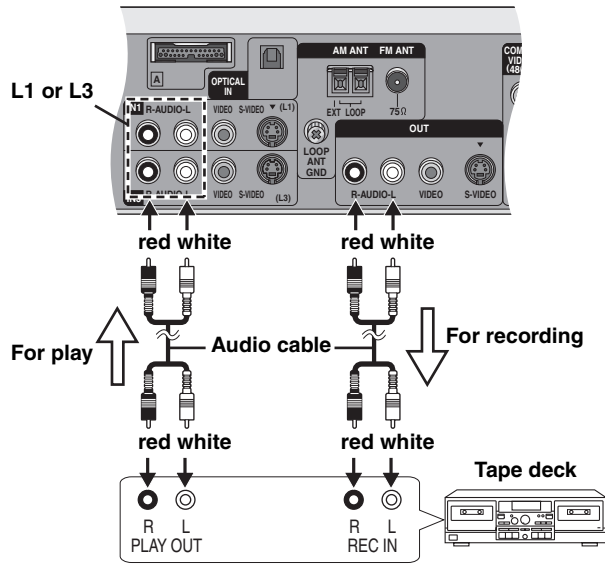

- Recording audio from discs or television broadcasts to a tape deck**
- 1 Discs: Press [DVD] to select "DVD/CD" as the source.
Television broadcasts: Press [\wedge v CH] to select the channel.
 - 2 Start recording and play.
- Refer to the manual of the other unit for details.

Note
FM/AM broadcasts and audio from the L1 OPTICAL IN terminal are not output through the AUDIO OUT terminals.

- To playback audio from a tape deck, etc., through this unit's speakers**
- 1 Press [DVD] to select "DVD/CD" as the source.
 - 2 Press [INPUT SELECT] to select "L1" or "L3".
 - 3 Start play.

Other antenna connections to the unit

Use one of the following connections to suit the antenna lead.

- If your television has both lead and coaxial VHF terminals, use the lead connection to minimize signal loss.

■ A single twin lead

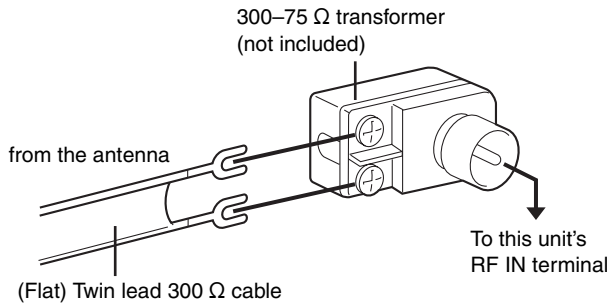

■ A twin lead and a coaxial cable

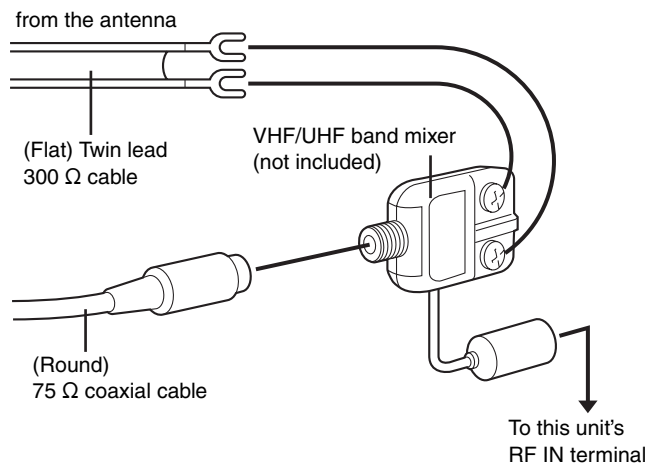

■ Two twin leads

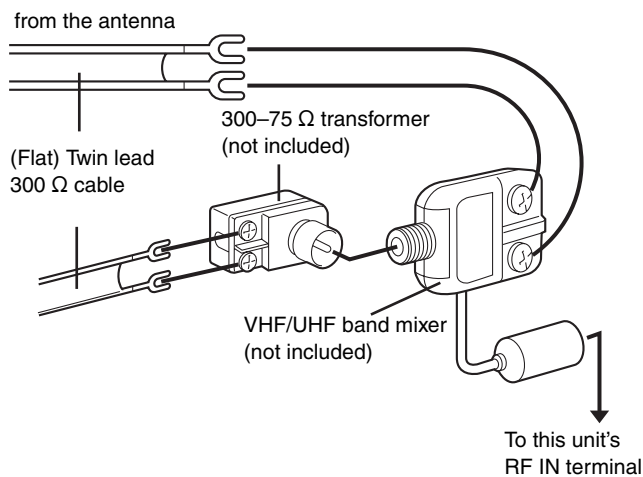

Other antenna connections from the unit to the television

Use one of the following connections to suit the antenna terminals on your television. Refer to the television's operating instructions.

- Connect to one of the terminals, then change the television's setting as necessary.

■ A twin lead and coaxial plug terminal

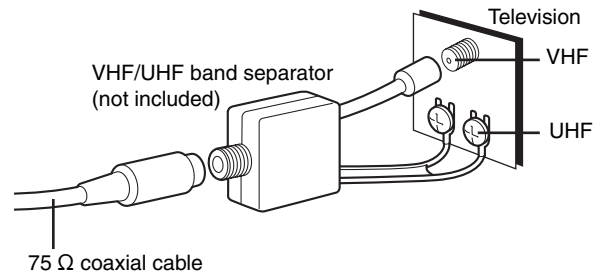

■ A twin lead terminal

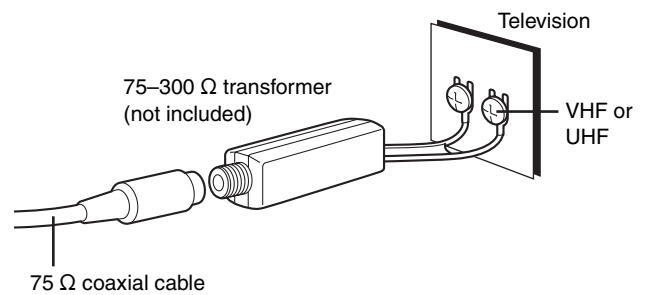

■ Two twin lead terminals

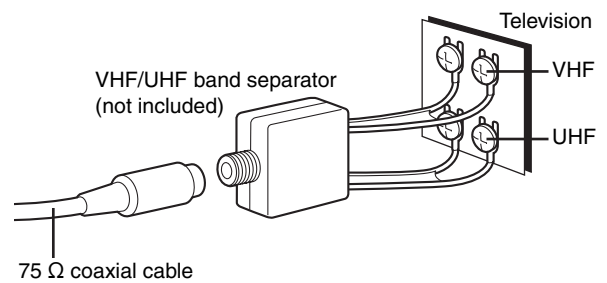

■ Multiple antenna terminals

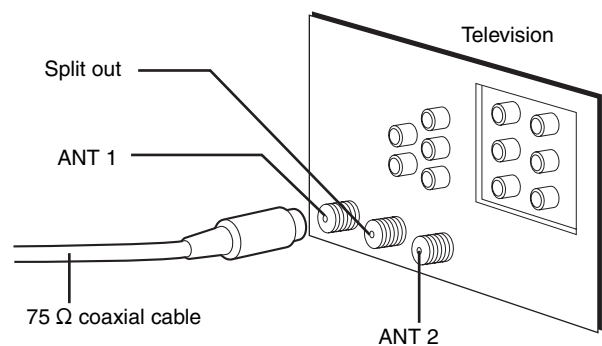

On the television

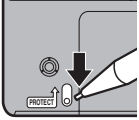
		Page
Cannot finish recording completely.	<ul style="list-style-type: none"> The program was copy-guarded. No space left on the disc. <ul style="list-style-type: none"> Create space by erasing any unwanted programs. RAM Use a new disc. RAM DVD-R Recording was not completed for some other reason. 	— 30 — —
Cannot record on the disc.	<ul style="list-style-type: none"> The disc is scratched. Use another disc. The disc is dirty. You inserted an incompatible disc. 	— 53 8
Contents of this disc are protected.	<ul style="list-style-type: none"> The program is write-protected. Cancel the protection. The disc is write-protected. Cancel Disc Protection. 	30 32
Disc is full.	<ul style="list-style-type: none"> No space left on the disc. <ul style="list-style-type: none"> Create space by erasing any unwanted programs. RAM Use a new disc. RAM DVD-R 	30 —
Error has occurred. Please press ENTER.	<ul style="list-style-type: none"> A serious, but temporary error has occurred and one of the unit's safety devices has activated. Press [ENTER]. The unit switches to the standby mode. Press [POWER] to turn the unit on again. 	—
Finalizing is necessary for compatible playback.	<ul style="list-style-type: none"> To enable playback of your DVD-R on compatible equipment, it is necessary to finalize it. 	33
No disc.	<ul style="list-style-type: none"> You haven't inserted a disc. Correctly insert a disc that this unit can use. The disc is upside down. If it is a single-sided disc, insert it so the label is facing up. 	8 12
Please check write protect tab on the disc.	<ul style="list-style-type: none"> The write-protect tab on the cartridge is set to PROTECT. Use a ballpoint pen or similar to release the write protection. 	—
Please set clock.	<ul style="list-style-type: none"> The clock is not set. 	43
This disc cannot be read.	<ul style="list-style-type: none"> You inserted an incompatible disc. 	8
This disc may not be played in your region.	<ul style="list-style-type: none"> You tried to play a disc with a region number different from this unit's region number. This unit can only play discs with the region numbers compatible with this unit (1, All, or including the number 1). 	Cover page
This is non-recordable disc.	<ul style="list-style-type: none"> The unit cannot record on the disc you inserted. Insert a DVD-RAM or unfinalized DVD-R. 	8
This disc is not formatted properly. Please format the disc in 'DISC SETTING' to record.	<ul style="list-style-type: none"> You inserted an unformatted DVD-RAM. Format the disc with this unit. 	33
Your selection exceeds the recorder's rating limit.	<ul style="list-style-type: none"> A ratings level has been set for DVD-Video with this unit. Unlock the unit with "Ratings" in "Disc". 	38

On the unit's display

<input type="checkbox"/> CHK REMOTE (“□” stands for a number.)	<ul style="list-style-type: none"> The remote control and main unit are using different codes. Change the code on the remote control. 	42
AF F61	<ul style="list-style-type: none"> Check and correct the speaker cord connections. If this does not fix the problem, there is a power supply problem. Consult the dealer. 	Setup Guide
DIGITAL UNLOCK	<ul style="list-style-type: none"> There is no signal input to the L1 OPTICAL IN terminal. <ul style="list-style-type: none"> Make sure to check the connections and if the power of the connected equipment is turned on. 	—
NO READ	<ul style="list-style-type: none"> The disc is dirty or badly scratched. <ul style="list-style-type: none"> Clean the disc if it is dirty. The disc cannot be played if it is scratched and this display doesn't disappear. The unit cannot read the disc. You have used a DVD-RAM/PD lens cleaner and it has finished. 	53 — — 53
SELF CHECK	<ul style="list-style-type: none"> There was a power failure or the AC plug was disconnected while the power was on. The unit is carrying out its recovery process. Wait until the message disappears. 	—
U14	<ul style="list-style-type: none"> The unit is hot. <ul style="list-style-type: none"> The unit switches to standby automatically for safety reasons and you cannot operate it. Wait for about 30 minutes for the service number to disappear. Select a position with good ventilation when installing the unit. Do not block the cooling fan on the rear of the unit. 	— — —
U99	<ul style="list-style-type: none"> The unit fails to operate properly. Press [POWER] to switch the unit to standby. Now press [POWER] again to turn the unit on. 	—
UNSUPPORT	<ul style="list-style-type: none"> You have inserted a disc the unit cannot play or record on. The signal input into the L1 OPTICAL IN terminal is not Dolby Digital or Linear PCM. 	8 —

Troubleshooting guide

Before requesting service, make the below checks. If you are in doubt about some of the check points, or if the remedies indicated in the chart do not solve the problem:

In the U.S.A., contact the Panasonic Customer Call Center at 1-800-211-7262, or e-mail consumerproducts@panasonic.com, or the website (<http://www.panasonic.com>).

In Canada, contact the Panasonic Canada Inc. Customer Care Centre at 1-800-561-5505, or visit the website (www.panasonic.ca), or an authorized Servicentre closest to you.

Power		Page
No power.	<ul style="list-style-type: none"> Insert the AC power supply cord and system cable securely. 	Setup Guide
The unit switches to the standby mode.	<ul style="list-style-type: none"> This is a power saving feature. You can turn it off if you would prefer (Set Up—Off Timer—Off). Press [⏻ POWER] to turn the unit on. One of the unit's safety devices may have activated. Press [⏻ POWER] to turn the unit on. 	38 —

Operation

The unit is on but cannot be operated.	<ul style="list-style-type: none"> Some operations may be prohibited by the disc. The unit is hot ("U14" appears on the display). Wait for "U14" to disappear. One of the unit's safety devices may have activated. Reset the unit as follows: <ol style="list-style-type: none"> Press [⏻ POWER] to switch the unit to standby. If the unit doesn't switch to standby, press and hold [⏻ POWER] for about 10 seconds. The unit is forcibly switched to standby. Alternatively, disconnect the AC power supply cord, wait one minute, then reconnect it. Press [⏻ POWER] to turn the unit on. 	— 47 —
During disc operation the unit does not respond.	<ul style="list-style-type: none"> The selector has been set to "FM" or "AM". Press [DVD] to select "DVD/CD" as the source. 	—

Remote control

The remote control doesn't work.	<ul style="list-style-type: none"> [HOME THEATER, TV] is not switched to "HOME THEATER". Switch to "HOME THEATER" when operating this unit. The remote control and main unit are using different codes. Change the code on the remote control. The batteries are depleted. Replace them with new ones. Point the remote control at the remote control sensor on the main unit. Remove obstacles from between the remote control and main unit. 	— 42 2 — —
Cannot operate the television.	<ul style="list-style-type: none"> Change manufacturer code. Some televisions cannot be operated even if you change the code. [HOME THEATER, TV] is not switched to "TV". Switch to "TV" when selecting the receiving channel for the television. 	11 11

Picture

•When progressive output is on, refer also to "Progressive video" below.

The images from this unit do not appear on the television.	<ul style="list-style-type: none"> Make sure that the television is connected to the VIDEO OUT terminal, S-VIDEO OUT terminal or COMPONENT VIDEO OUT terminals on this unit. Make sure that the television's input setting (e.g., VIDEO 1) is correct. You have set "TV Type" to "Aspect 4:3 & 480P" or "Aspect 16:9 & 480P" in the TV Screen menu, but the television isn't compatible with progressive signals. Press and hold [■] and [TIME SLIP] on the unit at the same time for about 5 seconds. The setting will change to interlace. 	Setup Guide — —
Television reception worsens after connecting the unit.	<ul style="list-style-type: none"> This can occur because the signals are being divided between the unit and the television. It can be solved by using a signal booster, available from audio-visual suppliers. Consult your dealer if reception does not improve. 	—
Screen size is wrong.	<ul style="list-style-type: none"> Check the settings on your television. Check the settings for "TV Type", "4:3 TV Settings for DVD-Video" or "4:3 TV Settings for DVD-RAM" in the TV Screen menu. 	— 11, 39
On-screen messages do not appear.	<ul style="list-style-type: none"> Go to the Display menu and select "Automatic" for "Status Messages". Press [STATUS] to show the on-screen messages constantly. 	39 24
The blue background does not appear.	<ul style="list-style-type: none"> Go to the Display menu and select "On" for "Blue Background". 	39
There is ghosting.	<ul style="list-style-type: none"> Change the settings for "3D NR", "Block NR", and "Mosquito NR" to "0" or turn "MPEG-DNR" off if it is on. 	23
Play stops for a moment during Quick View.	<ul style="list-style-type: none"> Play may stop where two play lists join, but this is not a malfunction. 	—

Progressive video

There is ghosting when progressive output is on.	<ul style="list-style-type: none"> Set "Progressive" to "OFF". This problem is caused by the editing method or material used on DVD-Video, but should be corrected if you use interlace output. 	23
There is no apparent change in picture quality when adjusted with the Video menu in the on-screen menus.	<ul style="list-style-type: none"> The effect is less perceivable with some types of video. 	—

Recording and timer recording

		Page
Cannot record.	•You haven't inserted a disc or the disc you inserted cannot be recorded on. Insert a disc the unit can record onto.	8
	•The disc is unformatted. Format the disc so this unit can record on it. RAM	33
	•The write-protect tab on the cartridge is set to PROTECT.	8
	•Some programs have limitations on the number of times they can be recorded (CPRM).	51
	•The disc is protected with DISC SETTING.	32
	•The disc is full or nearly full. Erase unneeded programs or use another disc.	30
	•You cannot record on finalized DVD-R discs.	—
	•Audio from FM/AM broadcasts and the L1 OPTICAL IN terminal cannot be recorded.	—
VCR Plus+ programming does not work properly.	•The guide channels are incorrect. Go to the Channel menu and correct them with "VCR Plus+ CH Setting".	10
	•The clock is wrong. Go to the Set Up menu and correct it with Clock settings.	43
Timer recording does not work properly.	•The timer program is incorrect. Correct the program.	16
	•The unit is not on timer recording standby. ("⊕" on the unit's display is not on.) Press [⏻ POWER] to turn the unit off and make sure that "⊕" is on.	—
	•Different timer program times overlap.	—
	•The clock is wrong. Go to the Set Up menu and correct it with Clock settings.	43
The unit switches to standby while making a timer recording.	•The disc has run out of space. Use a disc that has enough space to record the program.	—
The timer program remains even after recording finishes.	•The timer program remains if set to daily or weekly.	15
Timer recording does not stop even when [■] is pressed.	•Press [■] and then [ENTER] within 5 seconds to turn "⊕" off. Recording stops.	—
The available recording time doesn't increase even after erasing recordings on the disc.	•As this unit is unable to erase data written to DVD-RAM with a computer, the available recording time does not increase. The data will be erased if you reformat the disc.	33
	•If the disc is dirty, wipe with the DVD-RAM/PD disc cleaner (optional) before formatting.	53
	•Available recording space on the DVD-R does not increase even after erasing previously recorded programming.	—
A part or whole of a recorded program has been lost.	<ul style="list-style-type: none"> •If there is a power failure or the plug is disconnected from the household AC outlet while recording or editing, the program may be lost or the disc may become unusable. <ul style="list-style-type: none"> ➤ We cannot offer any guarantee regarding lost programs or discs. You will have to format the disc or use a new disc. 	—

Play

Play fails to start even when [▶] (PLAY) is pressed. Play starts but then stops immediately.	•Insert the disc correctly with the label facing up.	12
	•This unit cannot play discs other than the ones listed in these operating instructions.	8
	•The disc is dirty. Clean it.	53
	•The disc may be badly scratched.	—
	•You inserted a blank DVD-RAM or DVD-R.	—
	•Condensation has formed: Wait 1 to 2 hours for it to evaporate.	—
A title or chapter doesn't play when it is selected.	•Some titles and chapters on DVD-Video are not played when you have changed the ratings level.	38
Picture distorted during search.	•Some distortion is normal.	—
Alternative soundtrack and subtitles cannot be selected.	•The languages are not recorded on the disc.	—
	•You may have to use the disc's menus to select languages.	19
No subtitles.	•Subtitles are not recorded on the disc.	—
	•Turn the subtitles on.	22
	•Subtitles around markers may fail to appear.	—
Angle cannot be changed.	•This function depends on software availability. Angles can only be changed during scenes where different angles are recorded.	—
You have forgotten your ratings password.	<ul style="list-style-type: none"> •Return the ratings setting to "8". While the disc tray is open, press and hold [◀◀/▶▶] and [▶▶/▶▶▶] on the main unit at the same time for 5 or more seconds. 	—

Displays

The display is dim.	•Go to the Display menu and change the display's brightness with "FL Display".	39
"12:00" is flashing on the unit's display.	•The clock is not set.	43
The displayed recording time and actual recording time differ.	•Displayed recording time is based on the number of frames per second. This number is subject to minute variations. When recording over long periods, these variations may result in the difference between displayed recording time and actual recording time. This is normal.	—
The display doesn't show the correct time. MP3	•Times may not appear correctly when searching through tracks recorded with a variable bit rate.	—

Radio and sound		Page
Cannot select the tuner	<ul style="list-style-type: none"> Check and see if the subwoofer's AC power supply cord is connected. 	Setup Guide
Noise is heard. "ST" is flashing or doesn't light. Sound is distorted.	<ul style="list-style-type: none"> Adjust the position of the FM or AM antenna. Use an FM outdoor antenna. 	— 35
A beat sound is heard.	<ul style="list-style-type: none"> Turn the television off or separate it from the unit. 	—
A low hum is heard during AM broadcasts.	<ul style="list-style-type: none"> Separate the antenna from other cables and cords. 	—
The radio cannot be tuned in.	<ul style="list-style-type: none"> Turn off nearby televisions, video cassette recorders, satellite receivers and computers. 	—
All programmed radio presets are erased. Returns to the original setting even after making changes to the sound field system settings.	<ul style="list-style-type: none"> Radio and sound field system settings are stored to memory after pressing [⏻ POWER]. Do not remove the AC power supply cords until "BYE" disappears from the unit's display. 	—
No sound. Low volume. Distorted sound.	<ul style="list-style-type: none"> Check the connections. Turn the volume up. Turn muting off. Switch off the unit, determine and correct the cause, then switch the unit on. Causes include: <ul style="list-style-type: none"> Shorting (bare wires touching) of positive and negative speaker wires. Using speakers with an impedance lower than that rated for this unit. Straining of the speakers through excessive volume or power. Using the unit in a hot environment without proper ventilation. 	Setup Guide — 6 —
Humming heard during play.	<ul style="list-style-type: none"> An AC power supply cord or fluorescent light is near the subwoofer. Keep other appliances and cords away from the subwoofer. 	—
Cannot hear the desired audio type.	<ul style="list-style-type: none"> Press [SHIFT]+[AUDIO] to select the desired audio type. You cannot change the DVD-Audio audio type if the software producer has restricted play in stereo. 	19 —
Cannot switch audio during stereo or SAP broadcasts.	<ul style="list-style-type: none"> You cannot change the audio type when a DVD-R is in the disc tray. It is not possible to switch the audio when the recording mode is XP and "LPCM" has been selected in the SETUP menu, "Audio Mode for XP Recording". <ul style="list-style-type: none"> Select "Main" or "SAP" from "Select MTS" in the Audio menu before recording. 	— 39
Beginning of audio is cut off when receiving audio from a digital broadcast using the optical connection.	<ul style="list-style-type: none"> When using the "L1 AUTO" setting, sound may be cut off when the signal is being switched automatically between Dolby Digital and PCM. Set to "L1 PCM FIX" to avoid this. 	45

Discs make sounds as they rotate. This does not indicate a malfunction.

Language code list Input the code with numbered buttons.

Abkhazian: 6566	Catalan: 6765	Gujarati: 7185	Lingala: 7678	Rhaeto-Romance: 8277	Tamil: 8465
Afar: 6565	Chinese: 9072	Hausa: 7265	Lithuanian: 7684	Romanian: 8279	Tatar: 8484
Afrikaans: 6570	Corsican: 6779	Hebrew: 7387	Macedonian: 7775	Russian: 8285	Telugu: 8469
Albanian: 8381	Croatian: 7282	Hindi: 7273	Malagasy: 7771	Samoan: 8377	Thai: 8472
Ameharic: 6577	Czech: 6783	Hungarian: 7285	Malay: 7783	Sanskrit: 8365	Tibetan: 6679
Arabic: 6582	Danish: 6865	Icelandic: 7383	Malayalam: 7776	Scots Gaelic: 7168	Tigrinya: 8473
Armenian: 7289	Dutch: 7876	Indonesian: 7378	Maltese: 7784	Serbian: 8382	Tonga: 8479
Assamese: 6583	English: 6978	Interlingua: 7365	Maori: 7773	Serbo-Croatian: 8372	Turkish: 8482
Aymara: 6588	Esperanto: 6979	Irish: 7165	Marathi: 7782	Shona: 8378	Turkmen: 8475
Azerbaijani: 6590	Estonian: 6984	Italian: 7384	Moldavian: 7779	Sindhi: 8368	Tw: 8487
Bashkir: 6665	Faroese: 7079	Japanese: 7465	Mongolian: 7778	Singhalese: 8373	Ukrainian: 8575
Basque: 6985	Fiji: 7074	Javanese: 7487	Nauru: 7865	Slovak: 8375	Urdu: 8582
Bengali, Bangla: 6678	Finnish: 7073	Kannada: 7578	Nepali: 7869	Slovenian: 8376	Uzbek: 8590
Bhutani: 6890	French: 7082	Kashmiri: 7583	Norwegian: 7879	Somali: 8379	Vietnamese: 8673
Bihari: 6672	Frisian: 7089	Kazakh: 7575	Oriya: 7982	Spanish: 6983	Volapük: 8679
Breton: 6682	Galician: 7176	Kirghiz: 7589	Pashto, Pushto: 8083	Sundanese: 8385	Welsh: 6789
Bulgarian: 6671	Georgian: 7565	Korean: 7579	Persian: 7065	Swahili: 8387	Wolof: 8779
Burmese: 7789	German: 6869	Kurdish: 7585	Polish: 8076	Swedish: 8386	Xhosa: 8872
Byelorussian: 6669	Greek: 6976	Laotian: 7679	Portuguese: 8084	Tagalog: 8476	Yiddish: 7473
Cambodian: 7577	Greenlandic: 7576	Latin: 7665	Punjabi: 8065	Tajik: 8471	Yoruba: 8979
	Guarani: 7178	Latvian, Lettish: 7686	Quechua: 8185		Zulu: 9085

CPRM (Content Protection for Recordable Media)

CPRM is the copyright protection technology that is used to protect broadcasts that are allowed to be recorded only once (e.g. some CATV broadcasts).

Decoder

A decoder restores the coded audio signals on DVDs to normal.

Dolby Digital

This is a method of coding digital signals developed by Dolby Laboratories. Apart from stereo (2-channel) audio, these signals can also be multi-channel audio. A large amount of audio information can be recorded on one disc using this method.

This unit is set to record using Dolby Digital in all recording modes.

Dolby Pro Logic II

Dolby Pro Logic II is an advanced decoder that derives 5 channel surround (Left, Center, Right, Left and Right Surround) from any stereo program material, whether or not it has been specifically Dolby Surround encoded. Pro Logic II provides two full-range surround channels, as opposed to Pro Logic's single surround channel.

DTS (Digital Theater Systems)

This surround system is used in many movie theaters around the world. There is good separation between the channels, so realistic sound effects are possible.

Film and video

DVD-Videos are recorded using either film or video. Usually, film is recorded at 24 frames per second, the rate movies are filmed at, while video is recorded at 30 frames per second.

Frame still and field still

Frames are the still pictures that make moving pictures. About thirty are shown each second. A frame still may appear blurred but overall quality is high.

Two fields appear alternately to make up one frame. A field still is not blurred but picture quality is lower.

Interlace and progressive output

NTSC, the video signal standard, has 480 interlaced (I) scan lines, whereas progressive scanning uses twice the number of scan lines. This is called 480P.

I/P/B

MPEG 2, the video compression standard adopted for use with DVD-Video, codes frames using these 3 picture types.

I: Intra coded picture

This picture has the best quality and is the best to use when adjusting the picture.

P: Predictive coded picture

This picture is calculated based on past I- or P-pictures.

B: Bidirectionally-predictive coded picture

This picture is calculated by comparing past and future I- and P-pictures so it has the lowest volume of information.

Linear PCM (pulse code modulation)

These are uncompressed digital signals, similar to those found on CDs. LPCM sound is available when recording in XP mode.

Playback control (PBC)

If a Video CD has playback control, you can select scenes and information with menus.

Pan&Scan/Letterbox

In general, DVD-Video are produced with the intention that they be viewed on a widescreen television with an aspect ratio of 16:9. This means you can view most material with the intended aspect ratio on a widescreen television.

Material with this ratio will not fit onto a standard television with an aspect ratio of 4:3. Two styles of picture, "Pan&Scan" and "Letterbox", deal with this problem.

Pan&Scan: The sides are cut off so the picture fills the screen.



Letterbox: Black bands appear at the top and bottom of the picture so the picture itself appears in an aspect ratio of 16:9.



Listening caution



Selecting fine audio equipment such as the unit you've just purchased is only the start of your musical enjoyment. Now it's time to consider how you can maximize the fun and excitement your equipment offers. This manufacturer and the Electronic Industries Association's Consumer Electronics Group want you to get the most out of your equipment by playing it at a safe level. One that lets the sound come through loud and clear without annoying blaring or distortion—and, most importantly, without affecting your sensitive hearing.

We recommend that you avoid prolonged exposure to excessive noise.

Sound can be deceiving. Over time your hearing "comfort level" adapts to higher volumes of sound. So what sounds "normal" can actually be loud and harmful to your hearing.

Guard against this by setting your equipment at a safe level BEFORE your hearing adapts.

To establish a safe level:

- Start your volume control at a low setting.
- Slowly increase the sound until you can hear it comfortably and clearly, and without distortion.

Once you have established a comfortable sound level:

- Set the dial and leave it there.

Taking a minute to do this now will help to prevent hearing damage or loss in the future. After all, we want you listening for a lifetime.



■ AMPLIFIER SECTION

RMS total power output	700 W
1 kHz, 10 % total harmonic distortion	
Front:	60 W per channel (6 Ω)
Center:	220 W (6 Ω)
Surround:	60 W per channel (6 Ω)
100 Hz, 10 % total harmonic distortion	
Subwoofer:	240 W (4 Ω)
FTC total power output	430 W
120 Hz–20 kHz, 1.0 % total harmonic distortion	
Front:	35 W per channel (6 Ω)
Center:	140 W (6 Ω)
Surround:	35 W per channel (6 Ω)
45 Hz–120 Hz, 1.0 % total harmonic distortion	
Subwoofer:	150 W (4 Ω)
Input sensitivity/Input impedance	
L1/L2/L3:	350 mV, 47 kΩ
Digital input	Optical input (Dolby Digital, Linear PCM)

■ TV TUNER SECTION

Antenna reception input:	TV Channel: 2 ch–69 ch, 75 Ω
	CATV Channel: 1 ch–125 ch, 75 Ω

■ FM TUNER SECTION

Frequency range:	87.9–107.9 MHz (200-kHz step)
	87.5–108.0 MHz (100-kHz step)
Antenna terminals:	75 Ω unbalanced

■ AM TUNER SECTION

Frequency range:	520–1710 kHz (10-kHz step)
-------------------------	----------------------------

■ DISC SECTION

Recording system:	DVD video recording standards (DVD-RAM)
	DVD video standards (DVD-R)

LASER Specification

Class I LASER Product	
Pick up:	System with 1 lens, 2 integration units
	Wavelength: 790 nm for CD/VCD, 662 nm for DVD
Recordable discs:	12 cm (5") 4.7 GB/9.4 GB DVD-RAM discs
	8 cm (3") 2.8 GB DVD-RAM discs
	12 cm (5") 4.7 GB DVD-R discs (for General Ver. 2.0)
	8 cm (3") 1.4 GB DVD-R discs (for General Ver. 2.0)
Recording time:	XP: 60 minutes
	SP: 120 minutes
	LP: 240 minutes
	EP: 360 minutes
Playable discs:	12 cm (5") 4.7 GB/9.4 GB DVD-RAM discs
	8 cm (3") 2.8 GB DVD-RAM discs
	12 cm (5") 4.7 GB DVD-R discs (for General Ver. 2.0)
	8 cm (3") 1.4 GB DVD-R discs (for General Ver. 2.0)
	DVD-AUDIO/VIDEO discs
	CD-Audio discs (CD-DA)
	Video CD discs
	CD-R/CD-RW discs
	[CD-DA, Video CD (Ver. 2.0), MP3 formatted discs]

Video system

TV system:	NTSC system, 525 lines, 60 fields
Recording system:	MPEG2 (Hybrid VBR)
Output terminal:	RCA (composite video)
	S terminal (Y, C)
	RCA (component video 480P/480i)

Audio system

Recording system:	Dolby Digital (XP/SP/LP/EP)
	Linear PCM (XP only)
Number of channels:	Recording: 2 channels
	Playback: 5.1 channels
	(FL, FR, Center, SL, SR, Subwoofer)

■ SPEAKER SECTION

● Front speakers **[SB-PF1000]**

Type:	2 way, 2 speaker system, Bass-ref.
Woofers:	6.5 cm (2 ¹ / ₂ ") CONE type
Tweeter:	6 cm (2 ³ / ₈ ") RING SHAPED DOME type
Impedance/Input power (IEC):	6 Ω/60 W (Max)
Output sound pressure level:	82 dB/W (1.0 m)
Frequency range:	90 Hz–50 kHz (–16 dB)
	100 Hz–45 kHz (–10 dB)
Dimensions (W×H×D):	240×1138 (Max)/678 (Min)×240 mm
	[9 ⁷ / ₁₆ "×44 ¹³ / ₁₆ " (Max)/26 ¹¹ / ₁₆ " (Min)×9 ⁷ / ₁₆ "]
	Speaker height adjustment range: 1138–968 mm (44 ¹³ / ₁₆ "–38 ¹ / ₈ "),
	796–625 mm (31 ¹¹ / ₃₂ "–24 ¹⁹ / ₃₂ ")
	[However, the height of the stand is fixed at 678 mm (26 ¹¹ / ₁₆ ").]
Mass:	Approx. 3.7 kg (8.2 lb.)

● Center speaker **[SB-PC1000]**

Type:	2 way, 3 speaker system, Bass-ref.
Woofers:	6.5 cm (2 ¹ / ₂ ") CONE type×2
Tweeter:	6 cm (2 ³ / ₈ ") RING SHAPED DOME type
Impedance/Input power (IEC):	6 Ω/220 W (Max)※
Output sound pressure level:	84 dB/W (1.0 m)
Frequency range:	100 Hz–50 kHz (–16 dB)
	120 Hz–45 kHz (–10 dB)
Dimensions (W×H×D):	320×97×93 mm (12 ¹⁹ / ₃₂ "×3 ¹³ / ₁₆ "×3 ²¹ / ₃₂ ")
Mass:	Approx. 1.5 kg (3.3 lb.)
	※ Ratings with the low cut filter equipped amplifier.

● Surround speakers **[SB-PS1000]**

Type:	2 way, 2 speaker system, Bass-ref.
Woofers:	6.5 cm (2 ¹ / ₂ ") CONE type
Tweeter:	6 cm (2 ³ / ₈ ") RING SHAPED DOME type
Impedance/Input power (IEC):	6 Ω/60 W (Max)
Output sound pressure level:	80 dB/W (1.0 m)
Frequency range:	95 Hz–50 kHz (–16 dB)
	110 Hz–45 kHz (–10 dB)
Dimensions (W×H×D):	160×224×107 mm (6 ⁵ / ₁₆ "×8 ¹³ / ₁₆ "×4 ⁷ / ₃₂ ")
Mass:	Approx. 1.5 kg (3.3 lb.)

● Subwoofer **[SB-WA351]**

Type:	1 way, 1 speaker system, Bass-ref.
Superwoofer:	17 cm (6 ³ / ₄ ") CONE type
Impedance	4 Ω
Output sound pressure level:	80 dB/W (1.0 m)
Frequency range:	40 Hz–220 Hz (–16 dB)
	45 Hz–180 Hz (–10 dB)
Dimensions (W×H×D):	160×450×424 mm
	(6 ⁵ / ₁₆ "×17 ²³ / ₃₂ "×16 ¹¹ / ₁₆ ")
Mass:	Approx. 12 kg (26.5 lb.)

■ GENERAL

Power supply:	AC 120 V, 60 Hz
Power consumption:	Main unit [SA-HT1000] : 30 W
	Subwoofer [SB-WA351] : 290 W
Dimensions (W×H×D) (Main unit [SA-HT1000]):	430×82×381 mm (16 ¹⁵ / ₁₆ "×3 ¹ / ₄ "×15")
Mass (Main unit [SA-HT1000]):	Approx. 5.0 kg (11.0 lbs)
	(Dimensions and Mass do not include the speakers.)
Operating temperature range:	5 °C–40 °C (41 °F–104 °F)
Operating humidity range:	10 %–80 % RH (no condensation)

Power consumption in standby mode:

Main unit [SA-HT1000] :	Approx. 4.0 W
(When FL display is off:	Approx. 0.5 W)
Subwoofer [SB-WA351] :	Approx. 0.7 W

Note

Specifications are subject to change without notice.
Mass and dimensions are approximate.

Disc handling

■ How to hold a disc

Do not touch the recorded surface.

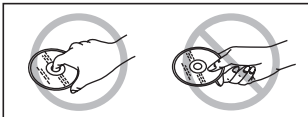

■ If there is dirt or condensation on the disc

Moisture may condense on discs after they are brought inside from the cold.

DVD-RAM and DVD-R

Clean with an optional DVD-RAM/PD disc cleaner (LF-K200DCA1, where available).

Do not use cleaners or cloths for CDs to clean DVD-RAM and DVD-R.

DVD-Audio, DVD-Video, Video CD, CD

Wipe with a damp cloth and then wipe dry.

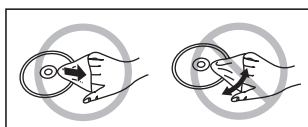

■ Handling precautions

- Do not attach labels or stickers to discs. (This may cause disc warping, rendering it unusable)
- Do not write on the label side with a ball-point pen or other writing instrument.
- Do not use record cleaning sprays, benzine, thinner, static electricity prevention liquids or any other solvent.
- Do not use scratch-proof protectors or covers.
- Do not use the following discs:
 - Discs with exposed adhesive from removed stickers or labels (rented discs etc).
 - Discs that are badly warped or cracked.
 - Irregularly shaped discs, such as heart shapes.

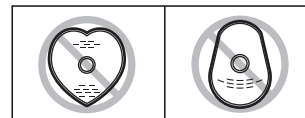

Maintenance

The precision parts in this unit are readily affected by the environment, especially temperature, humidity, and dust. Cigarette smoke also can cause malfunction or breakdown.

To clean this unit, wipe with a soft, dry cloth.

- Never use alcohol, paint thinner or benzine to clean this unit.
- Before using chemically treated cloth, read the instructions that came with the cloth carefully.

Observe the following points to ensure continued listening and viewing pleasure.

Dust and dirt may adhere to the unit's lens over time, making it impossible to record or play discs.

Use the **DVD-RAM/PD lens cleaner (LF-K123LCA1)** about once every year, depending on frequency of use and the operating environment. Read the lens cleaner's instructions carefully before use.

Product Service

- 1. Damage requiring service**—The unit should be serviced by qualified service personnel if:
 - (a) The AC power supply cord or AC adaptor has been damaged; or
 - (b) Objects or liquids have gotten into the unit; or
 - (c) The unit has been exposed to rain; or
 - (d) The unit does not operate normally or exhibits a marked change in performance; or
 - (e) The unit has been dropped or the cabinet damaged.
- 2. Servicing**—Do not attempt to service the unit beyond that described in these operating instructions. Refer all other servicing to authorized servicing personnel.
- 3. Replacement parts**—When parts need replacing ensure the servicer uses parts specified by the manufacturer or parts that have the same characteristics as the original parts. Unauthorized substitutes may result in fire, electric shock, or other hazards.
- 4. Safety check**—After repairs or service, ask the servicer to perform safety checks to confirm that the unit is in proper working condition.

The servicer will require all components to service your system.

Therefore, should service ever be necessary, be sure to bring the entire system.

Product information

For product information or assistance with product operation:

In the U.S.A., contact the Panasonic Customer Call Center at 1-800-211-7262, or e-mail consumerproducts@panasonic.com, or the website (<http://www.panasonic.com>).

In Canada, contact the Panasonic Canada Inc. Customer Care Centre at 1-800-561-5505, or visit the website (www.panasonic.ca), or an authorized Servicentre closest to you.

Limited Warranty (ONLY FOR U.S.A.)

Panasonic Consumer Electronics Company,
Division of Matsushita Electric Corporation of America
One Panasonic Way Secaucus, New Jersey 07094

Panasonic Sales Company, Division of Matsushita Electric of Puerto Rico, Inc.,
Ave. 65 de Infantería, Km. 9.5
San Gabriel Industrial Park, Carolina, Puerto Rico 00985

Panasonic/Technics Audio Products Limited Warranty

Limited Warranty Coverage

If your product does not work properly because of a defect in materials or workmanship, Panasonic Consumer Electronics Company or Panasonic Sales Company (collectively referred to as "the warrantor") will, for the length of the period indicated on the chart below, which starts with the date of original purchase ("warranty period"), at its option either (a) repair your product with new or refurbished parts, or (b) replace it with a new or a refurbished product. The decision to repair or replace will be made by the warrantor.

Product or Part Name	Parts	Labor
Audio Products (except items listed below)	One (1) year	One (1) year
All Audio Racks (cabinets)	Thirty (30) days	Not Applicable
Technics Stand Alone Speakers, Subwoofer Speakers	Three (3) years	Three (3) years
USB Reader-Writer, Personal Computer Card Adapters (in exchange for defective item)	One (1) year	Not Applicable
Accessories: Headphones, Cartridges, Microphones, Adapters	Ninety (90) days	Ninety (90) days
Rechargeable Batteries, DVD-R/-RAM Discs (in exchange for defective item)	Ten (10) days	Not Applicable
SD Memory Cards, Rechargeable Battery Packs (in exchange for defective item)	Ninety (90) days	Not Applicable

During the "Labor" warranty period there will be no charge for labor. During the "Parts" warranty period, there will be no charge for parts. You must carry-in or mail-in your product during the warranty period. If non-rechargeable batteries are included, they are not warranted. This warranty only applies to products purchased and serviced in the United States or Puerto Rico. This warranty is extended only to the original purchaser of a new product which was not sold "as is". A purchase receipt or other proof of the original purchase date is required for warranty service.

Carry-In or Mail-In Service

For Carry-In or Mail-In Service in the United States call 1-800-211-PANA (1-800-211-7262) or visit Panasonic web site: <http://www.panasonic.com>
For assistance in Puerto Rico call Panasonic Sales Company (787)-750-4300 or fax (787)-768-2910.

Limited Warranty Limits And Exclusions

This warranty ONLY COVERS failures due to defects in materials or workmanship, and DOES NOT COVER normal wear and tear or cosmetic damage. The warranty ALSO DOES NOT COVER damages which occurred in shipment, or failures which are caused by products not supplied by the warrantor, or failures which result from accidents, misuse, abuse, neglect, mishandling, misapplication, alteration, faulty installation, set-up adjustments, misadjustment of consumer controls, improper maintenance, power line surge, lightning damage, modification, or commercial use (such as in a hotel, office, restaurant, or other business), rental use of the product, service by anyone other than a Factory Servicenter or other Authorized Servicer, or damage that is attributable to acts of God.

THERE ARE NO EXPRESS WARRANTIES EXCEPT AS LISTED UNDER "LIMITED WARRANTY COVERAGE". THE WARRANTOR IS NOT LIABLE FOR INCIDENTAL OR CONSEQUENTIAL DAMAGES RESULTING FROM THE USE OF THIS PRODUCT, OR ARISING OUT OF ANY BREACH OF THIS WARRANTY. (As examples, this excludes damages for lost time, travel to and from the servicer, loss of media or images, data or other memory content. The items listed are not exclusive, but are for illustration only.) **ALL EXPRESS AND IMPLIED WARRANTIES, INCLUDING THE WARRANTY OF MERCHANTABILITY, ARE LIMITED TO THE PERIOD OF THE LIMITED WARRANTY.**

Some states do not allow the exclusion or limitation of incidental or consequential damages, or limitations on how long an implied warranty lasts, so the exclusions may not apply to you. This warranty gives you specific legal rights and you may also have other rights which vary from state to state. If a problem with this product develops during or after the warranty period, you may contact your dealer or Servicenter. If the problem is not handled to your satisfaction, then write to the warrantor's Consumer Affairs Department at the addresses listed for the warrantor.

PARTS AND SERVICE WHICH ARE NOT COVERED BY THIS LIMITED WARRANTY ARE YOUR RESPONSIBILITY.

Customer Services Directory

For Product Information, Operating Assistance, Literature Request, Dealer Locations, and Customer Service inquiries please visit Web Site:

<http://www.panasonic.com>

You can purchase parts, accessories, locate your nearest servicenter and more by visiting our Web Site or E-mail us via web:

http://www.panasonic.com/consumer_electronics/support/customerfeedback.asp

Contact:

1-800-211-PANA (7262),

Monday-Friday 9 am-9 pm; Saturday-Sunday 10 am-7 pm, EST.

For hearing or speech impaired TTY users, TTY: 1-877-833-8855

Accessory Purchases

1-800-332-5368 (Customer Orders Only)

1-800-237-9080 (Fax Only)

(Monday-Friday 9 am to 8 pm, EST.) Panasonic Services Company

20421 84th Avenue South, Kent, WA 98032

(Accepts Visa, MasterCard, Discover Card, American Express, and Personal Check)

For hearing or speech impaired TTY users, TTY: 1-866-605-1277

Service in Puerto Rico

Matsushita Electric of Puerto Rico, Inc. Panasonic Sales Company/Factory Servicenter:
Ave. 65 de Infantería, Km. 9.5, San Gabriel Industrial Park, Carolina, Puerto Rico 00985
Phone (787) 750-4300 Fax (787) 768-2910

Limited Warranty (ONLY FOR CANADA)

Panasonic Canada Inc.
5770 Ambler Drive, Mississauga, Ontario L4W 2T3

PANASONIC/TECHNICS PRODUCT—LIMITED WARRANTY

Panasonic Canada Inc. warrants this product to be free from defects in material and workmanship and agrees to remedy any such defect for a period as stated below from the date of original purchase.

Panasonic Home Theater System with DVD Recorder One (1) year, parts and labour

LIMITATIONS AND EXCLUSIONS

This warranty does not apply to products purchased outside Canada or to any product which has been improperly installed, subjected to usage for which the product was not designed, misused or abused, damaged during shipping, or which has been altered or repaired in any way that affects the reliability or detracts from the performance, nor does it cover any product which is used commercially. Dry cell batteries are also excluded from coverage under this warranty.

This warranty is extended to the original end user purchaser only. A purchase receipt or other proof of date of original purchase is required before warranty service is performed.

THIS EXPRESS, LIMITED WARRANTY IS IN LIEU OF ALL OTHER WARRANTIES, EXPRESS OR IMPLIED, EXCLUDING ANY IMPLIED WARRANTIES OF MERCHANTABILITY OR FITNESS FOR A PARTICULAR PURPOSE.

IN NO EVENT WILL PANASONIC CANADA INC. BE LIABLE FOR ANY SPECIAL, INDIRECT OR CONSEQUENTIAL DAMAGES.

In certain instances, some jurisdictions do not allow the exclusion or limitation of incidental or consequential damages, or the exclusion of implied warranties, so the above limitations and exclusions may not be applicable.

WARRANTY SERVICE

For product operation and information assistance, please contact your Dealer or our Customer Care Centre at: Telephone #: (905) 624-5505 Fax #: (905) 238-2360 Web: www.panasonic.ca

For product repairs, please contact one of the following:

- Your Dealer who will inform you of an authorized Servicentre nearest you.
- Our Customer Care Centre at (905) 624-5505 or www.panasonic.ca
- A Panasonic Factory Servicentre listed below:

Richmond, British Columbia

Panasonic Canada Inc.
12111 Riverside Way
Richmond, BC
V6W 1K8
Tel: (604) 278-4211
Fax: (604) 278-5627

Calgary, Alberta

Panasonic Canada Inc.
6835-8th St. N. E.
Calgary, AB
T2E 7H7
Tel: (403) 295-3955
Fax: (403) 274-5493

Mississauga, Ontario

Panasonic Canada Inc.
5770 Ambler Dr.
Mississauga, ON
L4W 2T3
Tel: (905) 624-8447
Fax: (905) 238-2418

Lachine, Québec

Panasonic Canada Inc.
3075, rue Louis A. Amos
Lachine, QC
H8T 1C4
Tel: (514) 633-8684
Fax: (514) 633-8020

IF YOU SHIP THE PRODUCT TO A SERVICENTRE

Carefully pack and send prepaid, adequately insured and preferably in the original carton.
Include details of the defect claimed, and proof of date of original purchase.

Angle	22	Finalize	33	Seat position	37
Antenna system	40	Flexible Recording (FR)	12, 13	SETUP menu	38–43
Audio	13, 19	Format	33	Shorten Segment	31
Audio attribute	22	FUNCTIONS window	25	Simultaneous rec and play	17
Center Focus	36	Headphones	7	Sound Field Control	36
Channel Caption	41	Language code list	50	Sound track	22
Channel Setting		LPCM	12, 51	Speaker delay time	42
Auto Channel Setting	40	Marker	18, 23	Speaker level adjustment	37
Plug-in Auto Tuning	9	MP3	21	Subtitle	22
Chasing Play	17	MPEG-DNR	23	Subwoofer level	37
Cleaning		Multi Rear Surround	37	Television operation	11
Disc	53	Muting	6	Time Slip	17, 20
Lens	53	On-screen display	24	Timer recording	14–16
Unit	53	On-screen menu	22	Transfer	23
Clock setting	43	Picture	23	TV Type	11
CM Skip	20	Play list	27–29	VCR Plus+	
Connection		Position Memory	19	Guide channel setting	10
Audio equipment	45	Progressive	11, 23, 51	Recording	14
Cable TV box/satellite receiver	44	Properties		Virtual Rear Surround	37
Optical connection	45	Play list	28		
Video equipment	44	Program	30		
CPRM	8, 51	Protection			
Dialog Enhancer	22	Cartridge	8		
Digital audio reception	45	Disc	32		
Direct Navigator	19	Program	30		
Divide Program	31	Quick View	20		
Dolby Digital	36, 51	Radio	34		
Dolby Pro Logic II	36, 51	FM frequency step	34		
DTS	36, 51	Optional FM antenna connection	35		
Dynamic range compression	39, 45	Ratings	38		
Edit Scenes	29	Recording mode	12		
Enter title	26	Re-initialize Setting	38		
Disc	32	Remote control code	42		
Play list	28	Repeat play	23		
Program	30	Resume play function	18		
Erase	18				
All programs	32				
Play list	28				
Play list scene	29				
Program	30				

Manufactured under license from Dolby Laboratories. "Dolby", "Pro Logic" and the double-D symbol are trademarks of Dolby Laboratories.

Manufactured under license from Digital Theater Systems, Inc. US Pat. No. 5,451,942, 5,956,674, 5,974,380, 5,978,762 and other world-wide patents issued and pending. "DTS" and "DTS Digital Surround" are registered trademarks of Digital Theater Systems, Inc. Copyright 1996, 2000 Digital Theater Systems, Inc. All rights reserved.

Apparatus Claims of U.S. Patent Nos. 4,631,603, 4,577,216, and 4,819,098, licensed for limited viewing uses only.

This product incorporates copyright protection technology that is protected by method claims of certain U.S. patents and other intellectual property rights owned by Macrovision Corporation and other rights owners. Use of this copyright protection technology must be authorized by Macrovision Corporation, and is intended for home and other limited viewing uses only unless otherwise authorized by Macrovision Corporation. Reverse engineering or disassembly is prohibited.

Panasonic Consumer Electronics Company, Division of Matsushita Electric Corporation of America
 One Panasonic Way Secaucus,
 New Jersey 07094
<http://www.panasonic.com>

Panasonic Sales Company, Division of Matsushita Electric of Puerto Rico, Inc. ("PSC")
 Ave. 65 de Infantería, Km. 9.5
 San Gabriel Industrial Park, Carolina,
 Puerto Rico 00985

Panasonic Canada Inc.
 5770 Ambler Drive
 Mississauga, Ontario
 L4W 2T3
www.panasonic.ca