

The illustration shows SC-HT740.



Operating Instructions

DVD Home Theater Sound System

Model No. **SC-HT740/SC-HT940/
SC-HT743**

Region number

The player plays DVD-Video marked with labels containing the region number "1" or "ALL".

Example:



U.S.A. and Canada



As an ENERGY STAR® Partner,*
Panasonic has determined that
this product meets the ENERGY STAR®
guidelines for energy efficiency.

* For Canada only: The word "Participant" is used in place of the word "Partner".



*High-quality
picture*

page **8**

HDMI capability, Advanced
progressive scan and more.

U.S.A. and Canada

*Wireless-ready
surround sound*

page **8**

Optional wireless surround
speaker connection.

*High-performance
sound effects*

page **28**

Sound quality enhancement,
Bass enhancement and more.

**Before connecting, operating or adjusting this product,
please read the instructions completely.
Please keep this manual for future reference.**

**If you have any questions contact
In the U.S.A.: 1-800-211-PANA (7262)
In Canada: 1-800-561-5505**

Dear customer

Thank you for purchasing this product. For optimum performance and safety, please read these instructions carefully.

- These operating instructions are applicable to models SC-HT740, SC-HT743 and SC-HT940 for a variety of regions.
- Unless otherwise indicated, illustrations in these operating instructions are of SC-HT740 for U.S.A. and Canada.
- Operations in these instructions are described mainly with the remote control, but you can perform the operations on the main unit if the controls are the same.

HT740 : indicates features applicable to SC-HT740 only.

HT743 : SC-HT743 only.

HT940 : SC-HT940 only.

System	SC-HT740	SC-HT743	SC-HT940
Main unit	SA-HT740	SA-HT743	SA-HT940
Front speakers	SB-FS740	SB-FS740	SB-FS940
Center speaker	SB-PC740	SB-PC740	SB-PC940
Surround speakers	SB-FS741	SB-FS741	SB-FS941
Subwoofer	SB-W740	SB-W740	SB-W940

CAUTION!

THIS PRODUCT UTILIZES A LASER.
 USE OF CONTROLS OR ADJUSTMENTS OR PERFORMANCE OF PROCEDURES OTHER THAN THOSE SPECIFIED HEREIN MAY RESULT IN HAZARDOUS RADIATION EXPOSURE.
 DO NOT OPEN COVERS AND DO NOT REPAIR YOURSELF.
 REFER SERVICING TO QUALIFIED PERSONNEL.

WARNING:

TO REDUCE THE RISK OF FIRE, ELECTRIC SHOCK OR PRODUCT DAMAGE, DO NOT EXPOSE THIS APPARATUS TO RAIN, MOISTURE, DRIPPING OR SPLASHING AND THAT NO OBJECTS FILLED WITH LIQUIDS, SUCH AS VASES, SHALL BE PLACED ON THE APPARATUS.

THE FOLLOWING APPLIES ONLY IN THE U.S.A.

FCC Note:

This equipment has been tested and found to comply with the limits for a Class B digital device, pursuant to Part 15 of the FCC Rules. These limits are designed to provide reasonable protection against harmful interference in a residential installation. This equipment generates, uses and can radiate radio frequency energy and, if not installed and used in accordance with the instructions, may cause harmful interference to radio communications. However, there is no guarantee that interference will not occur in a particular installation. If this equipment does cause harmful interference to radio or television reception, which can be determined by turning the equipment off and on, the user is encouraged to try to correct the interference by one or more of the following measures:

- Reorient or relocate the receiving antenna.
- Increase the separation between the equipment and receiver.
- Connect the equipment into an outlet on a circuit different from that to which the receiver is connected.
- Consult the dealer or an experienced radio/TV technician for help.

Any unauthorized changes or modifications to this equipment would void the user's authority to operate this device.

This device complies with Part 15 of the FCC Rules. Operation is subject to the following two conditions: (1) This device may not cause harmful interference, and (2) this device must accept any interference received, including interference that may cause undesired operation.

Responsible Party:
 Panasonic Corporation of North America
 One Panasonic Way
 Secaucus, NJ 07094
 Telephone No.: 1-800-211-7262

CAUTION!

- DO NOT INSTALL OR PLACE THIS UNIT IN A BOOKCASE, BUILT-IN CABINET OR IN ANOTHER CONFINED SPACE. ENSURE THE UNIT IS WELL VENTILATED. TO PREVENT RISK OF ELECTRIC SHOCK OR FIRE HAZARD DUE TO OVERHEATING, ENSURE THAT CURTAINS AND ANY OTHER MATERIALS DO NOT OBSTRUCT THE VENTILATION VENTS.
- DO NOT OBSTRUCT THE UNIT'S VENTILATION OPENINGS WITH NEWSPAPERS, TABLECLOTHS, CURTAINS, AND SIMILAR ITEMS.
- DO NOT PLACE SOURCES OF NAKED FLAMES, SUCH AS LIGHTED CANDLES, ON THE UNIT.
- DISPOSE OF BATTERIES IN AN ENVIRONMENTALLY FRIENDLY MANNER.

The socket outlet shall be installed near the equipment and easily accessible. The mains plug of the power supply cord shall remain readily operable.

To completely disconnect this apparatus from the AC Mains, disconnect the power supply cord plug from AC receptacle.

THE FOLLOWING APPLIES ONLY IN THE U.S.A. AND CANADA



CAUTION

RISK OF ELECTRIC SHOCK
DO NOT OPEN



CAUTION: TO REDUCE THE RISK OF ELECTRIC SHOCK, DO NOT REMOVE SCREWS. NO USER-SERVICEABLE PARTS INSIDE. REFER SERVICING TO QUALIFIED SERVICE PERSONNEL.



The lightning flash with arrowhead symbol, within an equilateral triangle, is intended to alert the user to the presence of uninsulated "dangerous voltage" within the product's enclosure that may be of sufficient magnitude to constitute a risk of electric shock to persons.



The exclamation point within an equilateral triangle is intended to alert the user to the presence of important operating and maintenance (servicing) instructions in the literature accompanying the appliance.

IMPORTANT SAFETY INSTRUCTIONS

Read these operating instructions carefully before using the unit. Follow the safety instructions on the unit and the applicable safety instructions listed below. Keep these operating instructions handy for future reference.

- 1) Read these instructions.
- 2) Keep these instructions.
- 3) Heed all warnings.
- 4) Follow all instructions.
- 5) Do not use this apparatus near water.
- 6) Clean only with dry cloth.
- 7) Do not block any ventilation openings. Install in accordance with the manufacturer's instructions.
- 8) Do not install near any heat sources such as radiators, heat registers, stoves, or other apparatus (including amplifiers) that produce heat.
- 9) **U.S.A. and Canada**
Do not defeat the safety purpose of the polarized or grounding-type plug. A polarized plug has two blades with one wider than the other. A grounding-type plug has two blades and a third grounding prong. The wide blade or the third prong are provided for your safety. If the provided plug does not fit into your outlet, consult an electrician for replacement of the obsolete outlet.
- 10) Protect the power cord from being walked on or pinched particularly at plugs, convenience receptacles, and the point where they exit from the apparatus.
- 11) Only use attachments/accessories specified by the manufacturer.
- 12) Use only with the cart, stand, tripod, bracket, or table specified by the manufacturer, or sold with the apparatus. When a cart is used, use caution when moving the cart/apparatus combination to avoid injury from tip-over.
- 13) Unplug this apparatus during lightning storms or when unused for long periods of time.
- 14) Refer all servicing to qualified service personnel. Servicing is required when the apparatus has been damaged in any way, such as power-supply cord or plug is damaged, liquid has been spilled or objects have fallen into the apparatus, the apparatus has been exposed to rain or moisture, does not operate normally, or has been dropped.



TABLE OF CONTENTS

Getting Started



IMPORTANT SAFETY INSTRUCTIONS 2

Simple Setup

STEP 1 Assembling the front speakers 4
Speaker installation options 6

STEP 2 Positioning the speakers 7

STEP 3 Speaker connections 8

STEP 4 Audio and video connections 8
Television with an HDMI terminal 8
Basic audio connection 9
Basic video connection 9

STEP 5 Radio and AC cord connections 10

STEP 6 Preparing the remote control 10

STEP 7 Performing QUICK SETUP 11

Control reference guide 11

Discs that can be played 12

Disc caution 12

Maintenance 12

Product Service 13

Glossary 13



Playing Discs



Basic play 14

Using the main unit 14

Using the remote control 15

Convenient functions 16

Checking the disc type in each tray 16

Displaying current playback condition 16

Playing CDs sequentially 16

Changing the zoom ratio 16

Repeat play 16

Program and Random play 17

Playing data discs using navigation menus 18

Playing data discs 18

Selecting a track using CD text 18

Playing HighMAT™ discs 19

Playing RAM and DVD-R/RW (DVD-VR) discs 19

Using on-screen menus 20

Main menu 20

Other Settings 21

Changing the player settings 23

Changing the delay time of the speakers 25



Other Operations



Using the radio 26

Presetting stations automatically 26

Selecting the preset channels 26

Manual tuning 26

Using an outdoor antenna (optional) 27

Using sound effects 28

Changing the sound quality: Sound Field Control 28

Enhancing the sound from the center speaker:

Center Focus 28

Enhancing the stereo sound: Dolby Pro Logic II 28

HT940 Enhancing the surround sound effect:

Surround Enhancer 28

Enhancing the bass sound: H.BASS 29

Adjusting the amount of bass: Subwoofer level 29

Adjusting the volume of each speaker:

Speaker level adjustments 29

Operating other equipment 30

Operating the television 30

Changing the remote control code 30

HT940 Operating both the television and the home theater system: Control with HDMI (HDAVI Control™) 30

Using other useful functions 31

Setting the sleep timer 31

Muting the sound 31

Using headphones 31

Using the Music Port 31



Reference



Troubleshooting guide 32

Specifications 35

Limited Warranty (ONLY FOR U.S.A.) 37

Limited Warranty (ONLY FOR CANADA) 38

Accessories Back cover



STEP 1

Assembling the front speakers

The supplied stands are specially designed for attachment to Panasonic SB-FS740 or SB-FS940 front speakers. Use only as indicated in this setup.

Preparation

- To prevent damage or scratches, lay down a soft cloth and perform assembly on it.
- For assembly, use a Phillips-head screwdriver.
- Make sure you have all the indicated components before starting assembly, setup, and connection.
- There is no difference between the right and left speakers and stands.
- For optional wall mount, refer to page 6.

HT740 HT743

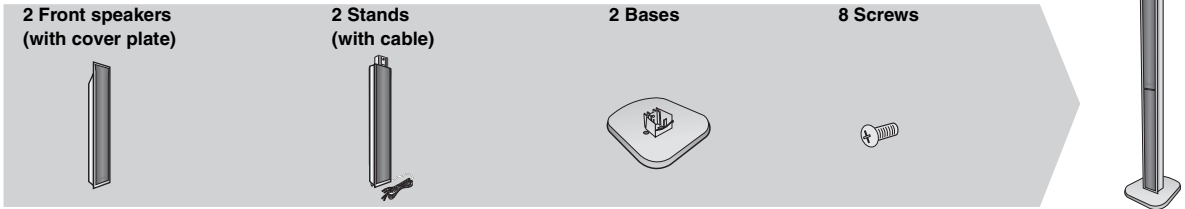

1 Attach the stand to the base.

① Thread the speaker cable through the base.

For quicker threading, loosely fold the cable in half (do not crease), pass the folded portion through the hole, and then pull the rest of the cable through the base.

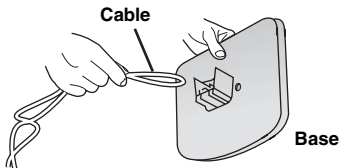

② Attach the stand to the base while gently pulling on the end of the speaker cable.

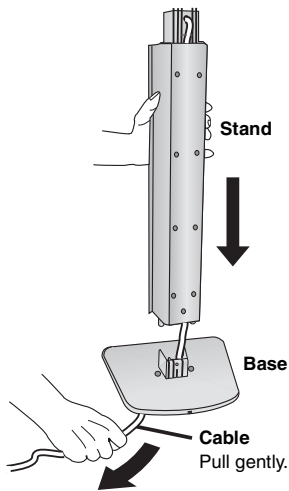

2 Secure the stand to the base.

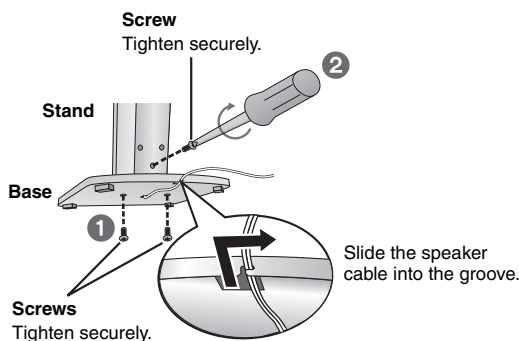

3 Attach the speaker to the stand.

① Pull out the end of the speaker cable and position it between the ridges.

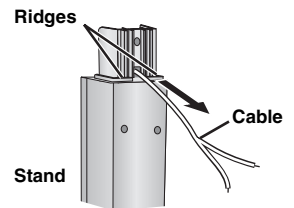

② Attach the speaker to the stand.

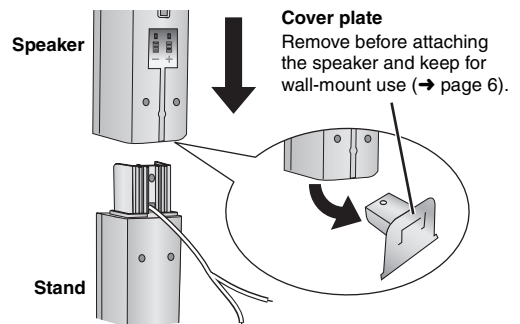

4 Secure the speaker to the stand.

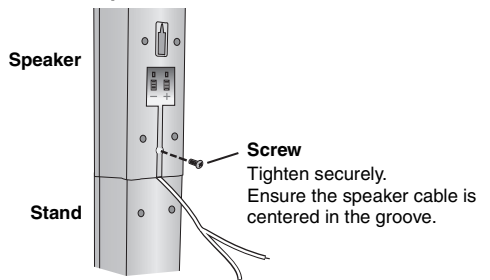

5 Connect the speaker cable.

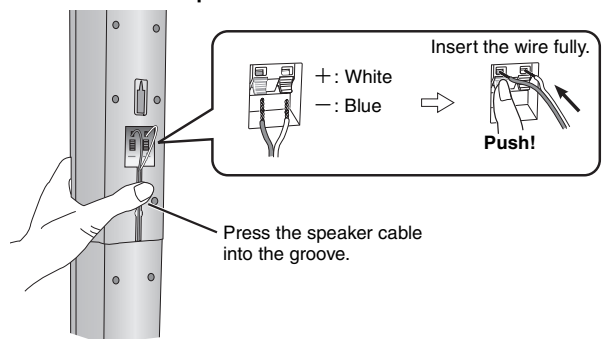

2 Front speakers

2 Stands (with cable)

2 Bases

6 Screws

2 Sliders

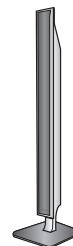

The speaker height can be adjusted.

Min: 110 cm (43¹/₄"")
Max: 135 cm (53⁵/₃₂"")

1 Attach the speaker to the stand.

Place the polyfoam underneath the speaker for stability while attaching the speaker to the stand.

- ① Feed the speaker cable (the shorter part) into the bottom of the speaker and through the slot at the rear.
- ② While pulling the speaker cable up through the slot, slide the speaker stand into the bottom of the speaker.

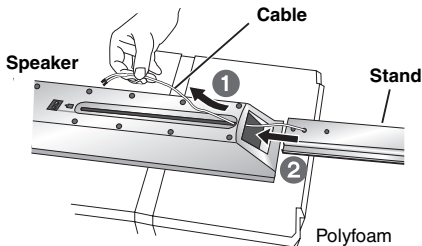

- ③ Thread the cable through the middle hole of the slider and fasten the slider with the two screws.

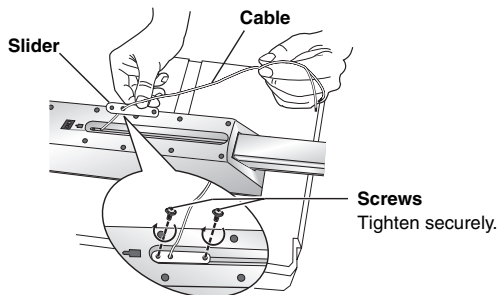

2 Attach the stand to the base.

- ① Thread the speaker cable through the base. For quicker threading, loosely fold the cable in half (do not crease), pass the folded portion through the hole, and then pull the rest of the cable through the base.

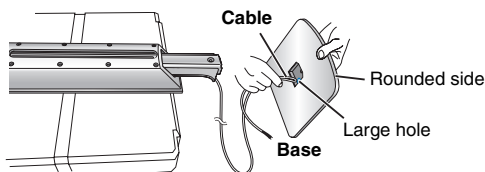

- ② Insert the stand into the base while gently pulling on the end of the cable.

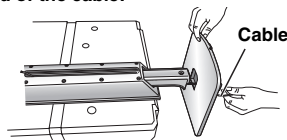

3 Secure the stand to the base.

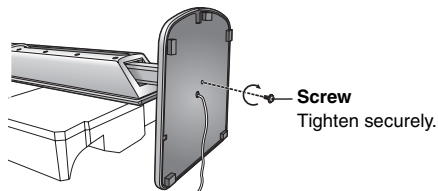

4 Adjust the speaker height.

- ① Loosen the screws until the speaker can slide up and down the stand.
- ② Raise the speaker to the desired height, and then re-tighten the screws.

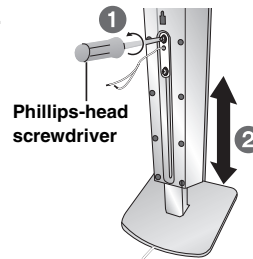

5 Connect the speaker cable.

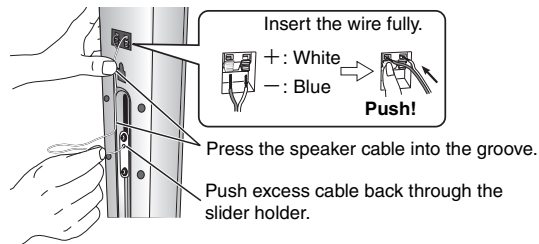

6 Secure the speaker cable to the base.

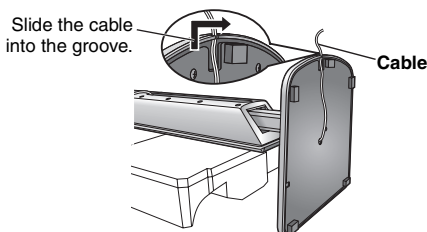

Preventing the speakers from falling

- You will need to obtain the appropriate screw eyes to match the walls or pillars to which they are going to be fastened.
- Consult a qualified housing contractor concerning the appropriate procedure when attaching to a concrete wall or a surface that may not have strong enough support. Improper attachment may result in damage to the wall or speakers.

e.g. HT740 HT743 String (not included) Thread from the wall to the speaker and tie tightly.

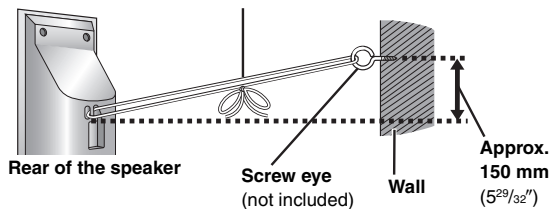

Speaker installation options

■ Attaching to a wall

- You can attach all of the speakers (except subwoofer) to a wall.
- The wall or pillar on which the speakers are to be attached should be capable of supporting over 10 kg (22 lbs) [HT940 15 kg (33 lbs) for the front speakers] per screw. Consult a qualified building contractor when attaching the speakers to a wall. Improper attachment may result in damage to the wall and speakers.
 - When mounting the front speakers to a wall, we recommend using a string (not included) to prevent it from falling.

2 Screws HT740 HT743 2 Cover plates HT740 HT743

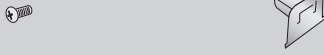

Preparation for front speakers

HT740 HT743

- 1 Remove the speaker cable from the stand.

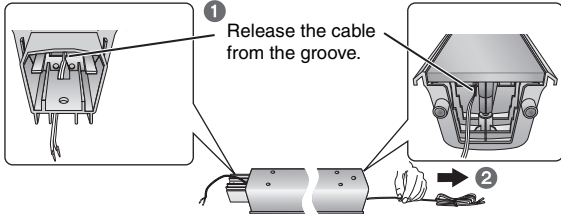

- 2 Connect the cable (→ page 4).

HT940

- 1 Pull down the longer part of the cable to release the cable from the groove inside the stand, and then pull the speaker cable out from the stand.
- 2 Feed the cable into the bottom of the speaker and through the slot at the rear.
- 3 Connect the cable (→ page 5).

- ① HT740 HT743 Attach the cover plate to the front speaker.

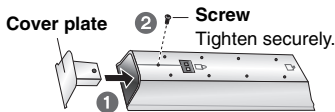

- ② Drive a screw (not included) into the wall.

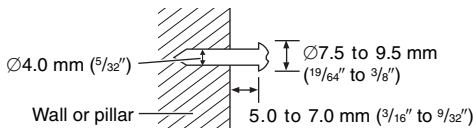

- ③ Fit the speaker securely onto the screw(s) with the hole(s).

Front speaker HT740 HT743

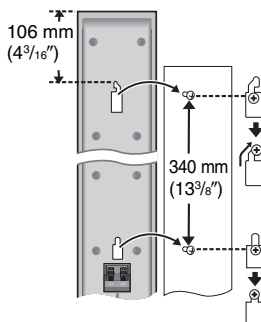

Center speaker HT740 HT743

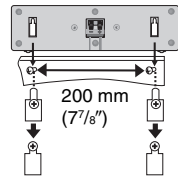

Surround speaker HT740 HT743

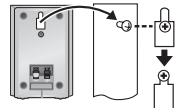

Front speaker HT940

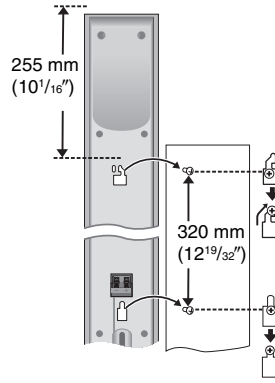

Center speaker HT940

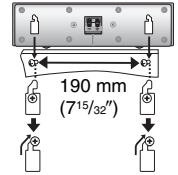

Surround speaker HT940

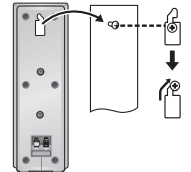

e.g. In this position, the speaker will likely fall if moved to the left or right.

Move the speaker so that the screw is in this position.

Reattaching the speaker cable to the stand

HT740 HT743

- 1 Remove the eight screws from the stand, and remove the speaker net.

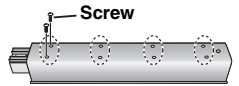

- 2 Position the cable.

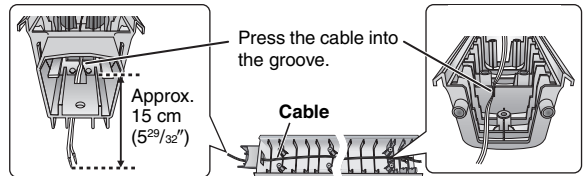

- 3 Attach the speaker net with the screws.

HT940

- 1 Remove the two screws from the stand, and remove the metal cover.

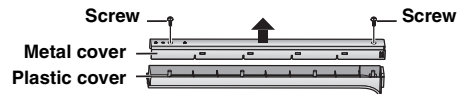

- 2 Pull the cable out about 40 cm (15 3/4") from the hole in the metal cover, and insert the plastic cover.

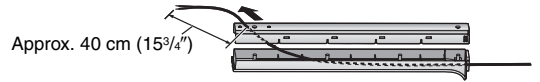

- 3 Insert the metal cover so it does not disturb the cable and close tightly with the two screws.



■ Fitting speaker stands (not included)

(Except front speakers)

Ensure the stands meet these conditions before purchasing them. Note the diameter and length of the screws and the distance between screws as shown in the diagram.

- The stands must be able to support over 10 kg (22 lbs).
- The stands must be stable even if the speakers are in a high position.

e.g. Center speaker HT740 HT743

Metal screw holes

For attaching to speaker stands

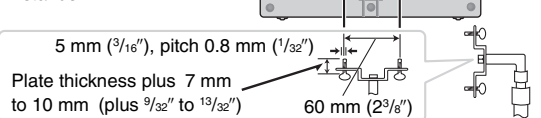

Speaker stand (not included)

STEP 2 Positioning the speakers

How you set up your speakers can affect the bass and the sound field. Note the following points:

- Place speakers on flat secure bases.
- Placing speakers too close to floors, walls, and corners can result in excessive bass. Cover walls and windows with thick curtains.
- Left and right speakers are interchangeable, but front and surround speakers are not.

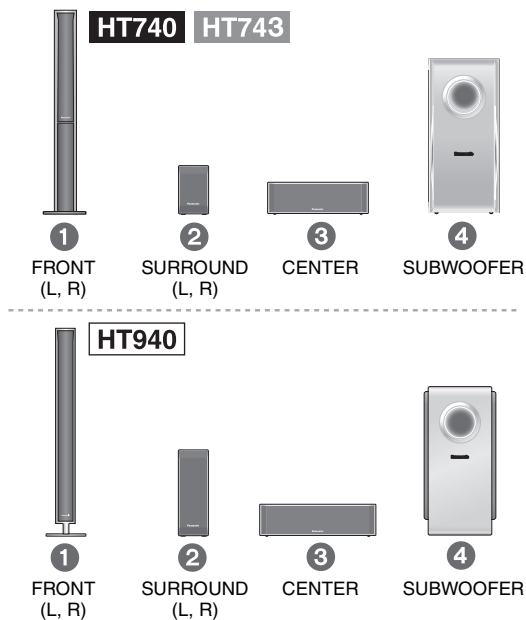

Setup example

Place the front, center, and surround speakers at approximately the same distance from the seating position. The angles in the diagram are approximate.

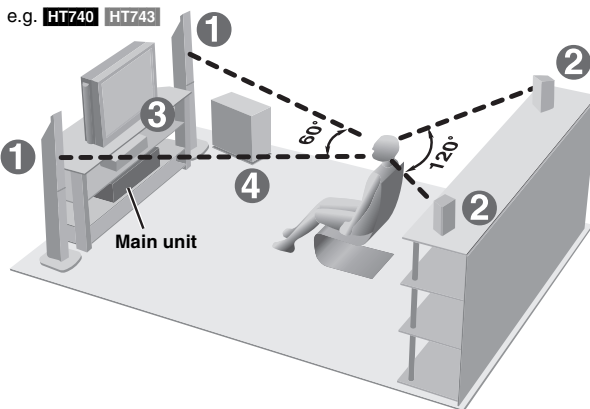

Use only supplied speakers

- Using other speakers can damage the unit, and sound quality will be negatively affected.
- Set the speakers up on an even surface to prevent them from falling. Take proper precautions to prevent the speakers from falling if you cannot set them up on an even surface.

Main unit

Note

- Keep your speakers at least 10 mm ($13/32$ ") away from the system for proper ventilation.
- To allow for proper ventilation and to maintain good airflow around the main unit, position it with at least 5 cm (2") of space on all sides.
- Do not block the ventilation holes of the main unit.

Center speaker

- Vibration caused by the center speaker can disrupt the picture if it is placed directly on the television. Put the center speaker on a rack or shelf.
- To prevent the speakers from falling, do not place directly on top of the television.

Subwoofer

Place to the right or left of the television, on the floor or a sturdy shelf so that it will not cause vibration. Leave about 30 cm ($11^{13}/16$ ") from the television.

Caution

- Do not stand on the base. Be cautious when children are near.

e.g. HT740 HT743 Front speaker



- Do not touch the netted area of the speakers.

e.g. HT740 HT743 Surround speaker



Notes on speaker use

- You can damage your speakers and shorten their useful life if you play sound at high levels over extended periods.
- Reduce the volume in the following cases to avoid damage:
 - When playing distorted sound.
 - When the speakers are reverberating due to a record player, noise from FM broadcasts, or continuous signals from an oscillator, test disc, or electronic instrument.
 - When adjusting the sound quality.
 - When turning the unit on or off.

If irregular coloring occurs on your television

The front and center speakers are designed to be used close to a television, but the picture may be affected with some televisions and setup combinations.

If this occurs, turn the television off for about 30 minutes.

The demagnetizing function of the television should correct the problem. If it persists, move the speakers further away from the television.

Caution

- The main unit and supplied speakers are to be used only as indicated in this setup. Failure to do so may lead to damage to the amplifier and/or the speakers, and may result in the risk of fire. Consult a qualified service person if damage has occurred or if you experience a sudden change in performance.
- Do not attempt to attach these speakers to walls using methods other than those described in this manual.

STEP 3 Speaker connections

- Ensure the AC cord is disconnected before you make the speaker connections.

Speaker cables

- **HT740** / **HT743** 1×short cable: For center speaker
- **HT940** 2×short cables: For center speaker and subwoofer
- 2×long cables: For surround speakers

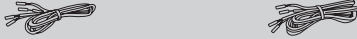

2 sheets of speaker cable stickers

- Attach the speaker-cable stickers to make connection easier.



The illustration shows SC-HT740 for U.S.A. and Canada.

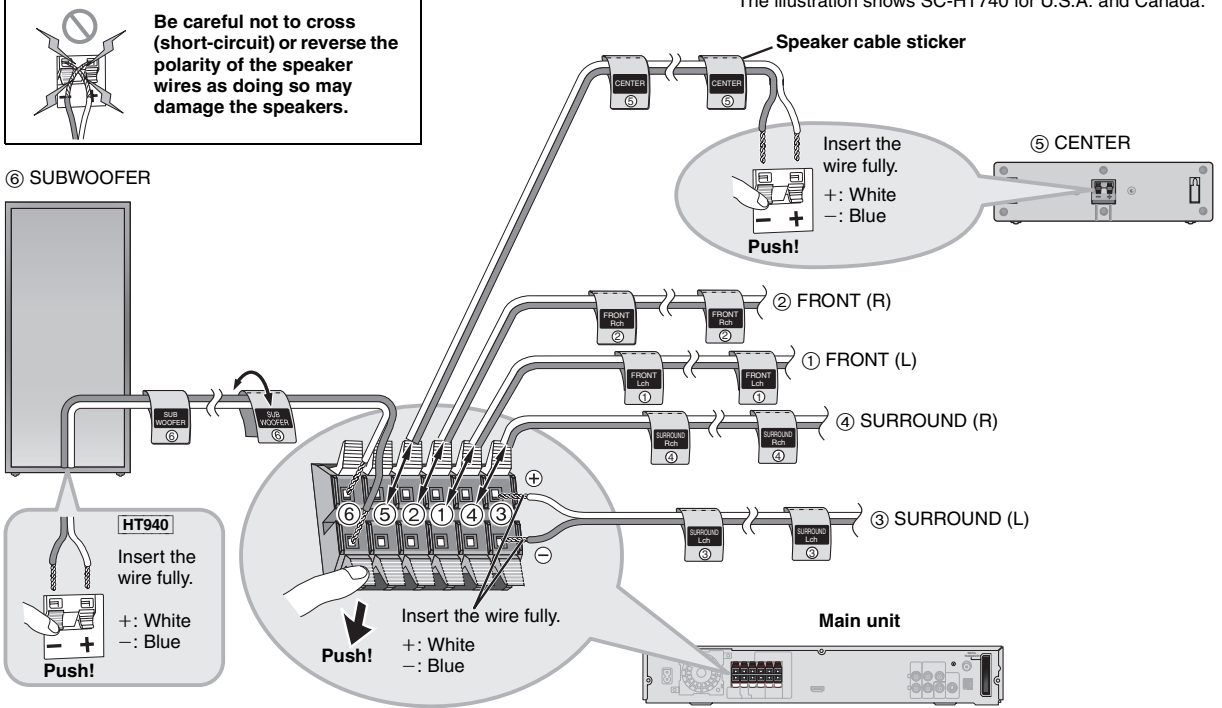

For U.S.A. and Canada only

Set your surround sound free! Optional Panasonic wireless accessory (e.g. SH-FX60)

You can enjoy surround speaker sound wirelessly when you use the optional Panasonic wireless accessory (e.g. SH-FX60). For details, please refer to the operating instructions for the optional Panasonic wireless accessory.

STEP 4 Audio and video connections

- Do not connect through the video cassette recorder.
Due to copy guard protection, the picture may not be displayed properly.
- Turn the television off before connecting, and refer to the television's operating instructions.

Video cable



Television with an HDMI terminal

HDMI-compatible television
(not included)

Back of the main unit



HDMI cable (not included)

Note

- It is recommended that you use Panasonic's HDMI cable.
[Recommended part number: RP-CDHG15 (1.5 m/4.9 ft), RP-CDHG30 (3.0 m/9.8 ft), RP-CDHG50 (5.0 m/16.4 ft), etc.]
- Non-HDMI-compliant cables cannot be utilized.

HT940

Control with HDMI (HDAVI Control)

If your Panasonic television is an HDMI control compatible television, you can operate your television synchronizing with home-theater operations or vice versa (→ page 30, **HT940** Operating both the television and the home theater system: Control with HDMI (HDAVI Control™)).

- Make the extra audio connection (→ page 9) when you use HDAVI Control function.

Use the HDMI connection to enjoy higher quality audio and video with a single cable (→ page 13, HDMI).

By connecting to an HDMI-compatible high-definition television, you can enjoy high-definition video (720p or 1080i) with 2-channel audio.

- Set "Video Output" to "On" and "Audio Output" to "On" (→ page 24, "HDMI" tab).
- Set "Video Output Mode" (→ page 21, Picture Menu).

Basic audio connection

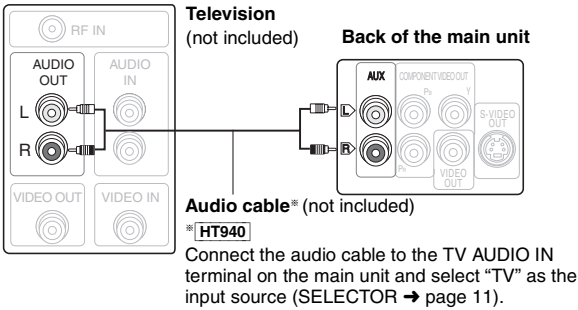

- This audio connection will enable you to play audio from your television through your home theater system. Refer to "Operating other equipment" (→ page 30).

Basic video connection

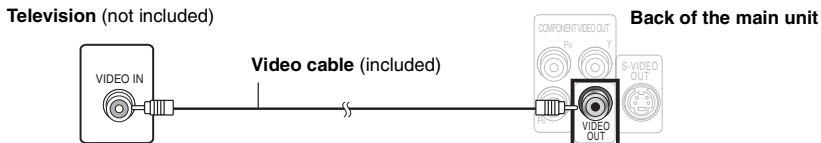

Other video connections for improved picture quality

COMPONENT VIDEO OUT

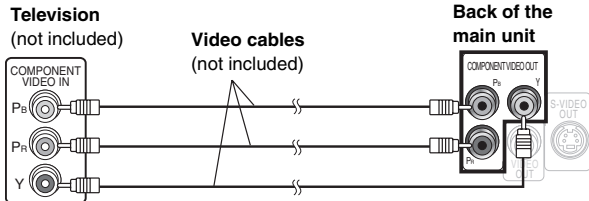

• Using the COMPONENT VIDEO OUT terminals

The COMPONENT VIDEO OUT terminals provides a purer picture than the S-VIDEO OUT terminal. These terminals can be used for either interlaced or progressive output. Connection using these terminals outputs the color difference signals (P_b/P_r) and luminance signal (Y) separately in order to achieve high fidelity in reproducing colors.

- The description of the component video input terminals depends on the television or monitor (e.g. Y/P_b/P_r, Y/B-Y/R-Y, Y/C_b/C_r). Connect to terminals of the same color.
- After making this connection, select "Darker" from the "Black Level Control" in the "Video" tab (→ page 24).

To enjoy progressive video

- Connect to a progressive output compatible television.
 - ① Set "Video Output" to "Off" (→ page 24, "HDMI" tab).
 - ② Set "Video Output Mode" to "480p", and then follow the instructions on the menu screen (→ page 21, Picture Menu).
- All Panasonic televisions that have 480p input connectors are compatible. Consult the manufacturer if you have another brand of television.

S-VIDEO OUT

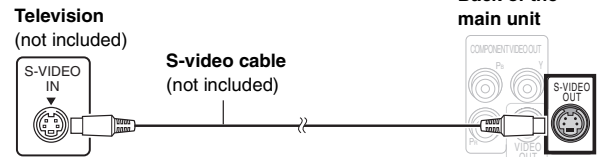

• Using the S-VIDEO OUT terminal

The S-VIDEO OUT terminal achieves a more vivid picture than the VIDEO OUT terminal by separating the chrominance (C) and luminance (Y) signals. (Actual results depend on the television.)

■ Cable TV box or video cassette recorder connection

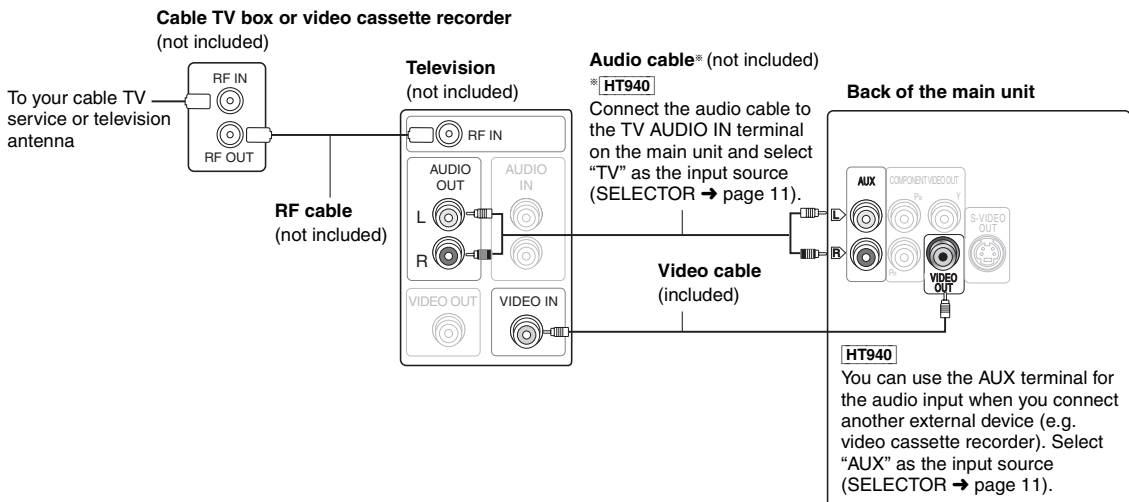

STEP 5 Radio and AC cord connections

AM loop antenna



FM indoor antenna



AC power supply cord

U.S.A. and Canada



Others



Power plug adaptor

Areas except U.S.A. and Canada



- Connect the AC power supply cord after all other connections are complete.
- Using an outdoor antenna (optional) (→ page 27).

The illustration shows SC-HT740 for U.S.A. and Canada.

AM loop antenna

Stand the antenna up on its base.
Place the antenna where reception is best.
Keep loose antenna cable away from other wires and cables.

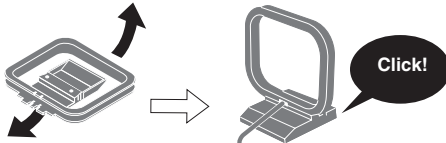

For areas except U.S.A. and Canada
Before connecting the AC power supply cord
Set the voltage.

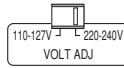

Use a flat-head screwdriver to move the voltage selector to the appropriate position for the area in which this system is used.

FM indoor antenna

Affix this end of the antenna where reception is best.

Adhesive tape

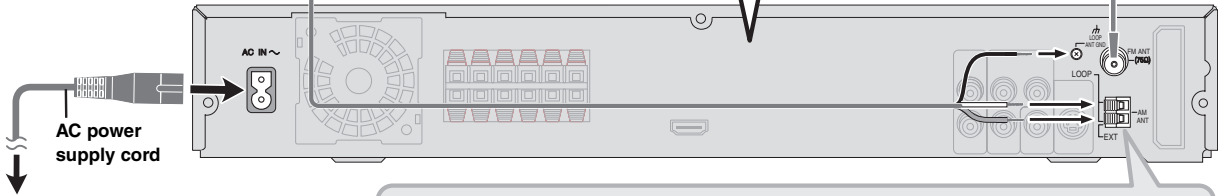

To household AC outlet

For areas except U.S.A. and Canada

- If the power plug does not fit your AC outlet
Use the power plug adaptor (included).

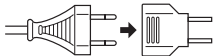

If it still does not fit, contact an electrical parts distributor for assistance.

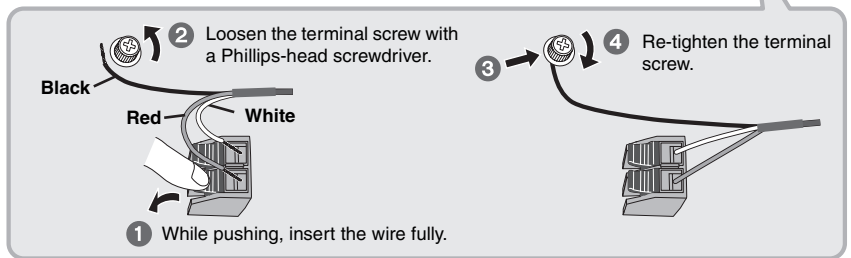

Conserving power

The main unit consumes a small amount of power, even when it is turned off (For U.S.A. and Canada: approx. 0.4 W or for other areas: approx. 0.9 W). To save power when the unit is not to be used for a long time, unplug it from the household AC outlet.

You will need to reset some memory items after plugging in the unit.

Note

The included AC power supply cord is for use with this unit only. Do not use it with other equipment. Also, do not use cords for other equipment with this unit.

STEP 6 Preparing the remote control

Remote control

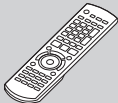

Batteries



- 2 Insert so the poles (+ and -) match those in the remote control.

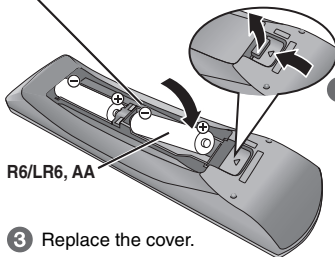

- 1 Press in and lift up.

R6/LR6, AA

- Do not use rechargeable type batteries.

- 3 Replace the cover.

Do not:

- mix old and new batteries.
- use different types at the same time.
- heat or expose to flame.
- take apart or short circuit.
- attempt to recharge alkaline or manganese batteries.
- use batteries if the covering has been peeled off.

Mishandling of batteries can cause electrolyte leakage which can severely damage the remote control.

Remove the batteries if the remote control is not going to be used for a long period of time. Store in a cool, dark place.

Use

Aim at the display (→ page 11), avoiding obstacles, at a maximum range of 7 m (23 feet) directly in front of the unit.

STEP 7

Performing QUICK SETUP

The QUICK SETUP screen assists you to make necessary settings.

To display the picture from the main unit, turn on your television and change its video input mode (e.g. VIDEO 1, AV 1, etc.).

- To change your television's video input mode, refer to its operating instructions.
- This remote control can perform some basic television operations (→ page 30).

1	2	3	4	5	6
			 Select Register		
Turn on the unit.	Select "DVD/CD".	Show the QUICK SETUP screen.	Follow the messages and make the settings.	Press to finish QUICK SETUP.	Press to exit.

To change these settings later

Select "QUICK SETUP" in the "Others" tab (→ page 24).

Control reference guide

See page references in parentheses.

Turn the unit on/off (11)
 Select the source DVD/CD (11), FM/AM (26), AUX (30)/FRONT MUSIC P./REAR MUSIC P.* (31)
 Select disc's title numbers etc./Enter numbers (15)
 Select the disc or show disc information (16)
 Select preset radio stations (26)
 Basic operations for play (14, 15)
 Select a group of contents to play (15)
 Equalizing the sound (14)
 Show a disc top menu (18) or program list (19)
 Show a disc menu (18) or play list (19)

Television operations (30)
 Change the television's video input mode (30)
 Adjust the television volume (30)
 Select television channels (30)
 Adjust the volume of the main unit (15)
 Enhance the surround sound (28)
 Start up and play a disc automatically/Control both the home theater system and the television (30)
 Equalizing the sound (14)
 Display current playback condition (16)
 Frame-by-frame/Select or register menu items on the television screen (15)
 Show on-screen menu (20)
 Return to previous screen (15)

CANCEL (15)	PLAY MODE (17)	REPEAT (16)	CD MODE (16)
SUB WOOFER LEVEL (29)	SFC (28)	□□PLII (28)	H.BASS (29)
SLEEP (31)	ZOOM (16)	FL DISPLAY (15)	C.FOCUS (28)
SETUP (23)	TEST (29)	CH SELECT (29)	MUTING (31)

Standby/on switch [POWER 0/I]

Press to switch the unit from on to standby mode or vice versa. In standby mode, the unit is still consuming a small amount of power. (14)

MUSIC PORT
 Connect an external device (31)

SURROUND MUSIC
 Equalizing the sound (14)

5 DISC SELECTOR
 Select the disc tray (14)

■ / - TUNE MODE / - FM MODE
 Stop playing (14)/Select the tuning mode (26)
 Adjust the FM reception condition (26)

► / MEMORY
 Play discs (14)/Memorize the receiving radio stations (26)

▲ OPEN/CLOSE
 Open/Close the disc drawer (14)

DISC EXCHANGE
 Open the disc drawer to exchange the disc in the play position (14)

DISC SKIP
 Skip to the next disc tray (14)

Phones
 Connect headphones (31)

Jog LED







VOLUME
 Turn up/down the volume (14)

SELECTOR (26)
 DVD/CD → FM → AM → (HT940 TV) → AUX → FRONT MUSIC P. → REAR MUSIC P.* → Return to DVD/CD

*Refer to page 31, Using the Music Port.

Discs that can be played

Operations in these instructions are described mainly with formats. Icons such as **DVD-V** show the formats.

	DVD-Video DVD-V —
	DVD-Audio DVD-A DVD-V • DVD-V Some DVD-Audio discs contain DVD-Video content. To play DVD-Video content, select “Play as DVD-Video” in Other Menu (→ page 22).
	Video CD VCD • Including SVCD (Conforming to IEC62107)
	DVD-RAM DVD-VR MP3 JPEG • DVD-VR Recorded with devices using Version 1.1 of the Video Recording Format (a unified video recording standard), such as DVD video recorders, DVD video cameras, personal computers, etc. • JPEG Recorded with Panasonic SD multi cameras or DVD video recorders using the DCF (Design rule for Camera File system) Standard Version 1.0.
	DVD-R (DVD-Video)^{#1}/DVD-RW (DVD-Video) DVD-V • Discs recorded and finalized ^{#2} on DVD video recorders or DVD video cameras. DVD-R (VR)^{#1}/DVD-RW (VR) DVD-VR • Discs recorded and finalized ^{#2} on DVD video recorders or DVD video cameras using Version 1.1 (or 1.2 for DVD-R DL only) of the Video Recording Format (a unified video recording standard). DVD-R/DVD-RW MP3 JPEG • Finalize ^{#2} the disc after recording.
—	+R (Video)^{#1}/+RW (Video) DVD-V • Discs recorded and finalized ^{#2} on DVD video recorders or DVD video cameras.
	CD CD WMA MP3 JPEG VCD • This unit can play CD-R/RW recorded with the above formats. Close the sessions or finalize ^{#2} the disc after recording. • CD This unit is compatible with HDCD, but does not support the Peak Extend function (a function which expands the dynamic range of high-level signals). HDCD-encoded CDs sound better because they are encoded with 20 bits, as compared with 16 bits for all other CDs. • WMA MP3 JPEG This unit also plays HighMAT discs. • WMA This unit does not support Multiple Bit Rate (MBR: a file that contains the same content encoded at several different bit rates).

^{#1} Includes single-sided, dual-layer discs.

^{#2} A process that allows play on compatible equipment.

• It may not be possible to play all the above-mentioned discs in some cases due to the type of disc or condition of the recording.

Discs that cannot be played

DVD-RW version 1.0, DVD-ROM, CD-ROM, CDV, CD-G, SACD, DivX Video Discs and Photo CD, DVD-RAM that cannot be removed from their cartridge, 2.6-GB and 5.2-GB DVD-RAM, and “Chaoji VCD” available on the market including CVD, DVCD and SVCD that do not conform to IEC62107.

Note about using a DualDisc

- The digital audio content side of a DualDisc does not meet the technical specifications of the Compact Disc Digital Audio (CD-DA) format so playback may not be possible.
- Do not use a DualDisc in this unit as it may not be possible to insert it correctly and it may get scratched or scraped.

Disc caution

To clean discs

Wipe with a damp cloth and then wipe dry.

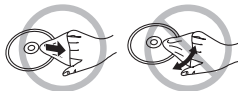

Disc handling precautions

- Do not attach labels or stickers to discs. This may cause disc warping, rendering it unusable.
- Do not write on the label side with a ball-point pen or other writing instrument.
- Do not use record cleaning sprays, benzene, thinner, liquids which prevent static electricity, or any other solvent.
- Do not use scratch-proof protectors or covers.
- Do not use the following discs:
 - Discs with exposed adhesive from removed stickers or labels (rented discs, etc.).
 - Discs that are badly warped or cracked.
 - Irregularly shaped discs, such as heart shapes.

Maintenance

Clean this unit with a soft, dry cloth.

- Never use alcohol, paint thinner or benzene to clean this unit.
- Before using chemically treated cloth, carefully read the instructions that came with the cloth.

Do not use commercially available lens cleaners as they may cause malfunction. Cleaning of the lens is generally not necessary although this depends on the operating environment.

Before moving the unit, ensure the disc trays are empty. Failure to do so will risk severely damaging the discs and the unit.



- 1. Damage requiring service**—The unit should be serviced by qualified service personnel if:
 - (a) The AC power supply cord or AC adaptor has been damaged; or
 - (b) Objects or liquids have gotten into the unit; or
 - (c) The unit has been exposed to rain; or
 - (d) The unit does not operate normally or exhibits a marked change in performance; or
 - (e) The unit has been dropped or the cabinet damaged.
- 2. Servicing**—Do not attempt to service the unit beyond that described in these operating instructions. Refer all other servicing to authorized servicing personnel.
- 3. Replacement parts**—When parts need replacing ensure the servicer uses parts specified by the manufacturer or parts that have the same characteristics as the original parts. Unauthorized substitutes may result in fire, electric shock, or other hazards.
- 4. Safety check**—After repairs or service, ask the servicer to perform safety checks to confirm that the unit is in proper working condition.

The servicer will require all components to service your system. Therefore, should service ever be necessary, be sure to bring the entire system.

Product information

For product information or assistance with product operation:

In the U.S.A., refer to “Customer Services Directory” on page 37.

In Canada, contact the Panasonic Canada Inc. Customer Care Centre at 1-800-561-5505, or visit the website (www.panasonic.ca), or an authorized Servicentre closest to you.

In other areas, consult your dealer.

Glossary

CPPM (Content Protection for Prerecorded Media)

A copy protection system used for DVD-Audio files. This unit supports CPPM.

Decoder

A decoder restores the coded audio signals on DVDs to normal. This is called decoding.

Dolby Digital

This is a method of coding digital signals developed by Dolby Laboratories. Apart from stereo (2-channel) audio, these signals can also be multi-channel audio. A large amount of audio information can be recorded on one disc using this method.

DTS (Digital Theater Systems)

This surround system is used in many movie theaters around the world. There is good separation between the channels, so realistic sound effects are possible.

Dynamic range

Dynamic range is the difference between the lowest level of sound that can be heard above the noise of the equipment and the highest level of sound before distortion occurs.

Frame still and field still

Frames are the still pictures that go together to make a moving picture. There are about 30 frames shown each second.

One frame is made up of two fields. A regular television shows these fields one after the other to create frames.

A still is shown when you pause a moving picture. A frame still is made up of two alternating fields, so the picture may appear blurred, but overall quality is high.

A field still is not blurred, but it has only half the information of a frame still so picture quality is lower.

HDMI (High-Definition Multimedia Interface)

HDMI is a next-generation digital interface for consumer electronic products. Unlike conventional connections, it transmits uncompressed digital video and audio signals on a single cable. This unit supports high-definition video output (720p, 1080i) from the HDMI AV OUT terminal. To enjoy high-definition video, a high-definition compatible television is required.

I/P/B

MPEG 2, the video compression standard adopted for use with DVD-Video, codes frames using these 3 picture types.

I: Intra coded picture

This picture has the best quality and is the best to use when adjusting the picture.

P: Predictive coded picture

This picture is calculated based on past I- or P-pictures.

B: Bidirectionally-predictive coded picture

This picture is calculated by comparing past and future I- and P-pictures so it has the lowest volume of information.

JPEG (Joint Photographic Experts Group)

This is a system used for compressing/decoding color still pictures. If you select JPEG as the storage system on digital cameras, etc., the data will be compressed to 1/10–1/100 of its original size. The benefit of JPEG is less deterioration in picture quality considering the degree of compression.

Linear PCM (pulse code modulation)

These are uncompressed digital signals, similar to those found on CDs.

MP3 (MPEG Audio Layer 3)

An audio compression method that compresses audio to approximately one tenth of its size without any considerable loss of audio quality.

Playback control (PBC)

If a Video CD has playback control, you can select scenes and information with menus.

Progressive/Interlaced

NTSC, the video signal standard, has 480 interlaced (i) scan lines, whereas progressive scanning uses twice the number of scan lines. This is called 480p.

Using progressive output, you can enjoy the high-resolution video recorded on media such as DVD-Video.

Your television must be compatible to enjoy progressive video.

Sampling frequency

Sampling is the process of converting the heights of sound wave (analog signal) samples taken at set periods into digits (digital encoding).

Sampling frequency is the number of samples taken per second, so larger numbers mean more faithful reproduction of the original sound.

WMA (Windows Media™ Audio)

WMA is a compression format developed by Microsoft Corporation. It achieves the same sound quality as MP3 with a file size that is smaller than that of MP3.

1 Power on.

POWER



2 Select "DVD/CD".

SELECTOR



- Select "AUX" (HT940) "TV" or "AUX" to enjoy video cassette recorder, television or cable TV programs. (Refer to page 9 for the necessary connections.)

3 Open the drawer and place the disc(s).

OPEN/CLOSE



- Load double-sided discs so the label for the side you want to play is facing up.
- To load discs on the other trays, press [DISC SKIP] on the main unit.
- Play will start from the disc in the front-left position of the tray.
- For DVD-RAM, remove the disc from its cartridge before use.
- Do not:
 - load more than one disc per tray.
 - touch the drawer or the carousel while they are in motion.
 - rotate the carousel by hand.
 - close the drawer by hand.



4 Close the drawer.

OPEN/CLOSE



HT940 A disc indicator lights if a disc is detected or a tray is unchecked (→ page 16, Checking the disc type in each tray).

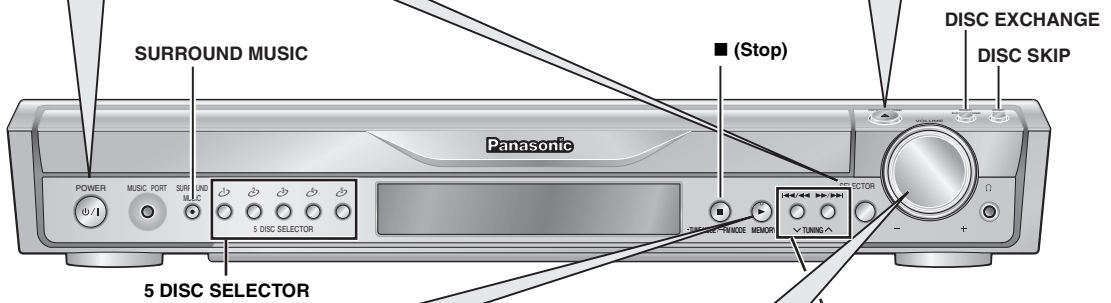

5 Start play.



When the disc finishes playing

- If the next disc does not start playing, select it with the 5 DISC SELECTOR buttons.
- You can also select the disc using the remote control (→ page 16, Checking the disc type in each tray).

To change the sound quality → page 28

6 Adjust the volume.

VOLUME



Press to skip. Press and hold to

- search during play
- start slow-motion play during pause (Motion picture part)
- Press [▶] (Play) to start normal play.



Using the main unit

Equalizing the sound

SURROUND MUSIC



- The sound fills the room, and comes from all directions with equal intensity, regardless of your orientation within the room.
- The indicator on the button lights.
- This feature is not available when using headphones or the Rear Music Port (→ page 31).

Skipping to the next disc tray

DISC SKIP



- While the drawer is closed Each time you press the button, the carousel moves counter-clockwise by one tray.

Exchanging the disc in the play position

DISC EXCHANGE



- The drawer opens and the disc in the play position comes to the front-left position.
- Press the button again to play the disc after changing the disc in the front-left position.

Changing the other discs without interrupting play

OPEN/CLOSE



Change the discs

OPEN/CLOSE



- Each time you press [DISC SKIP], you can select the other trays.

Note

- Discs continue to rotate while menus are displayed. To preserve the unit's motor and your television screen, press [■] (Stop) when you are finished with the menus.
- Total title number may not be displayed properly on +R/+RW.



Using the remote control

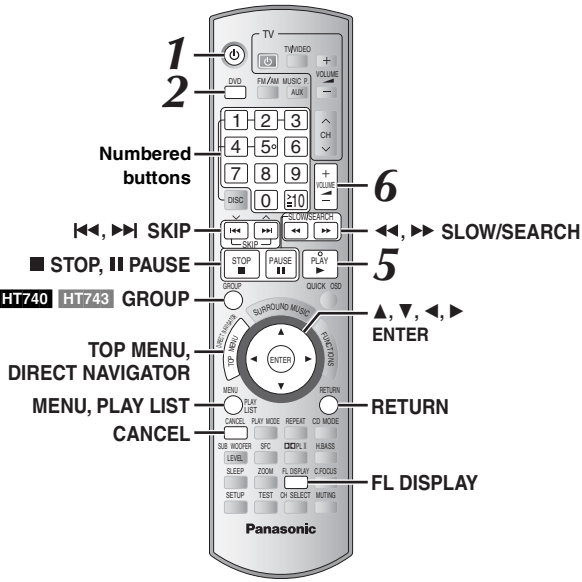

Enter number

1 2 3
4 5 6
7 8 9
0 10

DVD-VR DVD-A DVD-V VCD CD
 e.g. To select 12:
 [≧10] → [1] → [2]

VCD with playback control
 Press [■ STOP] to cancel the PBC function, and then press the numbered buttons.

WMA MP3 JPEG
 e.g. To select 123:
 [1] → [2] → [3] → [ENTER]

ENTER
 CANCEL

• Press [CANCEL] to cancel the number(s).

Disc menu

DIRECT NUMBERS
 TOP MENU

DVD-A DVD-V
 Shows a disc top menu.

DVD-VR
 Press the button to show the programs (→ page 19).

DVD-V
 Shows a disc menu.

DVD-VR
 Press the button to show a playlist (→ page 19).

MENU
 PLAY LIST

RETURN

VCD with playback control
 Shows a disc menu.

Stop

STOP

The position is memorized while "RESUME" is on the display.

- Press [▶ PLAY] to resume.
- Press [■ STOP] again to clear the position.

Pause

PAUSE

- Press [▶ PLAY] to restart play.

Skip

SKIP

ENTER

- WMA MP3 JPEG
 [This feature does not work during program and random play (→ page 17).]
- [▲, ▼]: Group skip
- [◀, ▶]: Content skip

Search (during play)

SLOW/SEARCH

- Up to 5 steps.
- Press [▶ PLAY] to start normal play.

Slow-motion (during pause)

- VCD Slow-motion: forward direction only.

Frame-by-frame (during pause)

ENTER

DVD-A (Motion picture part)
 DVD-VR DVD-V VCD

- VCD Forward direction only.

On-screen item select

Select
 Register

Return to previous screen

RETURN

—

Main unit display

FL DISPLAY

DVD-VR DVD-A DVD-V VCD CD
 WMA MP3
 Time display
 ↔ Information display (e.g. DVD-VR Program number)

JPEG
 When Slideshow (→ page 20) is on:
 SLIDE ↔ Contents number
 When Slideshow is off:
 PLAY ↔ Contents number

Starting play from a selected group

GROUP

Select
 Register

HT740 HT743
 DVD-A WMA MP3 JPEG
 A folder on WMA/MP3 and JPEG discs is treated as a "Group".

HT940
 (→ page 20, "Group" in Main menu)



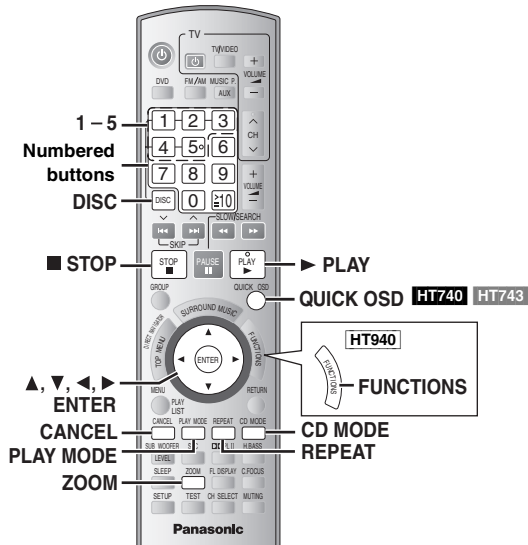

Checking the disc type in each tray

DISC

You can select the disc after checking the discs loaded with the Disc Information screen.

- You can also select the disc directly with the 5 DISC SELECTOR buttons on the main unit.

1 Press [DISC] to show the Disc information screen.

- To exit the screen, press [DISC].

e.g.

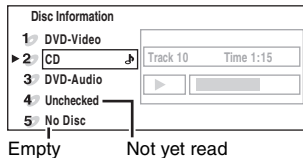

2 Press the numbered buttons ([1] - [5]) to select the disc.

Displaying current playback condition

HT740 QUICK OSD HT940
HT743 FUNCTIONS

HT740 HT743

Press [QUICK OSD].

Basics → Details
↑ off (No on-screen display) ↓

HT940

Press [FUNCTIONS].

Main menu (→ page 20) → Basics → Details
↑ off (No on-screen display) ↓

Basics

e.g. DVD-V

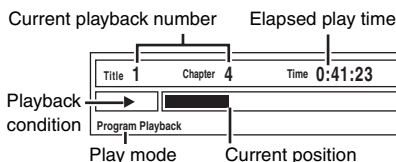

Details

e.g. DVD-V

Audio information	Details-DVD-Video	Audio	1	---	DTS 3/2.1ch
Subtitle information	Subtitle				---
Angle information	Source				1/1
Aspect of current title	Source Aspect				4:3
Total play time of current title	Title Total Time				0:54:28

Playing CDs sequentially

VCD CD WMA MP3

CD MODE

This feature is very convenient if you want to play several music CDs sequentially. Make sure that applicable disc is in the play position before playing (→ Checking the disc type in each tray, left).

While stopped

1 Press [CD MODE].



2 Press [▶ PLAY].

- If all loaded discs are DVDs or if other discs are unchecked, CD Mode does not work.
- HighMAT menus and Video CD playback control are disabled.
- You cannot turn CD Mode on or off during program or random play.
- If you want to play a DVD, press [CD MODE] again to cancel CD Mode. (CD Mode is also canceled when you switch the unit to standby, select another source, or change the disc in the play position.)
- DVD and JPEG are skipped without being played.

Changing the zoom ratio

DVD-A (Motion picture part) DVD-VR DVD-V VCD

ZOOM

This feature expands the letterbox picture to fit the screen.

During play

Press [ZOOM] several times to select the preset aspect ratio (Just Fit Zoom) or "Auto".

Auto → 4:3 Standard → European Vista → 16:9 Standard

↑ Cinemascope2 ← Cinemascope1 ← American Vista ↓

e.g.

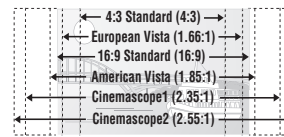
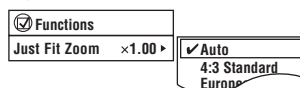

Fine adjustments (Manual Zoom)

After selecting the preset aspect ratio or "Auto", press [◀, ▶] to zoom in or out:

– in 0.01-unit steps from "×1.00" to "×1.60"

– in 0.02-unit steps from "×1.60" to "×2.00"

- To change the steps more quickly, press and hold [◀, ▶].

Repeat play

REPEAT

This works only when the elapsed play time can be displayed. It also works with all JPEG content.

During play

Press [REPEAT] several times to select an item to be repeated.

e.g. DVD-V

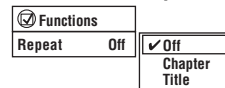

DVD-VR: Program → Disc → Off

- During playlist play: Scene → Playlist → Off

DVD-A: Track → Group* → Off

DVD-V: Chapter → Title* → Off

VCD | CD: Track → Disc* → Off

- When CD Mode is on: Track → Disc → All CD's → Off

- When CD Mode is on during program or random play: Track → All CD's → Off

WMA | MP3: Content → Group* → Off

- When CD Mode is on: Content → Group → All CD's → Off

- When CD Mode is on during program or random play: Content → All CD's → Off

JPEG: Group* → Off

*"All" is displayed during program or random play.

Program and Random play

PLAY MODE

Press [PLAY MODE] while stopped.

Program and random playback screens appear sequentially.

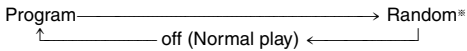

*"RANDOM 1" and "RANDOM 2" (→ right) are displayed on the main unit's display when CD Mode is on (→ page 16).

To exit the program and random mode

Press [PLAY MODE] several times while stopped.

- Selecting "Play as Data Disc" in Other Menu (→ page 22) will be effective if the following functions are not available to play WMA, MP3 or JPEG files.
- **DVD-V** Some items cannot be played even if you have programmed them.
- **DVD-A** Some discs contain bonus groups. If a password screen appears after selecting a group, enter the password with the numbered buttons to play the bonus group. Refer also to the disc's jacket.

Program play (up to 32 items)

■ When CD Mode is off

DVD-A DVD-V VCD CD WMA MP3 JPEG

You can program all the items on a disc in the play position.

① **VCD CD** Skip to step ②

Press the numbered buttons to select a group or title.

(**WMA MP3 JPEG**) Press [ENTER] to register the selection.)

e.g. **DVD-V**

T/G: Title/Group
C/T: Chapter, Content/
Track

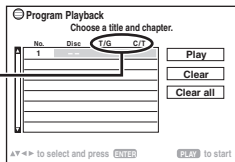

- To select a 2-digit number
e.g. To select 12: [≥10] → [1] → [2]

WMA MP3 JPEG [1] → [2] → [ENTER]

② Press the numbered buttons to select a chapter or track.

(**WMA MP3 JPEG**) Press [ENTER] to register the selection.)

- Repeat steps ① and ② to program other items.

③ Press [▶ PLAY].

■ When CD Mode is on (→ page 16)

VCD CD WMA MP3

You can program all the items on all the discs.

① Press the numbered buttons ([1] – [5]) to select a disc.

② **WMA MP3** Press the numbered buttons to select a group.

(Press [ENTER] to register the selection.)

- To select a 2-digit number
e.g. To select 12: [1] → [2] → [ENTER]

③ Press the numbered buttons to select a track.

(**WMA MP3**) Press [ENTER] to register the selection.)

- To select a 2-digit number
e.g. To select 12: [≥10] → [1] → [2]

WMA MP3 [1] → [2] → [ENTER]

- Repeat steps ① to ③ to program other items.

④ Press [▶ PLAY].

To select an item using the cursor buttons

Press [ENTER] and [▲, ▼] to select an item, and then press [ENTER] again to register.

To change the selected program

- 1 Press [▲, ▼] to select the program number.
- 2 Press the numbered buttons to change each item.
(**WMA MP3**) Press [ENTER] to register the selection.)

To clear the selected program

- 1 Press [▲, ▼] to select the program number.
- 2 Press [CANCEL] (or press [▲, ▼, ◀, ▶] to select "Clear" and press [ENTER]).

To clear the whole program

Select "Clear all" with [▲, ▼, ◀, ▶] and press [ENTER].

The whole program is also cleared when the disc is moved out of the play position, the unit is turned off or another source is selected.

Random play

■ When CD Mode is off

VCD CD

You can play all the items on a disc in the play position in random order.

DVD-A DVD-V WMA MP3 JPEG

You can play selected item(s) on a disc in the play position in random order.

① **DVD-A DVD-V WMA MP3 JPEG**

Press the numbered buttons to select a group or a title.

(**WMA MP3 JPEG**) Press [ENTER] to register the selection.)

e.g. **DVD-V**

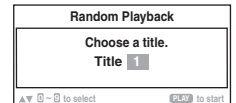

DVD-A

- To enter all groups, press [◀, ▶] to select "All" and press [ENTER].

- To deselect a group, press numbered buttons corresponding to the group you want to clear.

② Press [▶ PLAY].

■ When CD Mode is on (→ page 16)

VCD CD WMA MP3

You can select either "RANDOM 1" or "RANDOM 2".

• RANDOM 1

You can play all the items on all the discs in random order.



• RANDOM 2

You can play all the discs in sequence, but all the items on each disc are played in random order.



Press [▶ PLAY].

e.g. **CD**

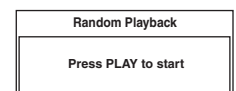

Playing data discs using navigation menus

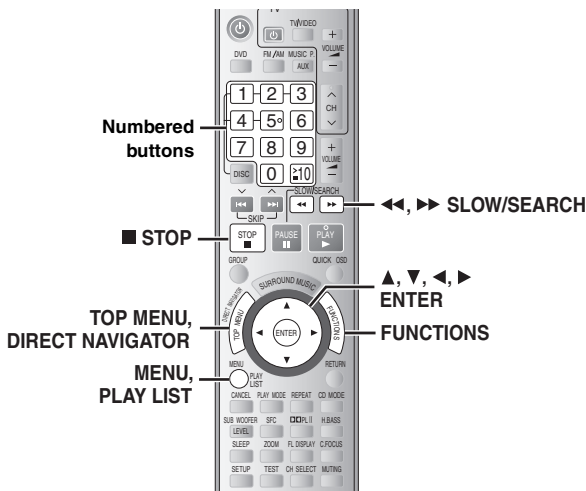

Using the submenu

- While **Navigation Menu** is displayed
Press **[FUNCTIONS]**.
- Press **[▲, ▼]** to select an item and press **[ENTER]**.
Items shown differ depending on the type of disc.

Multi	Groups and contents are displayed.
List	Contents only
Tree	Groups only
Thumbnail	Thumbnail images [JPEG]
Next group	To go to next group [WMA] [MP3]
Previous group	To go to previous group [WMA] [MP3]
All	WMA/MP3 and JPEG
Audio	WMA/MP3 only
Picture	JPEG only
Help display	To switch between guide messages and the elapsed play time indicator
Find	To search by content or group title (→ below)

Playing data discs

[WMA] [MP3] [JPEG]

Selecting "Play as Data Disc" in Other Menu (→ page 22) will be effective if the following functions are not available to play WMA, MP3 or JPEG files.

- Playing HighMAT™ discs (→ page 19)

Playing items in order (Playback Menu)

- Press **[TOP MENU]**.
• To exit the screen, press **[TOP MENU]**.

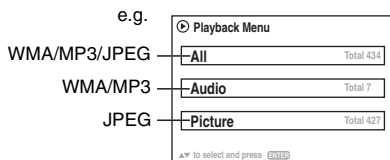

- Press **[▲, ▼]** to select "All", "Audio" or "Picture" and press **[ENTER]**.

Playing from the selected item (Navigation Menu)

- Press **[MENU]**.
• To exit the screen, press **[MENU]**.

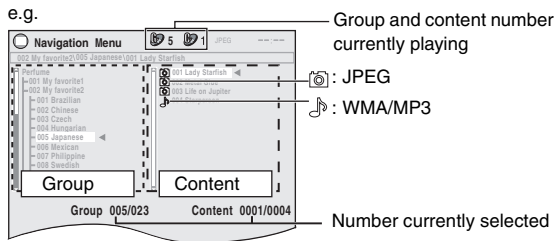

- Press **[◀]** followed by **[▲, ▼]** to select the group and press **[ENTER]**.
- To play content in the group in order
Press **[ENTER]**.
To start play from the selected content
Press **[▲, ▼]** to select and **[ENTER]**.

Searching by a content or group title

Highlight a group title to search the group, or a content title to search its content.

- While the submenu is displayed (→ above)
Press **[▲, ▼]** to select "Find" and press **[ENTER]**.



- Press **[▲, ▼]** to select a character and press **[ENTER]**.

- Repeat to enter another character.
- Lower case characters are also searched.
- Press **[◀, ▶, SLOW/SEARCH]** to skip between A, E, I, O and U.
- Press **[◀]** to erase a character.
- Leave the asterisk (*) when you search for the titles including the character you enter.
- Erase the asterisk (*) to search for the titles starting with the character you enter. To add the asterisk (*) again, display the submenu again and select "Find".

- Press **[▶]** to select "Find" and press **[ENTER]**.
The search result screen appears.

- Press **[▲, ▼]** to select the content or group and press **[ENTER]**.

Selecting a track using CD text

Titles appear with CD Text disc playback.

- Press **[TOP MENU]** or **[MENU]**.
• To exit the screen, press **[TOP MENU]** or **[MENU]**.

e.g. CD text

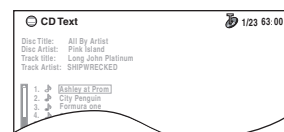

- Press **[▲, ▼]** to select the track and press **[ENTER]**.
• Press **[FUNCTIONS]** to show the playback condition and current position.

To enjoy listening to WMA/MP3 contents while showing a JPEG image on the screen, select a JPEG file first and then select audio contents. (The opposite order is not effective.)

Playing HighMAT™ discs

WMA MP3 JPEG

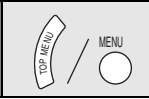

1 Press [TOP MENU].

- To exit the screen, press [STOP].
- To change the menu background to the one recorded on the disc, press [FUNCTIONS].

2 Press [▲, ▼, ◀, ▶] to select the item, and then press [ENTER].

- Repeat this step if necessary.

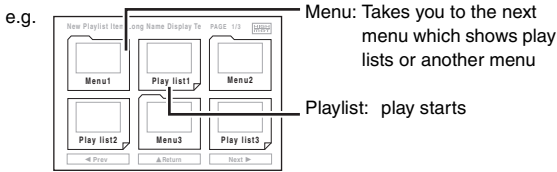

Selecting from the list

1 During play

Press [MENU].

- To exit the screen, press [MENU].



2 Press [◀] followed by [▲, ▼] to switch among "Playlist", "Group" and "Content" lists.

3 Press [▶] followed by [▲, ▼] to select an item and press [ENTER].

Playing RAM and DVD-R/-RW (DVD-VR) discs

DVD-VR



- Titles appear only if the titles are recorded on the disc.
- You cannot edit programs, playlists and disc titles.

Playing the programs

1 Press [DIRECT NAVIGATOR].

- To exit the screen, press [DIRECT NAVIGATOR].

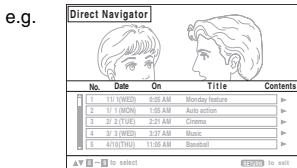

2 Press [▲, ▼] or the numbered buttons to select the program.

- To select a 2-digit number
e.g. 12: [≥10] → [1] → [2]
- Press [▶] to show the contents of the program and the disc.

3 Press [ENTER].

Playing a playlist

This works only when the disc contains a playlist.

1 Press [PLAY LIST].

- To exit the screen, press [PLAY LIST].

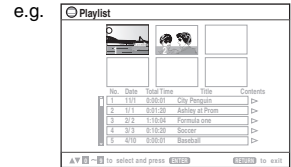

2 Press [▲, ▼] or the numbered buttons to select the playlist.

- To select a 2-digit number
e.g. 12: [≥10] → [1] → [2]

3 Press [ENTER].

■ Playing scenes one by one

- While the playlist menu is displayed
Press [▶].
- Press [▲, ▼] to select "Scene List" and press [ENTER].
• "Contents" shows playlist information.
- Press [▲, ▼, ◀, ▶] to select a scene and press [ENTER].

Tips for making data discs

- When there are more than 8 groups, the eighth group onwards will be displayed on one vertical line in the menu screen.
- There may be differences in the display order on the menu screen and computer screen.
- This unit cannot play files recorded using packet write.

DVD-RAM

- Discs must conform to UDF 2.0.

DVD-R/RW

- Discs must conform to UDF bridge (UDF 1.02/ISO9660).
- This unit does not support multi-session. Only the default session is played.

CD-R/RW

- Discs must conform to ISO9660 level 1 or 2 (except for extended formats).
- This unit supports multi-session but if there are many sessions it takes more time for play to start. Keep the number of sessions to a minimum to avoid this.

Naming folders and files

(Files are treated as contents and folders are treated as groups on this unit.)

At the time of recording, prefix folder and file names. This should be with numbers that have an equal number of digits, and should be done in the order you want to play them (this may not work at times). Files must have the extension (→ below).

WMA (Extension: ".WMA" or ".wma")

- Compatible compression rate: between 48 kbps and 320 kbps

- You cannot play WMA files that are copy-protected.
- This unit does not support Multiple Bit Rate (MBR).

MP3 (Extension: ".MP3" or ".mp3")

- Compatible compression rate: between 32 kbps and 320 kbps
- This unit does not support ID3 tags.
- Compatible sampling rates:
– DVD-RAM, DVD-R/RW: 11.02, 12, 22.05, 24, 44.1 and 48 kHz
– CD-R/RW: 8, 11.02, 12, 16, 22.05, 24, 32, 44.1 and 48 kHz

JPEG (Extension: ".JPG", ".jpg", ".JPEG" or ".jpeg")

- JPEG files taken on a digital camera that conform to DCF Standard (Design rule for Camera File system) Version 1.0 are displayed. Files that have been altered, edited or saved with computer picture editing software may not be displayed.
- This unit cannot display moving pictures, MOTION JPEG and other such formats, and still pictures other than JPEG (e.g. TIFF), or play pictures with attached audio.

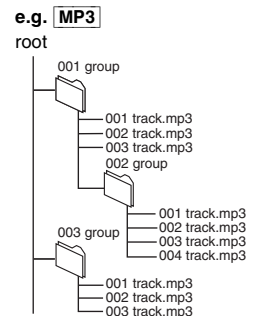

Using on-screen menus

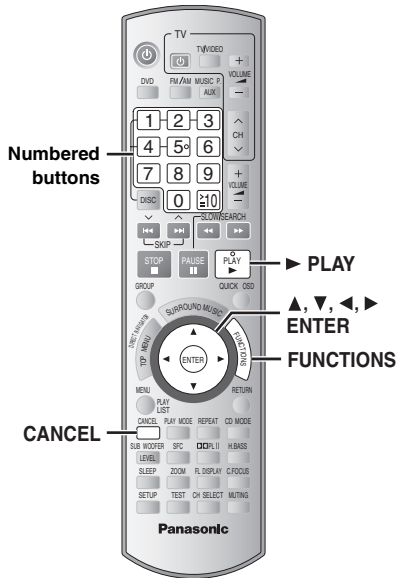

1		Show the Main menu.
2		Select the menu. e.g. DVD-V
3		Make the settings. e.g. DVD-V
4		Press to exit.

Main menu

Items shown differ depending on the type of disc.

Program Group Title Chapter Track Playlist Content	<p>To start from a specific item e.g. DVD-VR To select Program 12 Press the numbered buttons: [1] → [2] → [ENTER]</p>
Time	<p>(Time Slip and Time Search do not work with +R/+RW discs.) To skip incrementally or decrementally (Time Slip for play only) 1 Press [ENTER] twice to show the Time Slip indicator. 2 Press [▲, ▼] to select the time and press [ENTER]. • To change the steps more quickly, press and hold [▲, ▼].</p> <p>To start from a specific time (Time Search) To change remaining/elapsed time display</p>
Audio	<p>DVD-A DVD-V (with multiple soundtracks) To select audio soundtrack DVD-VR VCD To select "L", "R" or "LR" DVD-V (Karaoke disc) To select "On" or "Off" for vocals • Read the disc's instructions for details.</p> <p>Signal type/data LPCM/PPCM/Digital/DTS/MP3/MPEG: Signal type kHz (Sampling frequency)/bit/ch (Number of channels) e.g. 3/2 1ch</p> <ul style="list-style-type: none"> .1: Low frequency effect (not displayed if there is no signal) 0: No surround 1: Mono surround 2: Stereo surround (left/right) 1: Center 2: Front left+Front right 3: Front left+Front right+Center <p>WMA MP3 To display the current bitrate or sampling frequency</p>

Still Picture	To switch still pictures
Thumbnail	To show thumbnail images
Subtitle	<p>DVD-V (with multiple subtitles) VCD (SVCD only) To select subtitle language • On +R/+RW, a subtitle number may be shown for subtitles that are not displayed. • DVD-VR "On" or "Off" appears only with discs that contain subtitle on/off information (Subtitle on/off information cannot be recorded using Panasonic DVD Recorders).</p>
Marker (VR)	<p>DVD-VR To recall a marker recorded on DVD-Video recorders Press [▲, ▼] → Press [ENTER].</p>
Angle	(with multiple angles) To select a video angle
Rotate Picture	To rotate a picture
Slideshow	<p>To turn on/off slideshow On ↔ Off To change the slideshow timing 1 (Fast) to 5 (Slow)</p>
Other Settings	(→ page 21)

Play Speed	DVD-A (Motion picture part) DVD-VR DVD-V
	<p>To change play speed – from “×0.6” to “×1.4”</p> <ul style="list-style-type: none"> ● Press [▶] PLAY] to return to normal play. ● After you change the speed <ul style="list-style-type: none"> – Dolby Pro Logic II and Sound Enhancement have no effect. – Audio output switches to 2-channel stereo (except when Surround Music is on). – Sampling frequency of 96 kHz is converted to 48 kHz. ● This function may not work depending on the disc’s recording.

■ Play Menu

This works only when the elapsed play time can be displayed. It also works with all JPEG content.

Repeat	(→ page 16, Repeat play)
A-B Repeat	<p>Except JPEG DVD-VR (Still picture part)</p> <p>To repeat a specified section Press [ENTER] at the starting and ending points. Press [ENTER] again to cancel.</p>
Marker	<p>Except DVD-VR</p> <p>To mark up to 5 positions to play again Press [ENTER] (The unit is now ready to accept markers.)</p> <p>To mark a position: Press [ENTER] (at the desired point).</p> <p>To mark another position: Press [◀, ▶] to select “*” → Press [ENTER].</p> <p>To recall a marker: Press [◀, ▶] → Press [ENTER].</p> <p>To erase a marker: Press [◀, ▶] → Press [CANCEL].</p> <ul style="list-style-type: none"> ● This feature does not work during program and random play. ● Markers you add are cleared when you change the disc in the play position or switch the unit to standby.
Advanced Disc Review	<p>DVD-VR (Except still picture part)</p> <p>DVD-V (Except +R/+RW)</p> <p>Allows you to browse the disc contents and start playing from the selected position. You can select either “Intro Mode” or “Interval Mode” in “Advanced Disc Review” in the “Disc” tab (→ page 23).</p> <p>When you find a title/program to play Press [▶] PLAY].</p> <ul style="list-style-type: none"> ● This may not work depending on the disc and the play position. ● DVD-VR This does not work when playing a playlist (→ page 19).

■ Picture Menu

Picture Mode	<p>Normal</p> <p>Cinema1: Mellows images and enhances detail in dark scenes.</p> <p>Cinema2: Sharpens images and enhances detail in dark scenes.</p> <p>Animation: Suitable for animation.</p> <p>Dynamic: Enhances the contrast for powerful images.</p> <p>User: Press [ENTER] to select “Picture Adjustment” (→ below).</p>
	<p>Picture Adjustment</p> <p>Contrast: Increases the contrast between light and dark parts of the picture.</p> <p>Brightness: Brightens the picture.</p> <p>Sharpness: Adjusts the sharpness of the edges of horizontal lines.</p> <p>Color: Adjusts the shade of the picture’s color.</p> <p>Gamma: Adjusts the brightness of dark parts.</p> <p>Depth Enhancer: Reduces the rough noise in the background to give a greater feeling of depth.</p>
Video Output Mode	<p>To select suitable picture quality with your television (Video recordings will be converted to, and output as, high-definition video.)</p> <p>When HDMI connection is being used and “Video Output” (→ page 24, “HDMI” tab) is set to “On”</p> <p>480p (progressive) 720p (progressive) 1080i (interlaced)</p> <ul style="list-style-type: none"> ● Select a video output with an “*” mark. The “*” mark shows that the video output is acceptable with your television. ● Selecting a video output without an “*” mark can result in the picture being distorted. If the picture is distorted, press and hold [CANCEL] until the picture is displayed correctly. (The output will return to “480p”.) ● Output from the COMPONENT VIDEO OUT terminals will be “480p”.
	<p>When HDMI connection is not being used and “Video Output” (→ page 24, “HDMI” tab) is set to “Off”</p> <p>480i (interlaced) 480p (progressive)</p> <ul style="list-style-type: none"> ● When you select “480p”, a confirmation screen appears. Select “Yes” only if connecting to a progressive output compatible television.
Transfer Mode	<p>If you have chosen “480p”, “720p” or “1080i” (→ above), select the method of conversion for progressive output to suit the type of material.</p> <p>Auto1: Detects 24 frame-per-second film content and appropriately converts it.</p> <p>Auto2: Compatible with 30 frame-per-second film content in addition to 24 frame-per-second film content.</p> <p>Video: Select when using Auto1 or Auto2, and the video content is distorted.</p>

(Continued on next page)



Other Settings

Items shown differ depending on the type of disc.

Picture Menu (Continued)

HD Picture Enhancer	This works when the HDMI connection is being used and "Video Output" (→ page 24, "HDMI" tab) is set to "On". To sharpen the "720p" and "1080i" picture quality Off ← 1 ← 2 ← 3 (sharpest picture) ↑
HDMI Color Space	This works when the HDMI connection is being used and "Video Output" (→ page 24, "HDMI" tab) is set to "On". To select suitable picture color with your television RGB YCbCr (4:4:4) YCbCr (4:2:2) <ul style="list-style-type: none">• If the setting above is not compatible with your television, it will not be displayed.• "RGB Range" (→ page 24, "HDMI" tab) is available when "RGB" is selected.

Audio Menu

Dolby Pro Logic II	(→ page 28, Enhancing the stereo sound: Dolby Pro Logic II)
Dialogue Enhancer	To make the dialogue in movies easier to hear [DVD-V] (Dolby Digital, DTS, 3-channel or higher, with the dialogue recorded in the center channel) On ← Off
Sound Enhancement	To enjoy comfortable, analog-like sound [DVD-VR] [DVD-V] (Discs recorded with 48 kHz only) [WMA] [MP3] (Disc recording is other than 8 kHz, 16 kHz or 32 kHz) [VCD] [CD] On ← Off <ul style="list-style-type: none">• This may have no effect depending on the disc's recording.• This does not work with MP3 on DVD-RAM or DVD-R/RW.

Display Menu

Information	[JPEG] On ← Off
Subtitle Position	0 to -60 (in 2 unit steps)
Subtitle Brightness	Auto, 0 to -7
4:3 Aspect	To select how to show images made for 4:3 aspect screens on a 16:9 aspect television Normal: Laterally stretches images. Auto: Expands 4:3 letterbox images to fill more of the screen. Other images appear in full in the center of the screen. Shrink: Images appear in the center of the screen. Zoom: Expands to 4:3 aspect ratio. If your television has a similar feature, use it instead for a better effect.
Just Fit Zoom	To select the appropriate screen size to fit your television screen (Also refer to "Changing the zoom ratio" on page 16.)
Manual Zoom	To zoom in and out manually (Also refer to "Changing the zoom ratio" on page 16.)
Bit Rate Display	[DVD-VR] [DVD-V] [VCD] [DVD-A] (Motion picture part) On ← Off
GUI See-through	To make the on-screen menu transparent Off, On, Auto
GUI Brightness	To adjust the on-screen menu brightness -3 to +3
HDMI Status	Indicates various information when connected with HDMI AV OUT terminal. (→ below, Confirming HDMI information)
[HT740] [HT743] Quick OSD	To display current playback condition Off, Basics, Details After registering the item, press [RETURN] to show the QUICK OSD screen (→ page 16).

Other Menu

Setup	(→ page 23)
Play as DVD-Video or Play as DVD-Audio	To play DVD-Video contents of DVD-Audio Select "Play as DVD-Video".
Play as DVD-VR, Play as HighMAT or Play as Data Disc	To use functions for data discs (→ page 18) (To play JPEG or MP3 files on DVD-RAM, or to play a HighMAT disc without using the HighMAT function) Select "Play as Data Disc".

Confirming HDMI information

■ HDMI Status—HDMI is connected.	Connection status
HDMI Information	
Audio Stream <u>PCM</u>	Shows the output signal type.
Max Channel <u>2ch</u>	Shows the number of audio channels.
Video Format <u>480p/720p/1080i</u>	(→ page 21, Video Output Mode)
Color Space <u>YCbCr (4:4:4)/YCbCr (4:2:2)/RGB</u>	(→ above, HDMI Color Space)

Note

- All possible types of output are displayed.
- The current output for "Audio Stream", "Video Format" and "Color Space" will be underlined.
(If you select a video output without an "*" mark in the "Video Output Mode" in Picture Menu, the selected video format will not be underlined.)
- When "Off" is selected in "Audio Output" (→ page 24, "HDMI" tab), "--" will be displayed in "Audio Stream" and "Max Channel".

Changing the player settings

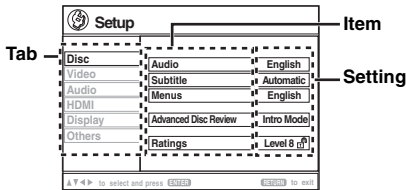
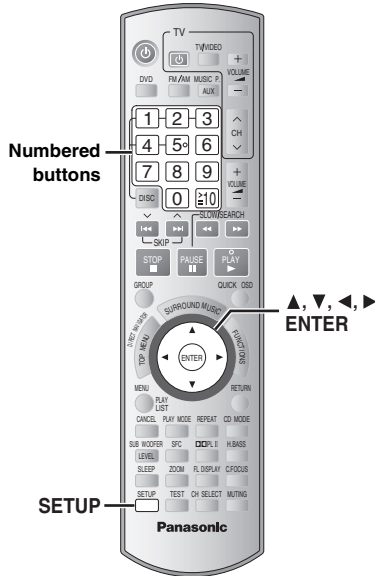

- The settings remain intact even if you switch the unit to standby.
- Underlined items are the factory settings in the following diagram.

1		<p>Show the Setup menu. If you have not performed QUICK SETUP (→ page 11), the QUICK SETUP screen appears.</p>
2		<p>Select the tab.</p>
3		<p>Select the item.</p>
4		<p>Make the settings.</p>
5		<p>Press to exit.</p>

QUICK SETUP enables successive settings of the items in the shaded area.

■ “Disc” tab

<p>Audio Choose the audio language.</p>	<p>• <u>English</u> • French • Spanish • Original*^{#1} • Other** * * * *^{#2}</p>
<p>Subtitle Choose the subtitle language.</p>	<p>• <u>Automatic</u>^{#3} • English • French • Spanish • Other** * * * *^{#2}</p>
<p>Menus Choose the language for disc menus. Changing the menu language in QUICK SETUP also changes this setting.</p>	<p>• <u>English</u> • French • Spanish • Other** * * * *^{#2}</p>
<p>Advanced Disc Review (→ page 21)</p>	<p>• Intro Mode: Reviews each title/program. • Interval Mode: Reviews not only each title/program but also each 10-minute interval within a title/program.</p>
<p>Ratings Set a rating level to limit DVD-Video play.</p>	<p>Setting ratings (When level 8 is selected) • <u>8 No Limit</u> • 1 to 7 • 0 Lock All: To prevent play of discs without rating levels.</p> <p>When you select your ratings level, a password screen is shown. Follow the on-screen instructions. Do not forget your password. A message screen will be shown if a DVD-Video disc exceeding the rating level is inserted in the unit. Enter your password and then follow the on-screen instructions.</p>



^{#1} The original language designated on the disc is selected.
^{#2} Input the appropriate code from the language code list (→ page 25).
^{#3} If the language selected for “Audio” is not available, subtitles appear in that language (if available on the disc).

(Continued on next page)

Changing the player settings

QUICK SETUP enables successive settings of the items in the shaded area.

■ “Video” tab

TV Aspect Choose the setting to suit your television and preference.	<ul style="list-style-type: none"> ● 4:3 Pan&Scan: Regular aspect television (4:3) The sides of the widescreen picture are cut off so it fills the screen (unless prohibited by the disc). 
	<ul style="list-style-type: none"> ● 4:3 Letterbox: Regular aspect television (4:3) Widescreen picture is shown in the letterbox style. 
	<ul style="list-style-type: none"> ● 16:9: Widescreen television (16:9)
TV Type Select to suit the type of television.	<ul style="list-style-type: none"> ● Standard (Direct View TV) ● Projection TV ● CRT Projector ● Plasma TV ● LCD TV/Projector
Time Delay When connected with a Plasma display, adjust if you notice the audio is out of sync with the video.	<ul style="list-style-type: none"> ● 0ms ● 20ms ● 40ms ● 60ms ● 80ms ● 100ms
Still Mode Specify the type of picture shown when paused.	<ul style="list-style-type: none"> ● Automatic ● Field*: The picture is not blurred, but picture quality is lower. ● Frame*: Overall quality is high, but the picture may appear blurred.
Black Level Control Change the black level of the picture if you connected a television through the COMPONENT VIDEO OUT terminals.	<ul style="list-style-type: none"> ● Lighter: When connected through VIDEO OUT or S-VIDEO OUT. ● Darker: When connected through COMPONENT VIDEO OUT (Y/P_B/P_R).

*Refer to “Frame still and field still” (→ page 13, Glossary).

■ “Audio” tab

Dynamic Range Compression	<ul style="list-style-type: none"> ● Off ● On: Adjusts for clarity even when the volume is low by compressing the range of the lowest sound level and the highest sound level. Convenient for late night viewing. (Only works with Dolby Digital)
Speaker Settings (→ page 25) Set the delay time for your center and surround speakers.	<ul style="list-style-type: none"> ● Center: 0.0/1.0/2.0/3.0/4.0/5.0 ms ● Surround (L/R): 0.0/5.0/10.0/15.0 ms

■ “HDMI” tab

RGB Range Set “HDMI Color Space” to “RGB” (→ page 22, Picture Menu).	<ul style="list-style-type: none"> ● Standard ● Enhanced: When the black and white images are not distinct.
Video Output (This setting is irrelevant when connected through the VIDEO OUT or S-VIDEO OUT terminal.)	<ul style="list-style-type: none"> ● On: When connected through the HDMI AV OUT terminal. Video is output from the HDMI terminal. Video is also output from the COMPONENT VIDEO OUT terminal, but only in 480p (progressive). ● Off: When connected through the COMPONENT VIDEO OUT terminal. Video is not output from the HDMI AV OUT terminal, but from the COMPONENT VIDEO OUT terminal according to the setting of the “Video Output Mode” (→ page 21, Picture Menu).
Audio Output	<ul style="list-style-type: none"> ● On: When audio output is from the HDMI AV OUT terminal. (Depending on the capabilities of the connected equipment, audio output may differ from the audio settings of the main unit.) ● Off: When audio output is not from the HDMI AV OUT terminal. (The audio is output using the settings of the main unit.)
[HT940] Control with HDMI (HDAVI Control)	<ul style="list-style-type: none"> ● On: The HDAVI Control function is available (→ page 30). ● Off

■ “Display” tab

Menu Language	<ul style="list-style-type: none"> ● English ● Français ● Español
On-Screen Messages	<ul style="list-style-type: none"> ● On ● Off

■ “Others” tab

FL Dimmer Change the brightness of the unit’s display and Jog LED.	<ul style="list-style-type: none"> ● Bright ● Dim (Jog LED turns off.) ● Auto: The display is dimmed, but brightens when you perform some operations. (Jog LED turns on when you perform some operations.)
QUICK SETUP	<ul style="list-style-type: none"> ● Yes ● No
Re-initialize Setting Return all values in the Setup menus to the default settings.	<ul style="list-style-type: none"> ● Yes: The password screen is shown if “Ratings” (→ page 23) is set. Please enter the same password. After “INIT” on the display disappears, turn the unit off and on again. ● No



Changing the delay time of the speakers

(Effective when playing multi-channel audio)

(Center and surround speakers only)

For optimum listening with 5.1-channel sound, all the speakers, except for the subwoofer, should be the same distance from the seating position.

If you have to place the center or surround speakers closer to the seating position, adjust the delay time to make up for the difference.

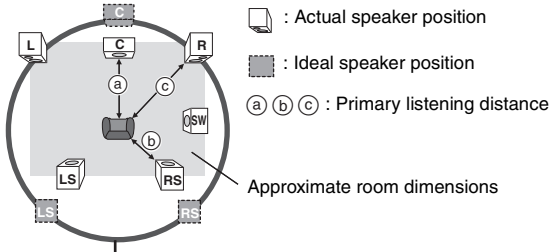

Circle of constant primary listening distance

If either distance **a** or **b** is less than **c**, find the difference in the table and change to the recommended setting.

a Center speaker		b Surround speaker	
Difference (Approx.)	Setting	Difference (Approx.)	Setting
30 cm (1 foot)	1.0 ms	150 cm (5 feet)	5.0 ms
60 cm (2 feet)	2.0 ms	300 cm (10 feet)	10.0 ms
90 cm (3 feet)	3.0 ms	450 cm (15 feet)	15.0 ms
120 cm (4 feet)	4.0 ms		
150 cm (5 feet)	5.0 ms		

- 1 Press **[▲, ▼]** to select the delay time box and press **[ENTER]**.
- 2 Press **[▲, ▼]** to adjust the delay time and press **[ENTER]**.

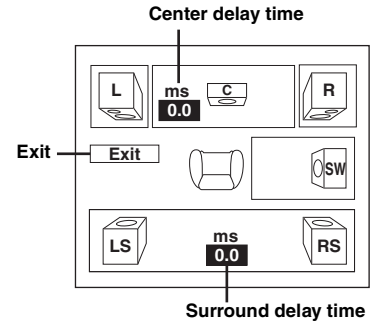

To finish the speaker setting

Press **[◀]** to select "Exit" and press **[ENTER]**.

When you change the surround speaker setting for Dolby Digital, the setting also changes for Dolby Pro Logic II.

e.g., the settings for Music are the same as those for Dolby Digital.

Dolby Digital	Dolby Pro Logic II	
	Music	Movie
0 ms	0 ms	10 ms
5 ms	5 ms	15 ms
10 ms	10 ms	20 ms
15 ms	15 ms	25 ms

Language code list

Abkhazian: 6566	Danish: 6865	Italian: 7384	Norwegian: 7879	Swedish: 8386
Afar: 6565	Dutch: 7876	Japanese: 7465	Oriya: 7982	Tagalog: 8476
Afrikaans: 6570	English: 6978	Javanese: 7487	Pashto, Pushto: 8083	Tajik: 8471
Albanian: 8381	Esperanto: 6979	Kannada: 7578	Persian: 7065	Tamil: 8465
Ameharic: 6577	Estonian: 6984	Kashmiri: 7583	Polish: 8076	Tatar: 8484
Arabic: 6582	Faroese: 7079	Kazakh: 7575	Portuguese: 8084	Telugu: 8469
Armenian: 7289	Fiji: 7074	Kirghiz: 7589	Punjabi: 8065	Thai: 8472
Assamese: 6583	Finnish: 7073	Korean: 7579	Quechua: 8185	Tibetan: 6679
Aymara: 6589	French: 7082	Kurdish: 7585	Rhaeto-Romance: 8277	Tigrinya: 8473
Azerbaijani: 6590	Frisian: 7089	Laotian: 7679	Romanian: 8279	Tonga: 8479
Bashkir: 6665	Galician: 7176	Latin: 7665	Russian: 8285	Turkish: 8482
Basque: 6985	Georgian: 7565	Latvian, Lettish: 7686	Samoan: 8377	Turkmen: 8475
Bengali, Bangla: 6678	German: 6869	Lingala: 7678	Sanskrit: 8365	Twi: 8487
Bhutani: 6890	Greek: 6976	Lithuanian: 7684	Scots Gaelic: 7168	Ukrainian: 8575
Bihari: 6672	Greenlandic: 7576	Macedonian: 7775	Serbian: 8382	Urdu: 8582
Breton: 6682	Guarani: 7178	Malagasy: 7771	Serbo-Croatian: 8372	Uzbek: 8590
Bulgarian: 6671	Gujarati: 7185	Malay: 7783	Shona: 8378	Vietnamese: 8673
Burmese: 7789	Hausa: 7265	Malayalam: 7776	Sindhi: 8368	Volapük: 8679
Byelorussian: 6669	Hebrew: 7387	Maltese: 7784	Singhalese: 8373	Welsh: 6789
Cambodian: 7577	Hindi: 7273	Maori: 7773	Slovak: 8375	Wolof: 8779
Catalan: 6765	Hungarian: 7285	Marathi: 7782	Slovenian: 8376	Xhosa: 8872
Chinese: 9072	Icelandic: 7383	Moldavian: 7779	Somali: 8379	Yiddish: 7473
Corsican: 6779	Indonesian: 7378	Mongolian: 7778	Spanish: 6983	Yoruba: 8979
Croatian: 7282	Interlingua: 7365	Nauru: 7865	Sundanese: 8385	Zulu: 9085
Czech: 6783	Irish: 7165	Nepali: 7869	Swahili: 8387	

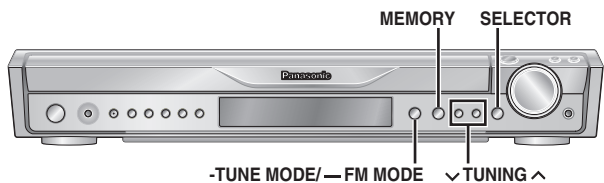
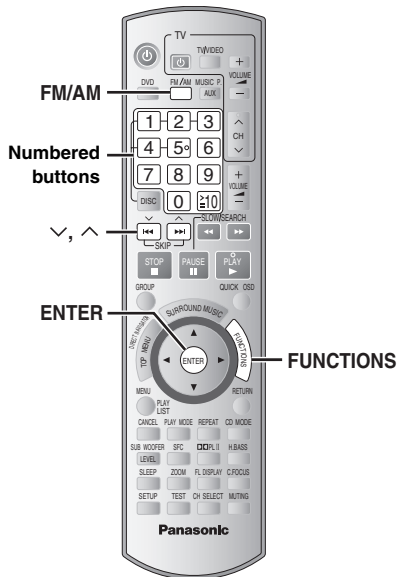

Selecting the preset channels

- 1 Press [FM/AM] to select "FM" or "AM".
- 2 Press the numbered buttons to select the channel.
 - To select a 2-digit number
e.g. 12: [≥ 10] → [1] → [2]
 Alternatively, press [\vee , \wedge].

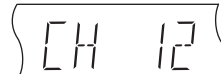

When a stereo FM broadcast is being received, "ST" lights in the display.

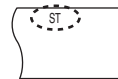

■ If noise is excessive

When "FM" is selected

Press and hold [—FM MODE] on the main unit to display "MONO".



Press and hold [—FM MODE] again to cancel the mode.

- The mode is also canceled when you change the frequency.

When "AM" is selected

Press [FUNCTIONS] on the remote control.
Each time you press the button: BP 2 ↔ BP 1

Manual tuning

Main unit only

- 1 Press [SELECTOR] to select "FM" or "AM".
- 2 Press [-TUNE MODE] to select "MANUAL".
- 3 Press [\vee TUNING \wedge] to select the frequency.
 - To start automatic tuning, press and hold [\vee TUNING \wedge] until the frequency starts scrolling. Tuning stops when a station is found.

■ Presetting the channel

Up to 15 stations can be set in each band, FM and AM.

- ① While listening to the radio broadcast
Press [ENTER].
- ② While the frequency and "PGM" are flashing on the display
Press the numbered buttons to select a channel.
 - To select a 2-digit number
e.g. To select 12:
[≥ 10] → [1] → [2]
 Alternatively, press [\vee , \wedge], and then press [ENTER].

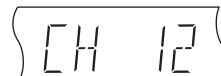

The station occupying a channel is erased if another station is preset to that channel.

Presetting stations automatically

Main unit only

Up to 15 stations can be set in each band, FM and AM.

- 1 Press [SELECTOR] to select "FM" or "AM".
- 2 Press [-TUNE MODE] to select "MANUAL".
Each time you press the button: MANUAL ↔ PRESET
- 3 Press [\vee TUNING \wedge] to tune to the lowest frequency (FM: 87.9 or 87.5, AM: 520).
- 4 Press and hold [MEMORY].
Release the button when "FM AUTO" or "AM AUTO" is displayed.

The tuner presets all the stations it can receive into the channels in ascending order.

- "SET OK" is displayed when the stations are set, and the radio tunes to the last preset station.
- "ERROR" is displayed when automatic presetting is unsuccessful. Preset the channels manually (→ right).

■ FM frequency step

Main unit only

The step is factory-set to 0.2-MHz, but you can change it to receive broadcasts allocated in 0.1-MHz steps.

- ① Press **[SELECTOR]** to select "FM".
- ② Press and hold **[SELECTOR]**.
After a few seconds the display changes to show the current minimum frequency. Continue to hold the button down. The minimum frequency changes and the step is changed.

To return to the original step, repeat steps ① and ②.

Note

After changing the setting, previously preset frequencies will be cleared. Preset them again.

Using an outdoor antenna (optional)

Use outdoor antennas if radio reception is poor.

- Disconnect the antenna when the unit is not in use.
- Do not use the outdoor antenna during an electrical storm.

The illustration shows SC-HT740 for U.S.A. and Canada.

FM outdoor antenna (Using a television antenna)

- Disconnect the FM indoor antenna.
- The antenna should be installed by a competent technician. Rework your outdoor antenna's 75 Ω coaxial cable as follows.

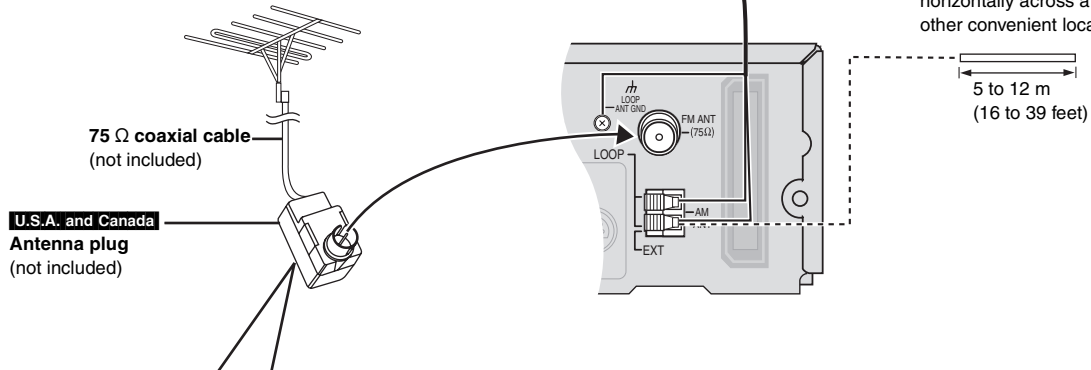

Leave the AM loop antenna connected.

AM outdoor antenna (Using a vinyl wire)

Run a piece of vinyl wire horizontally across a window or other convenient location.

5 to 12 m
(16 to 39 feet)

- ① Remove a piece of the outer vinyl insulator.

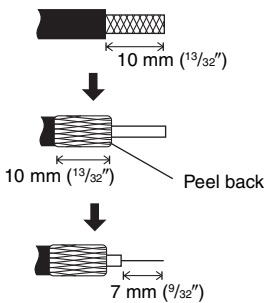

- ② Carefully pull the tabs apart to remove the cover.

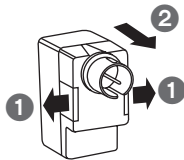

- ③ Install the coaxial cable. Clamp the cable conductor, and wind it on so that it does not contact anything else.

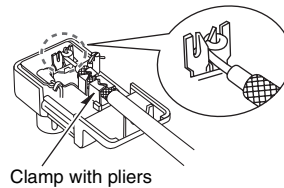

- ④ Attach the cover.



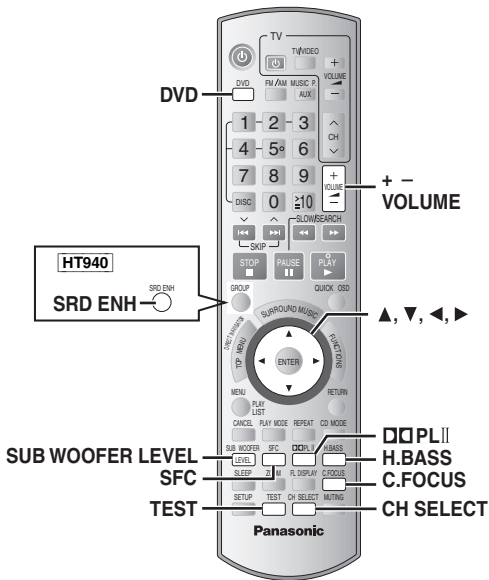

Enhancing the sound from the center speaker: Center Focus

C.FOCUS



This applies to discs where the dialogue is recorded in the center channel.

You can make the sound of the center speaker seem like it is coming from within the television.

Press [C.FOCUS].

Each time you press the button:
C FOCUS ON \longleftrightarrow C FOCUS OFF



- This does not work when Surround Music (→ page 14) or Sound Field Control (MOVIE, SPORT or MUSIC) is turned on.
- This also works when Dolby Pro Logic II is turned on.

Enhancing the stereo sound: Dolby Pro Logic II

DOLBY II



Dolby Pro Logic II is an advanced decoder that derives 5-channel surround (Left and Right Front, Center, Left and Right Surround) from stereo sound sources, whether or not it has been specifically Dolby Surround encoded.

Press [DOLBY II].

Each time you press the button:

- Movie:** Movie software, recorded in Dolby Surround.
- Music:** Stereo sources
- Off:** Cancel



- This works only in DVD/CD mode.
- "DOLBY II" lights when there is effect.
- This does not work when audio is output from HDMI AV OUT terminal.
- Dolby Pro Logic II is canceled when Surround Music is turned on.

Changing the sound quality: Sound Field Control

SFC



To enjoy the following sound quality settings, ensure that Surround Music (→ page 14) is turned off.

Press [SFC].

Each time you press the button:

- FLAT:** Cancel (no effect is added) (factory preset).
- MOVIE:** Use this mode when playing movie software.
- SPORT:** Simulates sound to make you feel like you are at a sports event.
- MUSIC:** Adds surround effects to stereo sources.
- HEAVY:** Adds punch to rock.
- CLEAR:** Clarifies higher sounds.
- SOFT:** For background music.

- To check the current setting, press [SFC].
- MOVIE, SPORT and MUSIC are not available when Dolby Pro Logic II is on, or when play a disc recorded with a multi-channel source.
- You can adjust the volume of the surround speakers to get the best surround effect (→ page 29, Speaker level adjustments).

HT940 Enhancing the surround sound effect: Surround Enhancer

SRD ENH



Press [SRD ENH].

Each time you press the button:
SRD ENH ON \longleftrightarrow SRD ENH OFF



Surround Enhancer will be canceled when Surround Music (→ page 14) is turned on and vice versa.

Enhancing the bass sound: H.BASS

H.BASS



You can enhance low-frequency sound so that heavy bass sound can be heard clearly, even if the acoustics of your room are not optimal. The unit automatically selects the most suitable setting according to the type of playback source.

Press [H.BASS].



● **DVD-V** **DVD-VR**

H.BASS ON (factory preset) ← → H.BASS OFF

● **When another source is selected**

H.BASS OFF (factory preset) ← → H.BASS ON

The setting you make is retained, and recalled every time you play from the same type of source.

Adjusting the amount of bass: Subwoofer level

SUB WOOFER

LEVEL

You can adjust the amount of bass. The unit automatically selects the most suitable setting according to the type of playback source.

Press [SUB WOOFER LEVEL].

● **DVD-V** **DVD-VR**

SUB W 4 (factory preset)* → SUB W 1 → SUB W 2 → SUB W 3



● **When another source is selected**

SUB W 2 (factory preset)* → SUB W 3 → SUB W 4 → SUB W 1



● To check the current setting, press [SUB WOOFER LEVEL].

● The setting you make is retained, and recalled every time you play the same type of source, except when Sound Field Control (MOVIE, SPORT or MUSIC) is turned on.

* When Sound Field Control (MOVIE, SPORT or MUSIC) is on, the factory presets are as follows:

- MOVIE: SUB W 4
- SPORT: SUB W 2
- MUSIC: SUB W 1

Adjusting the volume of each speaker: Speaker level adjustments

TEST



This is one of the ways to get appropriate surround effects.

Preparation

Press [DVD].

1 While stopped and no on-screen display is shown
Press [TEST] to output a test signal.

- To stop the test signal, press [TEST] again.

L: Front left C: Center R: Front right
RS: Right surround LS: Left surround

- There is no output from SW (subwoofer) channel.

2 Press [VOLUME, +] or [–] to set the volume level normally used for listening.

3 Press [▲] (increase) or [▼] (decrease) to adjust the speaker level for each speaker.

- Adjust the speaker levels to the same level as the front speakers.

C, RS, LS: –6 dB to +6 dB

■ To adjust speaker level during play

(Effective when playing multi-channel audio or when Dolby Pro Logic II or Sound Field Control (MOVIE, SPORT or MUSIC) is on, and Surround Music is off.)

① Press [CH SELECT] to select the speaker.

L → C → R → RS → LS → SW



SW: Subwoofer

- You can adjust SW only if the disc includes a subwoofer channel.
- "SW" does not appear on the display and is not adjustable when "DOLBY II" is lit.
- "S" appears on the display when "MOVIE", "SPORT" or "MUSIC" is selected with Sound Field Control (→ page 28). In this case, you can adjust both surround speaker levels at the same time using [▲, ▼].

S: –6 dB to +6 dB

② Press [▲] (increase) or [▼] (decrease) to adjust the speaker level for each speaker.

C, RS, LS, SW: –6 dB to +6 dB

(L, R: Only the balance is adjustable.)

- To adjust the balance of the front speakers, while "L" or "R" is selected, press [◀, ▶].



Operating other equipment

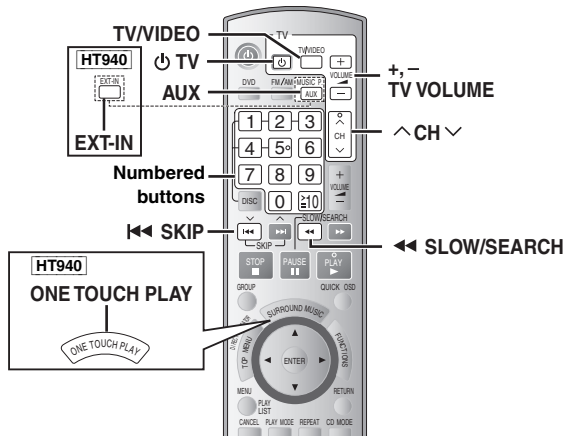

HT940 Operating both the television and the home theater system: Control with HDMI (HDAVI Control™)

What is HDAVI Control?
HDAVI Control is a convenient function that offers linked operation of this unit and Panasonic TV (VIERA) with HDAVI Control. You can use this function by connecting the equipment with the HDMI cable. For operational details, see the operating instructions of the connected equipment.

- Preparation**
- Confirm that the HDMI connection (→ page 8) has been made.
 - Set “Control with HDMI” (HDAVI control) to “On” (→ page 24, “HDMI” tab).
 - To complete and activate the connection correctly, turn on all HDAVI Control compatible equipment and select the input channel corresponding to the home theater on the television.

Whenever the connection or settings are changed, reconfirm the points above.

Operating the television

You can use the remote control to operate a Panasonic television. Connect your equipment referring to “Cable TV box or video cassette recorder connection” (→ page 9).

Note
The remote control may not work properly with some models.

Aim the remote control at the television.

Turning the television on/off

Press [TV].

Switching the television’s video input mode

Press [TV/VIDEO].

Changing channels

Press [^ CH v].

- [≥10] is used to confirm channel selection on some televisions manufactured by other companies.

Adjusting the volume

Press [+ , - TV VOLUME].

To play audio from your television through your home theater system

Press [AUX] ([HT940] [EXT-IN]) to select “AUX” ([HT940] “TV” or “AUX”) as the source, reduce the volume on the television to its minimum, and control the volume on the main unit.

Changing the remote control code

This remote control can also operate some other brands of televisions. You can change the code to operate your television (→ below).

Aim the remote control at the television.

While pressing [TV]

Press the numbered buttons to enter the 4-digit code.

The remote control outputs the on/off signal. If the code is correct, the television turns on or off. If it does not, try entering another code.

Note
Reenter the codes after you change the batteries.

Television code list

Panasonic: 0051, 0250	RCA: 0047
Fisher: 0154	Samsung: 0060, 0587, 0702
GE: 0047	Sanyo: 0154
Gold Star: 0178, 0317, 0457	Sharp: 0093, 0165
Hitachi: 0145	Sony: 0000
JVC: 0053	Sylvania: 0054
Magnavox: 0054	Thomson: 0047
Mitsubishi: 0150	Toshiba: 0156
Philips: 0054	Zenith: 0017
Quasar: 0051, 0250	

One Touch Play

You can turn on the main unit and television, and start playing the disc in the play position with a single press of a button.

Press [ONE TOUCH PLAY].

Note
Playback may not be immediately displayed on the television. If you miss the beginning portion of playback, press [|◀◀] or [◀◀] to go back to where playback started.

Theater speaker

You can select whether audio is output from the home theater system or the television by using the television settings. For details, refer to the operating instructions of your television.

When audio is output from the home theater speakers

- The television speakers are automatically muted.
- You can control the volume setting using the volume or mute button on the television remote control. (The volume level is displayed on the main unit’s FL display.)
- If you turn off the home theater system, speakers automatically switch to the television.

When audio is output from the television speakers

- The volume of the home theater system is set to “0”.
- Audio output is 2-channel audio.

- To cancel muting, you can also use the home theater remote control (→ page 31, Muting the sound).
- When switching between the home theater system and television speakers, the TV screen may be blank for several seconds.

Power off link

When the television is turned off, the home theater system goes into standby mode automatically.

- This function works only when “DVD/CD” or “TV” is selected as the source on the home theater system.

Using other useful functions

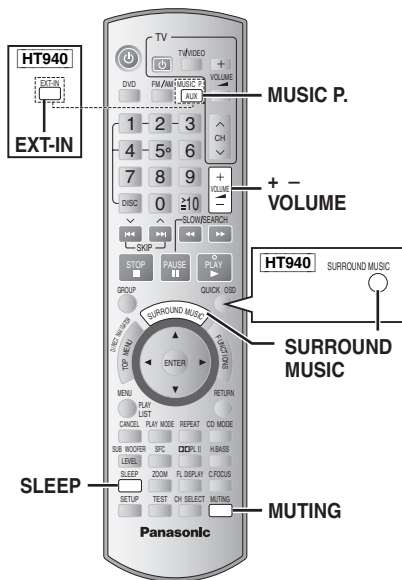

Setting the sleep timer

SLEEP

Press [SLEEP] to select the time (in minutes).

SLEEP 30 → SLEEP 60 → SLEEP 90
 ↑ OFF ← SLEEP 120 ←

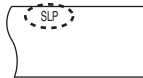

To cancel the timer

Press [SLEEP] to select "OFF".

To confirm the remaining time

Press [SLEEP] again.

To change the setting

Repeat the procedure from the beginning.

Muting the sound

MUTING

Press [MUTING].

"MUTING" flashes on the unit's display.



To cancel

- Press [MUTING] again or reduce the volume to minimum "VOL 0", and then raise it to the required level.
- Muting is canceled when you switch the unit to standby.

Using headphones

Main unit only

- 1 Reduce the volume and connect the headphones (not included).

Headphone plug type: Ø3.5 mm (1/8") stereo mini plug



- 2 Adjust headphone volume with [VOLUME].

- Audio is automatically switched to 2-channel stereo.

Note

To prevent hearing damage, avoid listening for prolonged periods of time.

Using the Music Port

The Music Port allows you to connect and enjoy music from an external device (e.g. MP3 player) through your home theater system.

Preparation

To avoid distorted sound, make sure that any equalizer function of your external device is turned off.

- 1 Reduce the volume and connect the external device (not included).

Plug type: Ø3.5 mm (1/8") stereo mini plug

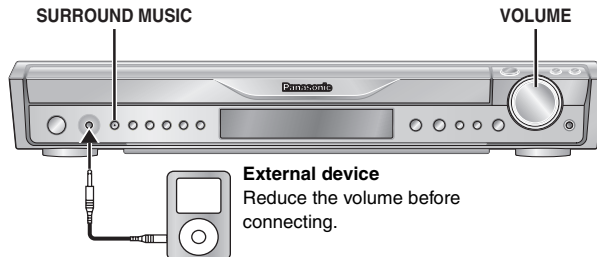

External device
 Reduce the volume before connecting.

- 2 Press [MUSIC P.] ([HT940] [EXT-IN]) to select "FRONT MUSIC P."

FRONT MUSIC P. → REAR MUSIC P.* → (HT940 TV)
 ↑ AUX ←



* **U.S.A. and Canada** "REAR MUSIC P." can be selected only if the optional Panasonic wireless accessory (e.g. SH-FX60) is set up with your home theater system. For details, please refer to its operating instructions.

- 3 Adjust the external device volume to a normal listening level, and then adjust the volume of the main unit with [VOLUME].

- You can enjoy surround sound when you press [SURROUND MUSIC] on the main unit (**U.S.A. and Canada** except when "REAR MUSIC P." is selected).



Troubleshooting guide

Before requesting service, make the following checks. If you are in doubt about some of the check points, or if the solutions indicated in the chart do not solve the problem, refer to "Customer Services Directory" on page 37 if you reside in the U.S.A., or refer to "Product information" on page 13 if you reside in Canada. In other areas, consult your dealer.

Power		Page
No power.	● Insert the AC power supply cord securely.	10
The unit is automatically switched to standby mode.	● The Sleep timer was working and had reached the set time limit.	31

Unresponsive or inoperable function

No response when any buttons are pressed.	<ul style="list-style-type: none"> ● This unit cannot play discs other than the ones listed in these operating instructions. ● The unit may not be operating properly due to lightning, static electricity or some other external factor. Turn the unit off and then back on. Alternatively, turn the unit off, disconnect the AC power supply cord, and then reconnect it. ● Condensation has formed. Wait 1 to 2 hours for it to evaporate. 	12 — —
No response when remote control buttons are pressed.	<ul style="list-style-type: none"> ● Check that the batteries are installed correctly. ● The batteries are depleted. Replace them with new ones. ● Aim the remote control at the display and operate. 	10 10 11
Cannot play DVDs.	● CD Mode is on. Press [CD MODE] to turn CD Mode off.	16
No picture or sound.	<ul style="list-style-type: none"> ● Check the video or speaker connection. ● Check the power or input setting of the connected equipment and the main unit. ● Check that the disc has something recorded on it. 	4, 5, 8, 9 — —
You have forgotten your ratings password. Reset all the settings to Factory Preset.	● While stopped and "DVD/CD" is the source, press and hold [■] (Stop) on the main unit and [≧10] on the remote control until "Initialized" disappears from the television. Turn the unit off and on again. All settings will return to the default values.	—
[HT940] The HDAVI Control function does not respond.	● Depending on the condition of the home theater system or the connected equipment, it may be necessary to repeat the same operation so that the function can work correctly.	30

Specific operation undesirable or unexpected

It takes time before play starts. [MP3]	● Play may take time to begin when an MP3 track has still picture data. Even after the track starts, the correct play time will not be displayed. This is normal.	—
Folders on a data CD are not displayed correctly. [WMA] [MP3] [JPEG]	● Folders deeper than the eighth layer are displayed as the eighth layer.	—
A menu screen appears during skip or search. [VCD]	● This is normal for Video CDs.	—
Playback control menu does not appear. [VCD] with playback control	● Press [■ STOP] twice and then press [▶ PLAY].	—
Program and Random play do not work. [DVD-V]	● These functions do not work with some DVD-Videos.	—
Selecting audio soundtrack "2" does not change the audio. [DVD-A]	● Even if a second soundtrack is not recorded, two numbers are normally shown.	—
Play restarts from the beginning when the soundtrack is changed. [DVD-A]	● This is normal for DVD-Audio.	—

Subtitle

Subtitle position is wrong.	● Adjust the position. ("Subtitle Position" in Display Menu)	22
No subtitles.	● Display the subtitles. ("Subtitle" in Main menu)	20
Subtitles overlap the closed captions.	● Clear the subtitles.	20



Marker		Page
Cannot add markers.	<ul style="list-style-type: none"> You cannot add markers with DVD-RAM or DVD-R/-RW (DVD-VR) discs. If the disc's elapsed play time does not appear on the unit's display, you cannot add markers. 	—
A-B repeat		
Point B is automatically set.	<ul style="list-style-type: none"> The end of an item becomes point B when it is reached. 	—
Sound abnormal or improper		
Sound is distorted.	<ul style="list-style-type: none"> Noise may occur when playing WMA. When using the HDMI output, audio may not be output from other terminals. 	—
Effects do not work.	<ul style="list-style-type: none"> Some audio effects do not work or have less effect with some discs. 	—
Humming is heard during play.	<ul style="list-style-type: none"> An AC power supply cord or fluorescent light is near the main unit. Keep other appliances and cables away from the main unit. 	—
No sound	<ul style="list-style-type: none"> There may be a slight pause in sound when you change the play speed. Audio may not be heard when more than 4 devices are connected with HDMI cables. Reduce the number of connected devices. When using the HDMI connection, ensure that "Audio Output" in the "HDMI" tab is set to "On". 	— — 24
Menus		
The Setup menu cannot be accessed.	<ul style="list-style-type: none"> Select "DVD/CD" as the source. Cancel Program and Random play. 	— 17
Picture abnormal or unviewable		
The picture on the television is not displayed correctly or disappears.	<ul style="list-style-type: none"> Ensure that the unit is connected directly to the television, and is not connected through a video cassette recorder. Mobile telephone chargers can cause some disturbance. If you are using an indoor television antenna, change to an outdoor antenna. The television antenna wire is too close to the unit. Move it away from the unit. Picture may not be seen when more than 4 devices are connected with HDMI cables. Reduce the number of connected devices. When using HDMI output, the video signal is progressive. Use other video connections if your television is not compatible with progressive video. If the picture is distorted or not displayed when using HDMI output, press and hold [CANCEL] until the picture is displayed correctly. (The output will return to "480p".) 	9 — — — 9 —
Picture size does not fit the screen.	<ul style="list-style-type: none"> Change "TV Aspect" in the "Video" tab. Use the television to change the aspect. If your television does not have that function, change "4:3 Aspect" in Display Menu. Change the Zoom setting. 	24 22 16
Menu is not displayed correctly.	<ul style="list-style-type: none"> Restore the zoom ratio to "× 1.00". Set "Subtitle Position" in Display Menu to "0". Set "4:3 Aspect" in Display Menu to "Normal". 	16 22 22
Auto zoom function does not work well.	<ul style="list-style-type: none"> Turn off television's zoom function. Use the other preset aspect ratios or manual adjustment. Zoom function may not work well, especially in dark scenes and may not work depending on the type of disc. 	— 16 —
Progressive video		
There is ghosting when progressive or HDMI output is on.	<ul style="list-style-type: none"> This problem is caused by the editing method or material used on DVD-Video, but should be corrected if you use interlaced output. Set "Video Output Mode" in Picture Menu to "480i". (Alternatively, press and hold [CANCEL] to switch to "480i".) Disable the HDMI AV OUT connection and use other video connections. Make the settings in the following order: <ol style="list-style-type: none"> Set "Video Output" in the "HDMI" tab to "Off". Set "Video Output Mode" in Picture Menu to "480i". (Alternatively, press and hold [CANCEL] to switch to "480i".) 	21 21, 24
Pictures not in progressive output.	<ul style="list-style-type: none"> Select "480p" in "Video Output Mode" in Picture Menu. The unit's VIDEO OUT or S-VIDEO OUT terminal outputs the interlaced signal even if "PRG" is displayed. 	21 9
Closed captions not displayed.	<ul style="list-style-type: none"> When progressive or HDMI output is on, closed captions will not be displayed. 	—
Listening to the radio		
Distorted sound or noise is heard. "ST" flickers or does not light.	<ul style="list-style-type: none"> Adjust the position of the FM or AM antenna. Use an outdoor antenna. 	— 27
A beat sound is heard.	<ul style="list-style-type: none"> Turn the television off or move it away from the unit. 	—
A low hum is heard during AM broadcasts.	<ul style="list-style-type: none"> Separate the antenna from other cables. 	—
Television operation		
Cannot operate the television.	<ul style="list-style-type: none"> Check the remote control code for the television manufacturer. 	30



Unit displays		Page
The display is dark.	<ul style="list-style-type: none"> Select "Bright" in "FL Dimmer" in the "Others" tab. 	24
"NOPLAY"	<ul style="list-style-type: none"> You inserted a disc the unit cannot play; insert one it can. You inserted a blank disc. You inserted a disc that has not been finalized. 	12 — —
"NODISC"	<ul style="list-style-type: none"> You have not inserted a disc; insert one. You have not inserted the disc correctly; insert it correctly. 	— 14
"F61"	<ul style="list-style-type: none"> Check and correct the speaker cable connections. If this does not fix the problem, consult the dealer. 	4, 5, 8
"DVD U11"	<ul style="list-style-type: none"> Disc may be dirty. Wipe it clean. 	12
"ERROR"	<ul style="list-style-type: none"> Incorrect operation performed. Read the instructions and try again. 	—
"DVD H□□"	<ul style="list-style-type: none"> Trouble may have occurred. The numbers following "H" and "F" depend on the status of the unit. Turn the unit off and then back on. Alternatively, turn the unit off, disconnect the AC power supply cord, and then reconnect it. If the service numbers fail to clear, note the service number and contact a qualified service person. 	—
"DVD F□□□"		—
□ stands for a number.		
U.S.A. and Canada	<ul style="list-style-type: none"> There is no link between the main unit and the wireless accessory. Check that the wireless accessory is plugged into the AC outlet. Ensure that the digital transceiver is fully inserted into the slot of the main unit. 	—
"W" is flashing. (When using optional wireless accessory)		—
"D.MIX" is flashing. DVD-A	<ul style="list-style-type: none"> Down-mixing is the process of remixing the multiple-channel audio found on some discs into two channels. The disc contains single-channel or multiple-channel signals which may not be reproduced authentically. 	—
"U701"	<ul style="list-style-type: none"> The connected equipment is not HDMI-compatible. 	—
"U70□"	<ul style="list-style-type: none"> The HDMI connection acts unusually. <ul style="list-style-type: none"> The connected equipment is not HDMI-compatible. The HDMI cable is too long. The HDMI cable is damaged. 	—
□ stands for a number. The actual number following "U70" will depend on the state of the main unit.		—

Television displays

"⊘"	<ul style="list-style-type: none"> The operation is prohibited by the unit or disc. 	—
"Cannot display group xx, content xx"	<ul style="list-style-type: none"> You are trying to display incompatible contents. 	—
"This disc may not be played in your region"	<ul style="list-style-type: none"> Only DVD-Video discs that include or have the same region number as the one on the rear panel of this unit can be played. 	Cover page
"Due to copyright protection, audio cannot be output from HDMI" DVD-A	<ul style="list-style-type: none"> If you connect to equipment that does not support CPPM (→ page 13, Glossary), audio from a CPPM copy-protected DVD-Audio disc cannot be output from the HDMI AV OUT terminal. 	—
No on-screen display.	<ul style="list-style-type: none"> Select "On" in "On-Screen Messages" in the "Display" tab. 	24
Main unit's screen saver remains	<ul style="list-style-type: none"> When using the HDMI connection, audio/video information is continually transferred between the main unit and the television regardless of which source has been selected on the main unit. This is normal. 	—



AMPLIFIER SECTION

HT740 U.S.A. and Canada

RMS Output Power: Dolby Digital Mode

Front Ch	90 W per channel (4 Ω), 1 kHz, 10 % THD
Surround Ch	90 W per channel (4 Ω), 1 kHz, 10 % THD
Center Ch	320 W per channel (4 Ω), 1 kHz, 10 % THD
Subwoofer Ch	320 W per channel (4 Ω), 100 Hz, 10 % THD
Total RMS Dolby Digital mode power	1000 W

FTC Output Power: Dolby Digital Mode

Front Ch	60 W per channel (4 Ω), 120 Hz–20 kHz, 1 % THD
Surround Ch	60 W per channel (4 Ω), 120 Hz–20 kHz, 1 % THD
Center Ch	250 W per channel (4 Ω), 120 Hz–20 kHz, 1 % THD
Subwoofer Ch	250 W per channel (4 Ω), 45 Hz–120 Hz, 1 % THD
Total FTC Dolby Digital mode power	740 W

HT740 Others

RMS Output Power: Dolby Digital Mode

Front Ch	90 W per channel (4 Ω), 1 kHz, 10 % THD
Surround Ch	90 W per channel (4 Ω), 1 kHz, 10 % THD
Center Ch	320 W per channel (4 Ω), 1 kHz, 10 % THD
Subwoofer Ch	320 W per channel (4 Ω), 100 Hz, 10 % THD
Total RMS Dolby Digital mode power	1000 W

FTC Output Power: Dolby Digital Mode

Front Ch	55 W per channel (4 Ω), 120 Hz–20 kHz, 1 % THD
Surround Ch	45 W per channel (4 Ω), 120 Hz–20 kHz, 1 % THD
Center Ch	195 W per channel (4 Ω), 120 Hz–20 kHz, 1 % THD
Subwoofer Ch	210 W per channel (4 Ω), 45 Hz–120 Hz, 1 % THD
Total FTC Dolby Digital mode power	605 W

HT743

RMS Output Power: Dolby Digital Mode

Front Ch	75 W per channel (4 Ω), 1 kHz, 10 % THD
Surround Ch	75 W per channel (4 Ω), 1 kHz, 10 % THD
Center Ch	300 W per channel (4 Ω), 1 kHz, 10 % THD
Subwoofer Ch	300 W per channel (4 Ω), 100 Hz, 10 % THD
Total RMS Dolby Digital mode power	900 W

FTC Output Power: Dolby Digital Mode

Front Ch	50 W per channel (4 Ω), 120 Hz–20 kHz, 1 % THD
Surround Ch	50 W per channel (4 Ω), 120 Hz–20 kHz, 1 % THD
Center Ch	230 W per channel (4 Ω), 120 Hz–20 kHz, 1 % THD
Subwoofer Ch	230 W per channel (4 Ω), 45 Hz–120 Hz, 1 % THD
Total FTC Dolby Digital mode power	660 W

HT940

RMS Output Power: Dolby Digital Mode

Front Ch	190 W per channel (8 Ω), 1 kHz, 10 % THD
Surround Ch	90 W per channel (4 Ω), 1 kHz, 10 % THD
Center Ch	320 W per channel (4 Ω), 1 kHz, 10 % THD
Subwoofer Ch	320 W per channel (4 Ω), 100 Hz, 10 % THD
Total RMS Dolby Digital mode power	1200 W

FTC Output Power: Dolby Digital Mode

Front Ch	120 W per channel (8 Ω), 120 Hz–20 kHz, 1 % THD
Surround Ch	60 W per channel (4 Ω), 120 Hz–20 kHz, 1 % THD
Center Ch	250 W per channel (4 Ω), 120 Hz–20 kHz, 1 % THD
Subwoofer Ch	250 W per channel (4 Ω), 45 Hz–120 Hz, 1 % THD
Total FTC Dolby Digital mode power	860 W

FM/AM TUNER, TERMINALS SECTION

Preset Memory	FM 15 stations AM/MW 15 stations
----------------------	-------------------------------------

Frequency Modulation (FM)	
Frequency range	87.9–107.9 MHz (200-kHz step) 87.5–108.0 MHz (100-kHz step)
Sensitivity	2.5 μV (IHF)
S/N 26 dB	2.2 μV
Antenna terminals	75 Ω (unbalanced)

Amplitude Modulation (AM/MW)	
Frequency range	520–1710 kHz (10-kHz step)
AM Sensitivity S/N 20 dB at 1000 kHz	560 μV/m

Phone jack	
Terminal	Stereo, 3.5 mm (1/8") jack

Music Port (Front)	
Sensitivity	100 mV, 4.7 kΩ
Terminal (Input)	Stereo, 3.5 mm (1/8") jack

DISC SECTION

Discs played [8 cm (3") or 12 cm (5")]

- (1) DVD (DVD-Video, DVD-Audio)
- (2) DVD-RAM (DVD-VR, MP3^{#2,5}, JPEG^{#4,5})
- (3) DVD-R (DVD-Video, DVD-VR, MP3^{#2,5}, JPEG^{#4,5})
- (4) DVD-R DL (DVD-Video, DVD-VR)
- (5) DVD-RW (DVD-Video, DVD-VR, MP3^{#2,5}, JPEG^{#4,5})
- (6) +R/+RW (Video)
- (7) +R DL (Video)
- (8) CD, CD-R/RW [CD-DA, Video-CD, SVCD^{#1}, MP3^{#2,5}, WMA^{#3,5}, JPEG^{#4,5}, HighMAT Level 2 (Audio and Image)]
 - ^{#1} Conforming to IEC62107
 - ^{#2} MPEG-1 Layer 3, MPEG-2 Layer 3
 - ^{#3} Windows Media Audio Ver.9.0 L3
Not compatible with Multiple Bit Rate (MBR)
 - ^{#4} Exif Ver 2.1 JPEG Baseline files
Picture resolution: between 160×120 and 6144×4096 pixels (Sub sampling is 4:0:0, 4:2:0, 4:2:2 or 4:4:4). Extremely long and narrow pictures may not be displayed.
 - ^{#5} The total combined maximum number of recognizable audio and picture contents and groups: 4000 audio and picture contents and 400 groups.

Pick up

Wavelength (DVD/CD)	662/785 nm
Laser power (DVD/CD)	U.S.A. CLASS II/CLASS I Others CLASS 1/CLASS 1M

Audio output (Disc)

Number of channels	5.1ch (FL, FR, C, SL, SR, SW)
--------------------	-------------------------------

VIDEO SECTION

Video system	NTSC
---------------------	------

Composite video output

Output level	1 Vp-p (75 Ω)
Terminal	Pin jack (1 system)

S-video output

Y output level	1 Vp-p (75 Ω)
C output level	NTSC; 0.286 Vp-p (75 Ω)
Terminal	S terminal (1 system)

Component video output (480p/480i)

Y output level	1 Vp-p (75 Ω)
P _B output level	0.7 Vp-p (75 Ω)
P _R output level	0.7 Vp-p (75 Ω)
Terminal	Pin jack (Y: green, P _B : blue, P _R : red) (1 system)

HDMI AV output

Terminal	19-pin type A connector, HDMI Ver.1.2a (EDID Ver.1.3)
----------	---

(Continued on next page)



SPEAKER SECTION

HT740 HT743 Front speakers SB-FS740	
Type	2 way, 2 speaker system (Bass reflex)
Speaker unit(s)	Impedance 4 Ω
1. Woofer	6.5 cm (2 ¹ / ₂ ") Cone type
2. Tweeter	6 cm (2 ³ / ₈ ") Cone type
Input power (IEC)	90 W* (Max)
Output sound pressure	81 dB/W (1.0 m)
Cross over frequency	6 kHz
Frequency range	82 Hz–41 kHz (–16 dB) 95 Hz–40 kHz (–10 dB)
Dimensions (W×H×D)	252 mm×1123 mm×234 mm (9 ²⁹ / ₃₂ "×44 ⁷ / ₃₂ "×9 ⁷ / ₃₂ ")
Mass	3.7 kg (8.2 lbs)

HT740 HT743 Surround speakers SB-FS741	
Type	1 way, 1 speaker system (Bass reflex)
Speaker unit(s)	Impedance 4 Ω
Full range	6.5 cm (2 ¹ / ₂ ") Cone type
Input power (IEC)	90 W* (Max)
Output sound pressure	80 dB/W (1.0 m)
Frequency range	96 Hz–25 kHz (–16 dB) 120 Hz–22 kHz (–10 dB)
Dimensions (W×H×D)	92 mm×135 mm×95.4 mm (3 ⁵ / ₈ "×5 ³ / ₁₆ "×3 ³ / ₄ ")
Mass	0.75 kg (1.65 lbs)

HT740 HT743 Center speaker SB-PC740	
Type	1 way, 2 speaker system (Bass reflex)
Speaker unit(s)	Impedance 4 Ω
1. Full range	6.5 cm (2 ¹ / ₂ ") Cone type
2. Full range	6.5 cm (2 ¹ / ₂ ") Cone type
Input power (IEC)	320 W* (Max)
Output sound pressure	84 dB/W (1.0 m)
Frequency range	105 Hz–25 kHz (–16 dB) 125 Hz–22 kHz (–10 dB)
Dimensions (W×H×D)	270 mm×92 mm×95.4 mm (10 ⁵ / ₈ "×3 ⁵ / ₈ "×3 ³ / ₄ ")
Mass	1.25 kg (2.75 lbs)

HT740 HT743 Subwoofer SB-W740	
Type	1 way, 1 speaker system (Bass reflex)
Speaker unit(s)	Impedance 4 Ω
Woofer	16 cm (6 ¹ / ₂ ") Cone type
Input power (IEC)	320 W (Max)
Output sound pressure	80 dB/W (1.0 m)
Frequency range	32 Hz–220 Hz (–16 dB) 38 Hz–180 Hz (–10 dB)
Dimensions (W×H×D)	183 mm×396 mm×267 mm (7 ⁷ / ₃₂ "×15 ¹⁹ / ₃₂ "×10 ¹ / ₂ ")
Mass	4 kg (8.8 lbs)

HT940 Front speakers SB-FS940	
Speaker box	
Type	2 way, 3 speaker system (Bass reflex)
Speaker unit(s)	Impedance 8 Ω
1. Woofer	6.5 cm (2 ¹ / ₂ ") Cone type
2. Woofer	6.5 cm (2 ¹ / ₂ ") Cone type
3. Tweeter	6 cm (2 ³ / ₈ ") Cone type
Input power (IEC)	190 W* (Max)
Output sound pressure	85 dB/W (1.0 m)
Cross over frequency	7 kHz
Frequency range	91 Hz–30 kHz (–16 dB) 104 Hz–25 kHz (–10 dB)
Dimensions (W×H×D)	110 mm×1000 mm×81 mm (4 ¹¹ / ₃₂ "×39 ³ / ₈ "×3 ³ / ₁₆ ")
Mass	2.4 kg (5.3 lbs)
Full assembly with Stand Base	
Dimensions (W×H×D) (Max)	258 mm×1350 mm×269 mm (10 ⁵ / ₃₂ "×53 ³ / ₃₂ "×10 ¹⁹ / ₃₂ ")
Dimensions (W×H×D) (Min)	258 mm×1100 mm×269 mm (10 ⁵ / ₃₂ "×43 ¹ / ₄ "×10 ¹⁹ / ₃₂ ")
Mass	5.2 kg (11.5 lbs)

HT940 Surround speakers SB-FS941	
Type	1 way, 1 speaker system (Bass reflex)
Speaker unit(s)	Impedance 4 Ω
Full range	6.5 cm (2 ¹ / ₂ ") Cone type
Input power (IEC)	90 W* (Max)
Output sound pressure	79 dB/W (1.0 m)
Frequency range	84 Hz–25 kHz (–16 dB) 96 Hz–22 kHz (–10 dB)
Dimensions (W×H×D)	92 mm×270 mm×97 mm (3 ⁵ / ₈ "×10 ⁵ / ₈ "×3 ¹³ / ₁₆ ")
Mass	0.7 kg (1.5 lbs)

HT940 Center speaker SB-PC940	
Type	2 way, 3 speaker system (Bass reflex)
Speaker unit(s)	Impedance 4 Ω
1. Woofer	6.5 cm (2 ¹ / ₂ ") Cone type
2. Woofer	6.5 cm (2 ¹ / ₂ ") Cone type
3. Tweeter	6 cm (2 ³ / ₈ ") Cone type
Input power (IEC)	320 W* (Max)
Output sound pressure	84 dB/W (1.0 m)
Cross over frequency	7 kHz
Frequency range	103 Hz–30 kHz (–16 dB) 120 Hz–25 kHz (–10 dB)
Dimensions (W×H×D)	320 mm×92 mm×90 mm (12 ¹⁹ / ₃₂ "×3 ⁵ / ₈ "×3 ⁷ / ₃₂ ")
Mass	1.4 kg (3.1 lbs)

HT940 Subwoofer SB-W940	
Type	1 way, 1 speaker system (Bass reflex)
Speaker unit(s)	Impedance 4 Ω
Woofer	17 cm (6 ³ / ₄ ") Cone type
Input power (IEC)	320 W (Max)
Output sound pressure	81 dB/W (1.0 m)
Frequency range	29 Hz–160 Hz (–16 dB) 34 Hz–135 Hz (–10 dB)
Dimensions (W×H×D)	235 mm×448 mm×397 mm (9 ¹ / ₄ "×17 ⁵ / ₈ "×15 ⁵ / ₈ ")
Mass	6.7 kg (14.8 lbs)

GENERAL

Power supply	
U.S.A. and Canada	AC 120 V, 60 Hz
Others	AC 110-127 V/220-240 V, 50/60 Hz
Power consumption	
HT740 U.S.A. and Canada	Main unit 140 W
HT740 Others	Main unit 155 W
HT743	Main unit 140 W
HT940	Main unit 150 W
Dimensions (W×H×D)	430 mm×70 mm×439.2 mm (16 ¹⁵ / ₁₆ "×2 ³ / ₄ "×17 ¹⁹ / ₆₄ ")
Mass	Main unit 5.0 kg (11.02 lbs)
Operating temperature range	+5 °C to +35 °C (+41 °F to +95 °F)
Operating humidity range	5 % to 90 % RH (no condensation)

Power consumption in standby mode

U.S.A. and Canada	approx. 0.4 W
Others	approx. 0.9 W

* Rating with low-cut filter equipped amplifier

Note

- Specifications are subject to change without notice. Mass and dimensions are approximate.
- Total harmonic distortion is measured by a digital spectrum analyzer.

User memo:

DATE OF PURCHASE	_____
DEALER NAME	_____
DEALER ADDRESS	_____
TELEPHONE NUMBER	_____

The model number and serial number of this product can be found on either the back or the bottom of the unit. Please note them in the space provided below and keep for future reference.

MODEL NUMBER	_____
SERIAL NUMBER	_____



Limited Warranty (ONLY FOR U.S.A.)

Panasonic Consumer Electronics Company,
Division of Panasonic Corporation of North America
One Panasonic Way Secaucus, New Jersey 07094

Panasonic Puerto Rico, Inc.
Ave. 65 de Infantería, Km. 9.5
San Gabriel Industrial Park, Carolina, Puerto Rico 00985

Panasonic Audio Products Limited Warranty

Limited Warranty Coverage

If your product does not work properly because of a defect in materials or workmanship, Panasonic Consumer Electronics Company or Panasonic Puerto Rico, Inc. (collectively referred to as "the warrantor") will, for the length of the period indicated on the chart below, which starts with the date of original purchase ("warranty period"), at its option either (a) repair your product with new or refurbished parts, or (b) replace it with a new or a refurbished product. The decision to repair or replace will be made by the warrantor.

Product or Part Name	Parts	Labor
Audio Products (except items listed below)	One (1) year	One (1) year
USB Reader-Writer, Personal Computer Card Adapters (in exchange for defective item)	One (1) year	Not Applicable
Accessories: Headphones, Cartridges, Microphones, Adapters	Ninety (90) days	Ninety (90) days
Rechargeable Batteries, DVD-R/-RAM Discs (in exchange for defective item)	Ten (10) days	Not Applicable
SD Memory Cards, Rechargeable Battery Packs (in exchange for defective item)	Ninety (90) days	Not Applicable

During the "Labor" warranty period there will be no charge for labor. During the "Parts" warranty period, there will be no charge for parts. You must carry-in or mail-in your product during the warranty period. If non-rechargeable batteries are included, they are not warranted. This warranty only applies to products purchased and serviced in the United States or Puerto Rico. This warranty is extended only to the original purchaser of a new product which was not sold "as is". A purchase receipt or other proof of the original purchase date is required for warranty service.

Carry-In or Mail-In Service

For Carry-In or Mail-In Service in the United States call 1-800-211-PANA (1-800-211-7262) or visit Panasonic web site: <http://www.panasonic.com>
For assistance in Puerto Rico call Panasonic Puerto Rico, Inc. (787)-750-4300 or fax (787)-768-2910.

Limited Warranty Limits And Exclusions

This warranty ONLY COVERS failures due to defects in materials or workmanship, and DOES NOT COVER normal wear and tear or cosmetic damage. The warranty ALSO DOES NOT COVER damages which occurred in shipment, or failures which are caused by products not supplied by the warrantor, or failures which result from accidents, misuse, abuse, neglect, mishandling, misapplication, alteration, faulty installation, set-up adjustments, misadjustment of consumer controls, improper maintenance, power line surge, lightning damage, modification, or commercial use (such as in a hotel, office, restaurant, or other business), rental use of the product, service by anyone other than a Factory Servicenter or other Authorized Servicer, or damage that is attributable to acts of God.

THERE ARE NO EXPRESS WARRANTIES EXCEPT AS LISTED UNDER "LIMITED WARRANTY COVERAGE". THE WARRANTOR IS NOT LIABLE FOR INCIDENTAL OR CONSEQUENTIAL DAMAGES RESULTING FROM THE USE OF THIS PRODUCT, OR ARISING OUT OF ANY BREACH OF THIS WARRANTY. (As examples, this excludes damages for lost time, travel to and from the servicer, loss of media or images, data or other memory content. The items listed are not exclusive, but are for illustration only.) **ALL EXPRESS AND IMPLIED WARRANTIES, INCLUDING THE WARRANTY OF MERCHANTABILITY, ARE LIMITED TO THE PERIOD OF THE LIMITED WARRANTY.**

Some states do not allow the exclusion or limitation of incidental or consequential damages, or limitations on how long an implied warranty lasts, so the exclusions may not apply to you. This warranty gives you specific legal rights and you may also have other rights which vary from state to state. If a problem with this product develops during or after the warranty period, you may contact your dealer or Servicenter. If the problem is not handled to your satisfaction, then write to the warrantor's Consumer Affairs Department at the addresses listed for the warrantor.

PARTS AND SERVICE WHICH ARE NOT COVERED BY THIS LIMITED WARRANTY ARE YOUR RESPONSIBILITY.

Customer Services Directory

Obtain Product Information and Operating Assistance; locate your nearest Dealer or Servicenter; purchase Parts and

Accessories; or make Customer Service and Literature requests by visiting our Web Site at:

<http://www.panasonic.com/consumersupport>

or, contact us via the web at:

<http://www.panasonic.com/contactinfo>

You may also contact us directly at:

1-800-211-PANA (7262),

Monday-Friday 9 am-9 pm; Saturday-Sunday 10 am-7 pm, EST.

For hearing or speech impaired TTY users, TTY : 1-877-833-8855

Accessory Purchases

Purchase Parts, Accessories and Instruction Books online for all Panasonic Products by visiting our Web Site at:

<http://www.pasc.panasonic.com>

or, send your request by E-mail to:

npcparts@us.panasonic.com

You may also contact us directly at:

1-800-332-5368 (Phone) 1-800-237-9080 (Fax Only) (Monday – Friday 9 am to 8 pm, EST.)

Panasonic Services Company

20421 84th Avenue South, Kent, WA 98032

(We Accept Visa, MasterCard, Discover Card, American Express, and Personal Checks)

For hearing or speech impaired TTY users, TTY : 1-866-605-1277

Service in Puerto Rico

Panasonic Puerto Rico, Inc.

Ave. 65 de Infantería, Km. 9.5, San Gabriel Industrial Park, Carolina, Puerto Rico 00985

Phone (787)750-4300, Fax (787)768-2910

Limited Warranty (ONLY FOR U.S.A.)



FQ18582

Limited Warranty (ONLY FOR CANADA)

Panasonic Canada Inc.

PANASONIC/TECHNICS PRODUCT – LIMITED WARRANTY

Panasonic Canada Inc. warrants this product to be free from defects in material and workmanship and agrees to remedy any such defect for a period as stated below from the date of original purchase.

Technics Audio Product
Panasonic Audio & DVD Product
Accessories including rechargeable batteries

One (1) year, parts and labour
One (1) year, parts and labour
Ninety (90) days

In-home Service will be carried out only to locations accessible by roads and within 50 km of an authorized Panasonic service facility.

LIMITATIONS AND EXCLUSIONS

This warranty does not apply to products purchased outside Canada or to any product which has been improperly installed, subjected to usage for which the product was not designed, misused or abused, damaged during shipping, or which has been altered or repaired in any way that affects the reliability or detracts from the performance, nor does it cover any product which is used commercially. Dry cell batteries are also excluded from coverage under this warranty.

This warranty is extended to the original end user purchaser only. A purchase receipt or other proof of date of original purchase is required before warranty service is performed.

THIS EXPRESS, LIMITED WARRANTY IS IN LIEU OF ALL OTHER WARRANTIES, EXPRESS OR IMPLIED, INCLUDING ANY IMPLIED WARRANTIES OF MERCHANTABILITY AND FITNESS FOR A PARTICULAR PURPOSE.

IN NO EVENT WILL PANASONIC CANADA INC. BE LIABLE FOR ANY SPECIAL, INDIRECT OR CONSEQUENTIAL DAMAGES.

In certain instances, some jurisdictions do not allow the exclusion or limitation of incidental or consequential damages, or the exclusion of implied warranties, so the above limitations and exclusions may not be applicable.

WARRANTY SERVICE

FOR PRODUCT OPERATION ASSISTANCE, please contact:

Our Customer Care Centre:	Telephone #:	(905) 624-5505
	1-800 #:	1-800-561-5505
	Fax #:	(905) 238-2360
	Email link:	"Contact Us" on www.panasonic.ca

FOR PRODUCT REPAIRS, please locate your nearest Authorized Servicentre at www.panasonic.ca :

Link : "Servicentres™ locator" under "Customer support"

Panasonic Factory Service:

Richmond British Columbia
Panasonic Canada Inc.
12111 Riverside Way
Richmond BC V6W 1K8
Tel: (604) 278-4211
Fax: (604) 278-5627

Mississauga Ontario
Panasonic Canada Inc.
5770 Ambler Drive
Mississauga ON L4W 2T3
Tel: (905) 624-8447
Fax: (905) 238-2418

IF YOU SHIP THE PRODUCT TO A SERVICENTRE

Carefully pack and send prepaid, adequately insured and preferably in the original carton.
Include details of the defect claimed, and proof of date of original purchase.



Listening caution



Selecting fine audio equipment such as the unit you've just purchased is only the start of your musical enjoyment. Now it's time to consider how you can maximize the fun and excitement your equipment offers. This manufacturer and the Electronic Industries Association's Consumer Electronics Group want you to get the most out of your equipment by playing it at a safe level. One that lets the sound come through loud and clear without annoying blaring or distortion—and, most importantly, without affecting your sensitive hearing.

We recommend that you avoid prolonged exposure to excessive noise.

Sound can be deceiving. Over time your hearing "comfort level" adapts to higher volumes of sound. So what sounds "normal" can actually be loud and harmful to your hearing.

Guard against this by setting your equipment at a safe level BEFORE your hearing adapts.

To establish a safe level:

- Start your volume control at a low setting.
- Slowly increase the sound until you can hear it comfortably and clearly, and without distortion.

Once you have established a comfortable sound level:

- Set the dial and leave it there.

Taking a minute to do this now will help to prevent hearing damage or loss in the future. After all, we want you listening for a lifetime.

Manufactured under license from Dolby Laboratories. "Dolby", "Pro Logic" and the double-D symbol are trademarks of Dolby Laboratories.

"DTS" and "DTS Digital Surround" are registered trademarks of Digital Theater Systems, Inc.

Apparatus Claims of U.S. Patent Nos. 4,631,603, 4,577,216, and 4,819,098, licensed for limited viewing uses only.

This product incorporates copyright protection technology that is protected by method claims of certain U.S. patents and other intellectual property rights owned by Macrovision Corporation and other rights owners. Use of this copyright protection technology must be authorized by Macrovision Corporation, and is intended for home and other limited viewing uses only unless otherwise authorized by Macrovision Corporation. Reverse engineering or disassembly is prohibited.

MPEG Layer-3 audio decoding technology licensed from Fraunhofer IIS and Thomson multimedia.

Windows Media, and the Windows logo are trademarks, or registered trademarks of Microsoft Corporation in the United States and/or other countries.

WMA is a compression format developed by Microsoft Corporation. It achieves the same sound quality as MP3 with a file size that is smaller than that of MP3.



HighMAT™ and the HighMAT logo are either trademarks or registered trademarks of Microsoft Corporation in the United States and/or other countries.



HDCCD®, HDCCD®, High Definition Compatible Digital® and Pacific Microsonics™ are either registered trademarks or trademarks of Pacific Microsonics, Inc. in the United States and/or other countries.

HDCCD system manufactured under license from Pacific Microsonics, Inc. This product is covered by one or more of the following: In the USA: 5,479,168, 5,638,074, 5,640,161, 5,808,574, 5,838,274, 5,854,600, 5,864,311, 5,872,531, and in Australia: 669114, with other patents pending.

HDMI, the HDMI logo and High-Definition Multimedia Interface are trademarks or registered trademarks of HDMI Licensing LLC.

HDAVI Control™ is a trademark of Matsushita Electric Industrial Co., Ltd.



















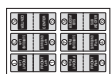

Accessories



Please check and identify the supplied accessories. Use numbers indicated in parentheses when asking for replacement parts. (Product numbers correct as of December 2005. These may be subject to change.)

Only for U.S.A.: To order accessories, refer to "Accessory Purchases" on page 37.

For other areas: To order accessories, call the dealer from whom you made your purchase.

- | | | | | |
|---|--|---|--|---|
| <p><input type="checkbox"/> 1 Remote control
HT740 HT743
(EUR7662Y30)
HT940
(EUR7662Y40)</p>  <p><input type="checkbox"/> 2 Remote control batteries</p>  <p><input type="checkbox"/> 1 AM loop antenna
(N1DAAA00002)</p>  <p><input type="checkbox"/> 1 FM indoor antenna
(RSA0007-L)</p>  | <p><input type="checkbox"/> 1 Video cable
(K2KA2BA00001)</p>  <p><input type="checkbox"/> Speaker cables
HT740 HT743
1× short cable
(REEX0449B-2L)
HT940 2× short cables
(REEX0449B-1L)</p>  <p>HT740 HT743
2× long cables
(REEX0449E-2K)
HT940 2× long cables
(REEX0449E-2)</p>  <p><input type="checkbox"/> 2 Sheets of speaker cable stickers</p>  | <p><input type="checkbox"/> 2 Stands HT740 HT743
(RYPX0128-S)</p>  <p><input type="checkbox"/> 2 Bases HT740 HT743
(RYPX0120-S)</p>  <p><input type="checkbox"/> 8 Screws HT740 HT743
(XSN5+12FJ)</p>  <p><input type="checkbox"/> 2 Cover plates
HT740 HT743
(RGPX0239-K)</p>  | <p><input type="checkbox"/> 2 Stands HT940
(RYQX0246-S)</p>  <p><input type="checkbox"/> 2 Bases HT940
(RYQX0267-S)</p>  <p><input type="checkbox"/> 6 Screws HT940
(RHDX50004-1)</p>  <p><input type="checkbox"/> 2 Sliders HT940
(RMAX0093-S)</p>  | <p><input type="checkbox"/> 1 AC power supply cord
U.S.A. and Canada
(K2CB2CB00018)</p>  <p>Others
(K2CQ2CA00002)</p>  <p>For areas except U.S.A. and Canada</p> <p><input type="checkbox"/> 1 Power plug adaptor
(K2DA42E00001)</p>  |
|---|--|---|--|---|

This product may receive radio interference caused by mobile telephones during use. If such interference is apparent, please increase separation between the product and the mobile telephone.

For units with PX printed on the outer packaging
THIS UNIT IS INTENDED FOR USE IN MODERATE CLIMATES.

-If you see this symbol-

Information on Disposal in other Countries outside the European Union



This symbol is only valid in the European Union. If you wish to discard this product, please contact your local authorities or dealer and ask for the correct method of disposal.

CAUTION	- LASER RADIATION WHEN OPEN. DO NOT STARE INTO BEAM. FDA 21 CFR / Class II
CAUTION	- CLASS 1M VISIBLE AND INVISIBLE LASER RADIATION WHEN OPEN. DO NOT VIEW DIRECTLY WITH OPTICAL INSTRUMENTS. IEC60825-1 +A2/ Class 1M
WARNING	- KLASS 1M SYNLIS OG OSYNLIG LASERSTRÅLING NÅR DENNA DEL ÄR ÖPPNAD. BETRÄKTA EJ STRÅLEN DIREKT GENOM OPTIKT INSTRUMENT.
FORSIGTIG	- SYNLIS OG OSYNLIG LASERSTRÅLING KLASSE 1M. IKK LAGET ER SIKRE. UNNSIK ÅT SE DIREKT PÅ OPTISKE INSTRUMENTER.
VARO!	- HUHTRESSA OLET ALTINNA LUOKAN 1M NÄKYNÄÄ JA NÄKYMÄNTÄ. LASERISÄTELYÄ. ÄLÄ KATSO OPTISELLA LAITTEELLA SUORAAN SÄTEESEEN.
VORSICHT	- SICHTBARE UND UNSICHTBARE LASERSTRÄHLUNG KLASSE 1M. WENN ABDECKUNG GEÖFFNET, NICHT DIREKT MIT OPTISCHEN INSTRUMENTEN BETRACHTEN.
ATTENTION	- RAYONNEMENT LASER VISIBLE ET INVISIBLE, CLASSE 1M. EN CAS D'OUVERTURE, NE PAS REGARDER DIRECTEMENT À L'AIDE D'INSTRUMENTS D'OPTIQUE.
注意	- ここを開くと可視及び不可視レーザー光が出ます。 ビームを視たり、触れたりしないでください。
注意	- 打开时有可见及不可见激光辐射。避免光束照射。 GG7241-1-2001/GB 2894 RQLXS0075

(Inside of product)

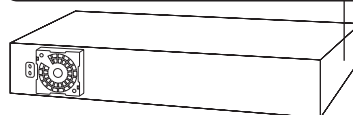

(Side of product)

The laser product label has not been attached to products for the U.S.A. and Canada.

For U.S.A.

Panasonic Consumer Electronics Company, Division of Panasonic Corporation of North America
One Panasonic Way Secaucus,
New Jersey 07094
<http://www.panasonic.com>

Panasonic Puerto Rico, Inc.

Ave. 65 de Infantería, Km. 9.5
San Gabriel Industrial Park, Carolina,
Puerto Rico 00985

For Canada

Panasonic Canada Inc.
5770 Ambler Drive
Mississauga, Ontario
L4W 2T3
www.panasonic.ca

For others

Matsushita Electric Industrial Co., Ltd.
Corporate Management Division for the Americas
Sales Office for North America
Tokyo Panasonic Sales Section
32nd Floor, World Trade Center 4-1,
Hamamatsu-cho, 2-Chome, Minato-Ku,
Tokyo 105-6132, Japan

Panasonic Marketing Europe G.M.B.H.
Wiesbaden N. (a Division of Panasonic Marketing G.M.B.H.) Military Sales Department
6200 Wiesbaden-Biebrich, Hagenauerstr. 43
Germany

En