

# SC0163D ChiPhy™ Family

## Charger Interface Physical Layer IC

**PRELIMINARY**

### Product Highlights

- Supports Quick Charge 2.0 Class A specification
  - 5 V, 9 V, and 12 V output voltage
- Supports Quick Charge 3.0 Class A specification
  - 3.6 V to 12 V output voltage
- USB battery charging specification revision 1.2 compatible
  - Automatic USB DCP shorting D+ to D- line
  - Default 5 V mode operation
- Very low power consumption
  - Below 1 mW at 5 V output
- Fail safe operation
  - Adjacent pin-to-pin short-circuit fault
  - Open-circuit pin fault
- Supports InnoSwitch, TinySwitch and TOPSwitch

### Typical Applications

- Battery chargers for smart phones, tablets, netbooks, digital cameras, and bluetooth accessories
- USB power output ports such as battery banks or car chargers

### Description

SC0163D is a low-cost USB high-voltage dedicated charging port (HVDCP) interface IC for the Quick Charge 3.0 specification. It incorporates all necessary functions to add Quick Charge 3.0 capability to Power Integrations' switcher ICs such as InnoSwitch, TinySwitch, TOPSwitch and other solutions employing traditional secondary-side feedback schemes.

SC0163D supports the full output voltage range of Class A per Quick Charge 3.0 specification.

SC0163D automatically detects whether a connected (PD) is Quick Charge 3.0 or Quick Charge 2.0 capable before enabling output voltage adjustment. If a PD not compliant to Quick Charge 2.0 or 3.0 is detected the SC0163D disables output voltage adjustment to ensure safe operation with legacy 5 V only USB PDs.

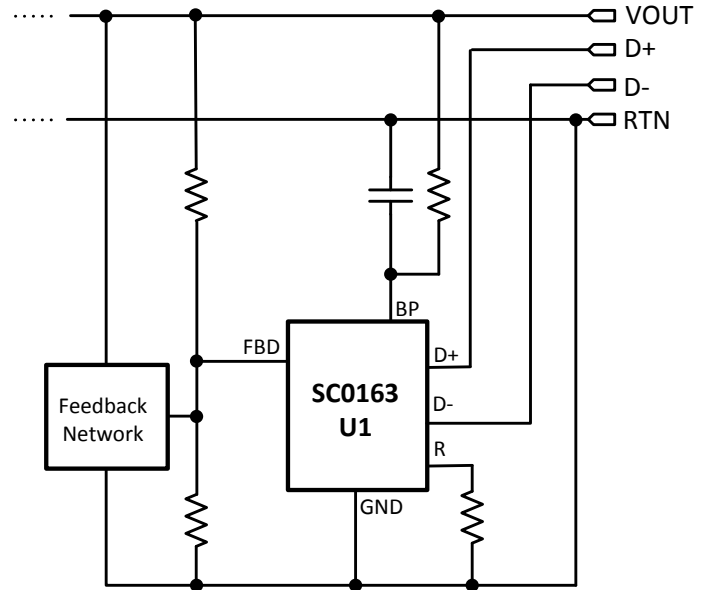

Figure 1. Typical Application Schematic.



FP6600Q 完美代替 CHY103D, SC0163D。  
还多了支持华为FCP快充, 和苹果识别 (1A, 2A, 2.4A)  
SO-8 (D Package)

FP6600Q <http://www.szparkson.net/product/214.html>

Figure 2. Package Option.

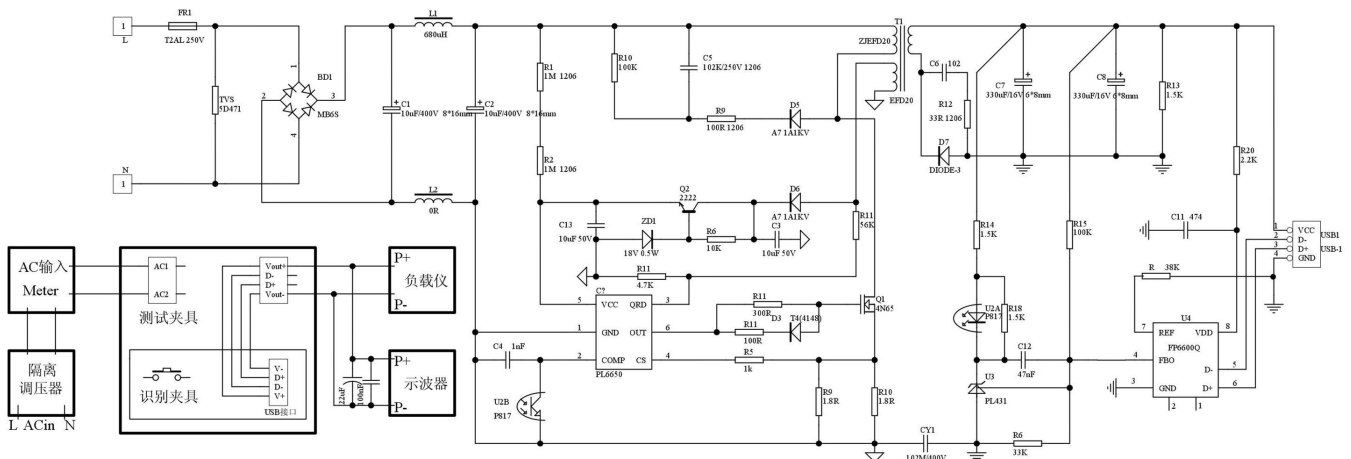

QC3.0 PL6650 + FP6600Q 原理图



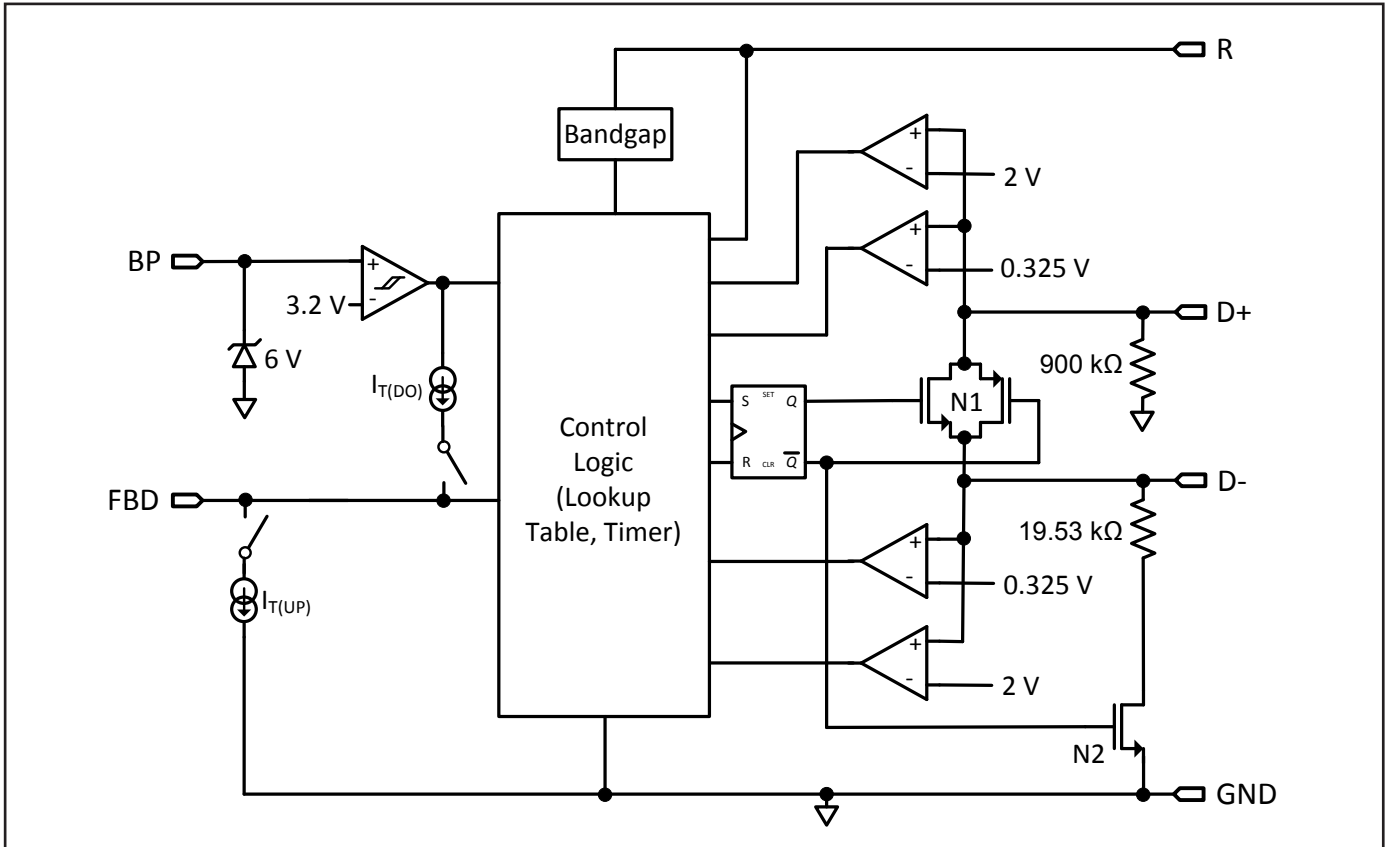

Figure 3. Functional Block Diagram.

**Pin Functional Description**

**GROUND (GND) Pin:**

Ground.

**FEEDBACK DRIVE (FBD) Pin:**

Feedback loop drive output connected to reference input of external power supply error amplifier to set output voltage.

**BYPASS (BP) Pin:**

Connection point for an external bypass capacitor for the internally generated supply voltage.

**REFERENCE (R) Pin:**

Connected to internal band-gap reference. Provides reference current through connected resistor.

**DATA LINE (D+) Pin:**

USB D+ data line input.

**DATA LINE (D-) Pin:**

USB D- data lien input.

**NOT CONNECTED (NC) Pins:**

Pin 1 needs to be connected to BYPASS pin on the PCB.

Pin 2 needs to be connected to the GROUND pin on the PCB.

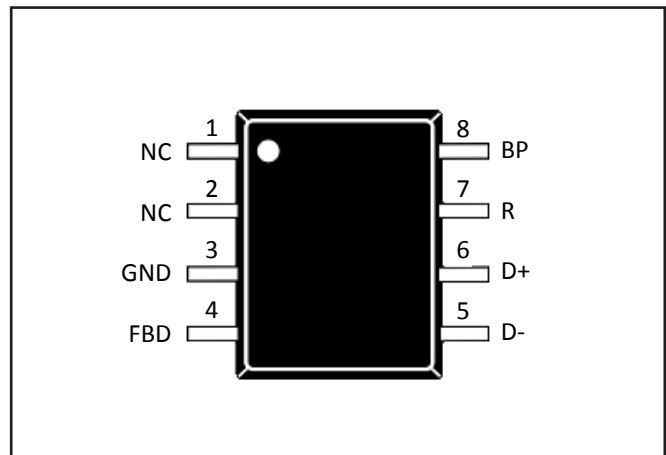

Figure 4. Pin Configuration.

**Functional Description**

SC0163D is a low-cost USB high-voltage dedicated charging port (HVDCP) interface IC for the Quick Charge 3.0 specification. It incorporates all necessary functions to add Quick Charge 3.0 capability to Power Integrations' switcher ICs such as InnoSwitch, TinySwitch, and TOPSwitch.

SC0163D also supports other solutions with traditional secondary-side feedback schemes such as TL431 for instance.

Figure 5 depicts SC0163D interfacing with Power Integrations' InnoSwitch switcher IC.

SC0163D supports the full output range of Quick Charge 3.0 Class A (3.6 V to 12 V) and its subset Quick Charge 2.0 Class A (5 V, 9 V, or 12 V). It automatically detects either Quick Charge 3.0 or Quick Charge 2.0 capable powered devices (PD) or legacy PDs compliant with USB Battery Charging Specification revision 1.2 and only enables output voltage adjustments accordingly.

**Shunt Regulator**

The internal shunt regulator clamps the BYPASS pin at 6 V when current is provided through an external resistor ( $R_{BP}$  in Figure 5). This facilitates powering SC0163D externally over a wide output voltage range of 3.6 V to 20 V. Recommended values are  $R_{BP} = 2.21 \text{ k}\Omega \pm 1\%$  and  $C_{BP} = 470 \text{ nF}$ .

**BYPASS Pin Undervoltage**

The BYPASS pin undervoltage circuitry resets the SC0163D when the BYPASS pin voltage drops below 2.87 V. Once the BYPASS pin voltage drops below 2.87 V it must rise back to 3.1 V to commence correct operation.

**Reference and Output Voltage Range Selection Input**

Resistor  $R_{REF}$  at the REFERENCE pin is connected to an internal band gap reference and provides an accurate reference current for internal timing circuits. Recommended value is  $R_{REF} = 38.3 \text{ k}\Omega \pm 1\%$ .

**Quick Charge 3.0 Interface**

At power-up SC0163D turns on switch N1 (see Figure 3) short-circuiting USB data lines D+ and D- for the initial handshake between

AC-DC adapter (DCP) and powered device (PD) as described in the USB Battery Charging specification revision 1.2. After the USB BC 1.2 handshake is completed, SC0163D will turn off switch N1 if it detects a Quick Charge 3.0 or Quick Charge 2.0 compliant PD. At this point the Quick Charge 2.0 handshake followed by the Quick Charge 3.0 handshake can take place as described in the Quick Charge 2.0 and Quick Charge 3.0 protocol specification. Upon completion of the Quick Charge 2.0 and Quick Charge 3.0 handshakes, SC0163D will turn on switch N2 (see Figure 3) connecting a 19.53 k $\Omega$  pull-down resistor to USB data line D-.

Table 1 summarizes the output voltage lookup and model select table and corresponding AC-DC adapter output voltages.

Portable Device (PD)		SC0163D	
D+	D-	Power Supply Output	Note
0.6 V	0.6 V	12 V	
3.3 V	0.6 V	9 V	
0.6 V	3.3 V	Continuous Mode	$\pm 0.2 \text{ V}$ step size
0.6 V	GND	5 V	Default mode

Table 1. Quick Charge 3.0 Output Voltage Lookup and Mode Select Table.

When the USB cable is unplugged the voltage level at D+ is pulled down by SC0163D's internal resistor (see Figure 3). Once it drops below 0.325 V SC0163D will enter default mode (switch N1 is on, switch N2 is off) and sets the default output voltage of 5 V.

**Feedback Loop Drive**

SC0163D sets the respective output power supply voltage regulation point by directly driving the reference input of the power supply control loop error amplifier through an internal current sink  $I_{T(UP)}$  and source  $I_{T(DO)}$  (see Figure 6).

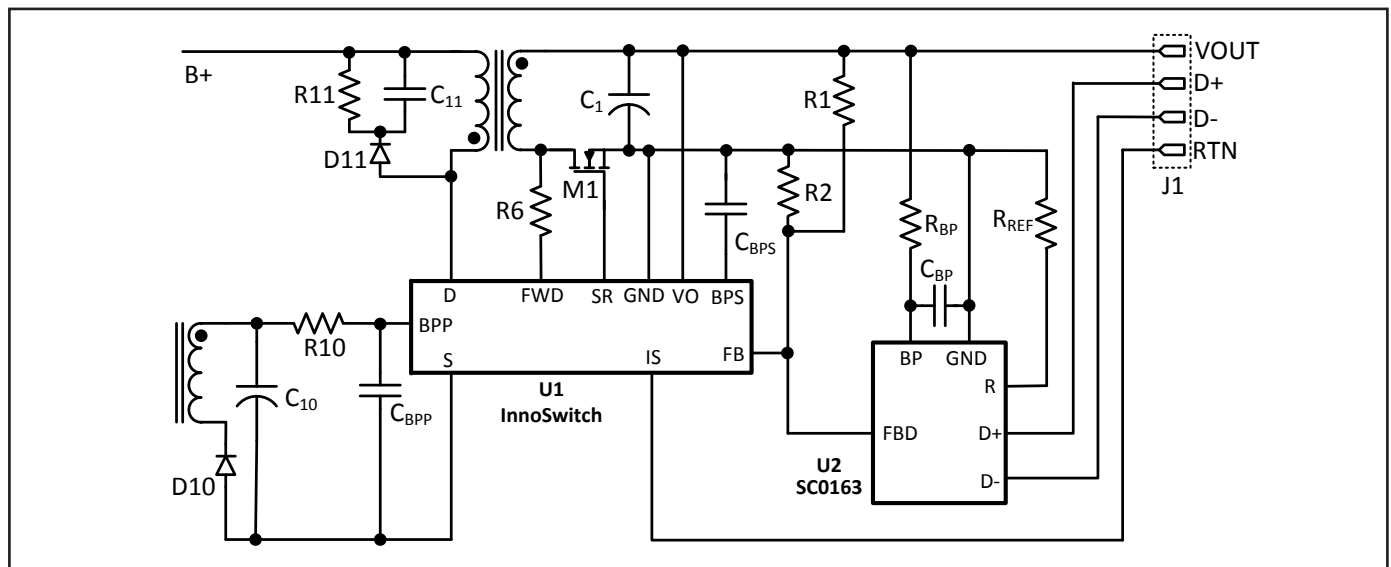

Figure 5. SC0163D with Power Integrations InnoSwitch Switcher IC.

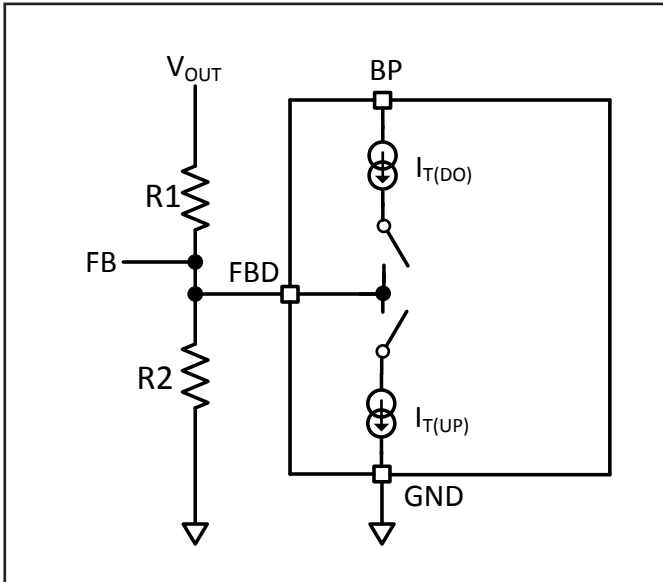

Figure 6. SC0163D FEEDBACK Pin Drive Output.

In default mode with a 5 V output both, the internal current source and current sink are off. To meet the output voltage step size requirement of  $\pm 0.2$  V in Quick Charge 3.0 continuous mode, the mandatory value for the upper resistor in the output sensing voltage divider is  $R1 = 100.0 \text{ k}\Omega \pm 1\%$ . For a FEEDBACK pin reference voltage of 1.265 V for instance used by Power Integrations' Inno-Switch switcher IC the resulting value for  $R2 = 34.0 \text{ k}\Omega \pm 1\%$  to set the default output voltage to 5 V.

**Absolute Maximum Ratings<sup>3</sup>**

BYPASS Pin Voltage .....	-0.3 to 9 V	Storage Temperature .....	-65 °C to 150 °C
REFERENCE Pin Voltage .....	-0.3 to 9 V	Lead Temperature <sup>2</sup> .....	260 °C
FBD Pin Voltage .....	-0.3 to 9 V	Notes:	
D+/D- Pin Voltage .....	-0.3 to 5 V	1. Per USB BC 1.2 and HVDCP specifications.	
BYPASS Pin Current .....	25 mA	2. 1/16 in. from case for 5 seconds.	
D+/D- Pin Current .....	1 mA <sup>1</sup>	3. The Absolute Maximum Ratings specified may be applied one at a time without causing permanent damage to the product.	
Operating Junction Temperature.....	-40 °C to +150 °C	Exposure to Absolute Maximum Rating conditions for extended periods of time may affect product reliability.	
Operating Ambient Temperature.....	-40 °C to +105 °C		

Parameter	Symbol	Conditions	Min	Typ	Max	Units
		SOURCE = 0 V; T <sub>J</sub> = -20 °C to +85 °C (Unless Otherwise Specified)				
<b>Supply and Reference Function</b>						
BYPASS Pin Voltage	V <sub>BP</sub>	T <sub>J</sub> = +25 °C	3.1	4.3	6.3	V
Power-Up Reset Threshold Voltage	V <sub>BP(RESET)</sub>		TBD	2.7	TBD	V
BYPASS Pin Source Current	I <sub>BPSC</sub>	V <sub>BP</sub> = 4.3 V, R <sub>REF</sub> = 38.3 kΩ, T <sub>J</sub> = 25 °C			200	μA
BYPASS Pin Shunt Voltage	V <sub>BP(SHUNT)</sub>	I <sub>BP</sub> = 8 mA	5.7	6	6.3	V
REFERENCE Pin Voltage	V <sub>R</sub>	R <sub>REF</sub> = 38.3 kΩ	TBD	0.383	TBD	V
<b>Data Line D+ and D- Functions (HVDCP Interface)</b>						
Data Detect Voltage	V <sub>DAT(REF)</sub>		0.25	0.325	0.4	V
Output Voltage Selection Reference	V <sub>SEL(REF)</sub>		1.8	2	2.2	V
Data Lines Short-Circuit Delay	T <sub>DAT(SHORT)</sub>	V <sub>OUT</sub> ≥ 0.8 V		10	20	ms
D+ High Glitch Filter Time	T <sub>GLITCH(BC) DONE</sub>		1000		1500	ms
D- Low Glitch Filter Time	T <sub>GLITCH(DM) LOW</sub>		1			ms
Output Voltage Glitch Filter Time	T <sub>GLITCH(V) CHANGE</sub>		20	40	60	ms
Continuous Mode Glitch Filter Time	T <sub>GLITCH(CONT) CHANGE</sub>		TBD	150	TBD	μs
Continuous Mode Output Change Time	T <sub>V(CONT)CHANGE SINGLE</sub>				2	ms
D+ Leakage Resistance	R <sub>DAT(LKG)</sub>	V <sub>BP</sub> = 3.1-6.3 V, V <sub>D+</sub> = 0.5-3.6 V Switch N1 is Off	300	900	1500	kΩ
D- Pull-Down Resistance	R <sub>DM(DWN)</sub>		14.25	19.53	24.5	kΩ
Switch N1 On-Resistance	R <sub>DS(ON)N1</sub>	V <sub>BP</sub> = 4.3 V, V <sub>D+</sub> ≤ 3.6 V, I <sub>DRAIN</sub> = 200 μA		20	40	Ω
Data Line Capacitance	C <sub>DCP(PWR)</sub>	See Note A			1	nF
<b>FEEDBACK Pin Drive Functions</b>						
Toggle Up Current Source Step	ΔI <sub>T(UP)</sub>			2		μA
Toggle Down Current Source Step	ΔI <sub>T(DO)</sub>			2		μA

## NOTES:

A. Guaranteed by design. Not tested in production.

SO-8 (D Package)

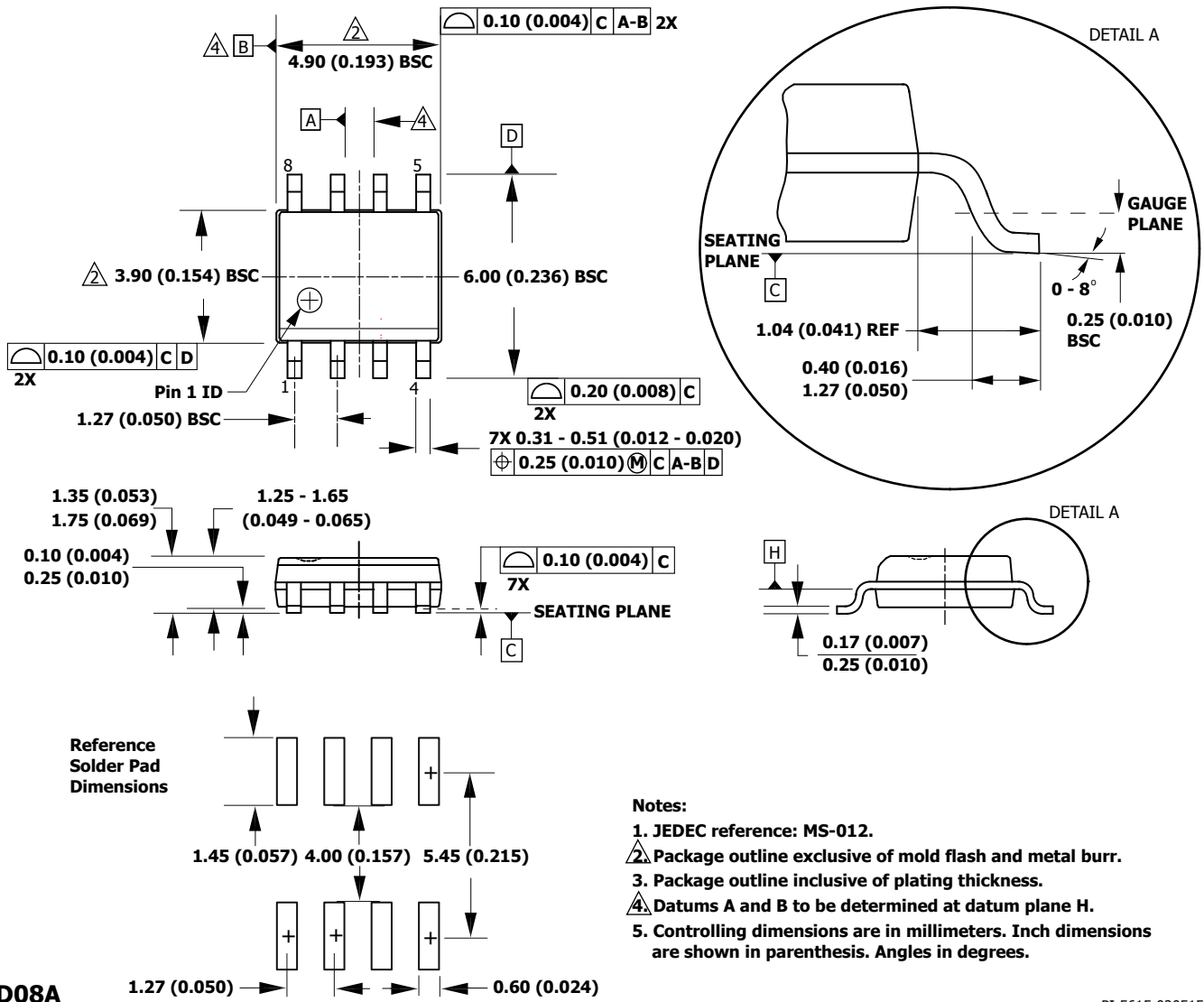

Part Ordering Information



---

Notes

Revision	Notes	Date
A	Preliminary	05/15

**For the latest updates, visit our website: [www.power.com](http://www.power.com)**

Power Integrations reserves the right to make changes to its products at any time to improve reliability or manufacturability. Power Integrations does not assume any liability arising from the use of any device or circuit described herein. POWER INTEGRATIONS MAKES NO WARRANTY HEREIN AND SPECIFICALLY DISCLAIMS ALL WARRANTIES INCLUDING, WITHOUT LIMITATION, THE IMPLIED WARRANTIES OF MERCHANTABILITY, FITNESS FOR A PARTICULAR PURPOSE, AND NON-INFRINGEMENT OF THIRD PARTY RIGHTS.

**Patent Information**

The products and applications illustrated herein (including transformer construction and circuits external to the products) may be covered by one or more U.S. and foreign patents, or potentially by pending U.S. and foreign patent applications assigned to Power Integrations. A complete list of Power Integrations patents may be found at [www.power.com](http://www.power.com). Power Integrations grants its customers a license under certain patent rights as set forth at <http://www.power.com/ip.htm>.

**Life Support Policy**

POWER INTEGRATIONS PRODUCTS ARE NOT AUTHORIZED FOR USE AS CRITICAL COMPONENTS IN LIFE SUPPORT DEVICES OR SYSTEMS WITHOUT THE EXPRESS WRITTEN APPROVAL OF THE PRESIDENT OF POWER INTEGRATIONS. As used herein:

1. A Life support device or system is one which, (i) is intended for surgical implant into the body, or (ii) supports or sustains life, and (iii) whose failure to perform, when properly used in accordance with instructions for use, can be reasonably expected to result in significant injury or death to the user.
2. A critical component is any component of a life support device or system whose failure to perform can be reasonably expected to cause the failure of the life support device or system, or to affect its safety or effectiveness.

The PI logo, TOPSwitch, TinySwitch, LinkSwitch, LYTSwitch, InnoSwitch, DPA-Switch, PeakSwitch, CAPZero, SENZero, LinkZero, HiperPFS, HiperTFS, HiperLCS, Qspeed, EcoSmart, Clampless, E-Shield, Filterfuse, FluxLink, StakFET, PI Expert and PI FACTS are trademarks of Power Integrations, Inc. Other trademarks are property of their respective companies. ©2015, Power Integrations, Inc.

**Power Integrations Worldwide Sales Support Locations**

**World Headquarters**

5245 Hellyer Avenue  
San Jose, CA 95138, USA.  
Main: +1-408-414-9200  
Customer Service:  
Phone: +1-408-414-9665  
Fax: +1-408-414-9765  
e-mail: [usasales@power.com](mailto:usasales@power.com)

**China (Shanghai)**

Rm 2410, Charity Plaza, No. 88  
North Caoxi Road  
Shanghai, PRC 200030  
Phone: +86-21-6354-6323  
Fax: +86-21-6354-6325  
e-mail: [chinasales@power.com](mailto:chinasales@power.com)

**China (Shenzhen)**

17/F, Hivac Building, No. 2, Keji Nan  
8th Road, Nanshan District,  
Shenzhen, China, 518057  
Phone: +86-755-8672-8689  
Fax: +86-755-8672-8690  
e-mail: [chinasales@power.com](mailto:chinasales@power.com)

**Germany**

Lindwurmstrasse 114  
80337 Munich  
Germany  
Phone: +49-895-527-39110  
Fax: +49-895-527-39200  
e-mail: [eurosales@power.com](mailto:eurosales@power.com)

**India**

#1, 14th Main Road  
Vasanthanagar  
Bangalore-560052 India  
Phone: +91-80-4113-8020  
Fax: +91-80-4113-8023  
e-mail: [indiasales@power.com](mailto:indiasales@power.com)

**Italy**

Via Milanese 20, 3rd. Fl.  
20099 Sesto San Giovanni (MI)  
Italy  
Phone: +39-024-550-8701  
Fax: +39-028-928-6009  
e-mail: [eurosales@power.com](mailto:eurosales@power.com)

**Japan**

Kosei Dai-3 Bldg.  
2-12-11, Shin-Yokohama,  
Kohoku-ku  
Yokohama-shi Kanagwan  
222-0033 Japan  
Phone: +81-45-471-1021  
Fax: +81-45-471-3717  
e-mail: [japansales@power.com](mailto:japansales@power.com)

**Korea**

RM 602, 6FL  
Korea City Air Terminal B/D, 159-6  
Samsung-Dong, Kangnam-Gu,  
Seoul, 135-728, Korea  
Phone: +82-2-2016-6610  
Fax: +82-2-2016-6630  
e-mail: [koreasales@power.com](mailto:koreasales@power.com)

**Singapore**

51 Newton Road  
#19-01/05 Goldhill Plaza  
Singapore, 308900  
Phone: +65-6358-2160  
Fax: +65-6358-2015  
e-mail: [singaporesales@power.com](mailto:singaporesales@power.com)

**Taiwan**

5F, No. 318, Nei Hu Rd., Sec. 1  
Nei Hu Dist.  
Taipei 11493, Taiwan R.O.C.  
Phone: +886-2-2659-4570  
Fax: +886-2-2659-4550  
e-mail: [taiwansales@power.com](mailto:taiwansales@power.com)

**UK**

First Floor, Unit 15, Meadway Court,  
Rutherford Close,  
Stevenage, Herts. SG1 2EF  
United Kingdom  
Phone: +44 (0) 1252-730-141  
Fax: +44 (0) 1252-727-689  
e-mail: [eurosales@power.com](mailto:eurosales@power.com)