

## LOW DROPOUT VOLTAGE REGULATOR(80mA)

### DESCRIPTION

The SC10XX series is a set of three-terminal low power voltage regulators implemented in CMOS technology. They are available with several fixed output voltages ranging from 1.5V--7.0V. CMOS technology ensures low voltage drop and low quiescent current.

Although designed primarily as fixed voltage regulators, these devices can be used with external components to obtain variable voltages and currents.

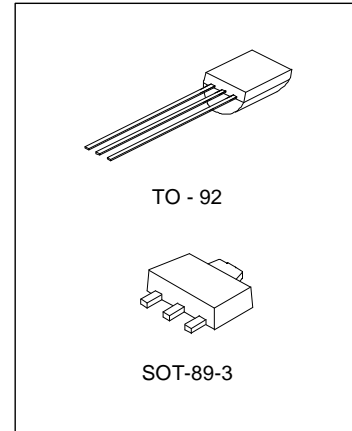

### FEATURES

- \* Low power consumption
- \* Low voltage drop
- \* Low temperature coefficient
- \* Wide operating voltage (12V Max.)
- \* TO-92 package
- \* SOT-89-3 package

### ORDERING INFORMATION

Device	Package
SC10XX	TO-92
SC10XXS	SOT-89-3

### APPLICATIONS

- \* Battery-powered equipment
- \* Communication equipment
- \* Audio/Video equipment

### SELECTION GUIDE

Part No.	Pin Assignment	Output Voltage	Tolerance
SC1015	B Type	1.5V	±2.4%. ±5%
SC1016	A Type		
SC1030	B Type	3.0V	±2.4%. ±5%
SC1031	A Type		
SC1033	B Type	3.3V	±2.4%. ±5%
SC1034	A Type		
SC1036	B Type	3.6V	±2.4%. ±5%
SC1037	A Type		
SC1038	B Type	3.8V	±2.4%. ±5%
SC1039	A Type		
SC1044	B Type	4.4V	±2.4%. ±5%
SC1045	A Type		
SC1050	B Type	5.0V	±2.4%. ±5%
SC1051	A Type		
SC1070	B Type	7.0V	±2.4%. ±5%
SC1071	A Type		

Note: For semi-custom parts, selectable regulated voltage range is from 2.4V to 9V in 0.1V increment.

**BLOCK DIAGRAM**

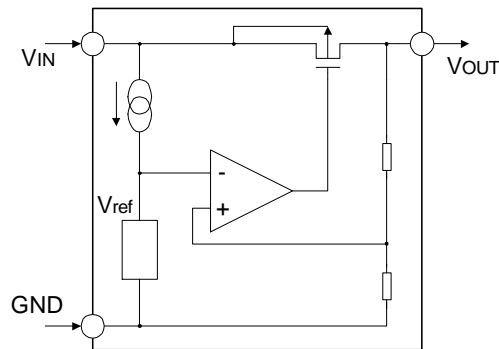

**ABSOLUTE MAXIMUM RATINGS**

Characteristic	Symbol	Value	Unit
Supply Voltage	VDC	0.3~15	V
Power Consumption	P <sub>D</sub>	250	m/W
Operating Temperature	T <sub>OPR</sub>	0~70	°C
Storage Temperature	T <sub>stg</sub>	-50~125	°C

Note: These are stress ratings only. Stresses exceeding the range specified under “Absolute Maximum Ratings” may cause substantial damage to the device. Functional operation of this device at other conditions beyond those listed in the specification is not implied and prolonged exposure to extreme conditions may affect device reliability.

**ELECTRICAL CHARACTERISTICS**

**SC10XX series (SC1015, SC1016, +1.5V output type) (T<sub>a</sub>=25°C)**

Symbol	Characteristics	Test Conditions		Min.	Typ.	Max.	Unit
		V <sub>IN</sub>	Conditions				
V <sub>OUT</sub>	Output Voltage Tolerance	3.5V	I <sub>OUT</sub> = 0.5mA	1.425	1.5	1.575	V
I <sub>OUT</sub>	Output Current	3.5V	--	7.0	--	--	mA
ΔV <sub>OUT</sub>	Load Regulation	3.5V	1mA ≤ I <sub>OUT</sub> ≤ 7mA	--	80	--	mV
V <sub>DIF</sub>	Voltage Drop	--	I <sub>OUT</sub> = 0.5mA	--	300	--	mV
I <sub>SS</sub>	Current Consumption	3.5V	No load	--	2.2	5.0	μA
$\frac{\Delta V_{OUT}}{\Delta V_{IN} \cdot V_{OUT}}$	Line Regulation	--	2.5V ≤ V <sub>IN</sub> ≤ 12V I <sub>OUT</sub> = 0.5mA	--	0.2	--	%/V
V <sub>IN</sub>	Input Voltage	--	--	--	--	12	V
$\frac{\Delta V_{OUT}}{\Delta T_a}$	Temperature Coefficient	3.5V	I <sub>OUT</sub> =0.5mA 0°C < T <sub>a</sub> < 70°C		±0.25		mV/°C

**SC10XX series (SC1030, SC1031, +3.0V output type) (Ta=25°C)**

Symbol	Characteristics	Test Conditions		Min.	Typ.	Max.	Unit
		V <sub>IN</sub>	Conditions				
V <sub>OUT</sub>	Output Voltage Tolerance	5V	I <sub>OUT</sub> = 10mA	2.85	3.0	3.15	V
I <sub>OUT</sub>	Output Current	5V	--	20	30	--	mA
ΔV <sub>OUT</sub>	Load Regulation	5V	1mA ≤ I <sub>OUT</sub> ≤ 20mA	--	60	100	mV
VDIF	Voltage Drop	--	I <sub>OUT</sub> = 1mA	--	60	--	mV
I <sub>SS</sub>	Current Consumption	5V	No load	--	2.5	6.0	μA
$\frac{\Delta V_{OUT}}{\Delta V_{IN} \cdot V_{OUT}}$	Line Regulation	--	4V ≤ V <sub>IN</sub> ≤ 12V I <sub>OUT</sub> = 1mA	--	0.2	--	%/V
V <sub>IN</sub>	Input Voltage	--	--	--	--	12	V
$\frac{\Delta V_{OUT}}{\Delta T_a}$	Temperature Coefficient	5V	I <sub>OUT</sub> =10mA 0°C < T <sub>a</sub> < 70°C		±0.45	--	mV/°C

**SC10XX series (SC1033, SC1034, +3.3V output type) (Ta=25°C)**

Symbol	Characteristics	Test Conditions		Min.	Typ.	Max.	Unit
		V <sub>IN</sub>	Conditions				
V <sub>OUT</sub>	Output Voltage Tolerance	5.5V	I <sub>OUT</sub> = 10mA	3.135	3.3	3.465	V
I <sub>OUT</sub>	Output Current	5.5V	--	20	30	--	mA
ΔV <sub>OUT</sub>	Load Regulation	5.5V	1mA ≤ I <sub>OUT</sub> ≤ 30mA	--	60	100	mV
VDIF	Voltage Drop	--	I <sub>OUT</sub> = 1mA	--	60	--	mV
I <sub>SS</sub>	Current Consumption	5.5V	No load	--	2.5	6.0	μA
$\frac{\Delta V_{OUT}}{\Delta V_{IN} \cdot V_{OUT}}$	Line Regulation	--	4.5V ≤ V <sub>IN</sub> ≤ 12V I <sub>OUT</sub> = 1mA	--	0.2	--	%/V
V <sub>IN</sub>	Input Voltage	--	--	--	--	12	V
$\frac{\Delta V_{OUT}}{\Delta T_a}$	Temperature Coefficient	5.5V	I <sub>OUT</sub> =10mA 0°C < T <sub>a</sub> < 70°C		±0.5	--	mV/°C

**SC10XX series (SC1036, SC1037, +3.6V output type) (Ta=25°C)**

Symbol	Characteristics	Test Conditions		Min.	Typ.	Max.	Unit
		V <sub>IN</sub>	Conditions				
V <sub>OUT</sub>	Output Voltage Tolerance	5.6V	I <sub>OUT</sub> = 10mA	3.42	3.6	3.78	V
I <sub>OUT</sub>	Output Current	5.6V	--	20	30	--	mA
ΔV <sub>OUT</sub>	Load Regulation	5.6V	1mA ≤ I <sub>OUT</sub> ≤ 30mA	--	60	100	mV
VDIF	Voltage Drop	--	I <sub>OUT</sub> = 1mA	--	60	--	mV
I <sub>SS</sub>	Current Consumption	5.6V	No load	--	3.0	7.0	μA
$\frac{\Delta V_{OUT}}{\Delta V_{IN} \cdot V_{OUT}}$	Line Regulation	--	4.6V ≤ V <sub>IN</sub> ≤ 12V I <sub>OUT</sub> = 1mA	--	0.2	--	%/V
V <sub>IN</sub>	Input Voltage	--	--	--	--	12	V
$\frac{\Delta V_{OUT}}{\Delta T_a}$	Temperature Coefficient	5.6V	I <sub>OUT</sub> =10mA 0°C < T <sub>a</sub> < 70°C		±0.6	--	mV/°C

**SC10XX series (SC1038, SC1039, +3.8V output type) (Ta=25°C)**

Symbol	Characteristics	Test Conditions		Min.	Typ.	Max.	Unit
		V <sub>IN</sub>	Conditions				
V <sub>OUT</sub>	Output Voltage Tolerance	5.8V	I <sub>OUT</sub> = 10mA	3.61	3.8	3.99	V
I <sub>OUT</sub>	Output Current	5.8V	--	20	30	--	mA
ΔV <sub>OUT</sub>	Load Regulation	5.8V	1mA ≤ I <sub>OUT</sub> ≤ 30mA	--	60	150	mV
V <sub>DIF</sub>	Voltage Drop	--	I <sub>OUT</sub> = 1mA	--	60	--	mV
I <sub>SS</sub>	Current Consumption	5.8V	No load	--	3.0	8.0	μA
$\frac{\Delta V_{OUT}}{\Delta V_{IN} \cdot V_{OUT}}$	Line Regulation	--	4.8V ≤ V <sub>IN</sub> ≤ 12V I <sub>OUT</sub> = 1mA	--	0.2	--	%/V
V <sub>IN</sub>	Input Voltage	--	--	--	--	12	V
$\frac{\Delta V_{OUT}}{\Delta T_a}$	Temperature Coefficient	5.8V	I <sub>OUT</sub> =10mA 0°C < T <sub>a</sub> < 70°C		±0.7	--	mV/°C

**SC10XX series (SC1044, SC1045, +4.4V output type) (Ta=25°C)**

Symbol	Characteristics	Test Conditions		Min.	Typ.	Max.	Unit
		V <sub>IN</sub>	Conditions				
V <sub>OUT</sub>	Output Voltage Tolerance	6.4V	I <sub>OUT</sub> = 10mA	4.18	4.4	4.62	V
I <sub>OUT</sub>	Output Current	6.4V	--	20	30	--	mA
ΔV <sub>OUT</sub>	Load Regulation	6.4V	1mA ≤ I <sub>OUT</sub> ≤ 30mA	--	60	100	mV
V <sub>DIF</sub>	Voltage Drop	--	I <sub>OUT</sub> = 1mA	--	60	--	mV
I <sub>SS</sub>	Current Consumption	6.4V	No load	--	3.0	7.5	μA
$\frac{\Delta V_{OUT}}{\Delta V_{IN} \cdot V_{OUT}}$	Line Regulation	--	5.4V ≤ V <sub>IN</sub> ≤ 12V I <sub>OUT</sub> = 1mA	--	0.2	--	%/V
V <sub>IN</sub>	Input Voltage	--	--	--	--	12	V
$\frac{\Delta V_{OUT}}{\Delta T_a}$	Temperature Coefficient	6.4V	I <sub>OUT</sub> =10mA 0°C < T <sub>a</sub> < 70°C		±0.7	--	mV/°C

**SC10XX series (SC1050, SC1051, +5.0V output type) (Ta=25°C)**

Symbol	Characteristics	Test Conditions		Min.	Typ.	Max.	Unit
		V <sub>IN</sub>	Conditions				
V <sub>OUT</sub>	Output Voltage Tolerance	7V	I <sub>OUT</sub> = 10mA	4.75	5.0	5.25	V
I <sub>OUT</sub>	Output Current	7V	--	20	30	--	mA
ΔV <sub>OUT</sub>	Load Regulation	7V	1mA ≤ I <sub>OUT</sub> ≤ 30mA	--	60	100	mV
V <sub>DIF</sub>	Voltage Drop	--	I <sub>OUT</sub> = 1mA	--	60	--	mV
I <sub>SS</sub>	Current Consumption	7V	No load	--	3.5	9.0	μA
$\frac{\Delta V_{OUT}}{\Delta V_{IN} \cdot V_{OUT}}$	Line Regulation	--	6V ≤ V <sub>IN</sub> ≤ 12V I <sub>OUT</sub> = 1mA	--	0.2	--	%/V
V <sub>IN</sub>	Input Voltage	--	--	--	--	12	V
$\frac{\Delta V_{OUT}}{\Delta T_a}$	Temperature Coefficient	7V	I <sub>OUT</sub> =10mA 0°C < T <sub>a</sub> < 70°C		±0.75	--	mV/°C

**SC10XX series (SC1070, SC1071, +7.0V output type) (Ta=25°C)**

Symbol	Characteristics	Test Conditions		Min.	Typ.	Max.	Unit
		VIN	Conditions				
VOUT	Output Voltage Tolerance	9V	IOUT = 10mA	6.65	7.0	7.35	V
IOUT	Output Current	9V	--	20	30	--	mA
ΔVOUT	Load Regulation	9V	1mA ≤ IOUT ≤ 30mA	--	60	100	mV
VDIF	Voltage Drop	--	IOUT = 1mA	--	60	--	mV
ISS	Current Consumption	9V	No load	--	5.0	12.5	μA
$\frac{\Delta V_{OUT}}{\Delta V_{IN} \cdot V_{OUT}}$	Line Regulation	--	8V ≤ VIN ≤ 12V IOUT = 1mA	--	0.2	--	%/V
VIN	Input Voltage	--	--	--	--	12	V
$\frac{\Delta V_{OUT}}{\Delta T_a}$	Temperature Coefficient	9V	IOUT=10mA 0°C < Ta < 70°C		±1.05	--	mV/°C

**PIN CONFIGURATION (TO-92)**

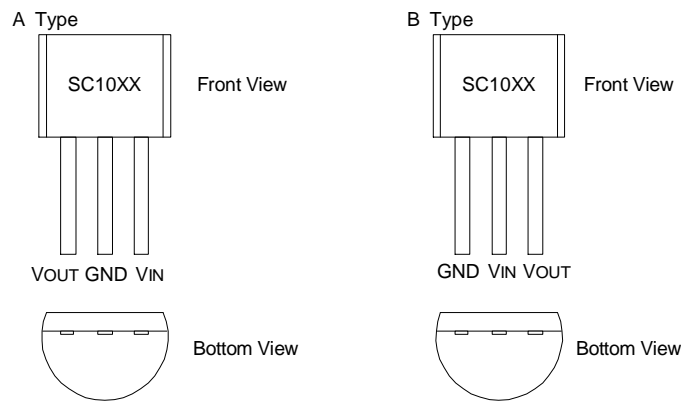

**PIN CONFIGURATION (SOT-89-3)**



**TYPICAL APPLICATION CIRCUIT**

The basic circuits of the SC10XX series

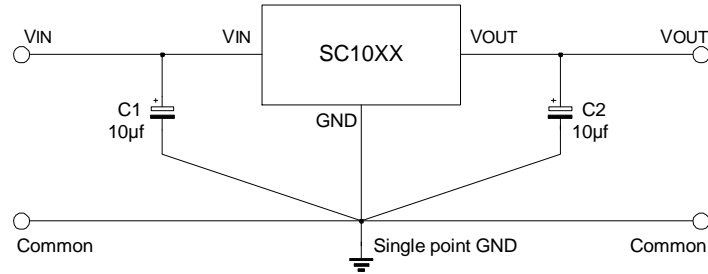

High output current positive voltage regulator

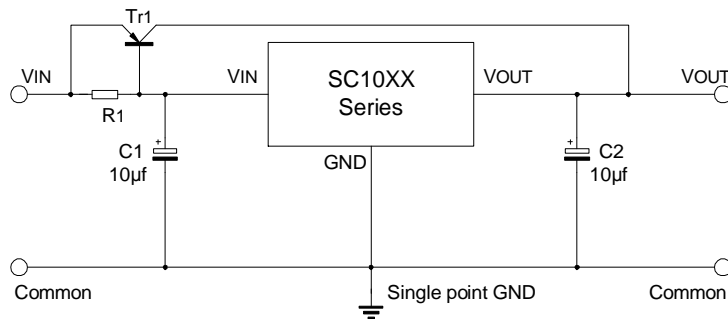

Short-Circuit protection for Tr1

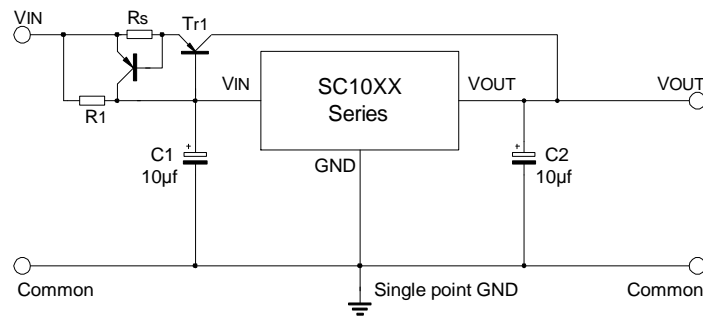

Circuit for increasing output voltage

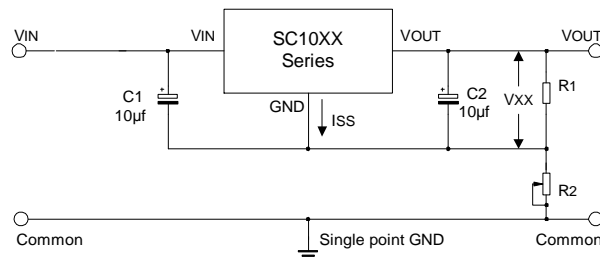

$$V_{OUT} = V_{XX} \cdot \left( 1 + \frac{R_2}{R_1} \right) + I_{SS} \cdot R_2$$

$$\approx V_{XX} \cdot \left( 1 + \frac{R_2}{R_1} \right)$$

Circuit for increasing output voltage

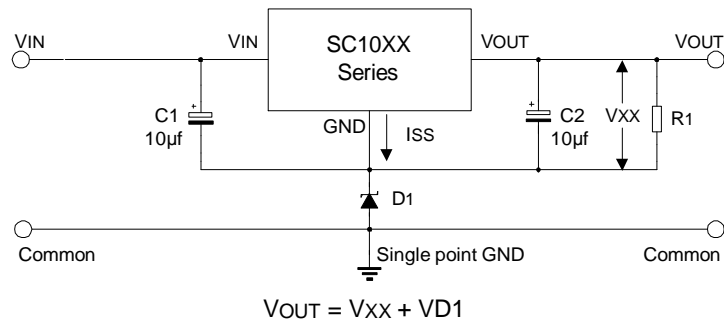

Constant current regulator

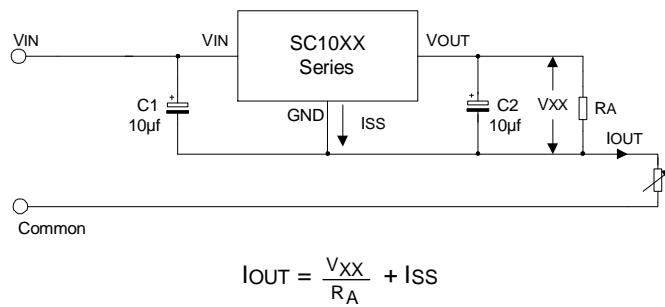

Dual supply

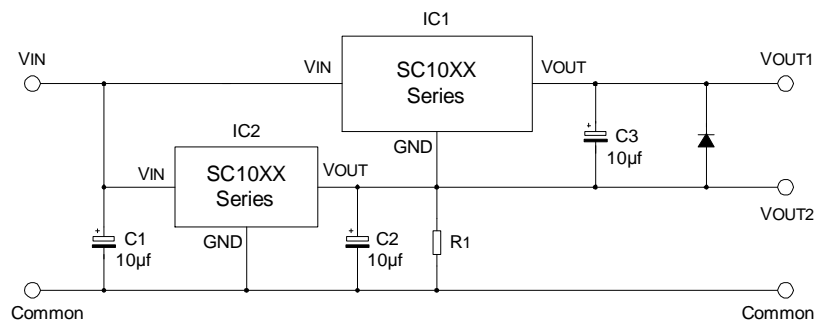

Note: The circuit and parameters are reference only, please set the parameters of the real application circuit based on the real test.

PACKAGE OUTLINE

TO-92

UNIT: mm

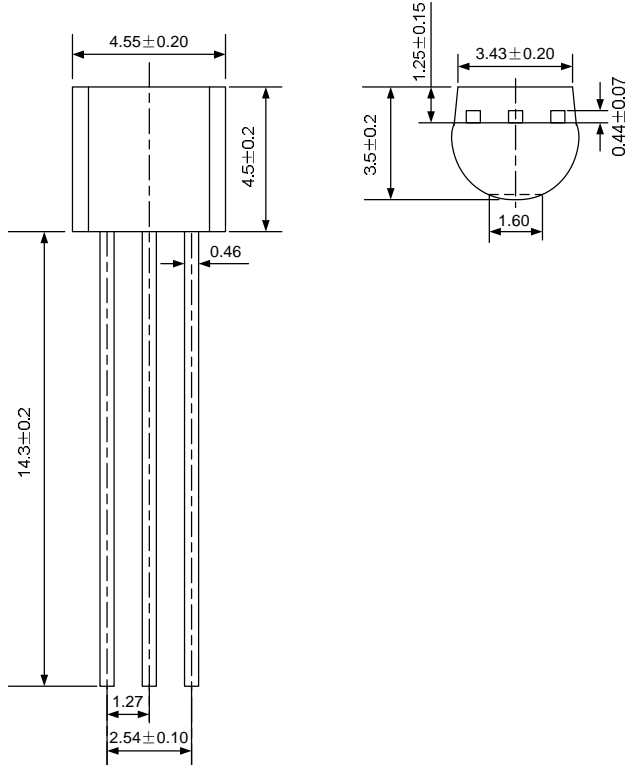

SOT-89-3

UNIT: mm

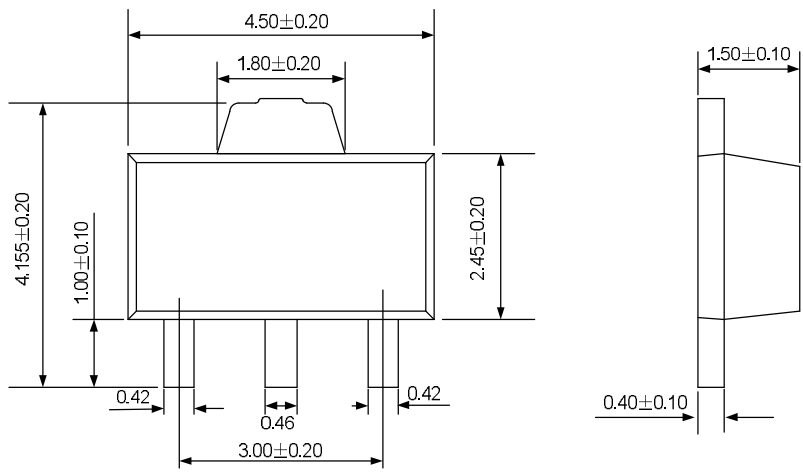





#### **HANDLING MOS DEVICES:**

Electrostatic charges can exist in many things. All of our MOS devices are internally protected against electrostatic discharge but they can be damaged if the following precautions are not taken:

- Persons at a work bench should be earthed via a wrist strap.
- Equipment cases should be earthed.
- All tools used during assembly, including soldering tools and solder baths, must be earthed.
- MOS devices should be packed for dispatch in antistatic/conductive containers.



Attachment

Revision History

Data	REV	Description	Page
2000.12.31	1.0	Original	
2004.05.08	1.1	Add the "SOT-89-3" package.	