

SC10A DAC Series – Power Module

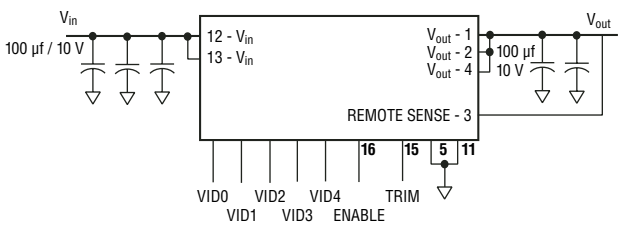

Product Schematic

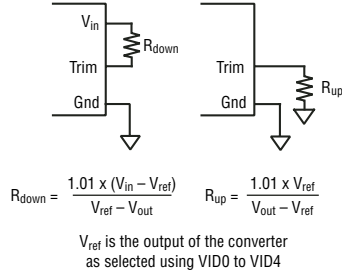

Temperature Derating

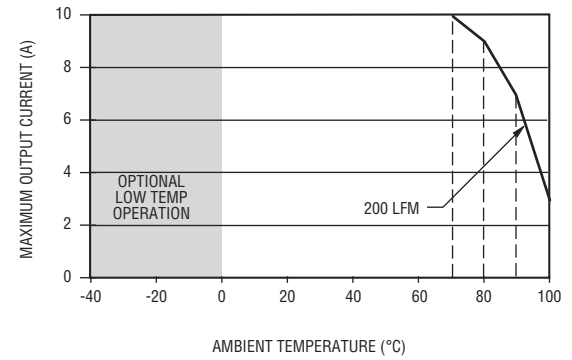

How to Order

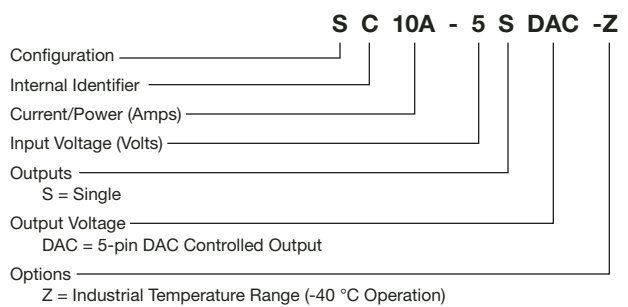

Reliable Electronic Solutions

Asia-Pacific: TEL +886- (0)2 25624117 • FAX +886- (0)2 25624116
 Europe: TEL +41-41 768 5555 • FAX +41-41 768 5510
 The Americas: TEL +1-951 781-5500 • FAX +1-951 781-5700
www.bourns.com