



SC1117(文件编号: S&CIC0539)

800mA Adjustable & Fixed Voltage LDO Linear Regulator

General description

The SC1117 is a low-dropout linear regulator that operates in the input voltage range from +2.5V to +7.0V and delivers 800mA output current.

The SC1117 is available in two types, fixed output voltage type or adjustable output voltage type. The fixed output voltage type is preset at an internally trimmed voltage 1.8V, 2.5V, or 3.3V. Other options 1.5V, 2.85V, 3.0V and 3.6V are available by special order only. The output voltage range of the adjustable type is from 1.25V to 5V.

The SC1117 consists of a 1.25V bandgap reference, an error amplifier, and a P-channel pass transistor. Other features include short-circuit protection and thermal shutdown protection. The SC1117 devices are available in SOT-223 and TO-252 packages.

Features

- Low dropout voltage 700mV at 800mA typ.
- Adjustable output voltage (SC1117-Cx) or fixed output voltage (SC1117-xxCx) preset at 1.8V, 2.5V, or 3.3V
- High output voltage accuracy
- Fixed output voltage: $\pm 35\text{mV}$
- Adjustable output voltage: $\pm 50\text{mV}$
- Small output capacitor
- Output current limit
- Thermal overload shutdown protection
- SOT-223 and TO-252 packages

Applications

- Active SCSI terminators
- High efficiency linear regulators
- Monitor microprocessors
- Low voltage micro-controllers
- Post regulator for switching power



SC1117(文件编号: S&CIC0539)

800mA Adjustable & Fixed Voltage LDO Linear Regulator

Ordering information

SC1117-XX X X

Package Pin Out
 G:SOT-223 1. IN 2. GND 3. OUT
 H:SOT-223 1. GND 2. IN 3. OUT
 J:SOT-223 1. GND 2. OUT 3. IN
 P:TO-252 1. IN 2. GND 3. OUT
 R:TO-252 1. GND 2. OUT 3. IN
 Note:For the adjustable voltage types,the GND pin is replaced with the ADJ pin

Temperature Range
 C:Commercial Standard
 P:Commercial Standard, Lead(Pb) Free and phosphorous(P) Free Package

Output Voltage
 (For fixed voltage types Inly. for adjustable voltage types,these two digits are eliminated.)
 15:1.5V 18:1.8V 25:2.5V
 29:2.85V 30:3.0V 33:3.3V
 36:3.6V
 Default: Adjustable Output

Note:The output voltages other than the preset values are available by order only.

Pin configurations

Part No.	Pin1	Pin2	Pin3
SC1117-XXXG	IN	GND/ADJ (TAP)	OUT
SC1117-XXXH	GND/ADJ	IN (TAP)	OUT
SC1117-XXXJ	GND/ADJ	OUT (TAP)	IN

Part No.	Pin1	Pin2	Pin3
SC1117-XXXP	IN	GND/ADJ (TAP)	OUT
SC1117-XXXR	GND/ADJ	OUT (TAP)	IN

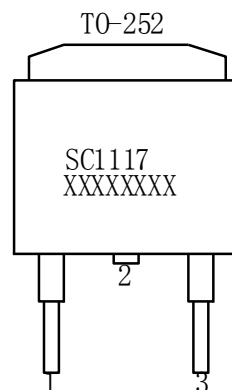
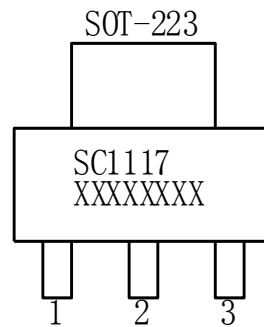



SC1117 (文件编号: S&CIC0539)

800mA Adjustable & Fixed Voltage LDO Linear Regulator

Package marking information

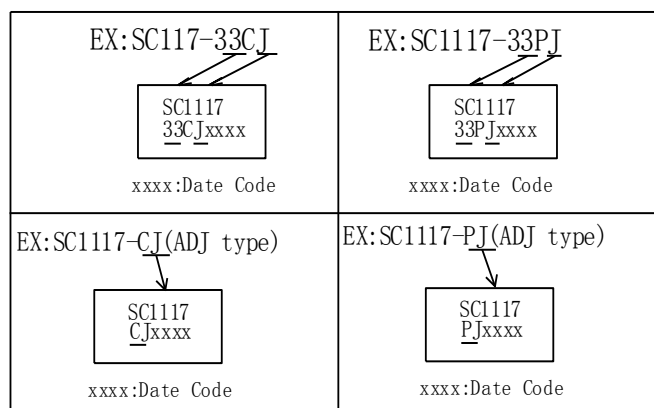

Pin description

Part No	Symbol	Description
SC1117-xxCG	GND/ADJ	Ground pin or adjust terminal pin
SC1117-xxCH	IN	Regulator input pin
SC1117-xxCJ	OUT	Regulator output pin
SC1117-xxCP		
SC1117-xxCR		

IN is the regulator input pin. Supply voltage can range from 2.5V to 7.0V. Bypass with a 10uF capacitor to GND.

OUT is the output voltage pin. Sources up to 800mA. Bypass with a 10uF capacitor to GND.

GND provides the reference for all voltages.

ADJ provides $V_{REF}=1.25V$ (TYP.) for adjustable output voltage.

Typical application circuit

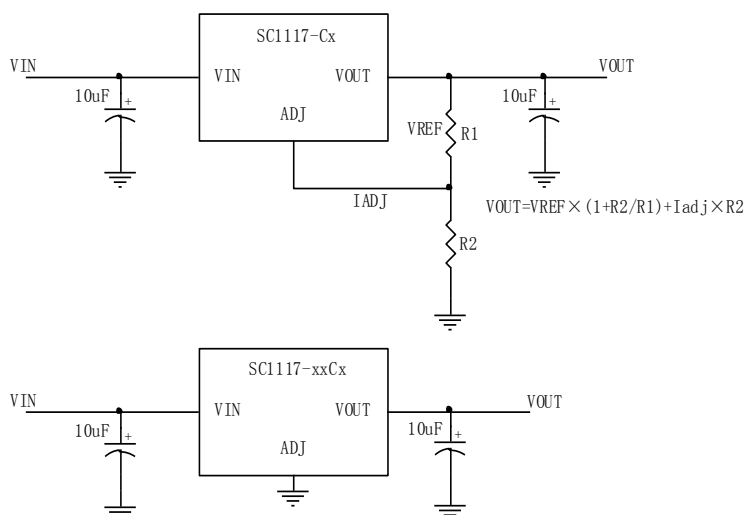



SC1117(文件编号: S&CIC0539)

800mA Adjustable & Fixed Voltage LDO Linear Regulator

Functional block diagrams

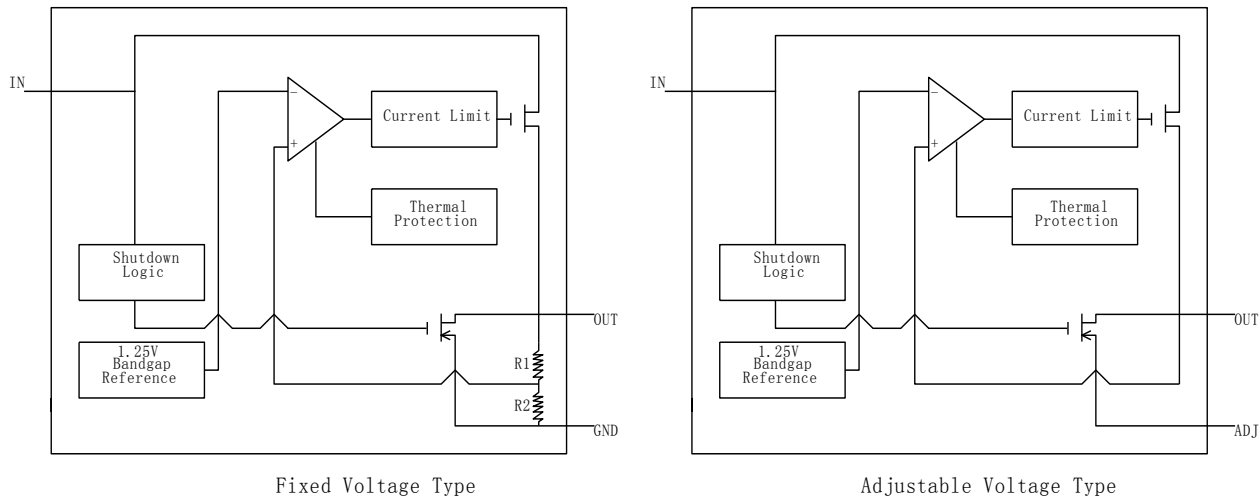

Absolute maximum ratings

Input voltage V_{IN} to GND-----	7V
Output current limit, $I_{(LIMIT)}$ -----	800mA
Continuous power dissipation-----	Internally limited
Junction temperature, T_J -----	+155°C
Storage temperature range, T_{STG} -----	-55°C to +150°C
Operating junction temperature range-----	-40°C to +125°C
Lead temperature (soldering, 10sec)-----	260°C

* Stresses beyond those listed under “absolute maximum ratings” may cause permanent damage to the device. These are stress ratings only, and function operation of the device at these or any other conditions beyond those indicated under “recommended operating conditions” is not implied. Exposure to absolute-maximum-rated conditions for extended periods may affect device reliability.



SC1117(文件编号: S&CIC0539)

800mA Adjustable & Fixed Voltage LDO Linear Regulator

Electrical characteristics($C_{IN}=10\mu F$, $C_{OUT}=10\mu F$, $T_A=25^\circ C$, unless otherwise noted.)

Symbol	Parameter	Test Conditions		Min	Typ	Max	Unit
V_{IN}	Input voltage			2.5		7.0	V
V_{OUT}	Output voltage	Fixed voltage type $V_{IN}=V_{OUT}+1.0V$, $I_{OUT}=1mA$		$V_{OUT}-0.035$	V_{OUT}	$V_{OUT}+0.035$	V
		Adjustable voltage type $V_{IN}=V_{OUT}+1.2V$, $I_{OUT}=1mA$		1.2	1.25	1.3	V
ΔV_{OUT}	Output voltage accuracy	$V_{IN}>V_{OUT}+1.0V$, $V_{IN}\leq 7V$ (fixed voltage type)		-35		+35	mV
		$V_{IN}>V_{OUT}+1.2V$, $V_{IN}\leq 7V$ (adjustable voltage type)		-50		+50	mV
I_{MAX}	Maximum output current			1.0			A
I_{LIMIT}	Current limit					1.3	A
I_{SC}	Short-circuit current	$V_{OUT}=0V$	$V_{IN}>V_{OUT}+1.0V$, (fixed voltage type)		650	760	mA
			$V_{IN}>V_{OUT}+1.2V$, (adjustable voltage type)				
I_Q	Ground pin current	$I_{LOAD}=0mA$ to 1A, $V_{IN}=V_{OUT}+1.0V$			65	90	μA
I_{ADJ}	ADJ pin current	$I_{LOAD}=0mA$ to 1A, $V_{IN}=V_{OUT}+1.2V$			65	90	μA
V_{DROP}	Dropout voltage (fixed output voltage version)	$I_{OUT}=100mA$			60	100	mV
		$I_{OUT}=500mA$			300	500	mV
		$I_{OUT}=800mA$			700	1000	mV
ΔV_{LINE}	Line regulation	$V_{OUT}+1.0V<V_{IN}<7V$, $I_{LOAD}=1mA$ (fixed voltage type)			0.2	0.3	%/V
		$V_{OUT}+1.2V<V_{IN}<7V$, $I_{LOAD}=1mA$ (adjustable voltage type)			0.2	0.3	%/V
ΔV_{LOAD}	Load regulation	$I_{OUT}=0mA$ to 800mA (fixed voltage type)			0.02	0.03	%/mA
		$I_{OUT}=0mA$ to 800mA (adjustable voltage type)			0.1	0.15	%/mA
EN	Output noise	F=1Hz to 10KHz, $C_{OUT}=10\mu F$			80		U/ V_{RMS}
PSRR	Ripple rejection	F=10KHz, $C_{OUT}=10\mu F$			75		dB
T_{SD}	Thermal shutdown Temperature				155		$^\circ C$
T_{HYS}	Thermal shutdown Hysteresis				20		$^\circ C$
θ_{JA}	Thermal resistance(NO Heat-sink, No air flow)	SOT-223			155		$^\circ C/W$
		TO-252			90		$^\circ C/W$



SC1117(文件编号: S&CIC0539)

800mA Adjustable & Fixed Voltage LDO Linear Regulator

Typical operating characteristics($C_{IN}=10\mu F$, $C_{OUT}=10\mu F$, $T_A=+25^\circ C$, unless otherwise noted.)

OUTPUT VOLTAGE vs. INPUT VOLTAGE

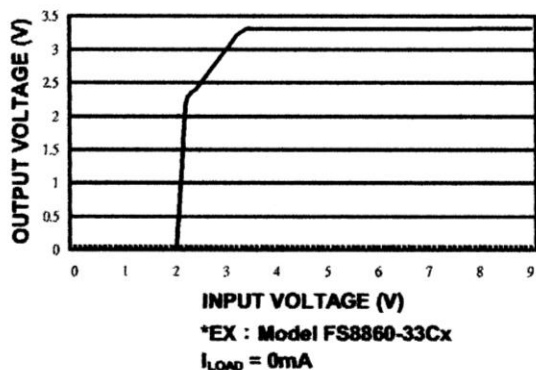

GROUND PIN CURRENT vs. AMBIENT TEMPERATURE

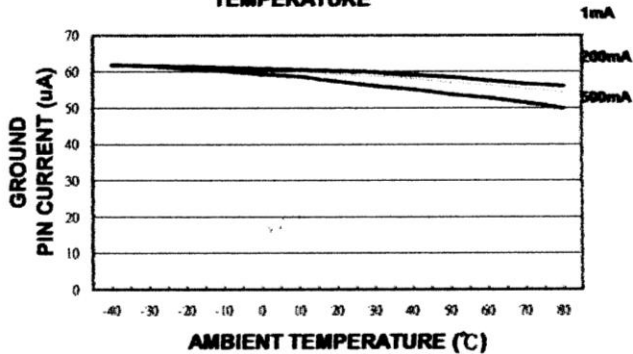

DROPOUT VOLTAGE vs. LOAD CURRENT

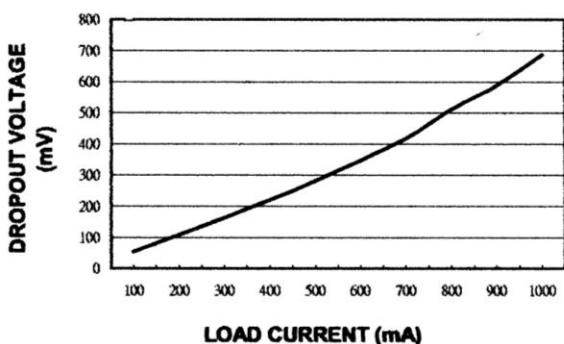

Ron vs. LOAD CURRENT

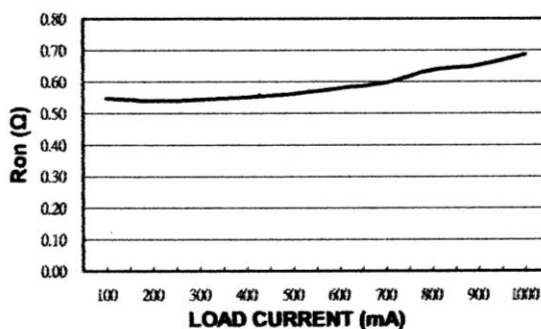

POWER SUPPLY REJECTION RATIO vs. FREQUENCY

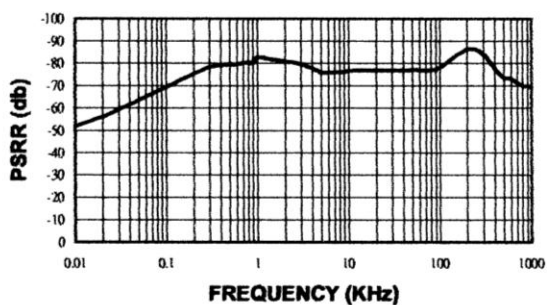

GROUND PIN CURRENT vs. LOAD CURRENT

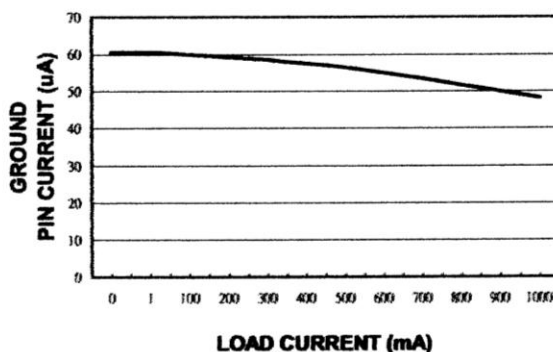



SC1117 (文件编号: S&CIC0539)

800mA Adjustable & Fixed Voltage LDO Linear Regulator

OUTPUT VOLTAGE vs. AMBIENT TEMPERATURE

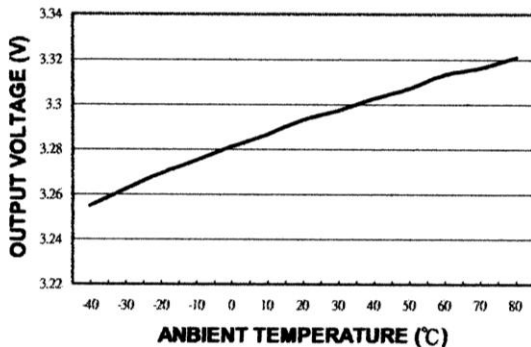

ADJ PIN CURRENT vs. INPUT VOLTAGE

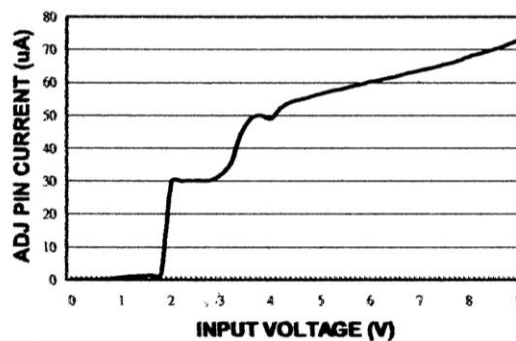

ADJ PIN CURRENT vs. LOAD CURRENT

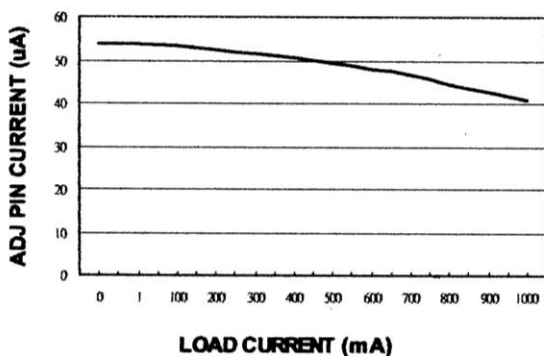

ADJ PIN CURRENT vs. AMBIENT TEMPERATURE

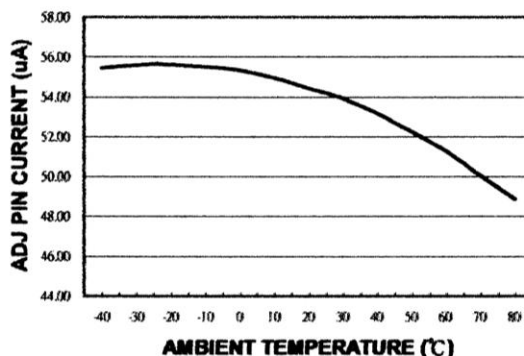

Vref vs. AMBIENT TEMPERATURE

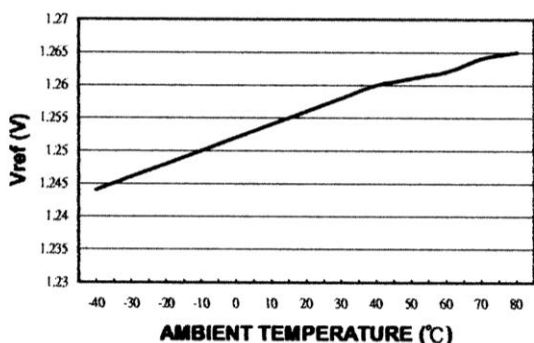

Output Noise DC to 1MHz

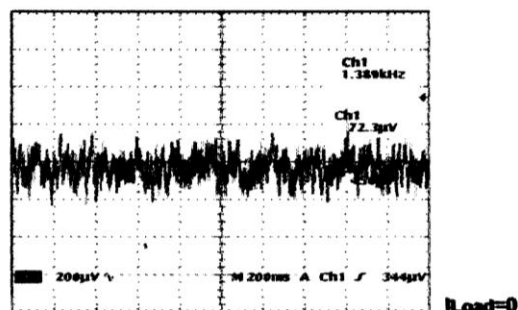



SC1117 (文件编号: S&CIC0539)

800mA Adjustable & Fixed Voltage LDO Linear Regulator

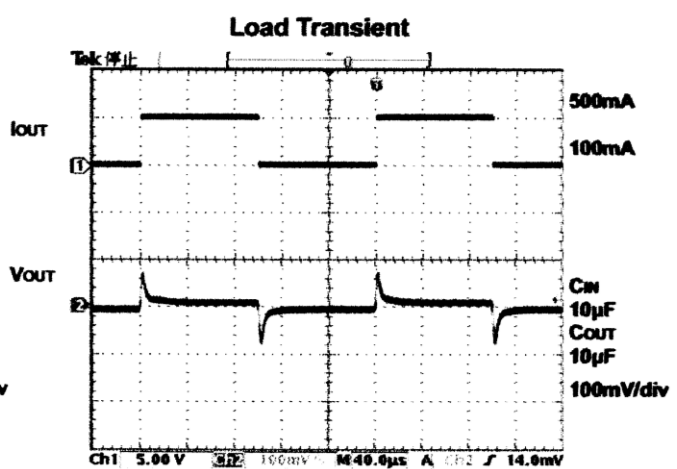
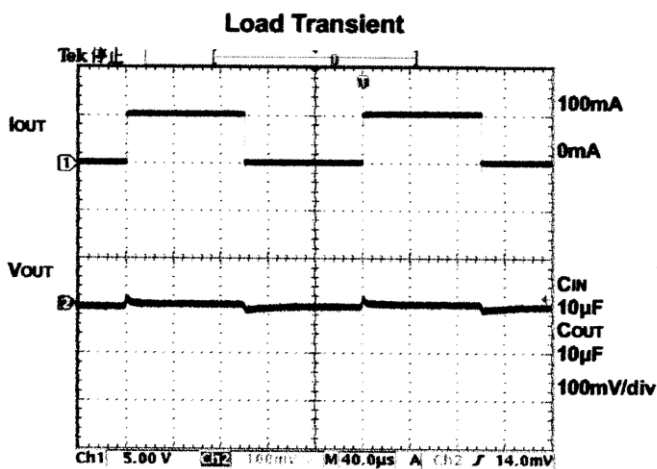
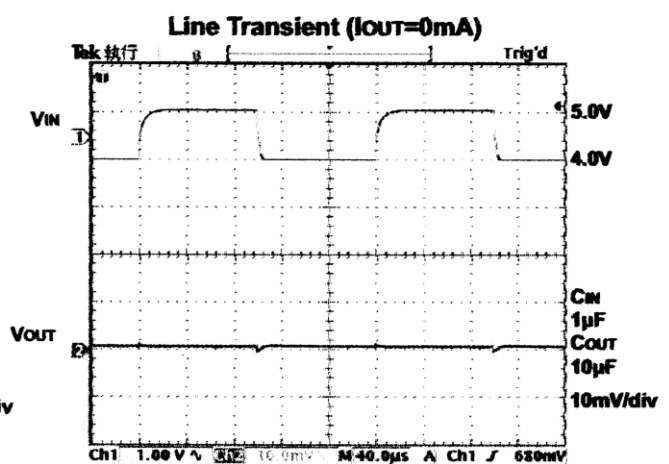
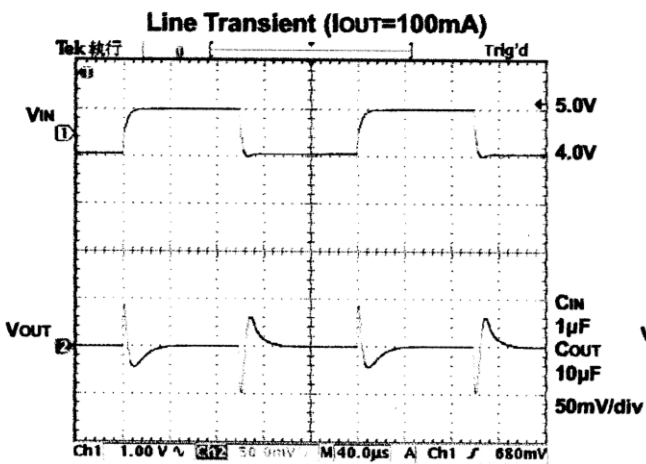
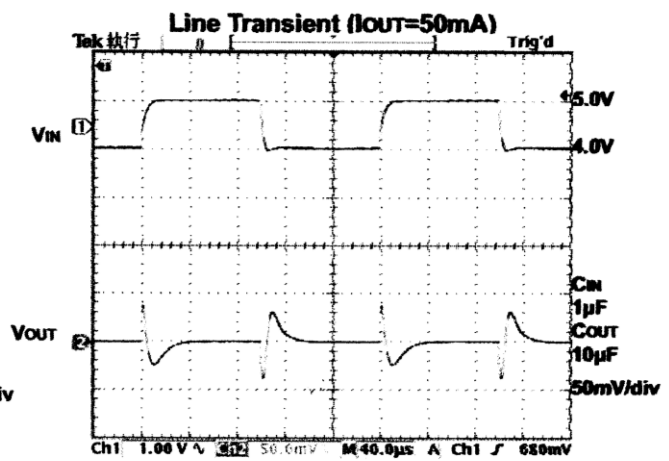
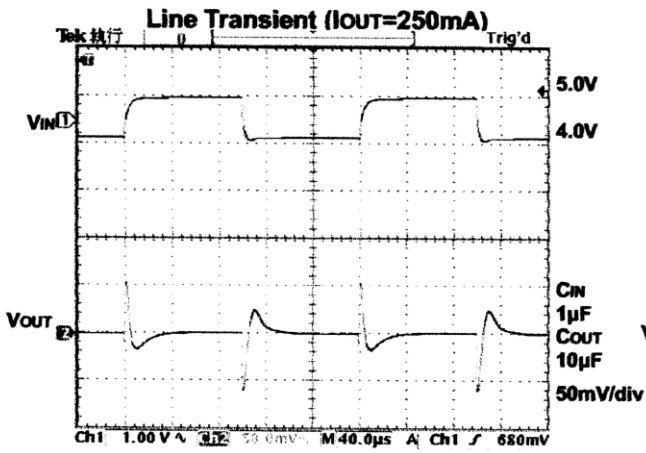



SC1117(文件编号: S&CIC0539)

800mA Adjustable & Fixed Voltage LDO Linear Regulator

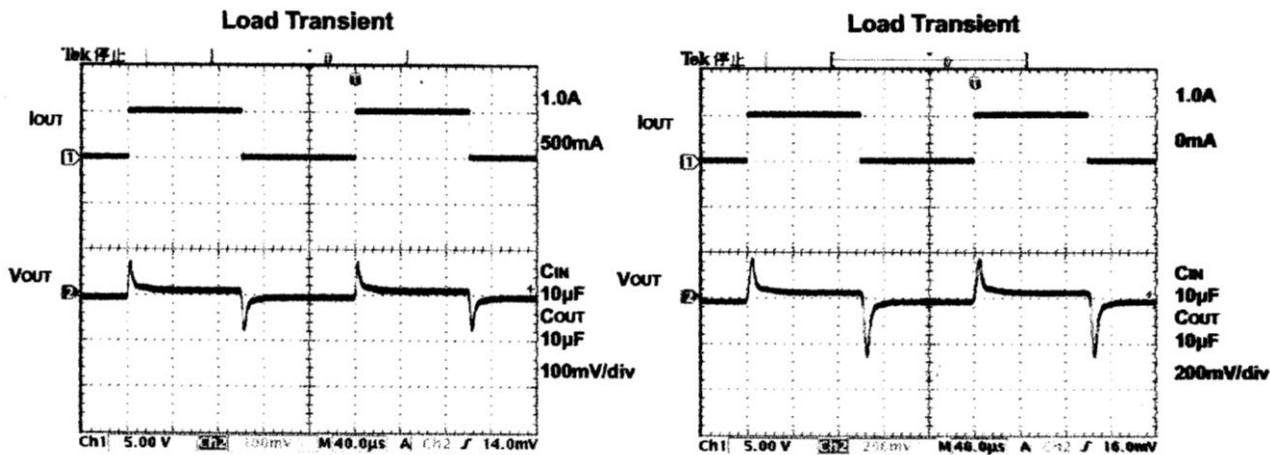

Detail description

The SC1117 is a low-dropout linear regulator. The device provides preset 1.8V, 2.5V and 3.3V output voltages for output current up to 800mA. adjustable output voltage and other mask options for special output voltages are also available. As illustrated in function block diagram, it consists of a 1.25V bandgap reference, an error amplifier, a P-channel pass transistor and an internal feedback voltage divider (fixed voltage types).

The 1.25V bandgap reference is connected to the error amplifier, which compares this reference with the feedback voltage and amplifies the voltage difference. If the feedback voltage is lower than the reference voltage, the pass-transistor gate is pulled lower, which allows more current to pass to the output pin and increases the output voltage. If the feedback voltage is too high, the pass-transistor gate is pulled up to decrease the output voltage.

The output voltage is feed back through an internal resistive divider (or external resistive divider for adjustable output voltage type) connected to OUT pin. Additional blocks include an output current limiter, thermal sensor, and shutdown logic.

Internal P-channel pass transistor

The SC1117 features a P-channel MOSFET pass transistor. Unlike similar designs using PNP pass transistors, P-channel MOSEFTS require no base drive, which reduces ground pin current. PNP-based regulators also waste considerable current in dropout when the pass transistor saturates, and use high base-drive currents under large loads. The SC1117 does not suffer from these problems and consumes only 65µA(Typ) of fround pin current under heavy loads as well as in dropout conditions.

Output voltage selection

For fixed voltage type of SC1117, the output voltage is preset at an internally trimmed voltage. The first two digits of part number suffix identify the output voltage (see [Ordering Information](#)). For example, the SC1117-33CJ has a preset 3.3V output voltage.

For adjustable voltage type of SC1117, the output voltage is set by comparing the feedback voltage at adjust terminal to the internal bandgap reference voltage. The reference voltage V_{REF} is 1.25V. The output voltage is given by the equation:

$$V_{OUT} = V_{REF} * (1 + R2/R1) + I_{ADJ} * R2$$

(see [Typical Application Schematic](#))

Current limit

The SC1117 also includes a fold back current limiter. It monitors and controls the pass transistor's gate voltage, estimates the output current, and limits the output current within 800mA.

Thermal overload protection limits total power dissipation is the SC1117. When the junction temperature exceeds $T_J = +155^\circ\text{C}$,



SC1117(文件编号: S&CIC0539)

800mA Adjustable & Fixed Voltage LDO Linear Regulator

a thermal sensor turns off the pass transistor, allowing the IC to cool down. The thermal sensor turns the pass transistor on again after the junction temperature cools down by 20°C, resulting in a pulsed output during continuous thermal overload conditions.

Operating region and power dissipation

Maximum power dissipation of the SC1117 depends on the thermal resistance of the case and circuit board, the temperature difference between the die junction and ambient air, and the rate of airflow. The power dissipation across the devices is $P=I_{OUT} \times (V_{IN}-V_{OUT})$. The resulting maximum power dissipation is:

$$P_{MAX}=(T_J-T_A)/(\theta_{JC} + \theta_{CA}) = (T_J-T_A)/ \theta_{JA}$$

Where (T_J-T_A) is the temperature difference between the SC1117 die junction and the surrounding air, θ_{JC} is the thermal resistance of the package chosen, and θ_{CA} is the thermal resistance through the printed circuit board, copper traces and other materials to the surrounding air. For better heat-sinking, the copper area should be equally shared between the IN, OUT, and GND pins.

If the SC1117 uses a SOT-223 package and this package is mounted on a double sided printed circuit board with two square inches of copper allocated for “heat spreading”, the resulting θ_{JA} is 80°C/W.

Based on the maximum operating junction temperature 125°C with an ambient of 25°C, the maximum power dissipation will be:

$$P_{MAX}=(T_J-T_A)/(\theta_{JC} + \theta_{CA}) = (125-25)/80=1.25W$$

Thermal characteristics were measured using a double-sided board with 1” × 2” square inches of copper area connected to the GND pin for “heat spreading”.

Input-output voltage

A regulator’s minimum input-output voltage differential, or dropout voltage, determines the lowest usable supply voltage. In battery-powered systems, this will determine the useful end-of-life battery voltage. The SC1117 uses a P-channel MOSEFT pass transistor, its dropout voltage is a function of drain-to-source on-resistance ($R_{DS(ON)}$) multiplied by the output current.

$$V_{DROPOUT}=V_{IN}-V_{OUT}=R_{DS(ON)} \times I_{OUT}$$



SC1117 (文件编号: S&CIC0539)

800mA Adjustable & Fixed Voltage LDO Linear Regulator

Package outline

SOT-223

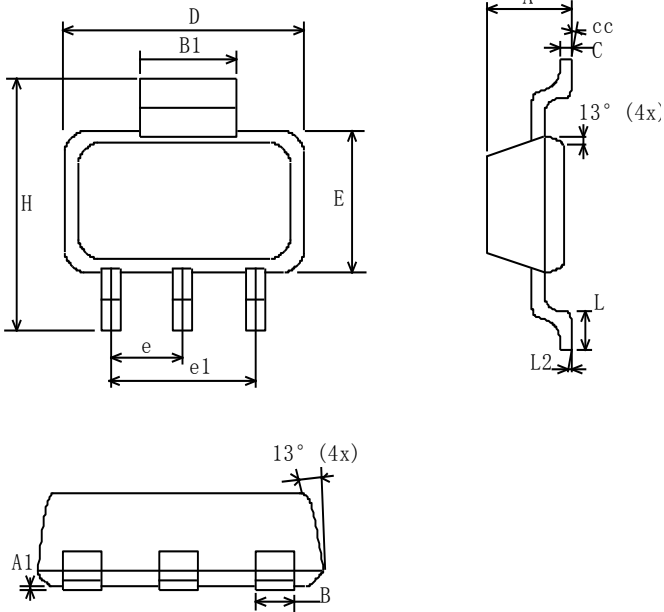

SYMBDLS	MILLIMETERS		DNCHES	
	MIN	MAX	MIN	MAX
A	1.55	1.90	0.061	0.071
A1	0.02	0.12	0.0008	0.0047
B	0.60	0.80	0.024	0.031
B1	2.90	3.10	0.114	0.122
C	0.24	0.32	0.009	0.013
D	6.20	6.70	0.248	0.264
E	3.30	3.70	0.120	0.146
e	2.30 BSC		0.090 BSC	
e1	4.60 BSC		0.181 BSC	
H	6.70	7.30	0.264	0.287
L	0.90 MIN		0.026 MIN	
L2	0.06 BSC		0.0024 BSC	
CC	0°	10°	0°	10°

TO-252

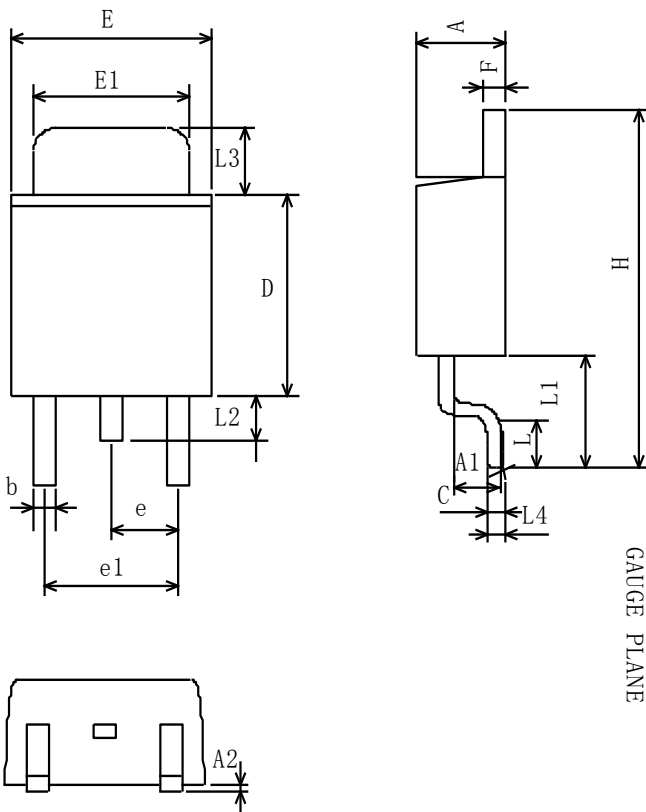

Symbol	MILLIMETERS		DNCHES	
	MIN	MAX	MIN	MAX
A	2.19	2.38	0.086	0.094
A1	0.99	1.27	0.035	0.050
A2	0.00	0.13	0.00	0.005
b	0.51	0.99	0.02	0.035
c	0.48	0.58	0.18	0.023
D	5.97	6.22	0.235	0.245
E	6.36	6.73	0.250	0.265
E1	5.21	5.48	0.205	0.215
e	2.28 BSC		0.090 BSC	
e1	3.98	5.16	0.156	0.204
F	0.48	0.58	0.018	0.023
L	1.40	1.78	0.055	0.070
L1	2.67(REF)		0.105(REF)	
L2	0.64	1.02	0.025	0.040
L3	1.52	2.03	0.030	0.050
L4	0.51 BSC		0.020BSC	
H	9.40	10.4	0.370	0.410
Q	0°	8°	0°	8°