

### POWER MANAGEMENT

#### Description

The SC1405B is a Dual-MOSFET Driver with an internal Overlap Protection Circuit to prevent shoot-through. Each driver is capable of driving a 3000pF load in 15ns rise/fall time and has ULTRA-LOW propagation delay from input transition to the gate of the power FET's. Adaptive Overlap Protection circuit ensures that the synchronous FET does not turn on until the top FET source has reached a voltage low enough to prevent shoot-through. The delay between the bottom gate going low to the top gate transitioning high is externally programmable via a capacitor to minimize dead time. The bottom FET may be disabled at light loads by keeping S\_MOD low to trigger asynchronous operation, thus saving the bottom FET's gate drive current and inductor ripple current. An internal voltage reference allows threshold adjustment for an Output Over-Voltage protection circuitry, independent of the PWM controller.

Under-Voltage-Lock-Out circuit is included to guarantee that both driver outputs are off when Vcc is less than or equal to 4.4V (typ) at supply ramp up (4.35V at supply ramp down). A CMOS output provides status indication of the 5V supply. A low enable input places the IC in stand-by mode, reducing supply current to less than 10µA. SC1405B is offered in a high pitch (.025" lead spacing) TSSOP package.

#### Features

- ◆ Fast rise and fall times (15ns with 3000pf load)
- ◆ **14ns max. Propagation delay (BG going low)**
- ◆ Adaptive and programmable shoot-through protection
- ◆ Wide input voltage range (4.5-25V)
- ◆ Power saving asynchronous mode control
- ◆ Output overvoltage protection/overtemp shutdown
- ◆ Under-Voltage lock-out and power ready signal
- ◆ Less than 10µA stand-by current (EN=low)
- ◆ Improved drive version of SC1405TS
- ◆ High frequency (to 1.2MHz) operation allows use of small inductors and low cost capacitors in place of electrolytics

#### Applications

- ◆ High Density/Fast transient microprocessor power supplies
- ◆ Motor Drives/Class-D amps
- ◆ High efficiency portable computers

#### Typical Application Circuit

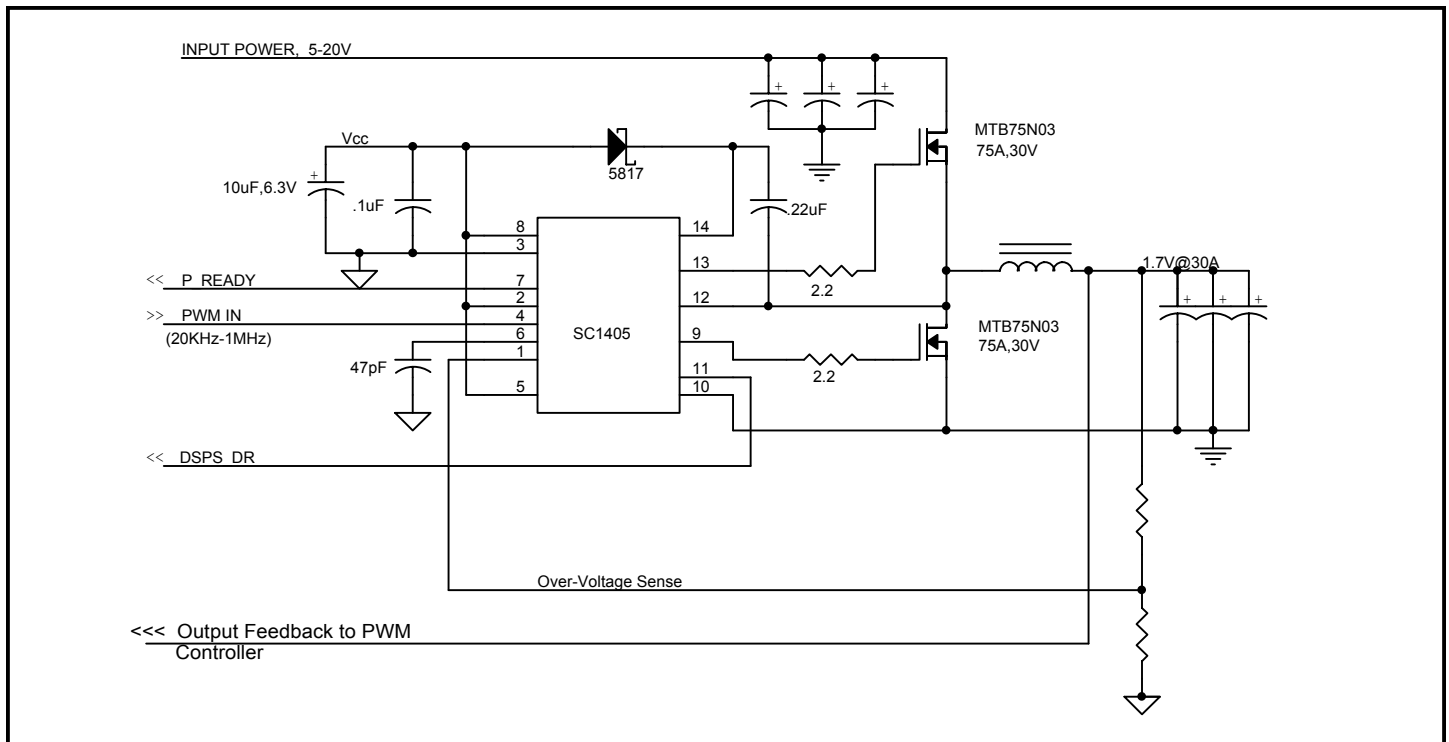

**POWER MANAGEMENT**
**Absolute Maximum Ratings**

Parameter	Symbol	Conditions	Maximum	Units
V <sub>CC</sub> Supply Voltage	V <sub>MAXSV</sub>		7	V
BST to PGND	VMAX <sub>BST-PGND</sub>		30	V
BST to DRN	VMAX <sub>BST-DRN</sub>		8	V
DRN to PGND	VMAX <sub>DRN-PGN</sub>		-2 to 25	V
DRN to PGND Pulse	VMAX <sub>PULSE</sub>	t <sub>PULSE</sub> < 100ns	-5 to 25	V
OVP_S to PGND	VMAX <sub>OVP SPGND</sub>		10	V
Input Pin	CO		-0.3 to 8.3	V
Continuous Power Dissipation	Pd	T <sub>AMB</sub> = 25°C, T <sub>J</sub> = 125°C T <sub>CASE</sub> = 25°C, T <sub>J</sub> = 125°C	0.66 2.56	W
Thermal Impedance Junction to Case	θ <sub>JC</sub>		40	°C/W
Thermal Impedance Junction to Ambient	θ <sub>JA</sub>		150	°C/W
Operating Temperature Range	T <sub>J</sub>		0 to +125	°C
Storage Temperature Range	T <sub>STG</sub>		-65 to +150	°C
Lead Temperature (Soldering) 10 Sec.	T <sub>LEAD</sub>		300	°C

**NOTE:**

(1) Specification refers to application circuit in Figure 1.

**Electrical Characteristics - DC Operating Specifications**

Unless specified: -0 < θ<sub>J</sub> < 125°C; V<sub>CC</sub> = 6V; 4V < V<sub>BST</sub> < 26V

Parameter	Symbol	Conditions	Min	Typ	Max	Units
<b>Power Supply</b>						
Supply Voltage	V <sub>CC</sub>		4.15	5	6.0	V
Quiescent Current	I <sub>q_stby</sub>	EN = 0V			10	µA
Quiescent Current, operating	I <sub>q_op</sub>	V <sub>CC</sub> = 5V, CO = 0V		1		mA
<b>PRDY</b>						
High Level Output Voltage	V <sub>OH</sub>	V <sub>CC</sub> = 4.6V, Iload = 10mA	4.5	4.55		V
Low Level Output Voltage	V <sub>OL</sub>	V <sub>CC</sub> < UVLO threshold, Iload = 10µA		0.1	0.2	V
Sink Current	I <sub>O_SINK</sub>	VPRDY = 0.4V	5	10		mA

**POWER MANAGEMENT**
**Electrical Characteristics - DC Operating Specifications**

Parameter	Symbol	Conditions	Min	Typ	Max	Units
<b>DSPS_DR</b>						
High Level Output Voltage	$V_{OH}$	$V_{CC} = 4.6V$ , $Cl_{oad} = 100pF$	4.15			V
Low Level Output Voltage	$V_{OL}$	$V_{CC} = 4.6V$ , $Cl_{oad} = 100pF$			0.05	V
<b>Under Voltage Lockout</b>						
Start Threshold	$V_{START}$		4.2	4.4	4.6	V
Hysteresis	$V_{hys_{UVLO}}$			0.05		V
Logic Active Threshold	$V_{ACT}$				1.5	V
<b>Overvoltage Protection</b>						
Trip Threshold	$V_{TRIP}$		1.145	1.2	1.255	V
Hysteresis	$V_{hys_{OVP}}$			0.8		V
<b>S_MOD</b>						
High Level Input Voltage	$V_{IH}$		2.0			V
Low Level Input Voltage	$V_{IL}$				0.8	V
<b>Enable</b>						
High Level Input Voltage	$V_{IH}$		2.0			V
Low Level Input Voltage	$V_{IL}$				0.8	V
<b>CO</b>						
High Level Input Voltage	$V_{IH}$		2.0			V
Low Level Input Voltage	$V_{IL}$				0.8	V
<b>Thermal Shutdown</b>						
Over Temperature Trip Point	$T_{OTP}$			165		°C
Hysteresis	$T_{HYST}$			10		°C
<b>High-Side Driver</b>						
Peak Output Current	$I_{PKH}$			3		A
Output Resistance	$R_{src_{TG}}$ $R_{sink_{TG}}$	duty cycle < 2%, $tpw < 100\mu s$ , $T_J = 125^\circ C$ , $V_{BST} - V_{DRN} = 4.5V$ , $V_{TG} = 4.0V (src) + V_{DRN}$ or $VTG = 0.5V (sink) + V_{DRN}$		1 .7		$\Omega$
<b>Low-Side Drive</b>						
Peak Output Current	$I_{PKL}$			3		A
Output Resistance	$R_{src_{BG}}$ $R_{sink_{BG}}$	duty cycle < 2%, $tpw < 100\mu s$ , $T_J = 125^\circ C$ , $V_{VS} = 4.6V$ , $V_{BG} = 4V (src)$ or $V_{LOWDR} = 0.5V (sink)$		1.2 1.0		$\Omega$

**POWER MANAGEMENT**
**Electrical Characteristics - AC Operating Specifications**

Parameter	Symbol	Conditions	Min	Typ	Max	Units
<b>High Side Driver</b>						
rise time	$t_{r_{TG1}}$	CI = 3nF, $V_{BST} - V_{DRN} = 4.6V$ ,		14	23	ns
fall time	$t_{f_{TG}}$	CI = 3nF, $V_{BST} - V_{DRN} = 4.6V$ ,		12	19	ns
propagation delay time, TG going high	$tpdh_{TG}$	CI = 3nF, $V_{BST} - V_{DRN} = 4.6V$ , <b>C-delay=0</b>		20	32	ns
propagation delay time, TG going low	$tpdl_{TG}$	CI = 3nF, $V_{BST} - V_{DRN} = 4.6V$ ,		15	24	ns
<b>Low-Side Driver</b>						
rise time	$t_{r_{BG}}$	CI = 3nF, $V_{V_S} = 4.6V$ ,		15	24	ns
fall time	$t_{f_{BG}}$	CI = 3nF, $V_{V_S} = 4.6V$ ,		13	21	ns
propagation delay time, BG going high	$tpdh_{BGHI}$	CI = 3nF, $V_{BST} - V_{DRN} = 4.6V$ , <b>C-delay=0</b>		12	19	ns
propagation delay time, TG going low	$tpdl_{BG}$	CI = 3nF, $V_{V_S} = 4.6V$ , DRN < 1V		7	12	ns
<b>Under-Voltage Lockout</b>						
V_5 ramping up	$tpdh_{UVLO}$	EN is High			10	us
V_5 ramping down	$tpdh_{UVLO}$	EN is High			10	us
<b>PRDY</b>						
EN is transitioning from low to high	$tpdhPRDY$	$V_5 > UVLO$ threshold, Delay measured from EN > 2.0V to PRDY > 3.5V			10	μs
EN is transitioning fro high to low	$tpdhUVLO$	$V_5 > UVLO$ threshold, Delay measured from EN < 0.8V to PRDY < 10% of $V_5V$			500	μs
<b>DSPS_DR</b>						
rise/fall time	$t_{r_{DSPS\_DR}}$	CI = 100 pf, $V_5 = 4.6V$			20	ns
propagation delay, DSPS_DR going high	$tpdh_{DSPS\_DR}$	S_MOD goes high and BG goes high or S_MOD goes low			10	ns
propagation delay, DSPS_DR goes low	$tpdl_{DSPS\_DR}$	S_MOD goes high and BG goes low			10	ns
<b>Overvoltage Protection</b>						
propagation delay	$tpdh_{OVP_S}$	$V_5 + 4.6V$ , $T_J = 125^{\circ}C$ , $OVP\_S > 1.2V$ to BG > 90% of $V_5$			1	μs

Note:

(1) This device is ESD sensitive. Use of standard ESD handling precautions is required.

**POWER MANAGEMENT**

**Timing Diagrams**

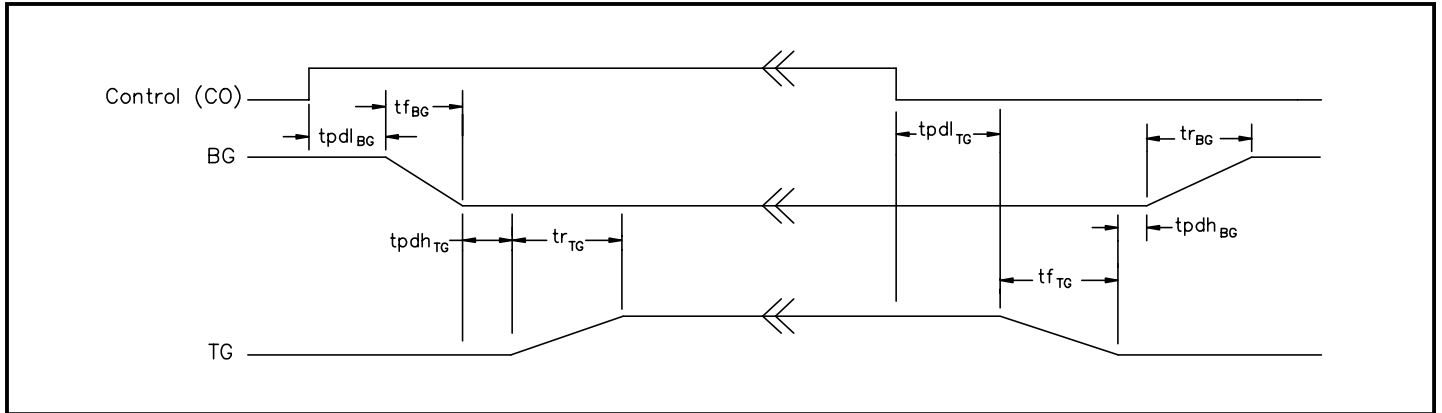

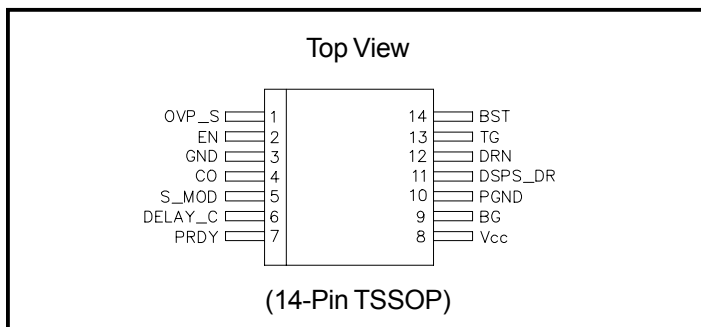
**POWER MANAGEMENT**
**Pin Configuration**

**Ordering Information**

Device <sup>(1)</sup>	Package	Temp Range (T <sub>J</sub> )
SC1405BTS.TR	TSSOP-14	0 to 125°C

**Note:**

(1) Only available in tape and reel packaging. A reel contains 2500 devices.

**Pin Descriptions**

Pin #	Pin Name	Pin Function
1	OVP_S	Overvoltage protection sense. External scaling resistors required to set protection threshold.
2	EN	When high, this pin enables the internal circuitry of the device. When low, TG, BG, and PRDY are forced low and the supply current (5V) is less than 10µA.
3	GND	Logic GND.
4	CO	TTL-level input signal to the MOSFET drivers.
5	S_MOD	When low, this signal forces BG to be low, triggering asynchronous operation. When high, BG is not a function of this signal.
6	DELAY_C	The capacitance connected between this pin and GND sets the additional propagation delay for BG going low to TG going high. Total propagation delay = 20ns + 1ns/pF. If no capacitor is connected, the propagation delay = 20ns.
7	PRDY	This pin indicates the status of VCC. When VCC is less than the UVLO threshold, this output is driven low. When VCC is greater than or equals to the UVLO threshold this output goes high.
8	VCC	Input supply of 5V - 6V. A .22-1µF ceramic capacitor should be connected from VCC to PGND very close to the chip.
9	BG	Output drive for the synchronous (bottom) MOSFET.
10	PGND	Power ground. Connect to the synchronous FET source pin (power ground).
11	DSPS_DR	Dynamic Set Point Switch Drive. TTL level output signal. When S-MOD is high, this pin follows the BG driver pin voltage.
12	DRN	This pin connects to the junction of the switching and synchronous MOSFET's. This pin can be subjected to a -2V minimum relative to PGND without affecting operation.
13	TG	Output gate drive for the switching (high-side) MOSFET.
14	BST	Bootstrap pin. A capacitor is connected between BST and DRN pins to develop the floating bootstrap voltage for the high-side MOSFET. The capacitor value is typically between 0.1µF and 1µF (ceramic).

**NOTE:**

(1) All logic level inputs and outputs are open collector TTL compatible.

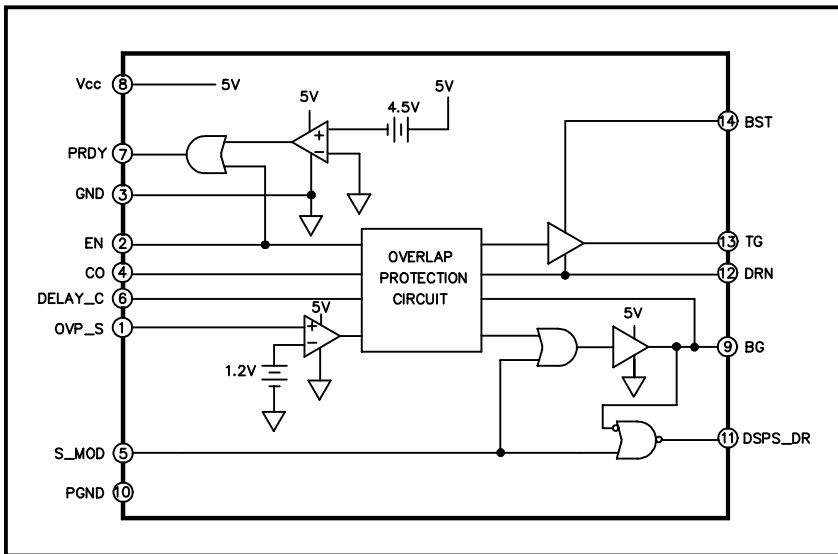
**POWER MANAGEMENT**
**Block Diagram**

**Applications Information**

**SC1405B** is the higher speed version of the SC1405. It is designed to drive Low  $R_{ds\_On}$  power MOSFET's with ultra-low rise/fall times and propagation delays. As the switching frequency of PWM controllers is increased to reduce power supply and Class-D amplifier volume and cost, fast rise and fall times are necessary to minimize switching losses (TOP MOSFET) and reduce Dead-time (BOTTOM MOSFET) losses. While Low  $R_{ds\_On}$  MOSFET's present a power saving in  $I^2R$  losses, the MOSFET's die area is larger and thus the effective input capacitance of the MOSFET is increased. Often a 50% decrease in  $R_{ds\_On}$  more than doubles the effective input gate charge, which must be supplied by the driver. The  $R_{ds\_On}$  power savings can be offset by the switching and dead-time losses with a suboptimum driver. While discrete solution can achieve reasonable drive capability, implementing shoot-through, programmable delay and other housekeeping functions necessary for safe operation can become cumbersome and costly. The SC1405 family of parts presents a total solution for the high-speed, high power density =applications. Wide input supply range of 4.5V-25V allows use in battery powered applications, new high voltage, distributed power servers as well as Class-D amplifiers.

**Theory of Operation**

The control input (CO) to the SC1405B is typically supplied by a PWM controller that regulates the power supply output. (See Application Evaluation Schematic, Figure 3). The timing diagram demonstrates the sequence

of events by which the top and bottom drive signals are applied. The shoot-through protection is implemented by holding the bottom FET off until the voltage at the phase node (intersection of top FET source, the output inductor and the bottom FET drain) has dropped below 1V. This assures that the top FET has turned off and that a direct current path does not exist between the input supply and ground, a condition which both the top and bottom FET's are on momentarily. The top FET is also prevented from turning on until the bottom FET is off. This time is internally set to 20ns (typical) and may be increased by adding a capacitor from the C-Delay pin to GND. The delay is approximately 1ns/pf in addition to the internal 20ns delay. The external capacitor may be needed if multiple High input capacitance MOSFET's are used in parallel and the fall time is substantially greater than 20ns.

It must be noted that increasing the dead-time by high values of C-Delay capacitor will reduce efficiency since the parallel Schottky or the bottom FET body diode will have to conduct during dead-time.

**Layout Guidelines**

As with any high speed , high current circuit, proper layout is critical in achieving optimum performance of the SC1405B. The Evaluation board schematic (Refer to figure 3) shows a dual phase synchronous design with all surface mountable components.

**POWER MANAGEMENT**
**Applications Information**

While components connecting to C-Delay, OVP\_S, EN,S-MOD, DSPS\_DR and PRDY are relatively non-critical, tight placement and short,wide traces must be used in layout of The Drives, DRN, and especially PGND pin. The top gate driver supply voltage is provided by bootstrapping the +5V supply and adding it the phase node voltage (DRN). Since the bootstrap capacitor supplies the charge to the TOP gate, it must be less than .5" away from the SC1405. Ceramic X7R capacitors are a good choice for supply bypassing near the chip. The Vcc pin capacitor must also be less than .5" away from the SC1405. The ground node of this capacitor, the SC1405 PGND pin and the Source of the bottom FET must be very close to each other, preferably with common PCB copper land and multiple vias to the ground plane (if used). The parallel Shottkey must be physically next to the Bottom FETS Drain and source. Any trace or lead inductance in these connections will drive current way from the Shottkey and allow it to flow through the FET's Body diode, thus reducing efficiency.

**Preventing Inadvertent Bottom FET Turn-on**

At high input voltages, (12V and greater) a fast turn-on of the top FET creates a positive going spike on the Bottom FET's gate through the Miller capacitance, Crss of the bottom FET. The voltage appearing on the gate due to this spike is:

$$V_{\text{SPIKE}} = \frac{V_{\text{IN}} * C_{\text{RSS}}}{(C_{\text{RSS}} + C_{\text{ISS}})}$$

Where Ciss is the input gate capacitance of the bottom FET. This is assuming that the impedance of the drive path is too high compared to the instantaneous impedance of the capacitors. (since dV/dT and thus the effective frequency is very high). If the BG pin of the SC1405B is very close to the bottom FET, Vspike will be reduced depending on trace inductance, rate if rise of current,etc.

While not shown in Figure 4, a capacitor may be added from the gate of the Bottom FET to its source, preferably less than .5" away. This capacitor will be added to Ciss in the above equation to reduce the effective spike voltage, Vspike.

The selection of the bottom MOSFET must be done with attention paid to the Crss/Ciss ratio. A low ratio reduces the Miller feedback and thus reduces Vspike. Also

MOSFETs with higher Turn-on threshold voltages will conduct at a higher voltage and will not turn on during the spike. The MOSFET shown in the schematic (figure 4) has a 2 volt threshold and will require approximately 5 volts Vgs to be conducting, thus reducing the possibility of shoot-through. A zero ohm bottom FET gate resistor will obviously help keeping the gate voltage low.

Ultimately, slowing down the top FET by adding gate resistance will reduce di/dt which will in turn make the effective impedance of the capacitors higher, thus allowing the BG driver to hold the bottom gate voltage low.

**Ringings on the Phase Node**

The top MOSFET source must be close to the bottom MOSFET drain to prevent ringing and the possibility of the phase node going negative. This frequency is determined by:

$$F_{\text{RING}} = \frac{1}{(2\pi * \sqrt{L_{\text{ST}} * C_{\text{OSS}}})}$$

Where:

$L_{\text{st}}$  = The effective stray inductance of the top FET added to trace inductance of the connection between top FET's source and the bottom FET's drain added to the trace resistance of the bottom FET's ground connection.

Coss=Drain to source capacitance of bottom FET. If there is a Shottkey used, the capacitance of the Shottkey is added to the value.

Although this ringing does not pose any power losses due to a fairly high Q, it could cause the phase node to go too far negative, thus causing improper operation, double pulsing or at worst driver damage. This ringing is also an EMI nuisance due to its high resonant frequency. Adding a capacitor, typically 1000-2000pf, in parallel with Coss can often eliminate the EMI issue. If double pulsing is caused due to excessive ringing, placing 4.7-10 ohm resistor between the phase node and the DRN pin of the SC1405 should eliminate the double pulsing.

The negative voltage spikes on the phase node adds to the bootstrap capacitor voltage, thus increasing the voltage between VBST - VDRN. If the phase node negative spikes are too large, the voltage on the boost capacitor could exceed device's absolute maximum rating of 8V.



**POWER MANAGEMENT****Applications Information (Cont.)**

To eliminate the effect of the ringing on the boost capacitor voltage, place a 4.7 - 10 Ohm resistor between boost Schottky diode and Vcc to filter the negative spikes on DRN Pin. Alternately, a Silicon diode, such as the commonly available 1N4148 can substitute for the Schottky diode and eliminate the need for the series resistor.

Proper layout will guarantee minimum ringing and eliminate the need for external components. Use of SO-8 or other surface mount MOSFETs will reduce lead inductance and their parasitic effects.

**ASYNCHRONOUS OPERATION**

The SC1405B can be configured to operate in Asynchronous mode by pulling S-MOD to logic LOW, thus disabling the bottom FET drive. This has the effect of saving power at light loads since the bottom FET's gate capacitance does not have to be charged at the switching frequency. There can be a significant savings since the bottom driver can supply up to 2A pulses to the FET at the switching frequency. There is an additional efficiency benefit to operating in asynchronous mode. When operating in synchronous mode, the inductor current can go negative and flow in reverse direction when the bottom FET is on and the DC load is less than 1/2 inductor ripple current.

At that point, the inductor core and wire losses, depending on the magnitude of the ripple current, can be quite significant. Operating in asynchronous mode at light loads effectively only charges the inductor by as much as needed to supply the load current, since the inductor never completely discharges at light loads. DC regulation can be an issue when operating in asynchronous mode, depending on the type of controller used and minimum load required to maintain regulation. If there are no Schottky diodes used in parallel with bottom FET, the FET's body diode will need to conduct in asynchronous mode. The high voltage drop of this diode must be considered when determining the criteria for this mode of operation.

**DSPS DR**

This pin produces an output which is a logical duplicate of the bottom FET's gate drive, if S-MOD is held LOW.

**OVP\_S/OVER TEMP SHUTDOWN**

Output over-voltage protection may be implemented on the SC1405 independent of the PWM controller. A voltage divider from the output is compared with the internal bandgap voltage of 1.2V (typical). Upon exceeding this voltage, the overvoltage comparator disables the top FET, while turning on the bottom FET to allow discharge of the output capacitors excessive voltage through the output inductor. There should be sufficient RC time constant as well as voltage headroom on the OVP\_S pin to assure it does not enter overvoltage mode inadvertently. The SC1405 will shutdown if its Tj exceeds 165°C.

**POWER MANAGEMENT**

**Typical Characteristics**

Performance diagrams, Application Evaluation Board.

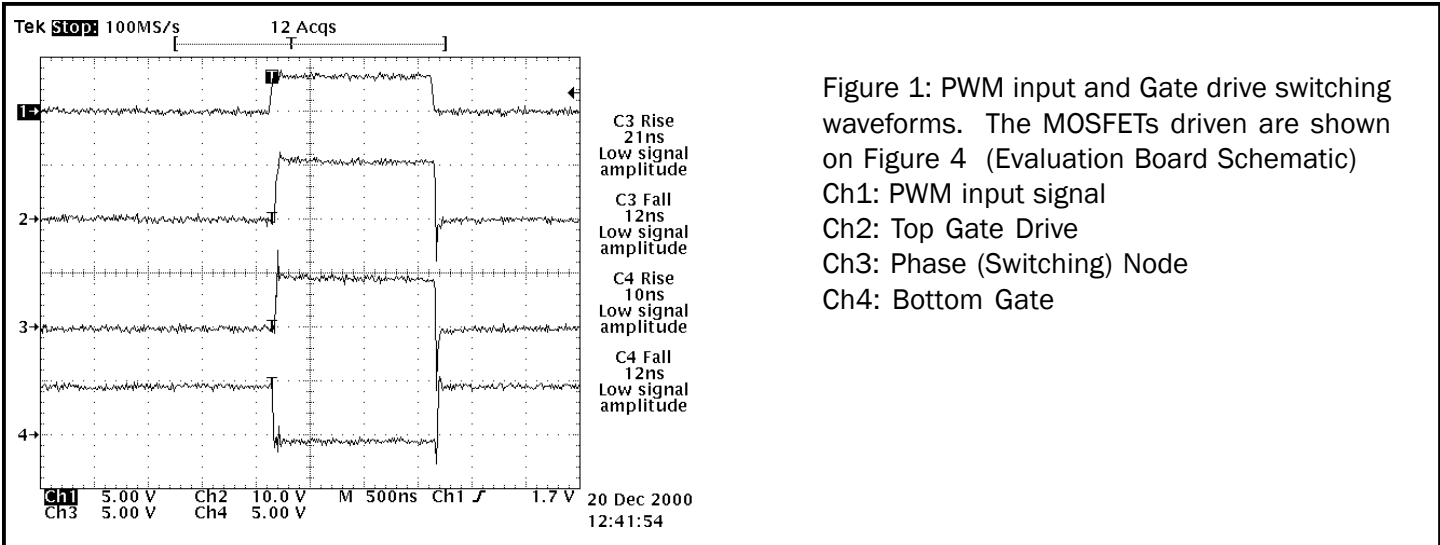

Figure 1: PWM input and Gate drive switching waveforms. The MOSFETs driven are shown on Figure 4 (Evaluation Board Schematic)

Ch1: PWM input signal  
Ch2: Top Gate Drive  
Ch3: Phase (Switching) Node  
Ch4: Bottom Gate

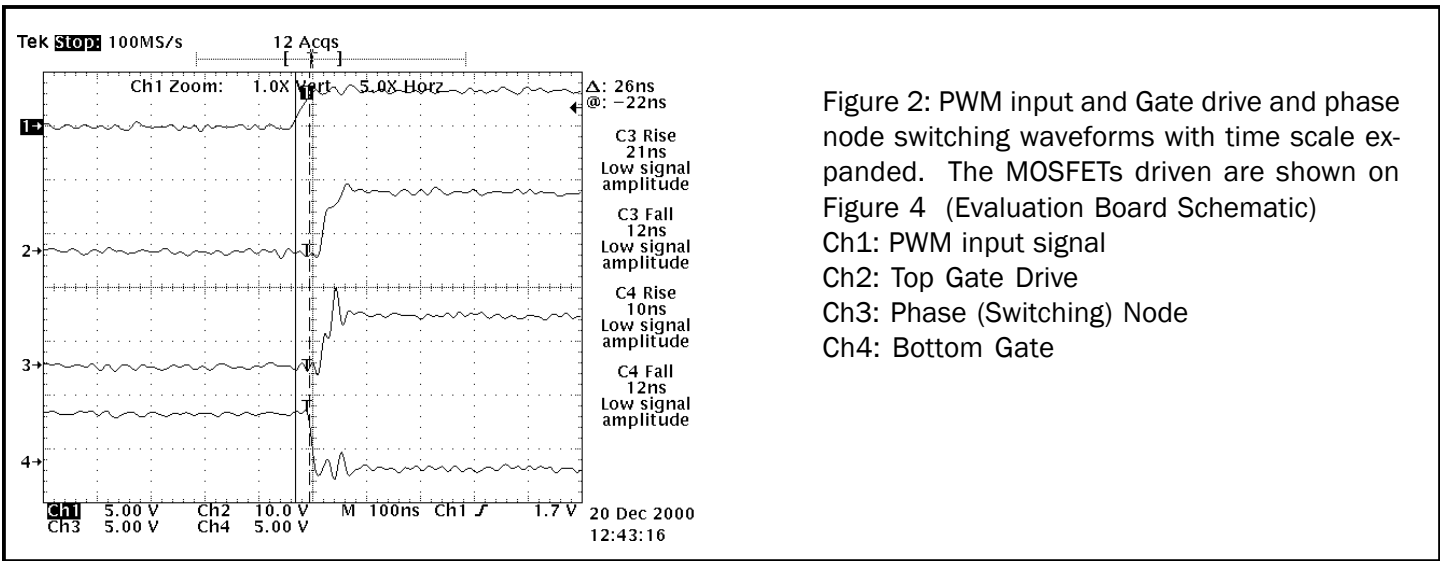

Figure 2: PWM input and Gate drive and phase node switching waveforms with time scale expanded. The MOSFETs driven are shown on Figure 4 (Evaluation Board Schematic)

Ch1: PWM input signal  
Ch2: Top Gate Drive  
Ch3: Phase (Switching) Node  
Ch4: Bottom Gate

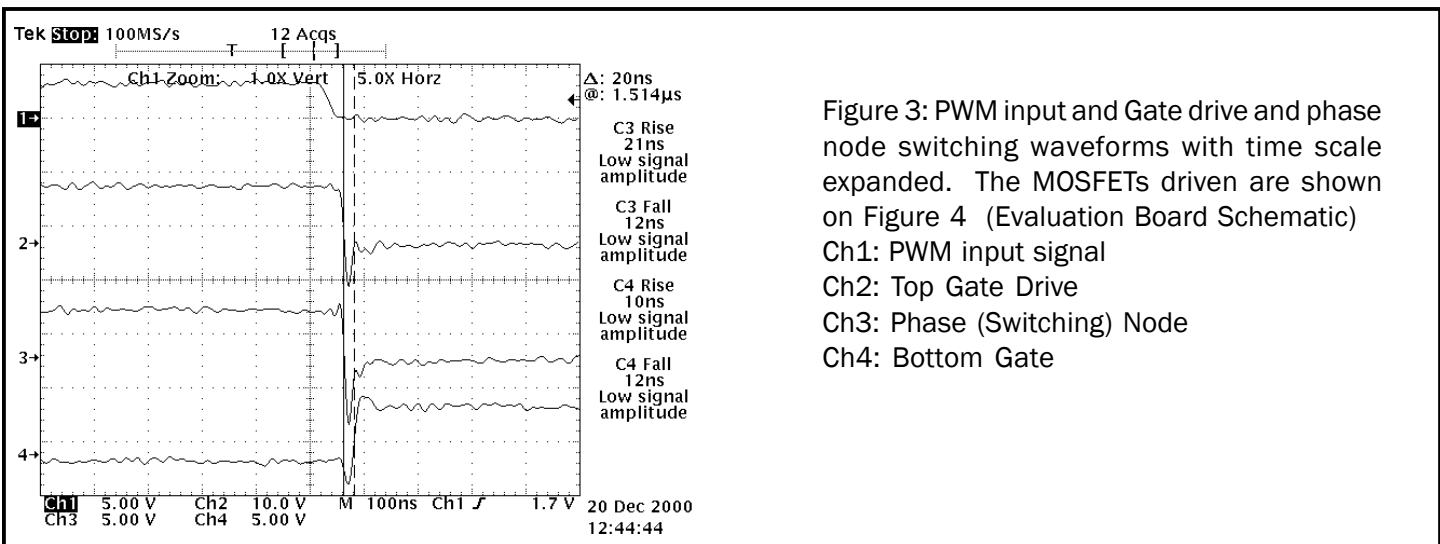

Figure 3: PWM input and Gate drive and phase node switching waveforms with time scale expanded. The MOSFETs driven are shown on Figure 4 (Evaluation Board Schematic)

Ch1: PWM input signal  
Ch2: Top Gate Drive  
Ch3: Phase (Switching) Node  
Ch4: Bottom Gate



**POWER MANAGEMENT**
**Evaluation Board Bill of Materials**

Item	Qty.	Reference	Value	Manufacturer
1	12	C1, C4, C5, C15, C17, C18, C19, C22, C23, C25, C28, C29	01u, Cer.	Murata, TDK
2	1	C2	33uf, OS	Sanyo
3	3	C3, C6, C11	1uF	
4	1	C7	1u, 16V	
5	1	C8	1000uf, 16V	Panasonic
6	2	C9, C26	10nf	
7	2	C10, C13	820uf, OS	Sanyo
8	2	C21, C12	10uf	
9	3	C14, C20, C30	.1	
10	2	C16, C27	.01	
11	1	C24	220pf	
12	2	D4, D2	5819	
13	1	J1	INPUT	
14	2	L2, L1	PIT1103_luh	Falco (Falcousa.com)
15	2	Q1, Q3	FDB6035	Fairchild
16	2	Q2, Q4	FDB7030	Fairchild
17	1	R1	.002	Dale
18	2	R3, R2	10	
19	1	R4	10k	
20	4	R5, R6, R9, R13	0	
21	2	R12, R7	2.2	
22	4	R8, R16, R18, R19	7.5K	
23	1	R10	120K	
24	1	R11	1K	
25	1	R14	13K	
26	1	R15	26.1k	
27	1	R17	1	
28	1	R20	3.6K	
29	1	U2	SC2422	Semtech
30	2	U1, U3	SC1405B	Semtech

**POWER MANAGEMENT**

**Outline Drawing -TSSOP-14**

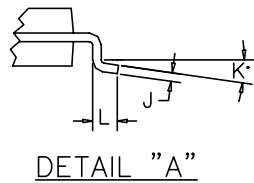
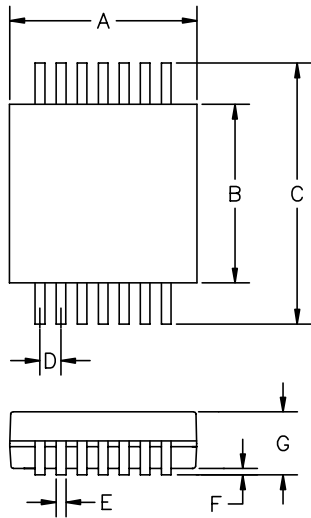

DIM <sup>N</sup>	DIMENSIONS ①				NOTE
	INCHES		MM		
A	.193	.201	4.90	5.10	②
B	.169	.177	4.30	4.50	②
C	.252 BSC		6.40 BSC		—
D	.026 BSC		.65 BSC		—
E	.007	.012	.19	.30	—
F	.002	.006	.05	.15	—
G	.047		1.20		—
J	.004	.008	.09	.20	—
K	0°	8°	0°	8°	—
L	.018	.030	.45	.75	—

JEDEC MO-153AB1

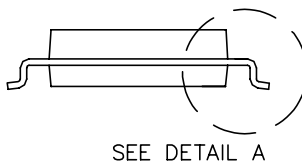

- ② DIMENSIONS A AND B DO NOT INCLUDE MOLD PROTRUSIONS.
- ① CONTROLLING DIMENSIONS: MILLIMETERS.

**Land Pattern - TSSOP-14**

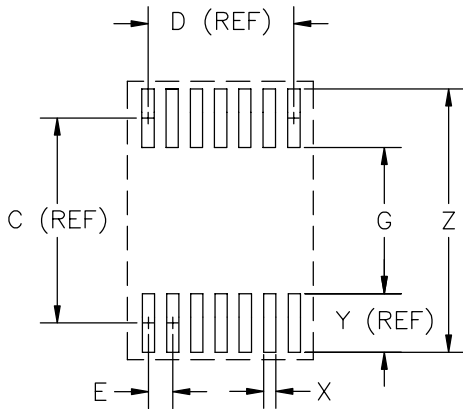

DIM <sup>N</sup>	DIMENSIONS ①				NOTE
	INCHES		MM		
C	—	.218	—	5.53	REF
D	—	.156	—	3.96	REF
E	—	.026	—	0.65	BSC
G	.155	—	3.947	—	—
X	—	.013	—	0.323	REF
Y	—	.062	—	1.583	—
Z	—	.280	—	7.113	—

- ② GRID PLACEMENT COURTYARD IS 10 X 15 ELEMENTS (5mm X 7.5mm) IN ACCORDANCE WITH THE INTERNATIONAL GRID DETAILED IN THE IEC PUBLICATION 97.
- ① CONTROLLING DIMENSIONS: MILLIMETERS.

**Contact Information**

Semtech Corporation  
 Power Management Products Division  
 200 Flynn Road, Camarillo, CA 93012  
 Phone: (805)498-2111 FAX (805)498-3804