

REV.	ECN. NO.	NAME	DATE

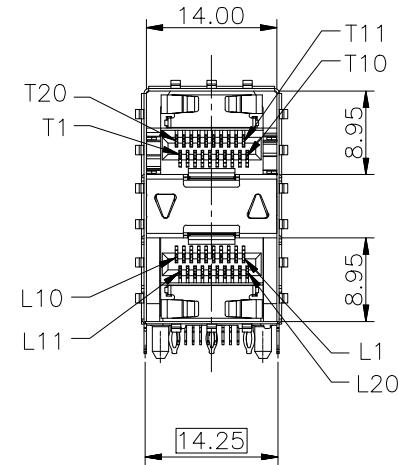
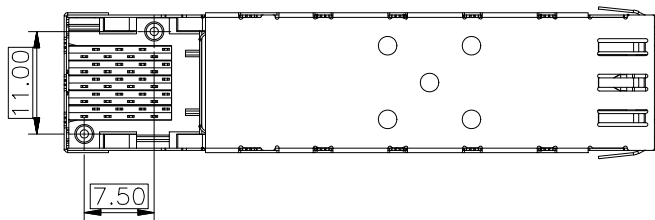
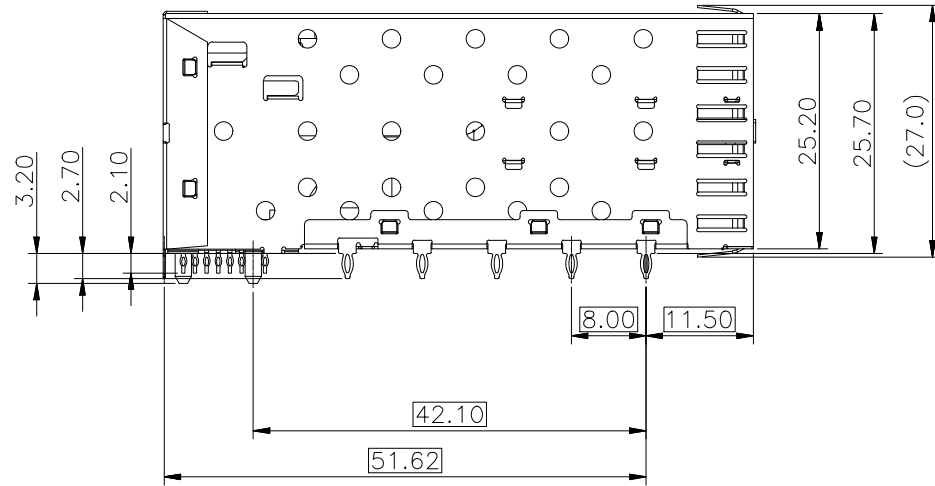
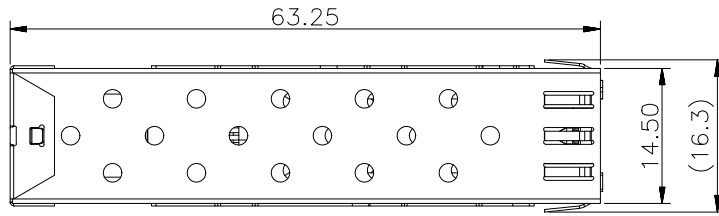

NOTES:

MATERIAL:
 CAGE: NICKEL SILVER, THICKNESS 0.25mm
 CONNECTOR:
 PLASTIC HOUSING: HIGH TEMPERATURE LCP, UL94 V-0.
 SPRING: STAINLESS STEEL, THICKNESS 0.20mm
 CONTACTS: PHOSPHOR BRONZE, THICKNESS 0.20mm
 PLATING: 15 μ " MIN. GOLD ON MATING AREA,
 150 μ " MIN. MATE TIN ON SOLDER TAILS.

PACKAGING: TRAY PACKAGING.

TEMPERATURE RANGE: -40°C TO +85°C

RoHS Compliant

TOLERANCE UNSPECIFIED				FOR YOUR VITAL CONNECTION	
.0	± 0.38			TITLE: SFP2*1 CAGE+CONN	
.00	± 0.25	DRAWN BY: BECKER		PART NO: SC213	
.000	± 0.10	CHECKED BY: VTA		SIZE: A4	
ANGLE	± 3.00°	APPROVED BY: QPF		UNIT:mm	
MANUFACTURING COPY		PROJECTION		SHEET:10F3	
				REV: A	
				FCN: A4	
				http://www.vitalconn.com	

REV.	ECN. NO.	NAME	DATE

NOTES:

- DATUM AND BASIC DIMENSIONS ESTABLISHED BY CUSTOMER.
- 1.05 mm DIAMETER HOLES ARE CHASSIS GROUND .

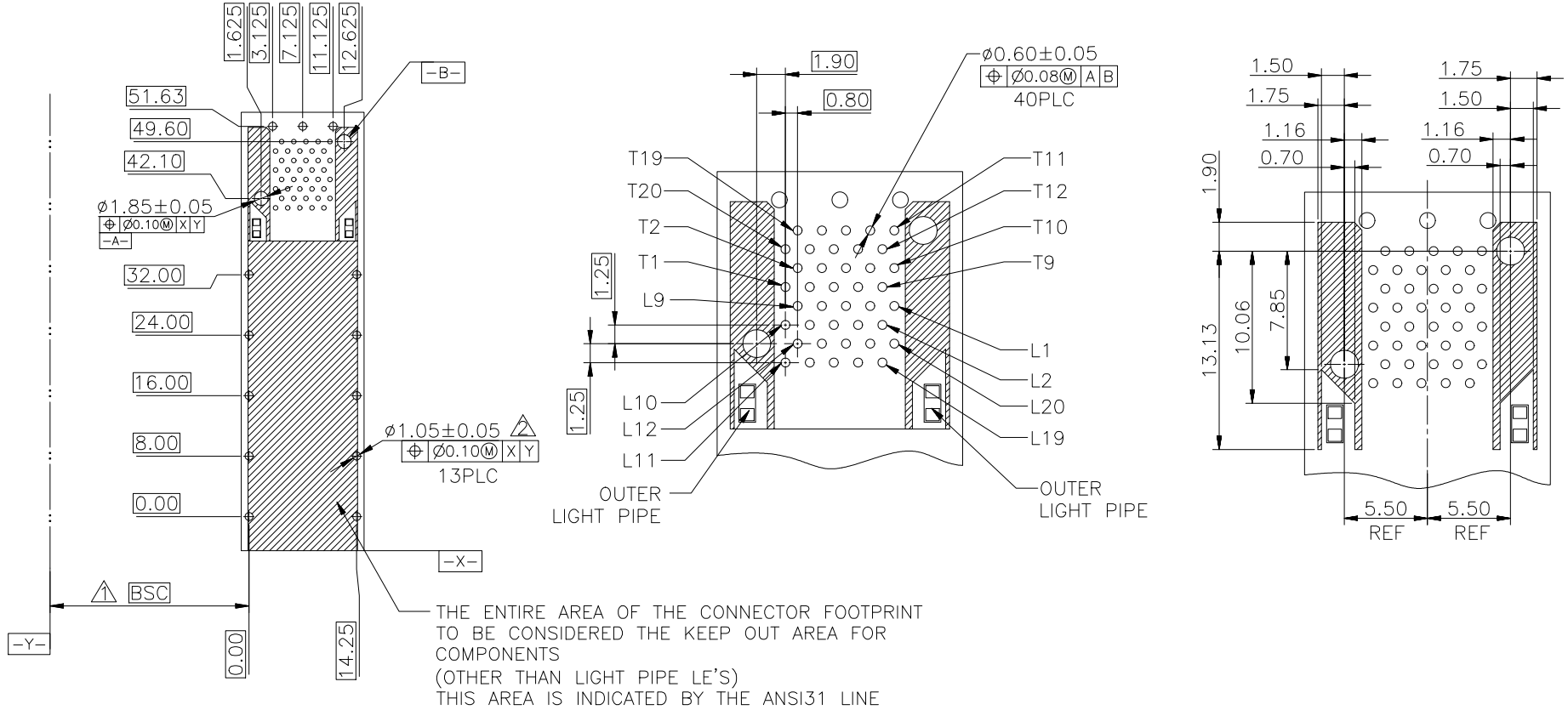

RECOMMENDED PCB CONFIGURATION

RoHS Compliant

TOLERANCE UNSPECIFIED		 VITALCON a vital connector company		FOR YOUR VITAL CONNECTION	
.0	± 0.38				
.00	± 0.25	DRAWN BY: BECKER	PART NO: SC213	REV: A	
.000	± 0.10	CHECKED BY: VTA	SIZE: A4	UNIT:mm	SHEET:20F3
ANGLE	± 3.00°	APPROVED BY: QPF	PROJECTION		FCN: A4
MANUFACTURING COPY				http://www.vitalconn.com	

REV.	ECN. NO.	NAME	DATE

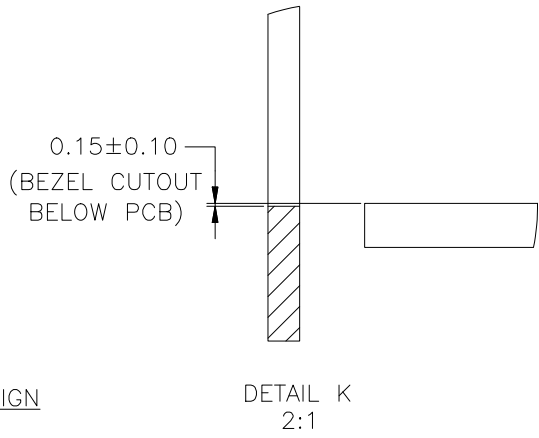
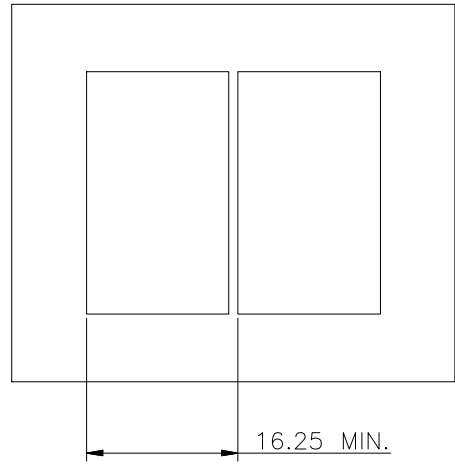
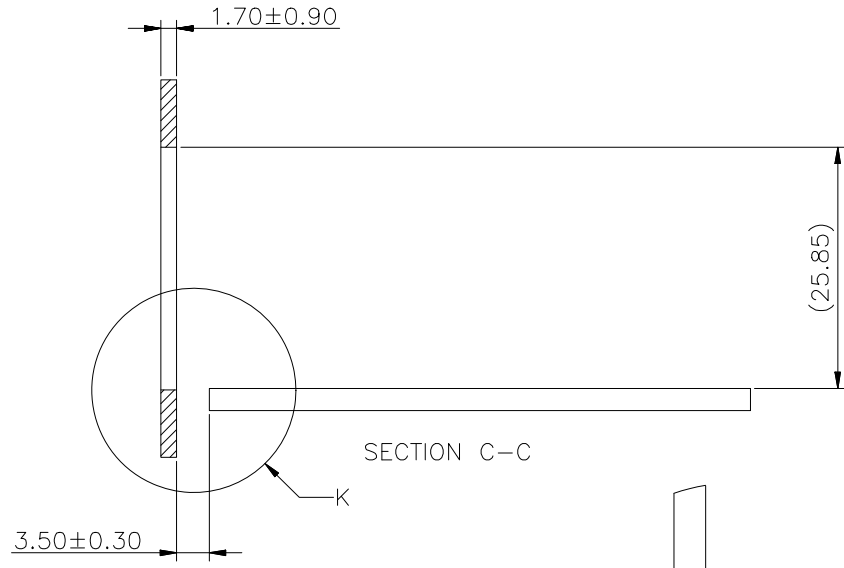
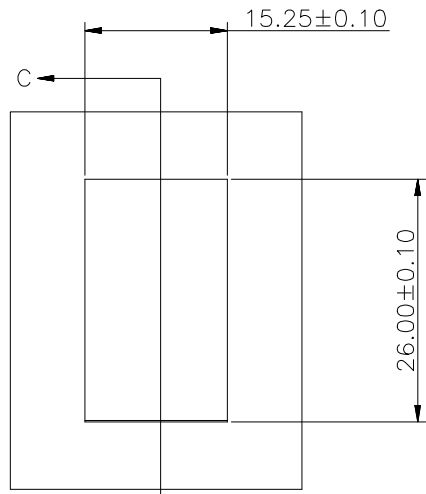

RoHS Compliant

TOLERANCE UNSPECIFIED		VITALCON a vital connector company		FOR YOUR VITAL CONNECTION			
.0	± 0.38			TITLE: SFP2*1 CAGE+CONN			
.00	± 0.25	DRAWN BY:	BECKER	PART NO:	SC213	REV: A	
.000	± 0.10	CHECKED BY:	VTA	SIZE: A4	UNIT:mm	SHEET:30F3	FCN: A4
ANGLE	± 3.00°	APPROVED BY:	QPF	PROJECTION		http://www.vitalconn.com	
MANUFACTURING COPY							