

REV.	ECN. NO.	NAME	DATE

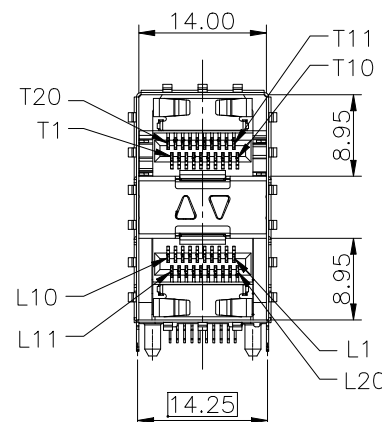
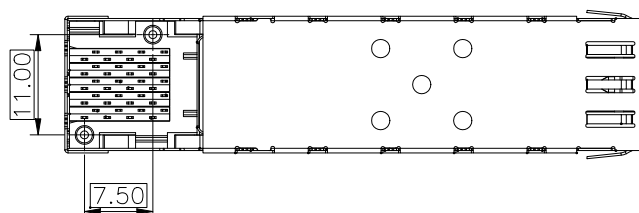
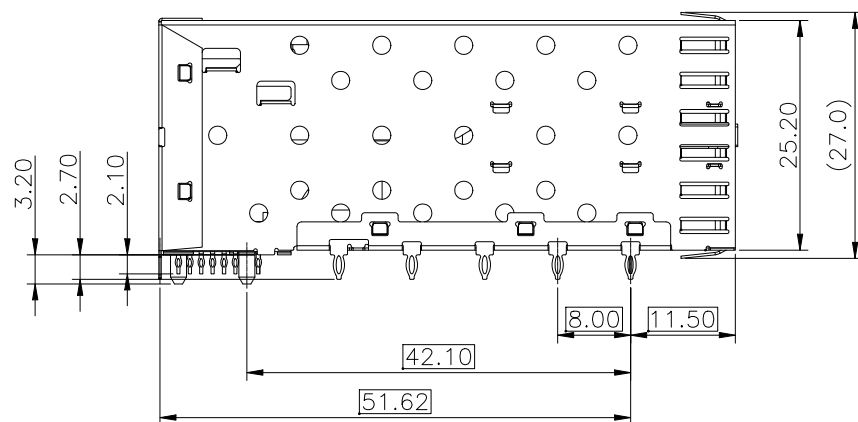
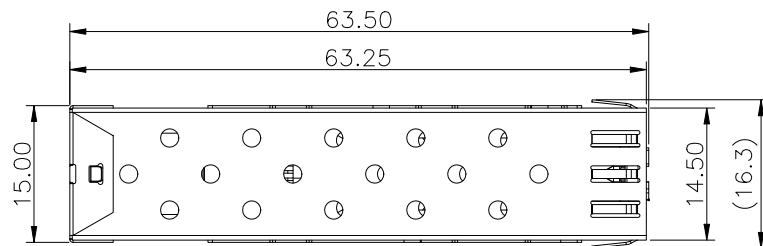

NOTES:

MATERIAL:
 CAGE: COPPER ALLOY THICKNESS 0.25mm
 CONNECTOR:
 PLASTIC HOUSING: HIGH TEMPERATURE LCP, UL94 V-0.
 SPRING: STAINLESS STEEL, THICKNESS 0.20mm
 CONTACTS: PHOSPHOR BRONZE, THICKNESS 0.20mm
 PLATING: 15 μ " MIN. GOLD ON MATING AREA,
 150 μ " MIN. MATE TIN ON SOLDER TAILS.

PACKAGING: TRAY PACKAGING.
 OPERATING TEMPERATURE: -40°C TO +105°C
 STORAGE TEMPERATURE: -55°C TO +105°C

RoHS Compliant

TOLERANCE UNSPECIFIED		VITALCON a vital connector company		FOR YOUR VITAL CONNECTION	
.0	± 0.38			TITLE: SFP2*1 CAGE+CONN	
.00	± 0.25	DRAWN BY:	BECKER	PART NO:	SC214
.000	± 0.10	CHECKED BY:	VTA	SIZE: A4	UNIT:mm
ANGLE	± 3.00°	APPROVED BY:	QPF	PROJECTION	SHEET:10F4
MANUFACTURING COPY				REV: A	FCN: A4
				http://www.vitalconn.com	

REV.	ECN. NO.	NAME	DATE

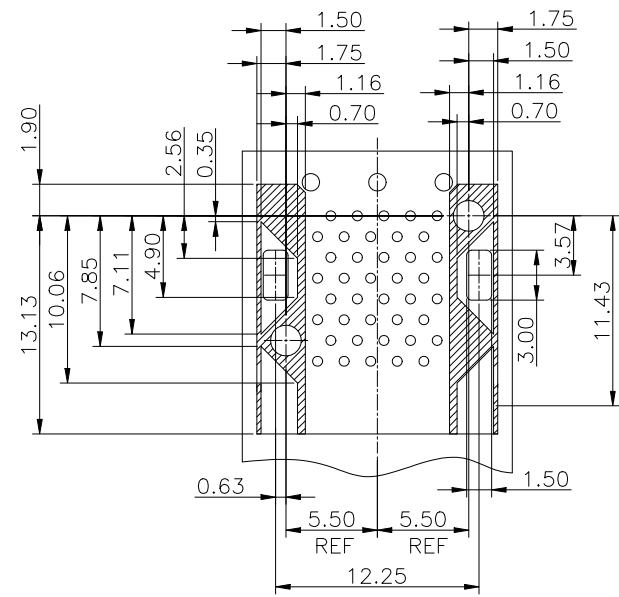
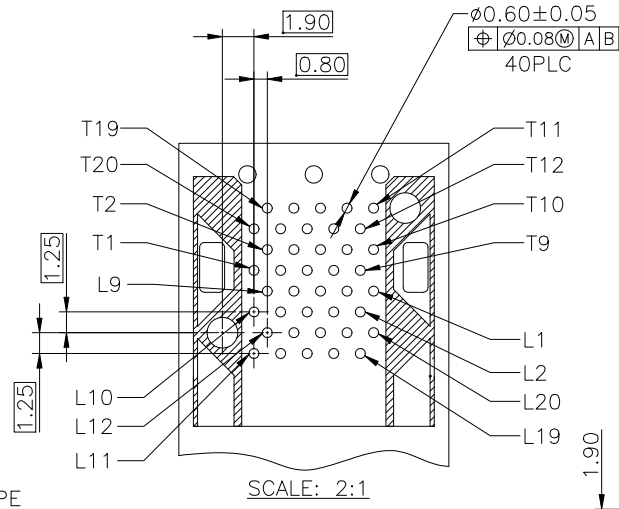
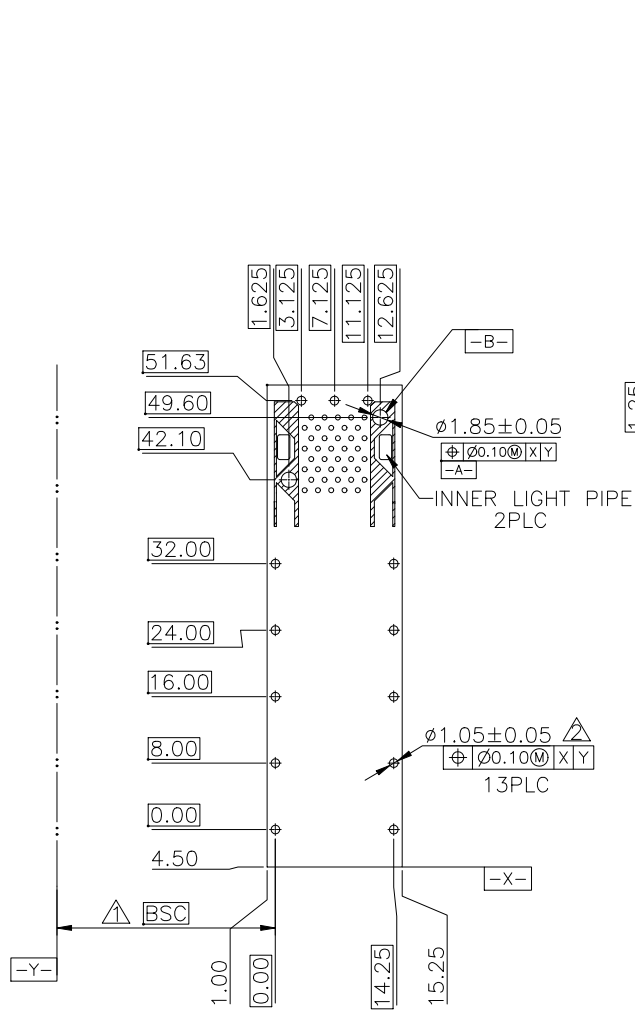

- NOTES:
1. DATUM AND BASIC DIMENSIONS ESTABLISHED BY CUSTOMER.
 2. 1.05 mm DIAMETER HOLES ARE CHASSIS GROUND .

RECOMMENDED PCB CONFIGURATION

RoHS Compliant

TOLERANCE UNSPECIFIED		VITALCON a vital connector company		FOR YOUR VITAL CONNECTION	
.0	± 0.38				
.00	± 0.25	TITLE: SFP2*1 CAGE+CONN			
.000	± 0.10				
ANGLE	± 3.00°				
MANUFACTURING COPY		DRAWN BY: BECKER	PART NO: SC214	REV: A	
CHECKED BY: VTA	SIZE: A4	UNIT:mm	SHEET:20F4	FCN: A4	
APPROVED BY: QPF	PROJECTION			http://www.vitalconn.com	

REV.	ECN. NO.	NAME	DATE

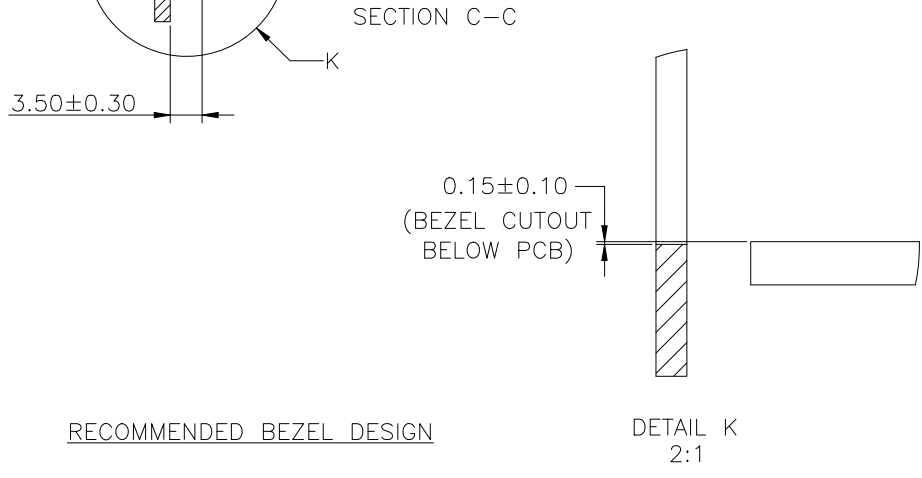
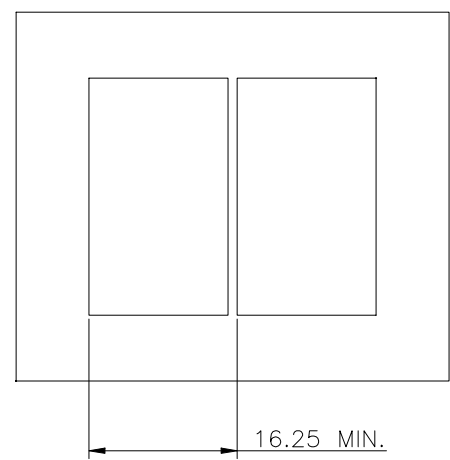
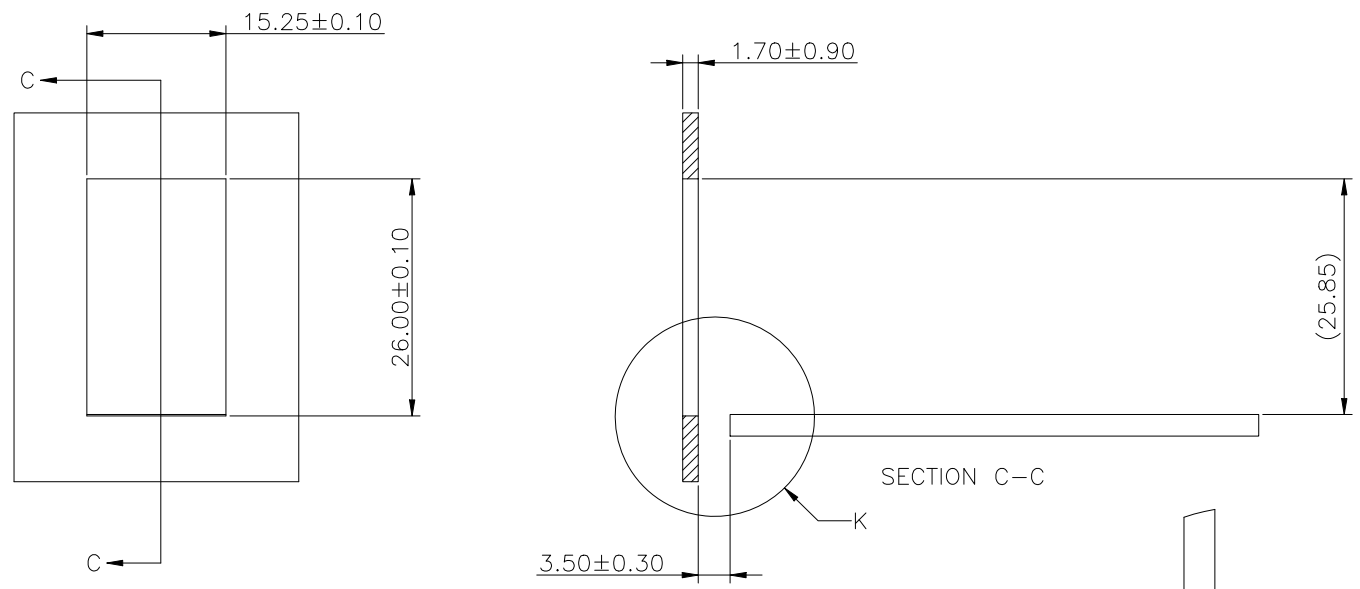

RoHS Compliant

TOLERANCE UNSPECIFIED		VITALCON a vital connector company		FOR YOUR VITAL CONNECTION			
.0	± 0.38			TITLE: SFP2*1 CAGE+CONN			
.00	± 0.25	DRAWN BY:	BECKER	PART NO:	SC214	REV: A	
.000	± 0.10	CHECKED BY:	VTA	SIZE: A4	UNIT:mm	SHEET:30F4	FCN: A4
ANGLE	± 3.00°	APPROVED BY:	QPF	PROJECTION		http://www.vitalconn.com	
MANUFACTURING COPY							

REV.	ECN. NO.	NAME	DATE

PACKAGE INFORMATION AND LABEL

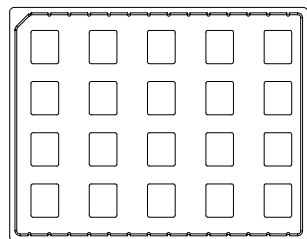

1. PRODUCTS IN TRAYS

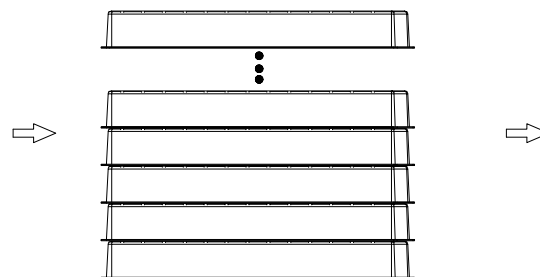

2. TRAYS OVERLAY:
(THE NEXT TRAY NEED ROTATE 180 DEGREE AND PUT IT ON PREVIOUS TRAY.)
(相邻两个吸塑间水平方向成180度摆放)

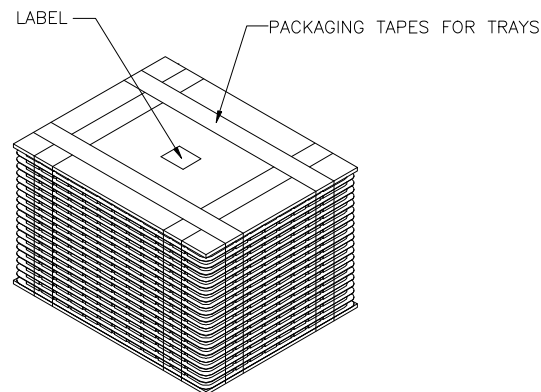

3. LABEL & PACKAGING TAPES FOR TRAYS:

PACKAGING LISTS	
ITEM	Q'TY
PRODUCT	120 PCS
TRAY	6 PCS
BOX(L340*W265*H200MM)	1 PCS
LABLE	2 PCS
PACKAGING TAPES	8 M (ABOUT)

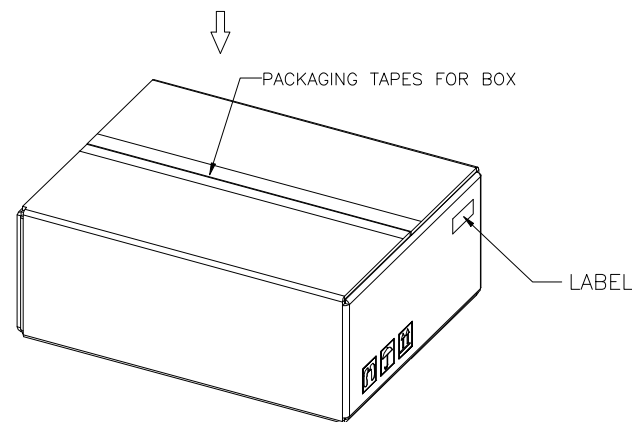

4. LABEL & PACKAGING TAPES FOR BOX

RoHS Compliant

TOLERANCE UNSPECIFIED				FOR YOUR VITAL CONNECTION	
.0	± 0.38			TITLE: SFP2*1 CAGE+CONN	
.00	± 0.25	DRAWN BY: BECKER		PART NO: SC214	
.000	± 0.10	CHECKED BY: VTA		SIZE: A4	
ANGLE	± 3.00°	APPROVED BY: QPF		UNIT:mm	
MANUFACTURING COPY		PROJECTION		SHEET:4OF4	
				REV: A	
				FCN: A4	
				http://www.vitalconn.com	