

REV.	ECN. NO.	NAME	DATE

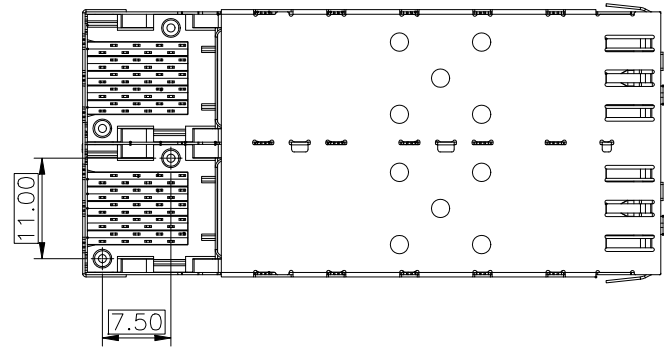
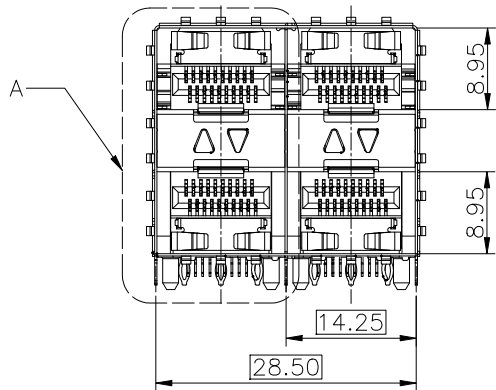
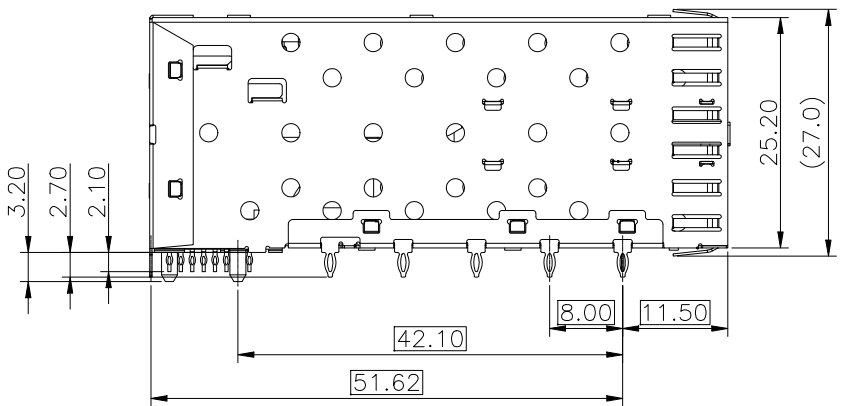
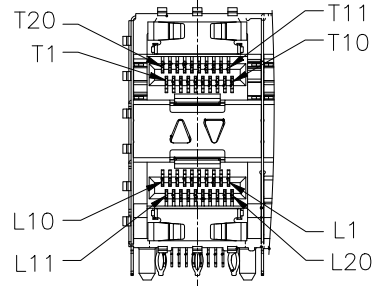
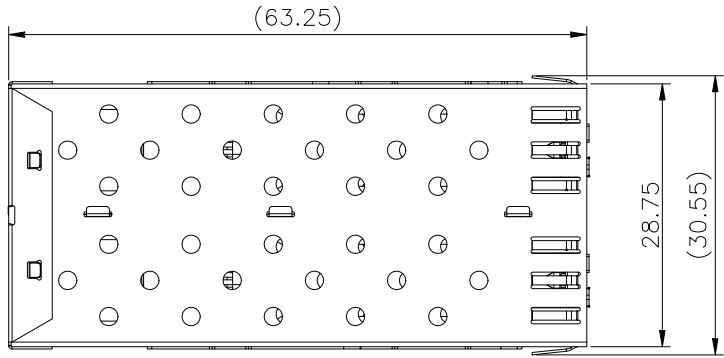

NOTES:

MATERIAL:
 CAGE: COPPER ALLOY THICKNESS 0.25mm
 CONNECTOR:
 PLASTIC HOUSING: HIGH TEMPERATURE LCP, UL94 V-0.
 SPRING: STAINLESS STEEL, THICKNESS 0.20mm
 CONTACTS: PHOSPHOR BRONZE, THICKNESS 0.20mm
 PLATING: 15μ" MIN. GOLD ON MATING AREA,
 150μ" MIN. MATE TIN ON SOLDER TAILS.
 PACKAGING: TRAY PACKAGING.
 OPERATING TEMPERATURE: -40°C TO +105°C
 STORAGE TEMPERATURE: -55°C TO +105°C

RoHS Compliant

TOLERANCE UNSPECIFIED				FOR YOUR VITAL CONNECTION	
.0	± 0.38				
.00	± 0.25	TITLE: SFP2*2 CAGE+CONN			
.000	± 0.10				
ANGLE	± 3.00°				
MANUFACTURING COPY					
DRAWN BY:	BECKER	PART NO:	SC224	REV: A	
CHECKED BY:	VTA	SIZE: A4	UNIT:mm	SHEET:10F3	FCN: A4
APPROVED BY:	QPF	PROJECTION		http://www.vitalconn.com	

REV.	ECN. NO.	NAME	DATE

NOTES:

- DATUM AND BASIC DIMENSIONS ESTABLISHED BY CUSTOMER.
- 1.05 mm DIAMETER HOLES ARE CHASSIS GROUND).

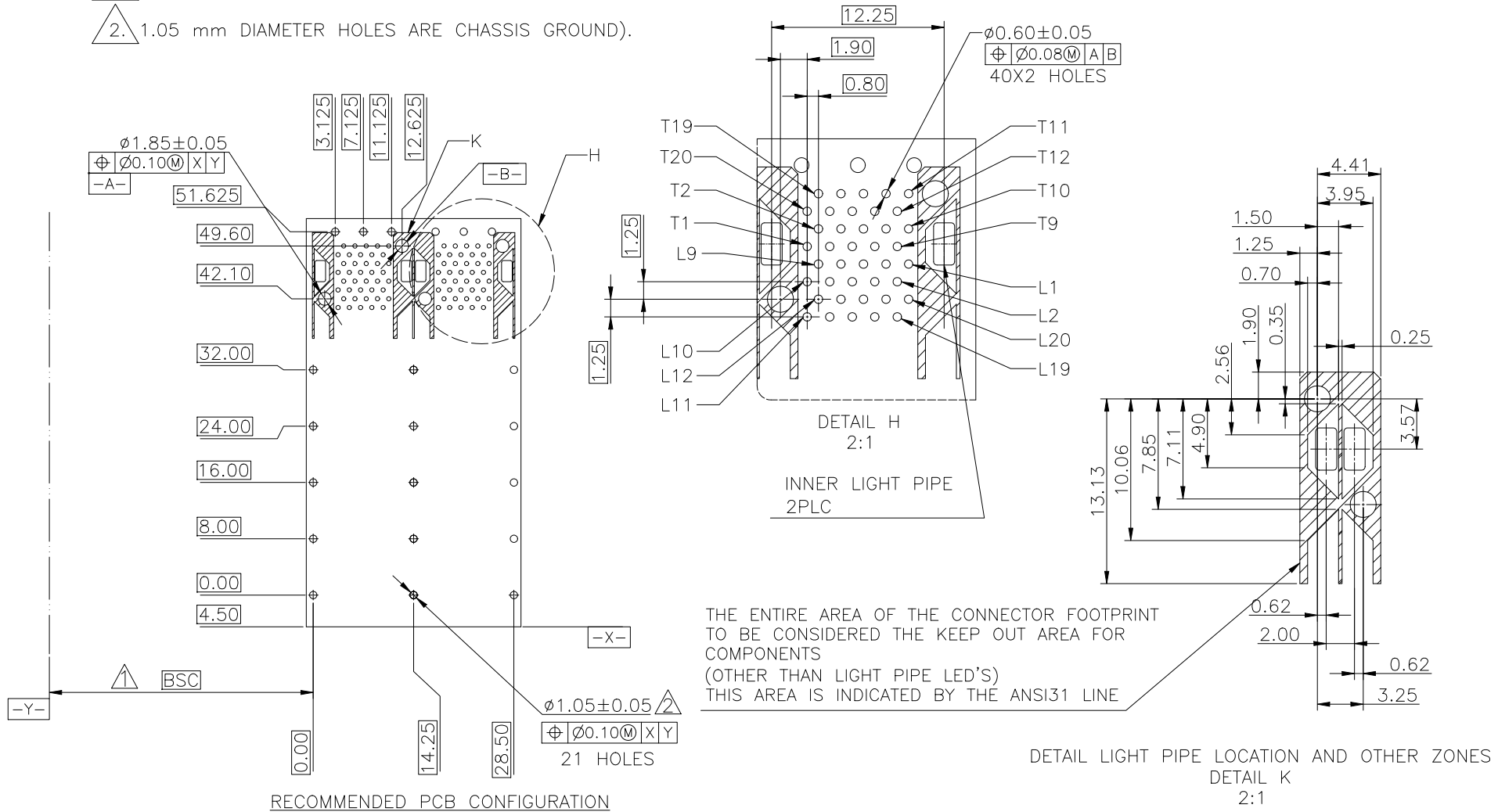

RoHS Compliant

TOLERANCE UNSPECIFIED		VITALCON a vital connector company		FOR YOUR VITAL CONNECTION	
.0	± 0.38			TITLE: SFP2*2 CAGE+CONN	
.00	± 0.25	DRAWN BY: BECKER	PART NO: SC224	REV: A	
.000	± 0.10	CHECKED BY: VTA	SIZE: A4	UNIT:mm	SHEET:20F3
ANGLE	± 3.00°	APPROVED BY: QPF	PROJECTION		http://www.vitalconn.com
MANUFACTURING COPY					

REV.	ECN. NO.	NAME	DATE

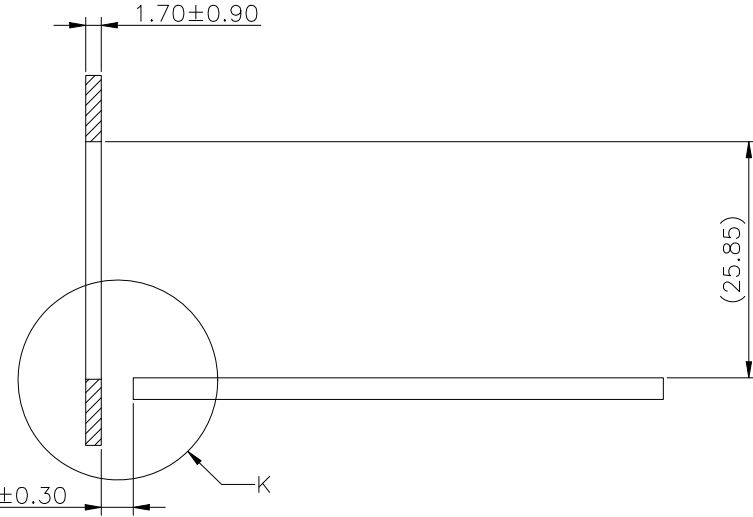
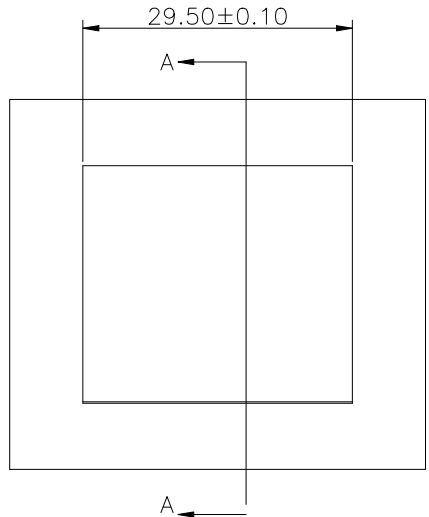

SECTION A-A

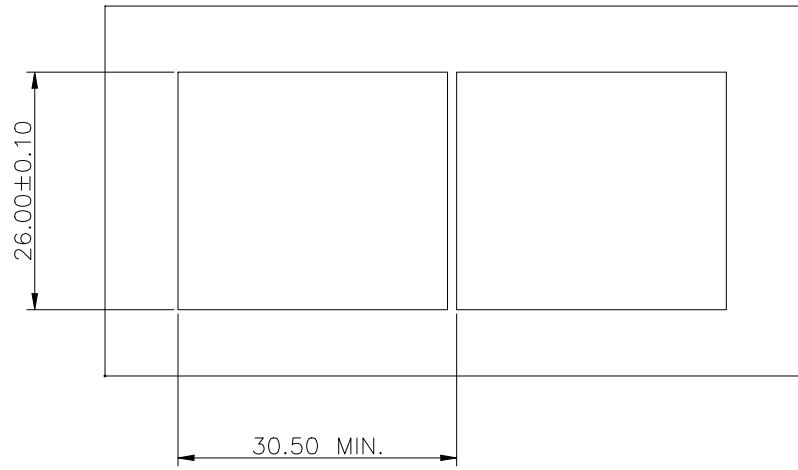

RECOMMENDED BEZEL DESIGN

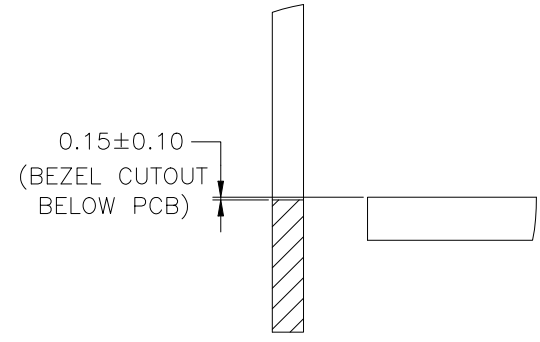

DETAIL K
2:1

RoHS Compliant

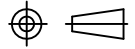
TOLERANCE UNSPECIFIED		 VITALCON a vital connector company		FOR YOUR VITAL CONNECTION	
.0	± 0.38			TITLE: SFP2*2 CAGE+CONN	
.00	± 0.25	DRAWN BY:	BECKER	PART NO:	SC224
.000	± 0.10	CHECKED BY:	VTA	SIZE: A4	UNIT:mm
ANGLE	± 3.00°	APPROVED BY:	QPF	PROJECTION	
MANUFACTURING COPY		SHEET:30F3		http://www.vitalconn.com	
		REV: A		FCN: A4	