Linear Hall Effect Sensor Ics with Analog output

FEATURES

- 3.5 to 10.5V wide supply voltage range
- 4.5mA power consumption for 5 VDC
- Output voltage proportional to magnetic flux density
- -40°C to 150°C wide ambient temperature range
- Fast power-on time
- Resistant to mechanical stress
- 3-pin SIP and SOT89-3 package are available

APPLICATIONS

- Angular sensing
- Position sensing
- Over-current detection
- BLDC motor current monitoring
- Weigh and liquid level sensing

DESCRIPTION

The SC400X are high performance small versatile linear Hall-Effect devices which are operated by the magnetic field from a permanent magnet or an electromagnet. The radiometric output voltage is set by the supply voltage and varies in proportion to the strength of the magnetic. The quiescent output voltage of the SC4002 and SC4003 is 50% of the supply voltage, and the sensitivity is 3.125mV/Gs and 5.0mV/Gs and 2.5mV/GS respectively.

The SC4002/SC4003/SC4005 provide low-noise output with temperature compensation. The linear position sensor ICs have an operating temperature range of -40°C to 150°C, appropriate for industrial environments These devices are available in a 3-pin SIP and SOT89 packages. Both packages are lead(Pb) free, with 100% matte tin lead frame plating.



CONTENTS

FEATURES	- 1 -	THERMAL CHARACTERISTICS.....	- 5 -
APPLICATIONS.....	- 1 -	OPERATING CHARACTERISTICS.....	- 6 -
DESCRIPTION	- 1 -	TYPICAL APPLICATION.....	- 7 -
BLOCK DIAGRAM	- 3 -	PACKAGE INFORMATION (UA).....	- 8 -
ORDERING INFORMATION.....	- 3 -	PACKAGE INFORMATION (BU).....	- 9 -
TERMINAL CONFIGURATION.....	- 4 -	REVISION HISTORY	- 10 -
ABSOLUTE MAXIMUM RATINGS	- 5 -		
ESD PROTECTION	- 5 -		

BLOCK DIAGRAM

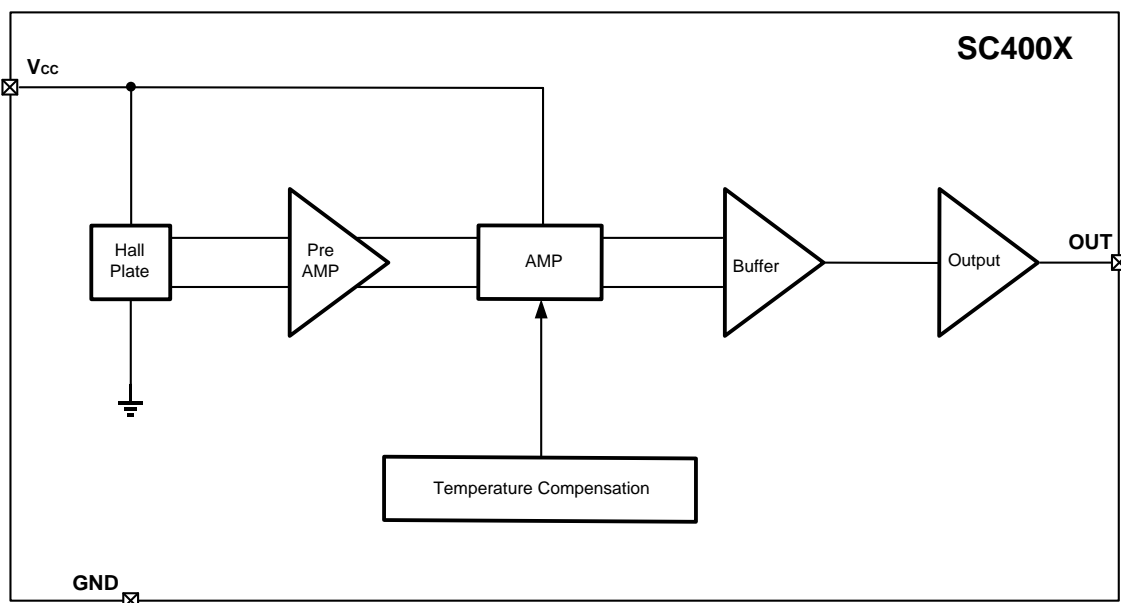

ORDERING INFORMATION

Part Number	Packing	Mounting	Ambient T _A	Marking
SC4002UA	1000 pcs/Bag	SIP3	-40°C to 150°C	4002
SC4002BU	1000 pcs /Reel	3-pin SOT89	-40°C to 150°C	4002
SC4003UA	1000 pcs /Bag	SIP3	-40°C to 150°C	4003
SC4005UA	1000 pcs /Bag	SIP3	-40°C to 150°C	4005

TERMINAL CONFIGURATION

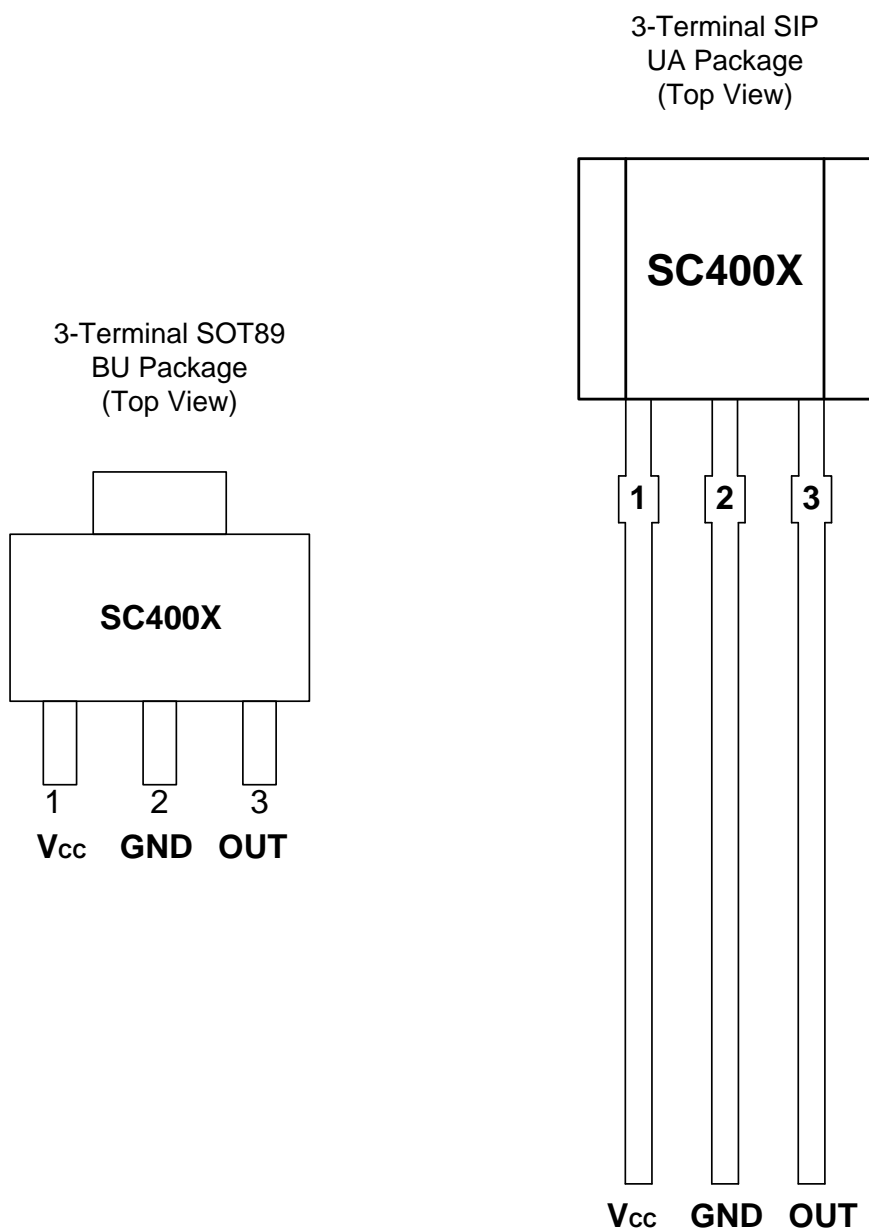

Terminal		Type	Description
Name	Number		
V _{CC}	1	PWR	3.5V ~ 10.5 V power supply
GND	2	Ground	Ground terminal
OUT	3	Output	Output terminal

ABSOLUTE MAXIMUM RATINGS

over operating free-air temperature range

Parameter	Symbol	Min.	Max.	Units
Power supply voltage	V_{CC}	-0.5	30.0	V
Output terminal voltage	V_{OUT}	-0.3	30.0	V
Supply current	I_{CC}	--	20	mA
Output current	I_{OUT}	--	2	mA
Operating ambient temperature	T_A	-40	150	°C
Operating junction temperature	T_J	-50	165	°C
Storage temperature	T_{STG}	-65	175	°C

Note: Stresses above those listed here may cause permanent damage to the device. Exposure to absolute maximum rating conditions for extended periods may affect device reliability.

ESD PROTECTION

Human Body Model (HBM) tests according to: standard AEC-Q100-002

Parameter	Symbol	Min.	Max.	Units
HBM ESD stress voltage	V_{ESD}	-4000	4000	V

THERMAL CHARACTERISTICS

Parameter	Symbol	Test Conditions	Rating	Units
Package thermal resistance	$R_{\theta JA}$	Single-layer PCB, with copper limited to solder pads	166	°C/W

OPERATING CHARACTERISTICS

over operating free-air temperature range ($V_{CC}=5V$, unless otherwise noted)

Parameter	Symbol	Test Conditions	Min.	Typ.	Max.	Units
Supply voltage	V_{CC}	$T_J < T_{J(Max)}$	3.5	5.0	10.5	V
Supply current	I_{CC}	$V_{CC}=5.0V, T_A=25^\circ C$	--	4.5	10.0	mA
Output load resistance	R_L	OUT to VCC	2	--	--	k Ω
		OUT to GND	2	--	--	
Output voltage range	$V_{OUT(H)}$	$T_A=25^\circ C, B=1000Gs$	4.8	4.9	--	V
	$V_{OUT(L)}$	$T_A=25^\circ C, B=-1000Gs$	--	0.1	0.2	V
Quiescent voltage output	$V_{OUT(Q)}$	$B=0 Gs, T_A=25^\circ C$	2.3	2.5	2.7	V
Sensitivity	Sens	SC4002, $T_A=25^\circ C$	2.75	3.125	3.5	mV/Gs
		SC4003, $T_A=25^\circ C$	4.0	5.0	6.0	
		SC4005, $T_A=25^\circ C$	2.0	2.5	3.0	
Linearity	Lin		-1--	--	+1	%
Delta sensitivity vs. temp.	$\Delta Sens$	$T_A = -40^\circ C$ to $105^\circ C$	-10--	--	+10	%
Step response time	t_{resp}	Delay the output signal reaching 90%	--	1	--	μS

1Gs = 0.1mT

TYPICAL APPLICATION

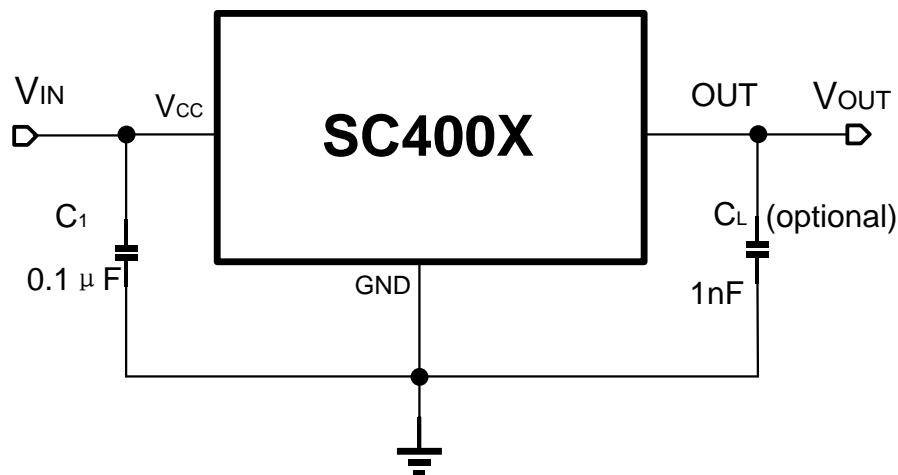

In the quiescent state (that is, with no significant magnetic field: $B=0$), the output, $V_{OUT(Q)}$, equals to half of the supply voltage, V_{CC} , throughout the entire operating range of V_{CC} . The presence of a South-polarity magnetic field perpendicular to the branded surface of the package increases the output voltage from its quiescent value toward the supply voltage rail. The amount of the output voltage increase is proportional to the magnitude of the magnetic field applied. Conversely, the application of a North polarity field will decrease the output voltage from its quiescent value. The device has three magnetic sensitivity options, 3.125mV/Gs, 5.0mV/Gs, and 2.5 mV/Gs.

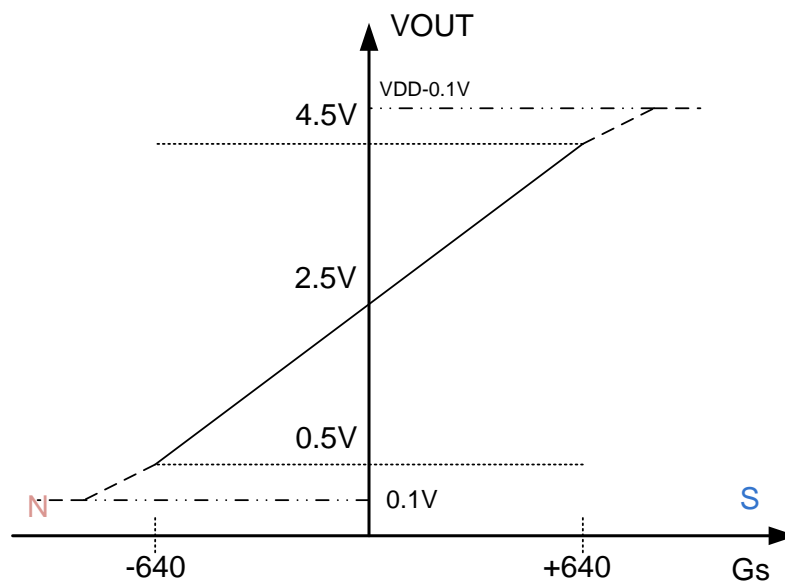

PACKAGE INFORMATION (UA)

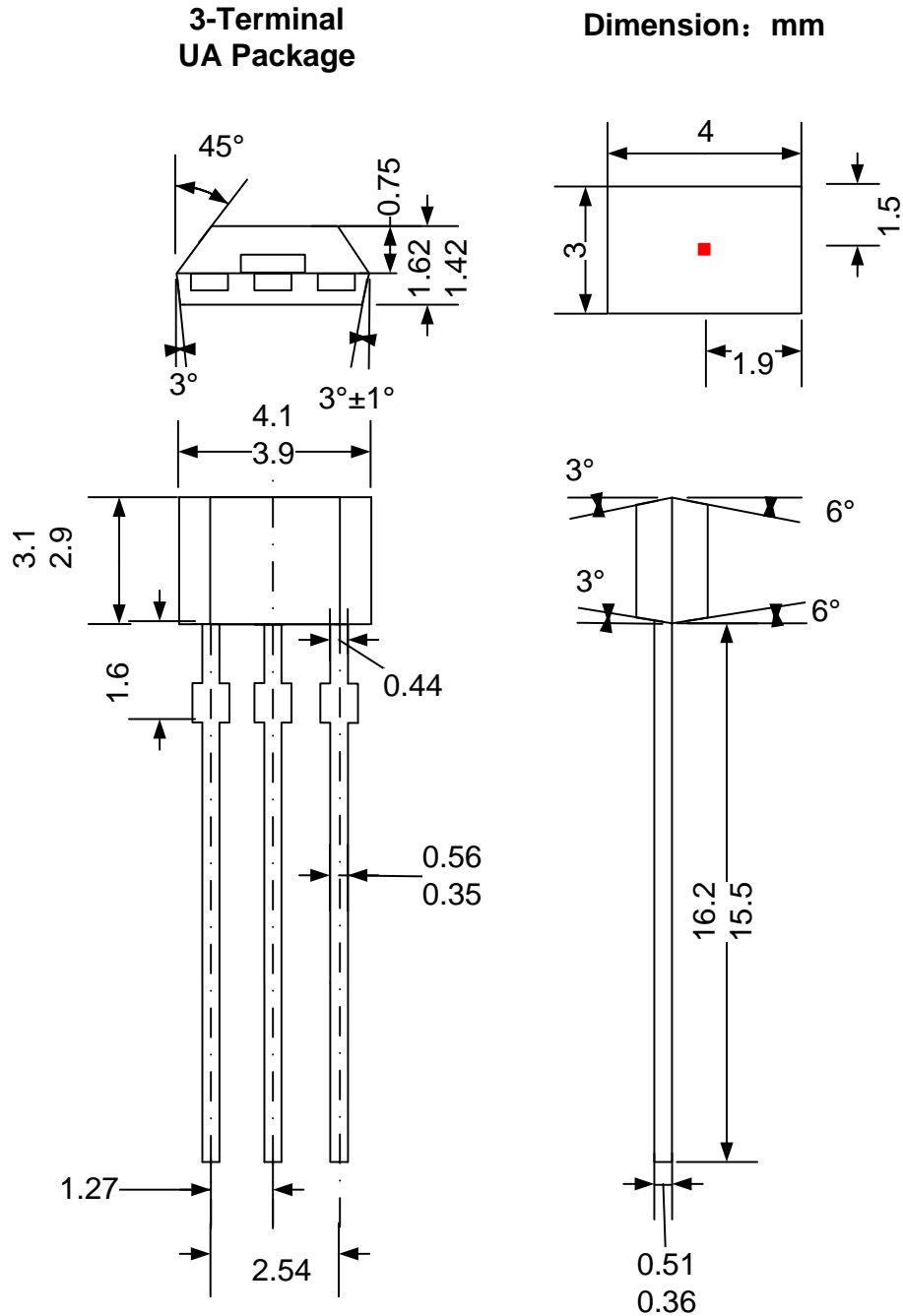

Notes:

1. Exact body and lead configuration at vendor's option within limits shown.
2. Height does not include mold gate flash.

Where no tolerance is specified, dimension is nominal.

PACKAGE INFORMATION (BU)

3-Terminal BU Package

Dimension: mm

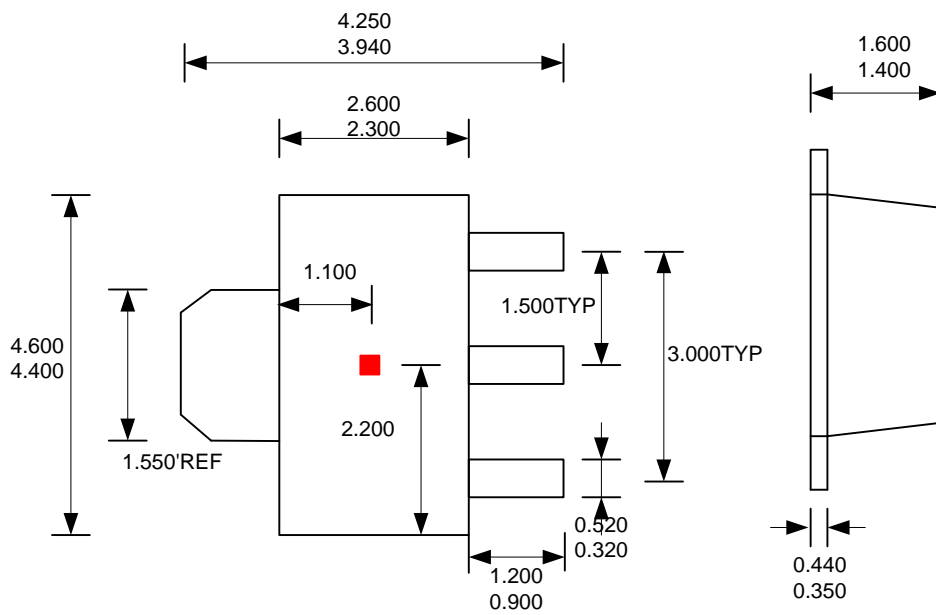

Notes:

1. Exact body and lead configuration at vendor's option within limits shown.
2. Height does not include mold gate flash.

Where no tolerance is specified, dimension is nominal.

REVISION HISTORY

Revision	Date	Description
Rev1.0	2017-06-15	Preliminary Datasheet
Rev2.0	2018-05-06	Add order information of SC4002BU
Rev2.3	2019-07-06	The final revision of old datasheet
RevA/1.0	2020-11-19	Unified datasheet format