

INFRARED REMOTE CONTROL TRANSMITTER OF NEC CODE FORMAT

DESCRIPTION

The SC6121 is a remote control transmitter utilizing CMOS Technology specially designed for use on infrared remote control applications. It is capable of controlling 32 function keys and 3 double keys. SC6121 is housed in a 20-pins SOP package.

FEATURES

- * Low power dissipation (quiescent current $< 1\mu\text{A}$)
- * Operating frequency is 455KHz, output carrier frequency is 38KHz
- * Use PPM (Pulse phase modulation) coding format
- * Low Operating Voltage ($V_{DD}=2.0\sim 5.5\text{V}$)
- * Using SEL pin, SC6121 can support 64+6 function codes
- * Customer Code can be selected

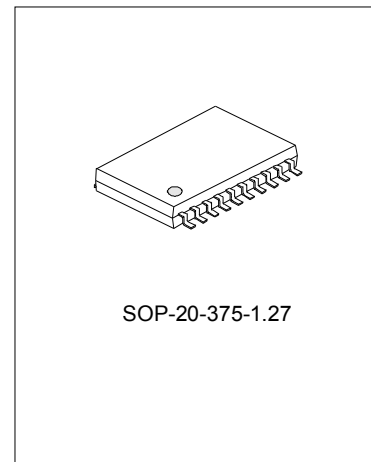

APPLICATIONS

- * TV and VCR
- * Audio Equipment
- * Cable TV Tuner
- * Cassette Deck
- * Air Conditioner
- * VCD and DVD ROM/Player
- * Moniputer/Multi-Media Personal Computer System

ORDERING INFORMATION

SC6121-001	ROM content=0
SC6121-002	Custom version

BLOCK DIAGRAM

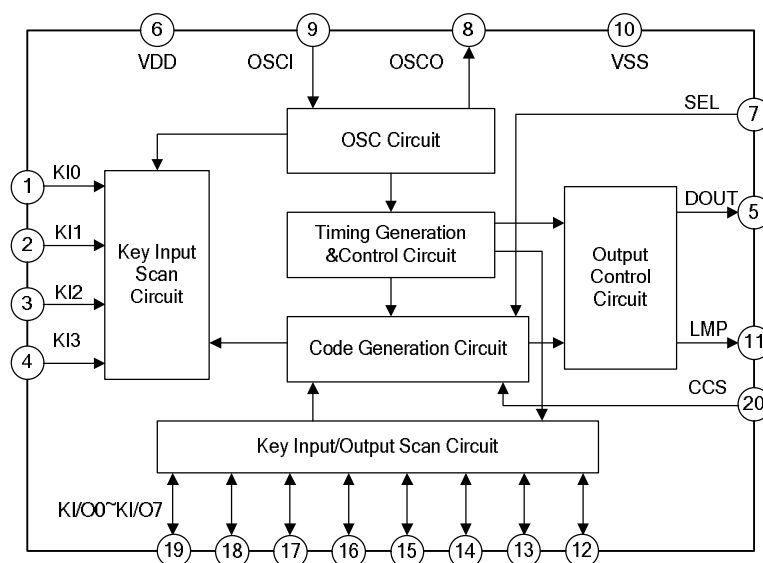

ABSOLUTE MAXIMUM RATING ($T_{amb}=25^{\circ}C$, unless otherwise specified)

Characteristics	Symbol	Value	Unit
Supply Voltage	V _{DD}	6.0	V
Input Voltage	V _{IN}	-0.3~V _{DD}	V
Power Dissipation	P _d	250	mW
Storage Temperature	T _{stg}	-40~+125	°C
Operating Temperature	T _{opr}	-20~+75	°C

RECOMMENDED OPERATING CONDITIONS ($T_{amb}=25^{\circ}C$, unless otherwise specified)

Characteristics	Symbol	Min.	Typ.	Max.	Unit
Supply Voltage	V _{DD}	2.0	3.0	3.3	V
Oscillation Frequency	f _{osc}	400	455	500	KHz
Input Voltage	V _{IN}	0	--	V _{DD}	V
Custom Code Select Pull-Up Resistance	R _{up}	--	100	--	K Ω

ELECTRICAL CHARACTERISTICS ($T_{amb}=25^{\circ}C$, V_{DD}=3.0V, unless otherwise specified)

Characteristics	Symbol	Test conditions	Min.	Typ.	Max.	Unit
Supply Voltage	V _{DD}		2.0	3.0	5.5	V
Current Consumption 1	I _{DD1}	F _{osc} =455KHz		0.1	1.0	mA
Current Consumption 2	I _{DD2}	F _{osc} =STOP			1.0	μ A
REM High Level Output Current	I _{OH1}	V _o =1.5V	-5.0	-8.0		mA
REM Low Level Output Current	I _{OL1}	V _o =0.3V	15	30		μ A
LMP High Level Output Current	I _{OH2}	V _o =2.7V	-15	-30		μ A
LMP Low Level Output Current	I _{OL2}	V _o =0.3V	1	1.5		mA
KI High Level Input Current	I _{IH1}	V _{IN} =3.0V	5		30	μ A
KI Low Level Input Current	I _{IL1}	V _{IN} =0V			-0.2	μ A
KI High Level Input Voltage	V _{IH1}		0.7 V _{DD}		V _{DD}	V
KI Low Level Input Voltage	V _{IL1}		0		0.3 V _{DD}	V
KI/O High Level Input Voltage	V _{IH2}		0.7 V _{DD}		V _{DD}	V
KI/O Low Level Input Voltage	V _{IL2}		0		0.4	V
KI/O High Level Input Current	I _{IH2}	V _{IN} =3.0V	2		7	μ A
KI/O Low Level Input Current	I _{IL2}	V _{IN} =0V			-0.2	μ A
KI/O High Level Output Current	I _{OH3}	V _o =2.5V	0.5		1.5	mA
KI/O Low Level Output Current	I _{OL3}	V _o =1.7V	1.5		2.5	mA
CCS Low Level Input Voltage	V _{IH3}		1.1			V
CCS High Level Input Current	I _{IH3}	Pull Up V _{IN} =3.0V			0.2	μ A
CCS Low Level Input Current	I _{IL3}	Pull Up V _{IN} =0V	-3		-15	μ A
CCS High Level Input Current	I _{IH4}	Pull Down V _{IN} =3.0V	5		30	μ A
CCS Low Level Input Current	I _{IL4}	Pull Down V _{IN} =0V			-0.2	μ A

PIN CONFIGURATION

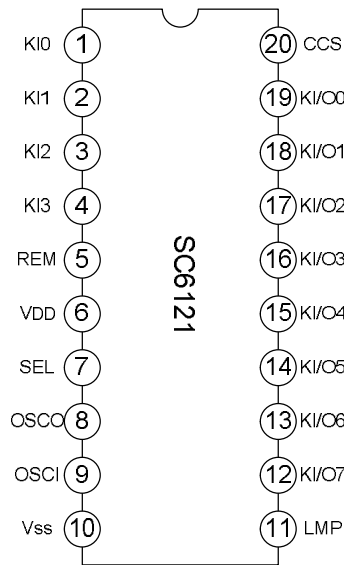

PIN DESCRIPTION

Pin No.	Symbol	I/O	Description
1~4	K10~K13	I	Key Input Pin Nos. 0~3
5	REM	O	Data Output Pin
6	VDD	--	Power Supply
7	SEL	I	Select Pin, SEL is the data selection of D7
8	OSCO	O	Oscillator Pin
9	OSCI	I	Oscillator Pin
10	Vss	--	Power Supply
11	LMP	O	Output LED Indicator, low active.
19~12	K1/O0~K1/O7	I/O	Key Input/Output Pin Nos.0~7
20	CCS	I	CCS is the scan input of the low 8-bit custom code

FUNCTIONAL DESCRIPTION

1. TRANSMISSION CODE

The transmission code consists of a leader code, 16-bits custom codes, and 8-bits data codes. The inverse code of the data code is also sent simultaneously. The following diagram shows this one frame construction.

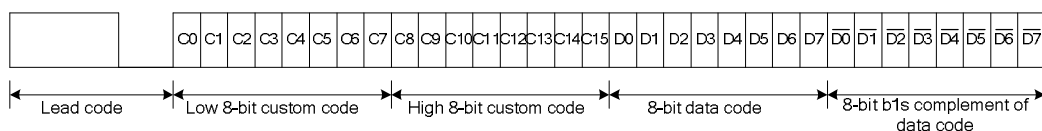

The leader codes consist of a 9ms carrier waveform followed by a 4.5ms OFF waveform. It is used as the leader for the following code. Thus, when reception is configured by a microcomputer, the time relationship between the reception detection and other processes can be managed efficiently. The code uses the PPM (Pulse

Position Modulation) Method, with "0" and "1" differentiated by the time between pulses. Each code consists of 8 bits, and simultaneous transmission of the inverse code allows configuration of a system with an extremely low error rate.

2. KEY INPUT MATRIX

The Key Input Matrix of SC6121 is given below:

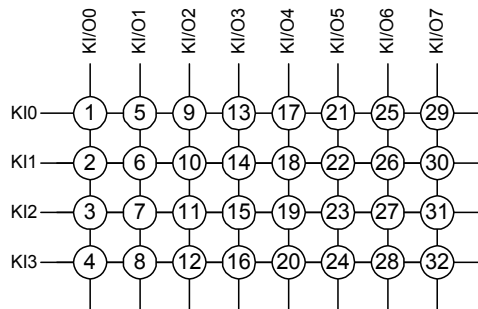

3. Key INPUT

A total of 32 keys can be connected by SC6121 Key Input Pins--KI0~KI3 and the Timing Signal Output Pins KI/O0~KI/O7.

Double Key Operation is possible for only Key No.21 in combination with other keys connected to the KI/O5 line namely: Key No.22,23 or 24.thus, only the following key combinations may be used for the double key operation:

1. Key Nos.21 and 22
2. Key Nos.21 and 23
3. Key Nos.21 and 24

Pull-down resistors are connected between the Key Input and Vss Pins. When more than one key (except the double key) are pressed simultaneously, the transmission output stops.

Two key inputs are regarded as being pressed simultaneously when the time interval between these two key entries is less than 36ms.

The order of priority given to two key inputs with a time interval of more than 36ms is on a First-Pressed-First-Served or Longer-Pressed-First-Served Basis.

When a key is pressed, the custom and data codes are read. 36ms later, the Remote (REM) Output is activated. When the key is kept depressed during this 36ms, one transmission is outputted. If the key is depressed for more than 108ms, then the only the leader code is transmitted continuously.

4. DOUBLE KEY OPERATION

Double Key Operation is useful for operations such as tape deck recording. The following table shows the Key Data corresponding to the double keys pressed. Also refer to the Key Input Section.

The Double Key operation forms are as follows:

Key	D0	D1	D2	D3	D4	D5	D6	D7
K21+K22	1	0	1	0	1	1	0	0/1
K21+K23	0	1	1	0	1	1	0	0/1
K21+K24	1	1	1	0	1	1	0	0/1

Note: D7=1 when SEL is connected to Vss, or D7=0 when SEL is connected to VDD.

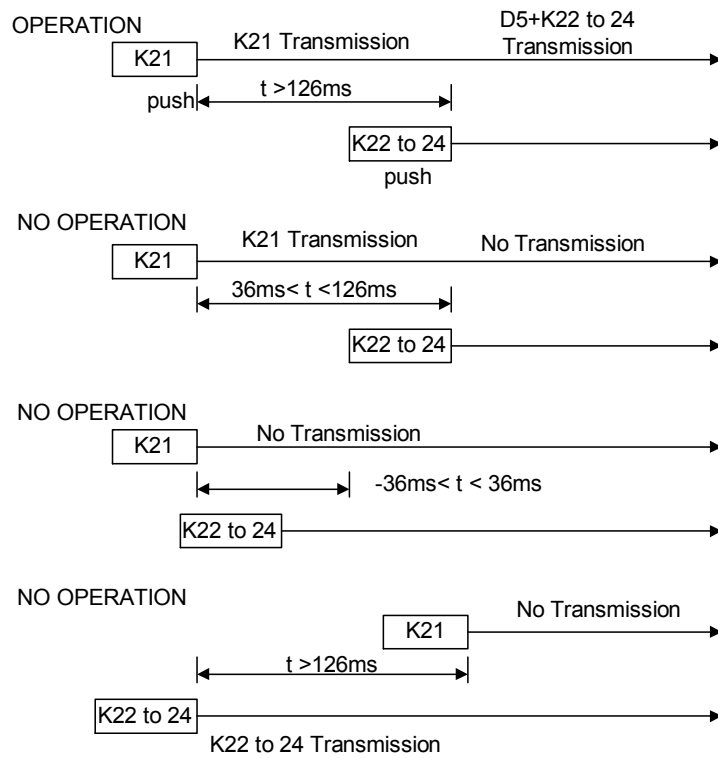

5. REMOTE OUTPUT WAVEFORMS

The Remote Output Waveforms are given in the diagram below:

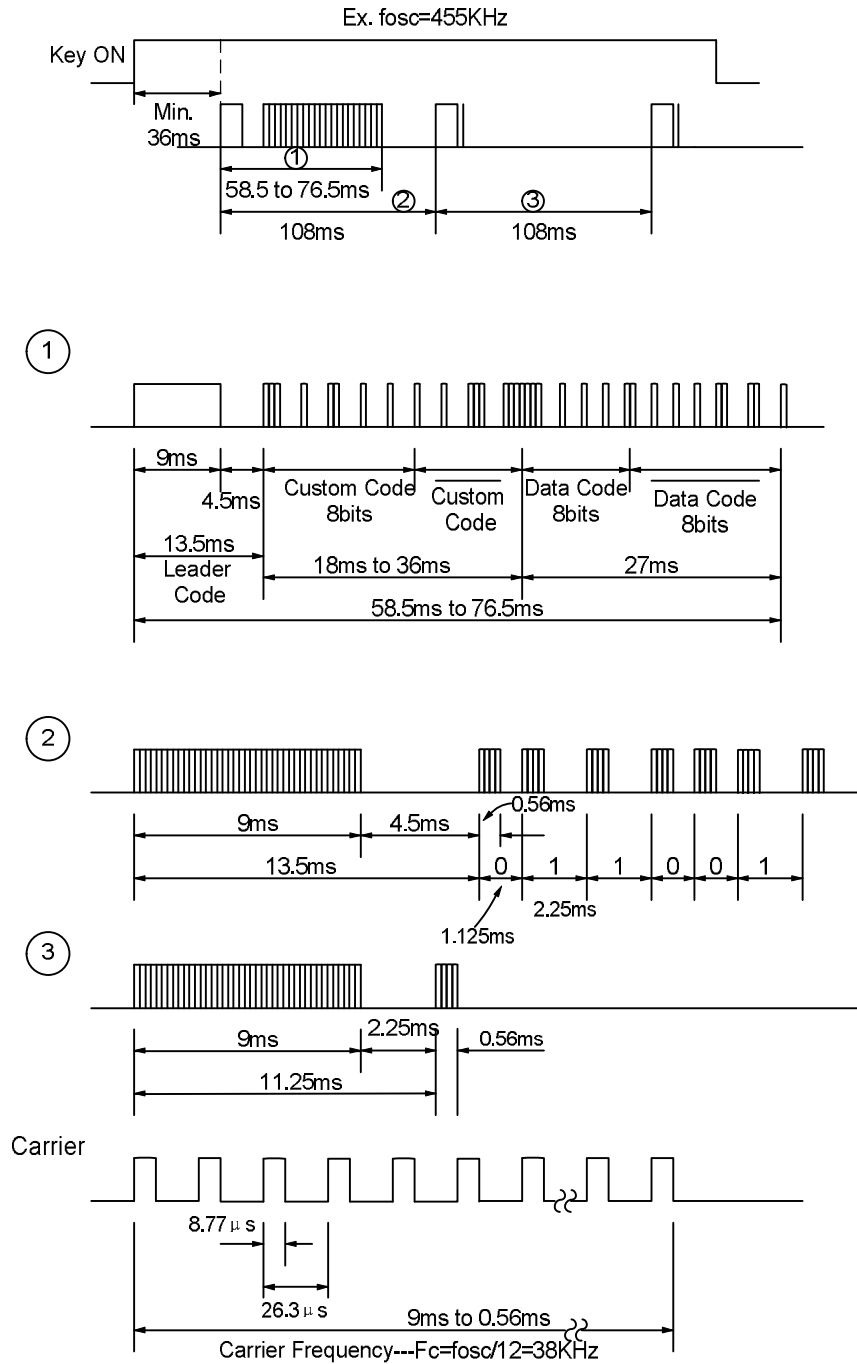

6. Custom code setting

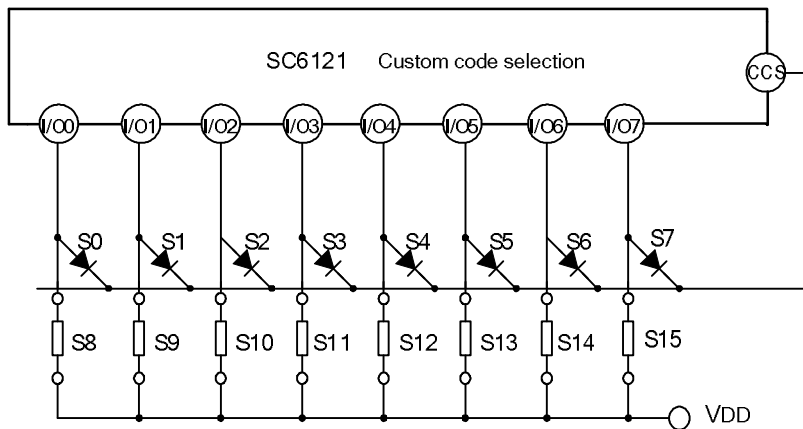

In the above figure, the custom code of SC6121 is determined through the connection of KI/O and CCS. Where, S0~S7 are the status of diode between the KI/O0~ KI/O7 and CCS, 1 means connection, 0 means no connection; S8~S15 are the connect status between KI/O0~ KI/O7 and power, 1 means connection, 0 means no connection; the 16-bit custom code is defined as : C0, C1,C15. There are two code formats: 001 and 002.

➤ 001 code format

C0~C7 are determined through S0~S7; C8~C15 are got through C0~C7 OR S8~S15, refers to the following content: C0=S0, C1=S1, C2=S2, C3=S3, C4=S4, C5=S5, C6=S6, C7=S7;

C8=S8⊙C0, C9=S9⊙C1, C10=S10⊙C2, C11=S11⊙C3, C12=S12⊙C4, C13=S13⊙C5, C14=S14⊙C6, C15=S15⊙C7.

Thus, the 16-bit custom code can be set flexibly, and up to $2^{16}=65536$.

Note: (1) when there is only one KI/O connects with CCS; the diode can be replaced by wire.

(2) The symbol ⊙ means XNOR;

➤ 002 code format

C0~C2 are determined through KI/O0~KI/O7 connects to CCS, as the following table:

KI/On connect to CCS	C2	C1	C0
KI/O0(S0)	0	0	0
KI/O1(S1)	0	0	1
KI/O2(S2)	0	1	0
KI/O3(S3)	0	1	1
KI/O4(S4)	1	0	0
KI/O5(S5)	1	0	1
KI/O6(S6)	1	1	0
KI/O7(S7)	1	1	1

C7~C3 is set through the pull-up resistor connection or not of KI/O6 and KI/O7, as the following table:

Pull-up resistor		C7~C3 in low 8-bit custom code				
KI/O6	KI/O7	C7	C6	C5	C4	C3
No	No	0	0	0	0	0
No	Yes	1	0	0	1	1
Yes	No	1	0	0	0	0
Yes	Yes	1	1	1	0	1

The high 8-bit custom code C8~C15 are determined through C0~C7 OR S8~S13: C8=C0⊕S8, C9=C1⊕S9, C10=C2⊕S10, C11=C3⊕S11, C12=C4⊕S12, C13=C5⊕S13, C14=C6⊕0, C15=C7⊕0.

In this version, not all the custom code can be set.

7. Continuous transmission mode

When REM connects with any KI port through diode, all the keys have continuous transmission function; when REM connects with one KIO port, this port has continuous transmission function. In this transmission mode, the power dissipation is larger. For example, if the REM connects with KIO0 through a diode, the keys in the KIO0 (#1, #2, #3, #4, #33, #34, #35, #36) will be all transmitted.



Connecting mode

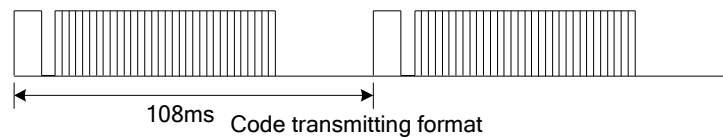

Note: (1) the double-key is invalid in continuous transmission mode;

(2) If the voltage drop of REM is too heavy, the signal won't transmit correctly, thus we shall control the REM output current.

8. SC6121 KEYS DATA CODE

The Keys Data Code is given in the table below.

Key No.	Connection				KI/O	Data Code							
	KI0	KI1	KI2	KI3		D0	D1	D2	D3	D4	D5	D6	D7
K1	•				KI/O0	0	0	0	0	0	0	0	0/1
K2		•				1	0	0	0	0	0	0	0/1
K3			•			0	1	0	0	0	0	0	0/1
K4				•		1	1	0	0	0	0	0	0/1
K5	•				KI/O1	0	0	1	0	0	0	0	0/1
K6		•				1	0	1	0	0	0	0	0/1
K7			•			0	1	1	0	0	0	0	0/1
K8				•		1	1	1	0	0	0	0	0/1
K9	•				KI/O2	0	0	0	1	0	0	0	0/1
K10		•				1	0	0	1	0	0	0	0/1
K11			•			0	1	0	1	0	0	0	0/1
K12				•		1	1	0	1	0	0	0	0/1
K13	•				KI/O3	0	0	1	1	0	0	0	0/1
K14		•				1	0	1	1	0	0	0	0/1
K15			•			0	1	1	1	0	0	0	0/1
K16				•		1	1	1	1	0	0	0	0/1
K17	•				KI/O4	0	0	0	0	1	0	0	0/1
K18		•				1	0	0	0	1	0	0	0/1
K19			•			0	1	0	0	1	0	0	0/1
K20				•		1	1	0	0	1	0	0	0/1
K21	•				KI/O5	0	0	1	0	1	0	0	0/1
K22		•				1	0	1	0	1	0	0	0/1
K23			•			0	1	1	0	1	0	0	0/1
K24				•		1	1	1	0	1	0	0	0/1
K25	•				KI/O6	0	0	0	1	1	0	0	0/1
K26		•				1	0	0	1	1	0	0	0/1
K27			•			0	1	0	1	1	0	0	0/1
K28				•		1	1	0	1	1	0	0	0/1
K29	•				KI/O7	0	0	1	1	1	0	0	0/1
K30		•				1	0	1	1	1	0	0	0/1
K31			•			0	1	1	1	1	0	0	0/1
K32				•		1	1	1	1	1	0	0	0/1

 Note: D7=1 when SEL is connected to V_{SS}, or D7=0 when SEL is connected to V_{DD}.

TYPICAL APPLICATION CIRCUIT

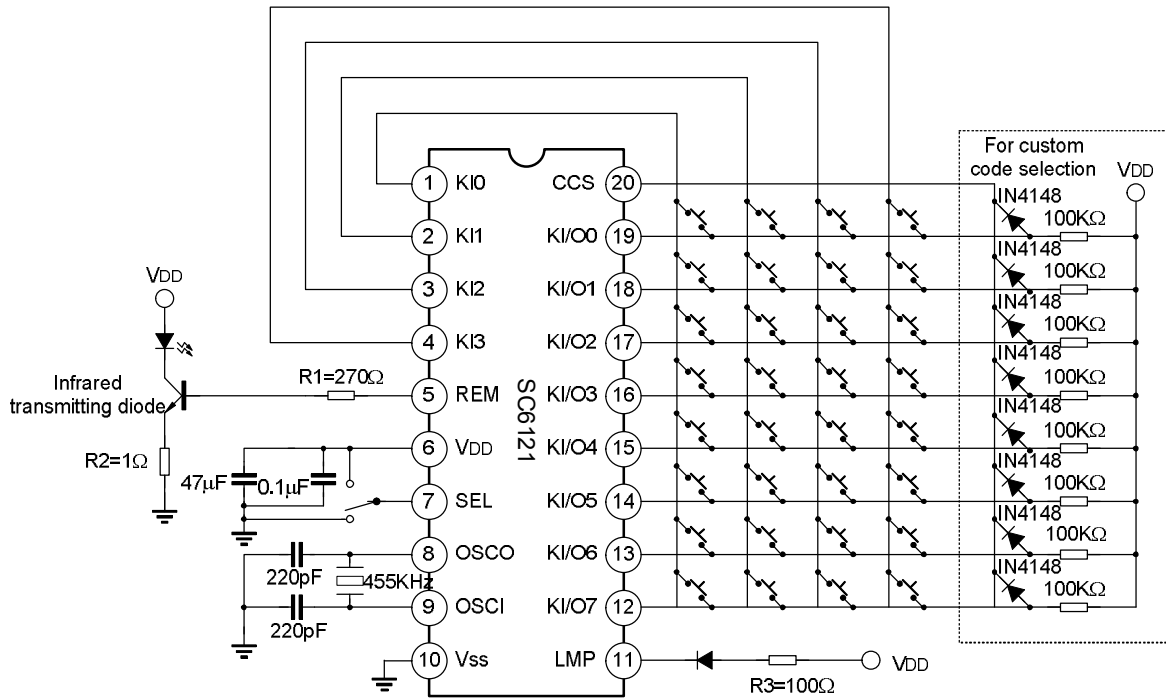

- Note: 1. Two capacitance connect with Vcc should as near as possible.
 2. The line between two capacitance and Vcc and ground should as short as possible.

PCB WIRE LAYOUT SCHEMATIC

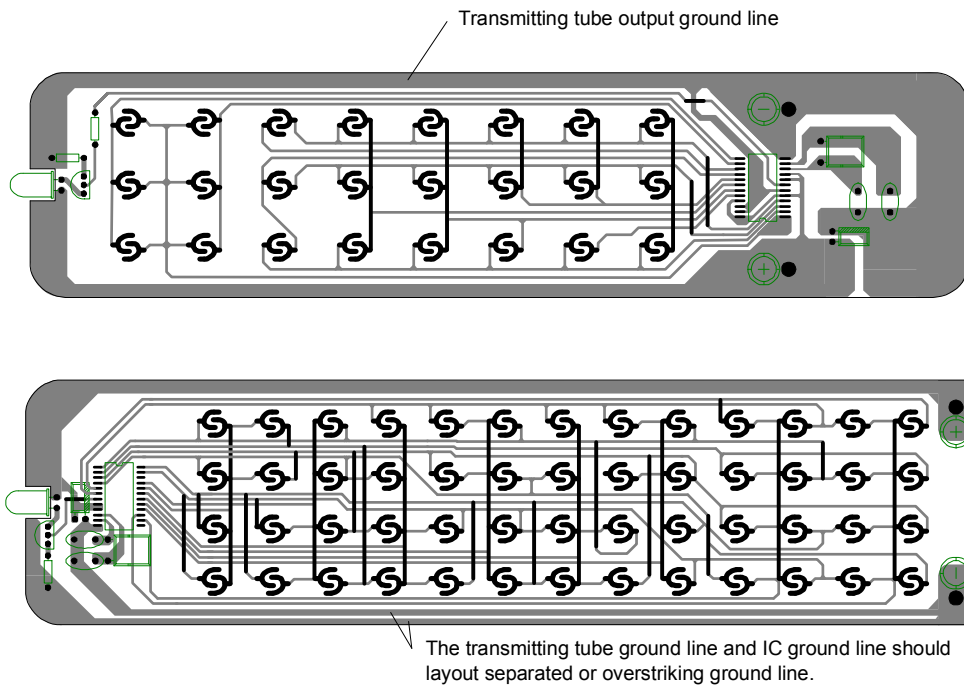

The above IC only use to hint, not to specified.

Note:

- * In wire layout, the power filter capacitor should near to IC.
- * In wire layout, should avoid power line and ground line too long.
- * Recommended infrared transmit unit and IC ground line should layout separated, or overlapping lines.
- * The emitter of triode connect 1Ω resistor at least.
- * Recommended triode use 9014.

PACKAGE OUTLINE

SOP-20-375-1.27

UNIT: mm

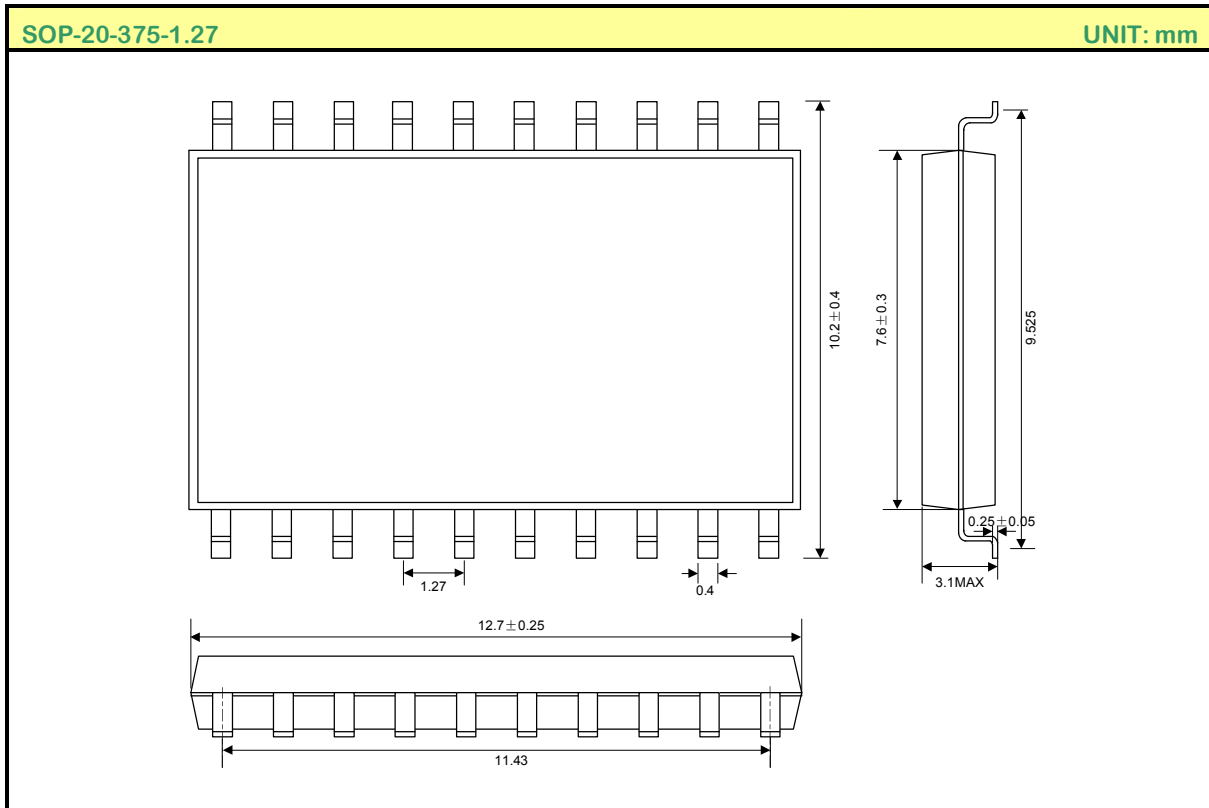

HANDLING MOS DEVICES:

Electrostatic charges can exist in many things. All of our MOS devices are internally protected against electrostatic discharge but they can be damaged if the following precautions are not taken:

- Persons at a work bench should be earthed via a wrist strap.
- Equipment cases should be earthed.
- All tools used during assembly, including soldering tools and solder baths, must be earthed.
- MOS devices should be packed for dispatch in antistatic/conductive containers.

Note: Silan reserves the right to make changes without notice in this specification for the improvement of the design and performance. Silan will supply the best possible product for customers.

ATTACHMENT

Revision History

Data	REV	Description	Page
2001.12.12	1.1		
2002.02.28	1.2	Modify the "Typical application circuit"	8
		Add the "PCB wire layout schematic"	9
		Modify the "Package outline"	10
2008.04.02	1.3	Add the "custom code setting" and "Continuous transmission mode"	