

Up to 200A, Full automatic encapsulation assembly, Isolated Current Sensor

Description:

The SC780 is a Vicorv integrated current sensor product line, the industry's first fully automatic plastic seal assembly of fully integrated current detection module, the industry's first from chip design to module assembly process development of fully autonomous and controlled open-loop Hall-type current sensor module.

This product enables current conductor impedance as low as $0.08\text{m}\Omega$ in the semiconductor sealing process, making it suitable for use in power systems that require continuous operation in measuring up to 200A, with the integration of low impedance side conductors, low hysteresis cores and self-developed linear Hall IC.

The SC780 Vicorv are isolated current detection chips that operate on the principle of open-loop Hall sensor detection. By introducing high side current conductor encapsulated in the body, based on the magnetic current, amount of geometric magnetic field generated around the conductor to be tested by core polymerization, the built-in chip magnetic sensor after induction, converted to can handle the geometric voltage signals, the voltage signal through the built-in high resolution ADC read amplifier, with digital calibration techniques, to get rid of such as temperature, noise, hysteresis and nonlinearity of environment variables, such as the final output and the measured current value into an almost ideal than voltage value, realize the isolation type current measurements.

SC780 adopts automatic production and processing, can bring customers incomparable consistency, high quality and high reliability of module technology. The product can be used for AC or DC current measurement, used in UPS, charging piles, frequency converters, white goods and other industrial, commercial and communication systems.

Features

- 5 kV RMS minimum isolation voltage
- Can measure DC and AC current
- Lowest Current conductor impedance : $0.08\text{m}\Omega$
- 20kA 8/20uS surge current bearing capacity
- Response time as low as 4uS
- Optional unidirectional current detection mode
- Wide operation temp. range:-40°C~125°C
- Wide range of measured current :50A~280A
- Total output error <1% @TA =25°C, <3% for full temperature range.
- Strong driving ability, support the output port to connect to the load as low as 2k
- Extremely simple peripheral circuit
- It is not interfered by wire magnetic field, external magnetic field and geomagnetic field
- High PSRR
- From chip to assembly, independent research and development, no technical dependence



Package Type

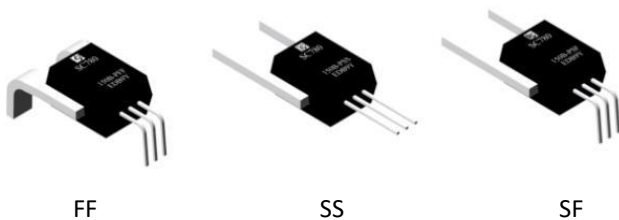

Package

Top View:



Inside view:

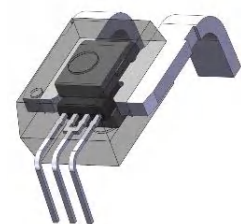

Typical Application

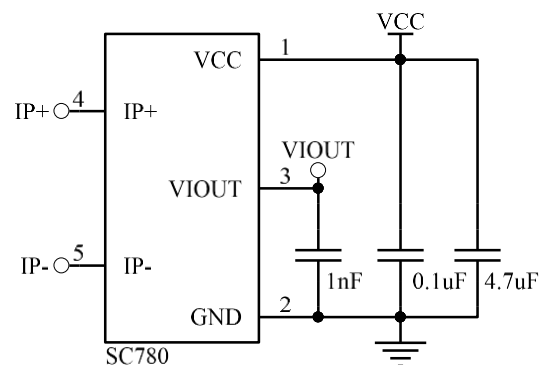

Note: 4.7uF power filter capacitors must be used to ensure performance

Order information

Part Number	Temp Range (°C)	IP(A)	Vout* ¹ @IP=0A(V)	Packaging	Number of packages	Sens* ² @ VCC=5V (mV/A)
SC780-050B-PFF	-40 to 125	±50	B(0.5Vcc)	PFF	40 PCs/pipe 20pipes/package	40
SC780-100B-PFF		±100	B(0.5Vcc)			20
SC780-150B-PFF		±150	B(0.5Vcc)			13.33
SC780-200B-PFF	-40 to 85	±200	B(0.5Vcc)			10
SC780-250B-PFF		±250	B(0.5Vcc)			8
SC780-280B-PFF		±280	B(0.5Vcc)			7.14
SC780-050U-PFF	-40 to 125	50	U(0.1Vcc)			80
SC780-100U-PFF		100	U(0.1Vcc)			40
SC780-150U-PFF		150	U(0.1Vcc)			26.66
SC780-200U-PFF	-40 to 85	200	U(0.1Vcc)			20

Note1: B and U types are different in the reference output when IP=0A, and B is recommended by default.

B	When IP=0A, VIOU@0A=0.5*VCC, suitable for bidirectional current detection, Zero Current Output and sensitivity vary with VCC ratio.
U*2	When IP=0A, VIOU@0A=0.1*VCC, suitable for unidirectional current detection, Zero Current Output and sensitivity vary with VCC ratio.

Note 2: Model U, dynamic range x2 sensitivity x2; if there is any other sensitivity requirement, can connect our FAE or agent.

Pin Configuration

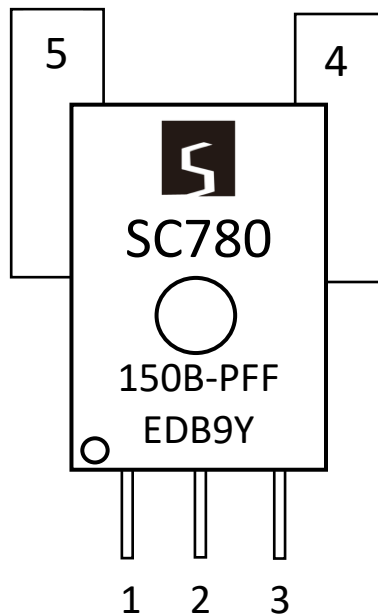

Number	Name	Description
1	VCC	Device power supply terminal, default 5V
2	GND	Signal Ground terminal
3	VIOU	Analog output signal, VIOU=IP*Sens+ VIout @ IP=0A
4	IP+	Primary current input positive terminal
5	IP-	Primary current input negative terminal

Thermal Rise vs. Primary Current

Typical junction temperature [°C] of SC780 vs Primary current [A] based on Demo Board

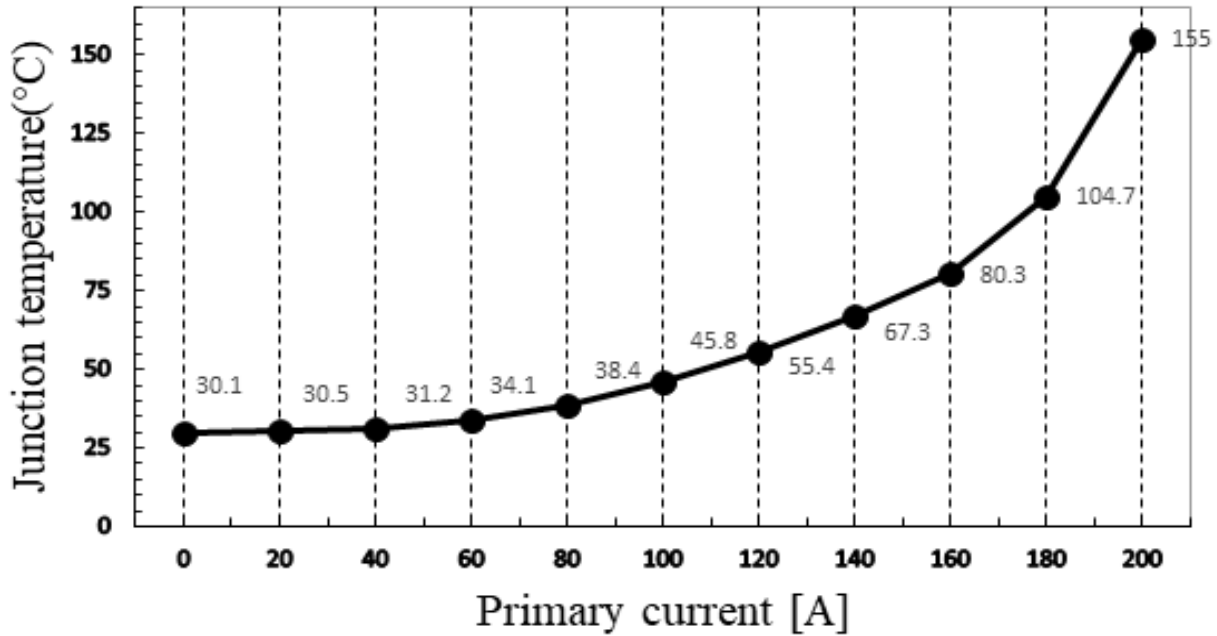

Note: for >100A application, please pay attention to the current line layout of the PCB board and its conductor impedance and heat dissipation capacity

Demo Board information

	DEMO	Units
The layer number of PCB	2	
Single layer copper-clad PCB thickness	4	Oz
Area of copper sheet connected to original edge pin (including all layers)	4581	mm ²
Board Thickness	1.6	mm

Functional Block Diagram

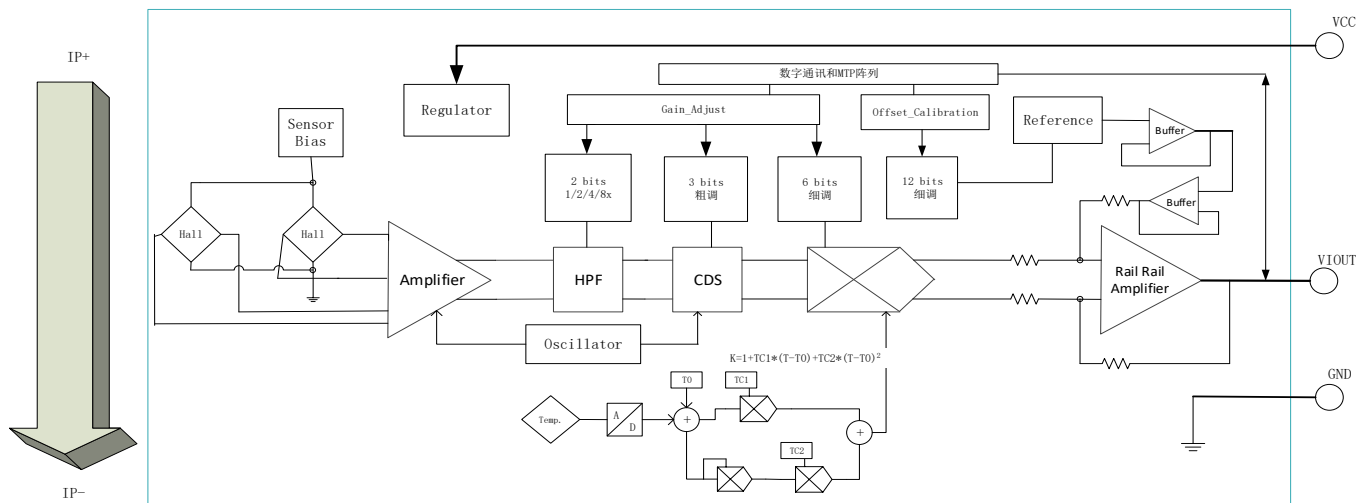

Absolute Maximum Ratings

Absolute maximum ratings are limiting values to be applied individually, and beyond which the serviceability of the circuit may be impaired. Exposure to absolute maximum rating conditions for an extended period of time may affect device reliability.

Symbol	Characteristic	Notes	Rating	Unit
V _{CC}	Supply voltage		6.0	V
V _{RCC}	Reverse Supply Voltage		-0.1	V
V _{IOUT}	Output voltage		6.0	V
V _{RIOUT}	Reverse Output Voltage		-0.1	V
T _A	Nominal Operating Ambient Temperature	F range	-40~125	°C
		E range	-40~85	
T _{J(max)}	Maximum Junction Temperature		165	°C
T _{stg}	Nominal Operating Ambient Temperature		-65~165	°C
I _{OUT(Source)}	Output Current Source	Shorted Output-to-Ground Current	4	mA
I _{OUT(Sink)}	Output Current Sink	Shorted Output-to-VCC Current	67	mA
IP _{max}	Maximum IP value of sustainable loading at ambient temperature	It is directly related to the heat dissipation capacity of PCB, and this data depends on the demo test board	200	A
IP _{over}	Transient overload IP value of sustainable loading at ambient temperature	It is directly related to the heat dissipation capacity of PCB, and this data depends on the demo test board . 1pulse,100ms,1% duty cycle	1000	A
ESD	HBM mode		4	kV

Isolation Characteristics

Symbol	Parameter	Comment	Value	Unit
V _{ISO}	RMS voltage for AC insulation test,50Hz,1min	Agency type-tested for 60 seconds per UL60950-1	5000	Vrms
V _{WVRI}	Working Voltage for Basic Isolation	Maximum working voltage according to UL60950-1	990	V _{Peak}
D _{cl}	Clearance	Minimum distance through air from IP leads to signal leads	7.25	mm
D _{cr}	Creepage distance	Minimum distance along package body from IP leads to signal leads	7.25	mm
CTI	Leakage mark index	the electrical breakdown (tracking) properties of an insulating material	600	V
Impulse Voltage	1.2/50μs Impulse voltage		10	kV
Impact of Current	8/20μs impulse current		20	kA

Reference application Specification

Symbol	Description	Min	Typ	Max	Unit
C _{VCC2}	The filter capacitor of power supply is connected between VCC and GND	2.2	4.7	--	uF
C _{VCC1}	The filter capacitor of power supply is connected between VCC and GND	0	0.1	--	uF
C _{V_IOUT}	The filter capacitor of Output is connected between Vout and GND	1	1	1.5	nF

Common Electrical Characteristics

Note: Over full range of $T_A=25^{\circ}\text{C}$, $C_{\text{Bypass}}=4.7+0.1\mu\text{F}$, $C_{\text{Load}}=1.0\text{nF}$, $V_{\text{CC}}=5\text{V}$, unless otherwise specified.

Characteristic	Symbol	Test Conditions	Min	Typ	Max	Unit
Supply Voltage	V_{CC}	Operating	4.5	5	5.5	V
Supply Current	I_{CC}	$V_{\text{CC}} = 4.5\sim 5.5\text{V}$, output open		12		mA
Output Capacitance Load	C_{L}	V_{IOUT} to GND	1	1	1.5	nF
Output Resistive Load	R_{L}	V_{IOUT} to GND	5			k Ω
Primary Conductor Resistance	R_{PRIMARY}	$T_A = 25^{\circ}\text{C}$		0.08		m Ω
Temperature Coefficient of Primary Conductor Resistance	TC_R	$T_A=-40\sim 125^{\circ}\text{C}$		3274.12		ppm/ $^{\circ}\text{C}$
Hysteresis	V_{hys}	$V_{\text{iout}}(\text{load } +50\text{A and return to } 0\text{A}) - V_{\text{iout}}(\text{load } -50\text{A and return to } 0\text{A})$		1		mV
Rise time	t_r	IP=50A		2.88		μs
Propagation Delay	t_{pd}	IP=50A		1.88		μs
Response Time	t_{response}	IP=50A		3.64		μs
Bandwidth	f	Small signal-3 dB,		80		kHz
Noise Density	I_{ND}	$T_A = 25^{\circ}\text{C}$, $C_{\text{L}}=1\text{nF}$		1654		$\mu\text{A}(\text{rms})/\sqrt{\text{Hz}}$
Noise	I_{N}			0.133		mA(rms)
	I_{N}	BW=10KHz		0.051		mA(rms)
	I_{N}	BW=1KHz		0.027		mA(rms)
Proportional coefficient of servo sensitivity(suitable for product with suffix B5)	S_{coef}	$V_{\text{CC}}=4.5\sim 5.5\text{V}$, $S_{\text{coef}}=\text{Sens}(V_{\text{CC}}) / \text{Sens}(5\text{V})$		$V_{\text{CC}}/5$		
VIOUT LinearRail to Rail Output Range	Vrail-rail	$R_{\text{L}}=4.7\text{k}\Omega$	10		90	%VCC
Power-On Time	t_{PO}	Output reaches steady state level, $T_J = 25^{\circ}\text{C}$		100	200	μs

SC780-050U Individual Performance Characteristics

Note: Over full range of $T_A = -40 \sim 125^\circ\text{C}$, $C_{\text{Bypass}} = 4.7 + 0.1 \mu\text{F}$, $C_{\text{Load}} = 1.0 \text{ nF}$, $V_{\text{CC}} = 5\text{V}$, unless otherwise specified.

Characteristic	Symbol	Test Conditions	Min	Typ ^[1]	Max	Unit
NOMINAL PERFORMANCE						
Current-Sensing Range	I_{PR}		0		50	A
Zero-Current Output Voltage	V_{OQ}	$I_{\text{P}} = 0\text{A}$		$0.1V_{\text{CC}}$		V
Sensitivity	S_{ENS}	$0\text{A} < I_{\text{P}} < 50\text{A}$		$80 * S_{\text{COEF}}$		mV/A
TOTAL OUTPUT ERROR COMPONENTS: $E_{\text{TOT}} = E_{\text{SENS}} + V_{\text{OE}} / (S_{\text{ENS}} \times I_{\text{P}})$						
Sensitivity Error	E_{SENS}	$I_{\text{P}} = 50\text{A}$, $T_A = 25^\circ\text{C}$	-2		2	%
		$I_{\text{P}} = 50\text{A}$, $T_A = 25 \sim 125^\circ\text{C}$	-4.7		4.7	%
		$I_{\text{P}} = 50\text{A}$, $T_A = -40 \sim 25^\circ\text{C}$	-4.6		4.6	%
Offset Voltage	V_{OE}	$I_{\text{P}} = 0\text{A}$, $T_A = 25^\circ\text{C}$	-37		37	mV
		$I_{\text{P}} = 0\text{A}$, $T_A = 25 \sim 125^\circ\text{C}$	-60		60	mV
		$I_{\text{P}} = 0\text{A}$, $T_A = -40 \sim 25^\circ\text{C}$	-41		41	mV
Nonlinearity	E_{LIN}	Measured using full-scale and half-scale I_{P}	-3		3	%
Zero ripple	$V_{\text{OQ_PP}}$	$I_{\text{P}} = 0\text{A}$, $T_A = 25^\circ\text{C}$, Output ripple peak		57.5		mV
ACCURACY PERFORMANCE						
Total Output Error ^[2]	E_{TOT}	$I_{\text{P}} = 50\text{A}$, $T_A = 25^\circ\text{C}$	-2		2	%
		$I_{\text{P}} = 50\text{A}$, $T_A = 25^\circ\text{C} \sim 125^\circ\text{C}$	-4		4	%
		$I_{\text{P}} = 50\text{A}$, $T_A = -40^\circ\text{C} \sim 25^\circ\text{C}$	-5		5	%

[1] Typical value is +/-1 sigma value, and 68.27% of products fall within this range;

The maximum/minimum value is +/-3 sigma, and 99.73% of products fall within this range.

[2] Based on the percentage value of peak current I_{P} conditions.

SC780-050B Individual Performance Characteristics

Note: Over full range of $T_A = -40 \sim 125^\circ\text{C}$, $C_{\text{Bypass}} = 4.7 + 0.1 \mu\text{F}$, $C_{\text{Load}} = 1.0 \text{ nF}$, $V_{\text{CC}} = 5\text{V}$, unless otherwise specified.

Characteristic	Symbol	Test Conditions	Min	Typ ^[1]	Max	Unit
NOMINAL PERFORMANCE						
Current-Sensing Range	I_{PR}		-50		50	A
Zero-Current Output Voltage	V_{OQ}	$I_{\text{P}} = 0\text{A}$		$0.5V_{\text{CC}}$		V
Sensitivity	S_{ENS}	$-50\text{A} < I_{\text{P}} < 50\text{A}$		$40 * S_{\text{COEF}}$		mV/A
TOTAL OUTPUT ERROR COMPONENTS: $E_{\text{TOT}} = E_{\text{SENS}} + V_{\text{OE}} / (S_{\text{ENS}} \times I_{\text{P}})$						
Sensitivity Error	E_{SENS}	$I_{\text{P}} = \pm 50\text{A}$, $T_A = 25^\circ\text{C}$	-2.1		2.1	%
		$I_{\text{P}} = \pm 50\text{A}$, $T_A = 25 \sim 125^\circ\text{C}$	-3.5		3.5	%
		$I_{\text{P}} = \pm 50\text{A}$, $T_A = -40 \sim 25^\circ\text{C}$	-2.2		2.2	%
Offset Voltage	V_{OE}	$I_{\text{P}} = 0\text{A}$, $T_A = 25^\circ\text{C}$	-20		20	mV
		$I_{\text{P}} = 0\text{A}$, $T_A = 25 \sim 125^\circ\text{C}$	-30		30	mV
		$I_{\text{P}} = 0\text{A}$, $T_A = -40 \sim 25^\circ\text{C}$	-25		25	mV
Nonlinearity	E_{LIN}	Measured using full-scale and half-scale I_{P}	-0.8		0.8	%
Zero ripple	$V_{\text{OQ_PP}}$	$I_{\text{P}} = 0\text{A}$, $T_A = 25^\circ\text{C}$, Output ripple peak		42.5		mV
ACCURACY PERFORMANCE						
Total Output Error ^[2]	E_{TOT}	$I_{\text{P}} = \pm 50\text{A}$, $T_A = 25^\circ\text{C}$	-2.1		2.1	%
		$I_{\text{P}} = \pm 50\text{A}$, $T_A = 25^\circ\text{C} \sim 125^\circ\text{C}$	-3.7		3.7	%
		$I_{\text{P}} = \pm 50\text{A}$, $T_A = -40^\circ\text{C} \sim 25^\circ\text{C}$	-2.5		2.5	%

[1] Typical value is +/-1 sigma value, and 68.27% of products fall within this range;

The maximum/minimum value is +/-3 sigma, and 99.73% of products fall within this range.

[2] Based on the percentage value of peak current I_{P} conditions.

SC780-100B Individual Performance Characteristics

Note: Over full range of $T_A = -40 \sim 125^\circ\text{C}$, $C_{\text{Bypass}} = 4.7 + 0.1 \mu\text{F}$, $C_{\text{Load}} = 1.0 \text{nF}$, $V_{\text{CC}} = 5\text{V}$, unless otherwise specified.

Characteristic	Symbol	Test Conditions	Min	Typ ^[1]	Max	Unit
NOMINAL PERFORMANCE						
Current-Sensing Range	I_{PR}		-100		100	A
Zero-Current Output Voltage	V_{OQ}	$I_{\text{P}} = 0\text{A}$		$0.5V_{\text{CC}}$		V
Sensitivity	Sens	$-100\text{A} < I_{\text{P}} < 100\text{A}$		$20 * S_{\text{coef}}$		mV/A
TOTAL OUTPUT ERROR COMPONENTS: $E_{\text{TOT}} = E_{\text{SENS}} + V_{\text{OE}} / (\text{Sens} \times I_{\text{P}})$						
Sensitivity Error	E_{SENS}	$I_{\text{P}} = \pm 100\text{A}$, $T_A = 25^\circ\text{C}$	-2.1		2.1	%
		$I_{\text{P}} = \pm 100\text{A}$, $T_A = 25 \sim 125^\circ\text{C}$	-3.5		3.5	%
		$I_{\text{P}} = \pm 100\text{A}$, $T_A = -40 \sim 25^\circ\text{C}$	-2.2		2.2	%
Offset Voltage	V_{OE}	$I_{\text{P}} = 0\text{A}$, $T_A = 25^\circ\text{C}$	-20		20	mV
		$I_{\text{P}} = 0\text{A}$, $T_A = 25 \sim 125^\circ\text{C}$	-30		30	mV
		$I_{\text{P}} = 0\text{A}$, $T_A = -40 \sim 25^\circ\text{C}$	-25		25	mV
Nonlinearity	E_{LIN}	Measured using full-scale and half-scale I_{P}	-0.8		0.8	%
Zero ripple	$V_{\text{OQ_pp}}$	$I_{\text{P}} = 0\text{A}$, $T_A = 25^\circ\text{C}$, Output ripple peak		36.3		mV
ACCURACY PERFORMANCE						
Total Output Error ^[2]	E_{TOT}	$I_{\text{P}} = \pm 100\text{A}$, $T_A = 25^\circ\text{C}$	-2.1		2.1	%
		$I_{\text{P}} = \pm 100\text{A}$, $T_A = 25^\circ\text{C} \sim 125^\circ\text{C}$	-3.7		3.7	%
		$I_{\text{P}} = \pm 100\text{A}$, $T_A = -40^\circ\text{C} \sim 25^\circ\text{C}$	-2.5		2.5	%

[1] Typical value is +/-1 sigma value, and 68.27% of products fall within this range;

The maximum/minimum value is +/-3 sigma, and 99.73% of products fall within this range.

[2] Based on the percentage value of peak current I_{P} conditions.

SC780-100U Individual Performance Characteristics

Note: Over full range of $T_A = -40 \sim 125^\circ\text{C}$, $C_{\text{Bypass}} = 4.7 + 0.1 \mu\text{F}$, $C_{\text{Load}} = 1.0 \text{nF}$, $V_{\text{CC}} = 5\text{V}$, unless otherwise specified.

Characteristic	Symbol	Test Conditions	Min	Typ ^[1]	Max	Unit
NOMINAL PERFORMANCE						
Current-Sensing Range	I_{PR}		0		100	A
Zero-Current Output Voltage	V_{OQ}	$I_{\text{P}} = 0\text{A}$		$0.1V_{\text{CC}}$		V
Sensitivity	Sens	$0 < I_{\text{P}} < 100\text{A}$		$40 * S_{\text{coef}}$		mV/A
TOTAL OUTPUT ERROR COMPONENTS: $E_{\text{TOT}} = E_{\text{SENS}} + V_{\text{OE}} / (\text{Sens} \times I_{\text{P}})$						
Sensitivity Error	E_{SENS}	$I_{\text{P}} = 100\text{A}$, $T_A = 25^\circ\text{C}$	-0.8		0.8	%
		$I_{\text{P}} = 100\text{A}$, $T_A = 25 \sim 125^\circ\text{C}$	-3.3		3.3	%
		$I_{\text{P}} = 100\text{A}$, $T_A = -40 \sim 25^\circ\text{C}$	-4.8		4.8	%
Offset Voltage	V_{OE}	$I_{\text{P}} = 0\text{A}$, $T_A = 25^\circ\text{C}$	-12		12	mV
		$I_{\text{P}} = 0\text{A}$, $T_A = 25 \sim 125^\circ\text{C}$	-24		24	mV
		$I_{\text{P}} = 0\text{A}$, $T_A = -40 \sim 25^\circ\text{C}$	-15		15	mV
Nonlinearity	E_{LIN}	Measured using full-scale and half-scale I_{P}	-1		1	%
Zero ripple	$V_{\text{OQ_pp}}$	$I_{\text{P}} = 0\text{A}$, $T_A = 25^\circ\text{C}$, Output ripple peak		40.6		mV
ACCURACY PERFORMANCE						
Total Output Error ^[2]	E_{TOT}	$I_{\text{P}} = 100\text{A}$, $T_A = 25^\circ\text{C}$	-0.5		0.5	%
		$I_{\text{P}} = 100\text{A}$, $T_A = 25^\circ\text{C} \sim 125^\circ\text{C}$	-3.6		3.6	%
		$I_{\text{P}} = 100\text{A}$, $T_A = -40^\circ\text{C} \sim 25^\circ\text{C}$	-4.7		4.7	%

[1] Typical value is +/-1 sigma value, and 68.27% of products fall within this range;

The maximum/minimum value is +/-3 sigma, and 99.73% of products fall within this range.

[2] Based on the percentage value of peak current I_{P} conditions.

SC780-150B Individual Performance Characteristics

Note: Over full range of $T_A = -40 \sim 125^\circ\text{C}$, $C_{\text{Bypass}} = 4.7 + 0.1 \mu\text{F}$, $C_{\text{Load}} = 1.0 \text{nF}$, $V_{\text{CC}} = 5\text{V}$, unless otherwise specified.

Characteristic	Symbol	Test Conditions	Min	Typ ^[1]	Max	Unit
NOMINAL PERFORMANCE						
Current-Sensing Range	I_{PR}		-150		150	A
Zero-Current Output Voltage	V_{OQ}	$I_{\text{P}} = 0\text{A}$		$0.5V_{\text{CC}}$		V
Sensitivity	Sens	$-150\text{A} < I_{\text{P}} < 150\text{A}$		$13.33^* S_{\text{coef}}$		mV/A
TOTAL OUTPUT ERROR COMPONENTS: $E_{\text{TOT}} = E_{\text{SENS}} + V_{\text{OE}} / (\text{Sens} \times I_{\text{P}})$						
Sensitivity Error	E_{SENS}	$I_{\text{P}} = \pm 150\text{A}$, $T_A = 25^\circ\text{C}$	-0.9		0.9	%
		$I_{\text{P}} = \pm 150\text{A}$, $T_A = 25 \sim 125^\circ\text{C}$	-3		3	%
		$I_{\text{P}} = \pm 150\text{A}$, $T_A = -40 \sim 25^\circ\text{C}$	-1.9		1.9	%
Offset Voltage	V_{OE}	$I_{\text{P}} = 0\text{A}$, $T_A = 25^\circ\text{C}$	-10		10	mV
		$I_{\text{P}} = 0\text{A}$, $T_A = 25 \sim 125^\circ\text{C}$	-16		16	mV
		$I_{\text{P}} = 0\text{A}$, $T_A = -40 \sim 25^\circ\text{C}$	-9		9	mV
Nonlinearity	E_{LIN}	Measured using full-scale and half-scale I_{P}	-0.8		0.8	%
Zero ripple	$V_{\text{OQ_pp}}$	$I_{\text{P}} = 0\text{A}$, $T_A = 25^\circ\text{C}$, Output ripple peak		27.5		mV
ACCURACY PERFORMANCE						
Total Output Error ^[2]	E_{TOT}	$I_{\text{P}} = \pm 150\text{A}$, $T_A = 25^\circ\text{C}$	-0.75		0.75	%
		$I_{\text{P}} = \pm 150\text{A}$, $T_A = 25^\circ\text{C} \sim 125^\circ\text{C}$	-3.4		3.4	%
		$I_{\text{P}} = \pm 150\text{A}$, $T_A = -40^\circ\text{C} \sim 25^\circ\text{C}$	-2.1		2.1	%

[1] Typical value is +/-1 sigma value, and 68.27% of products fall within this range;

The maximum/minimum value is +/-3 sigma, and 99.73% of products fall within this range.

[2] Based on the percentage value of peak current I_{P} conditions.

SC780-150U Individual Performance Characteristics

Note: Over full range of $T_A = -40 \sim 125^\circ\text{C}$, $C_{\text{Bypass}} = 4.7 + 0.1 \mu\text{F}$, $C_{\text{Load}} = 1.0 \text{nF}$, $V_{\text{CC}} = 5\text{V}$, unless otherwise specified.

Characteristic	Symbol	Test Conditions	Min	Typ ^[1]	Max	Unit
NOMINAL PERFORMANCE						
Current-Sensing Range	I_{PR}		0		150	A
Zero-Current Output Voltage	V_{OQ}	$I_{\text{P}} = 0\text{A}$		$0.1V_{\text{CC}}$		V
Sensitivity	Sens	$0 < I_{\text{P}} < 150\text{A}$		$26.66^* S_{\text{coef}}$		mV/A
TOTAL OUTPUT ERROR COMPONENTS: $E_{\text{TOT}} = E_{\text{SENS}} + V_{\text{OE}} / (\text{Sens} \times I_{\text{P}})$						
Sensitivity Error	E_{SENS}	$I_{\text{P}} = 150\text{A}$, $T_A = 25^\circ\text{C}$	-0.8		0.8	%
		$I_{\text{P}} = 150\text{A}$, $T_A = 25 \sim 125^\circ\text{C}$	-3.3		3.3	%
		$I_{\text{P}} = 150\text{A}$, $T_A = -40 \sim 25^\circ\text{C}$	-4.8		4.8	%
Offset Voltage	V_{OE}	$I_{\text{P}} = 0\text{A}$, $T_A = 25^\circ\text{C}$	-12		12	mV
		$I_{\text{P}} = 0\text{A}$, $T_A = 25 \sim 125^\circ\text{C}$	-24		24	mV
		$I_{\text{P}} = 0\text{A}$, $T_A = -40 \sim 25^\circ\text{C}$	-15		15	mV
Nonlinearity	E_{LIN}	Measured using full-scale and half-scale I_{P}	-1		1	%
Zero ripple	$V_{\text{OQ_pp}}$	$I_{\text{P}} = 0\text{A}$, $T_A = 25^\circ\text{C}$, Output ripple peak		30		mV
ACCURACY PERFORMANCE						
Total Output Error ^[2]	E_{TOT}	$I_{\text{P}} = 150\text{A}$, $T_A = 25^\circ\text{C}$	-0.5		0.5	%
		$I_{\text{P}} = 150\text{A}$, $T_A = 25^\circ\text{C} \sim 125^\circ\text{C}$	-3.6		3.6	%
		$I_{\text{P}} = 150\text{A}$, $T_A = -40^\circ\text{C} \sim 25^\circ\text{C}$	-4.7		4.7	%

[1] Typical value is +/-1 sigma value, and 68.27% of products fall within this range;

The maximum/minimum value is +/-3 sigma, and 99.73% of products fall within this range.

[2] Based on the percentage value of peak current I_{P} conditions.

SC780-200B Individual Performance Characteristics

Note: Over full range of $T_A = -40 \sim 85^\circ\text{C}$, $C_{\text{Bypass}} = 4.7 + 0.1\mu\text{F}$, $C_{\text{Load}} = 1.0\text{nF}$, $V_{\text{CC}} = 5\text{V}$, unless otherwise specified.

Characteristic	Symbol	Test Conditions	Min	Typ ^[1]	Max	Unit
NOMINAL PERFORMANCE						
Current-Sensing Range	I_{PR}		-200		200	A
Zero-Current Output Voltage	V_{OQ}	$I_{\text{P}} = 0\text{A}$		$0.5V_{\text{CC}}$		V
Sensitivity	S_{ENS}	$-200\text{A} < I_{\text{P}} < 200\text{A}$		$10 * S_{\text{COEF}}$		mV/A
TOTAL OUTPUT ERROR COMPONENTS: $E_{\text{TOT}} = E_{\text{SENS}} + V_{\text{OE}} / (S_{\text{ENS}} \times I_{\text{P}})$						
Sensitivity Error	E_{SENS}	$I_{\text{P}} = \pm 200\text{A}$, $T_A = 25^\circ\text{C}$	-0.9		0.9	%
		$I_{\text{P}} = \pm 200\text{A}$, $T_A = 25 \sim 85^\circ\text{C}$	3		3	%
		$I_{\text{P}} = \pm 200\text{A}$, $T_A = -40 \sim 25^\circ\text{C}$	-1.9		1.9	%
Offset Voltage	V_{OE}	$I_{\text{P}} = 0\text{A}$, $T_A = 25^\circ\text{C}$	-10		10	mV
		$I_{\text{P}} = 0\text{A}$, $T_A = 25 \sim 85^\circ\text{C}$	-16		16	mV
		$I_{\text{P}} = 0\text{A}$, $T_A = -40 \sim 25^\circ\text{C}$	-9		9	mV
Nonlinearity	E_{LIN}	Measured using full-scale and half-scale I_{P}	-0.8		0.8	%
Zero ripple	$V_{\text{OQ_PP}}$	$I_{\text{P}} = 0\text{A}$, $T_A = 25^\circ\text{C}$, Output ripple peak		25		mV
ACCURACY PERFORMANCE						
Total Output Error ^[2]	E_{TOT}	$I_{\text{P}} = \pm 200\text{A}$, $T_A = 25^\circ\text{C}$	-0.75		0.75	%
		$I_{\text{P}} = \pm 200\text{A}$, $T_A = 25^\circ\text{C} \sim 85^\circ\text{C}$	-3.4		3.4	%
		$I_{\text{P}} = \pm 200\text{A}$, $T_A = -40^\circ\text{C} \sim 25^\circ\text{C}$	-2.1		2.1	%

[1] Typical value is +/-1 sigma value, and 68.27% of products fall within this range;

The maximum/minimum value is +/-3 sigma, and 99.73% of products fall within this range.

[2] Based on the percentage value of peak current I_{P} conditions.

SC780-200U Individual Performance Characteristics

Note: Over full range of $T_A = -40 \sim 85^\circ\text{C}$, $C_{\text{Bypass}} = 4.7 + 0.1\mu\text{F}$, $C_{\text{Load}} = 1.0\text{nF}$, $V_{\text{CC}} = 5\text{V}$, unless otherwise specified.

Characteristic	Symbol	Test Conditions	Min	Typ ^[1]	Max	Unit
NOMINAL PERFORMANCE						
Current-Sensing Range	I_{PR}		0		200	A
Zero-Current Output Voltage	V_{OQ}	$I_{\text{P}} = 0\text{A}$		$0.1V_{\text{CC}}$		V
Sensitivity	S_{ENS}	$0\text{A} < I_{\text{P}} < 200\text{A}$		$20 * S_{\text{COEF}}$		mV/A
TOTAL OUTPUT ERROR COMPONENTS: $E_{\text{TOT}} = E_{\text{SENS}} + V_{\text{OE}} / (S_{\text{ENS}} \times I_{\text{P}})$						
Sensitivity Error	E_{SENS}	$I_{\text{P}} = 200\text{A}$, $T_A = 25^\circ\text{C}$	-0.8		0.8	%
		$I_{\text{P}} = 200\text{A}$, $T_A = 25 \sim 85^\circ\text{C}$	-3.3		3.3	%
		$I_{\text{P}} = 200\text{A}$, $T_A = -40 \sim 25^\circ\text{C}$	-4.8		4.8	%
Offset Voltage	V_{OE}	$I_{\text{P}} = 0\text{A}$, $T_A = 25^\circ\text{C}$	-12		12	mV
		$I_{\text{P}} = 0\text{A}$, $T_A = 25 \sim 85^\circ\text{C}$	-24		24	mV
		$I_{\text{P}} = 0\text{A}$, $T_A = -40 \sim 25^\circ\text{C}$	-15		15	mV
Nonlinearity	E_{LIN}	Measured using full-scale and half-scale I_{P}	-1		1	%
Zero ripple	$V_{\text{OQ_PP}}$	$I_{\text{P}} = 0\text{A}$, $T_A = 25^\circ\text{C}$, Output ripple peak		26.9		mV
ACCURACY PERFORMANCE						
Total Output Error ^[2]	E_{TOT}	$I_{\text{P}} = 200\text{A}$, $T_A = 25^\circ\text{C}$	-0.5		0.5	%
		$I_{\text{P}} = 200\text{A}$, $T_A = 25^\circ\text{C} \sim 85^\circ\text{C}$	-3.6		3.6	%
		$I_{\text{P}} = 200\text{A}$, $T_A = -40^\circ\text{C} \sim 25^\circ\text{C}$	-4.7		4.7	%

[1] Typical value is +/-1 sigma value, and 68.27% of products fall within this range;

The maximum/minimum value is +/-3 sigma, and 99.73% of products fall within this range.

[2] Based on the percentage value of peak current I_{P} conditions.

Accuracy characteristic curve

SC780-050U-PFF

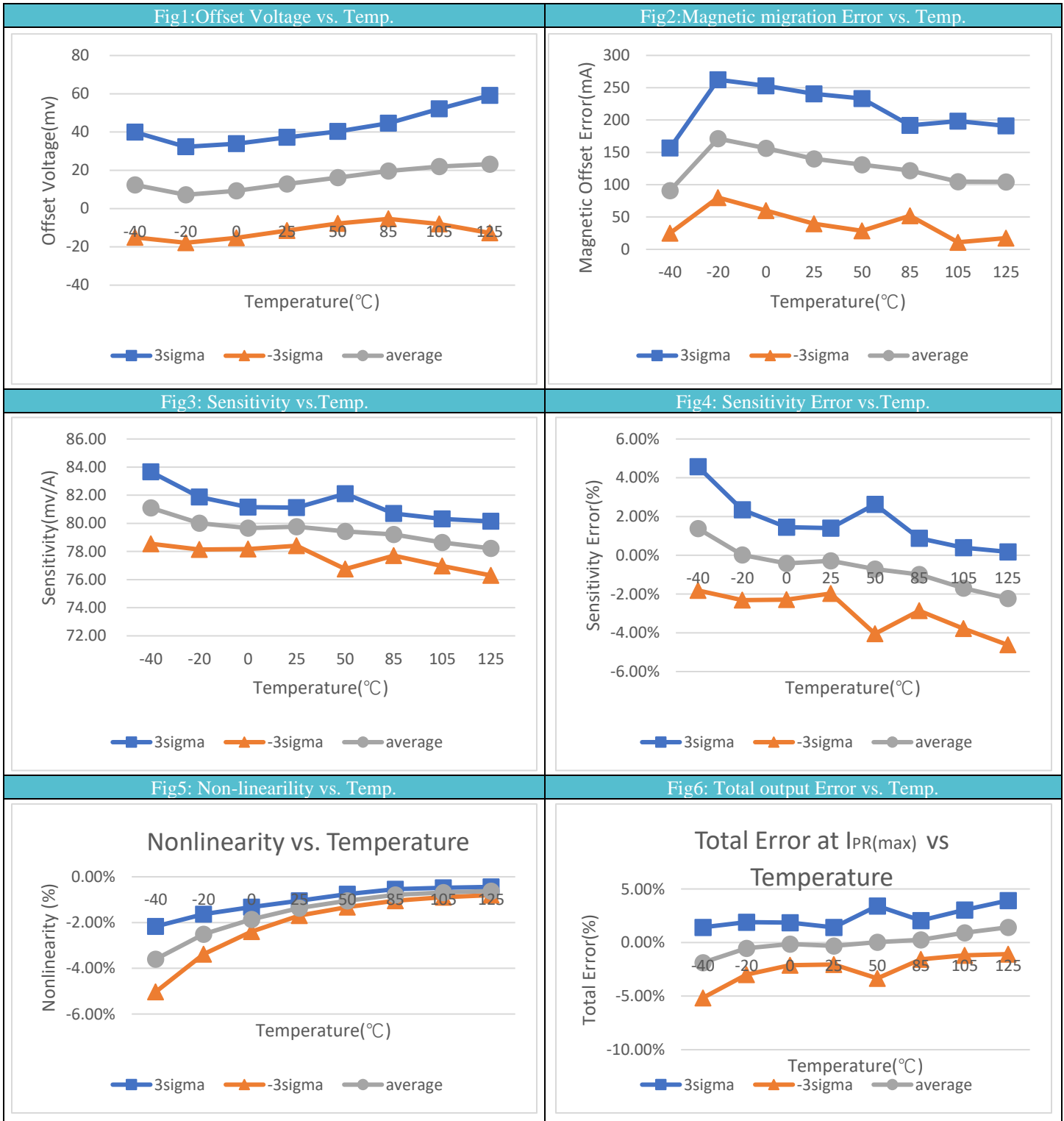

Accuracy characteristic curve

SC780-050B-PFF

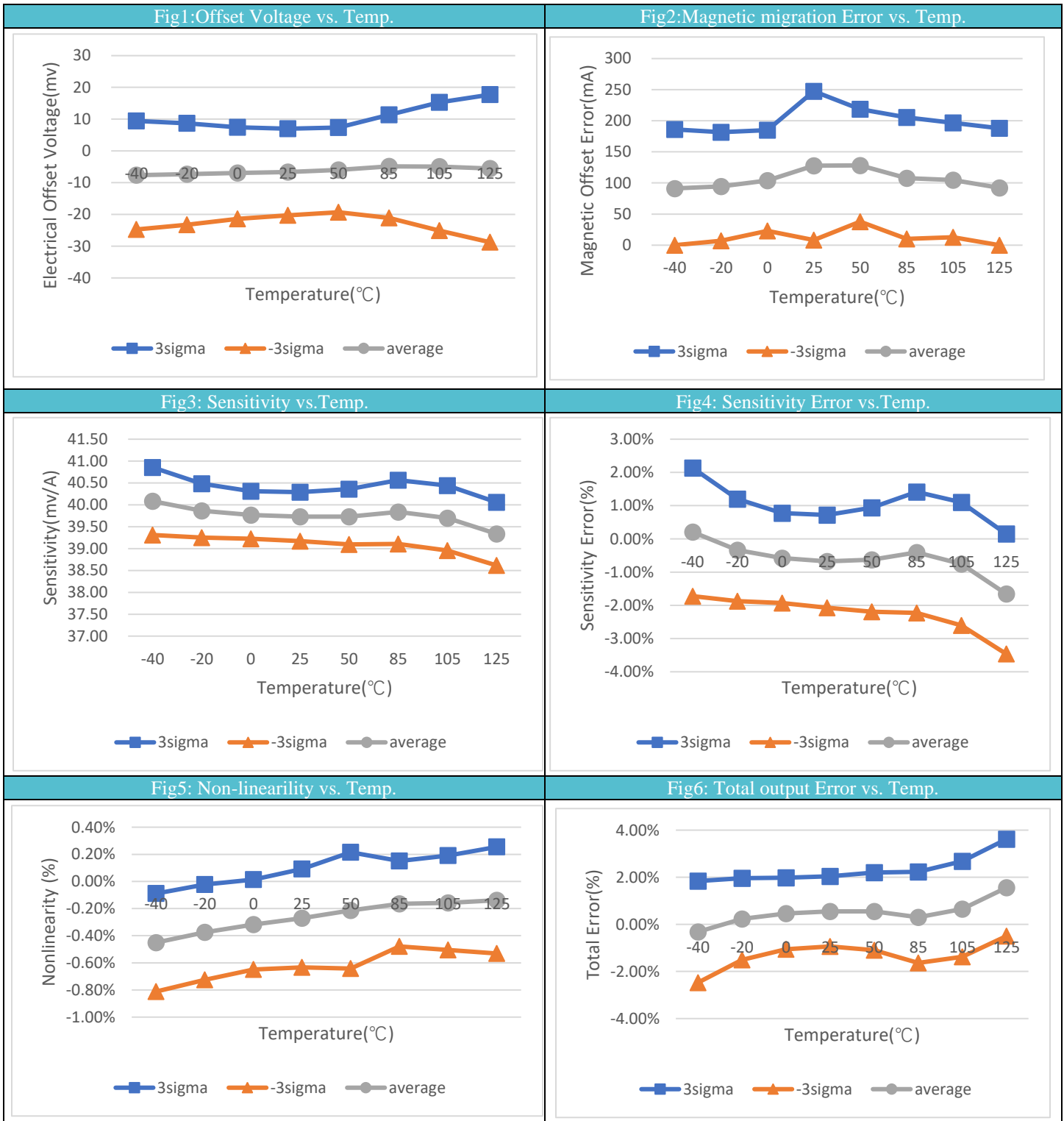

Accuracy characteristic curve

Based on SC780-150B-PFF



AC & Dynamic Characteristic Curve

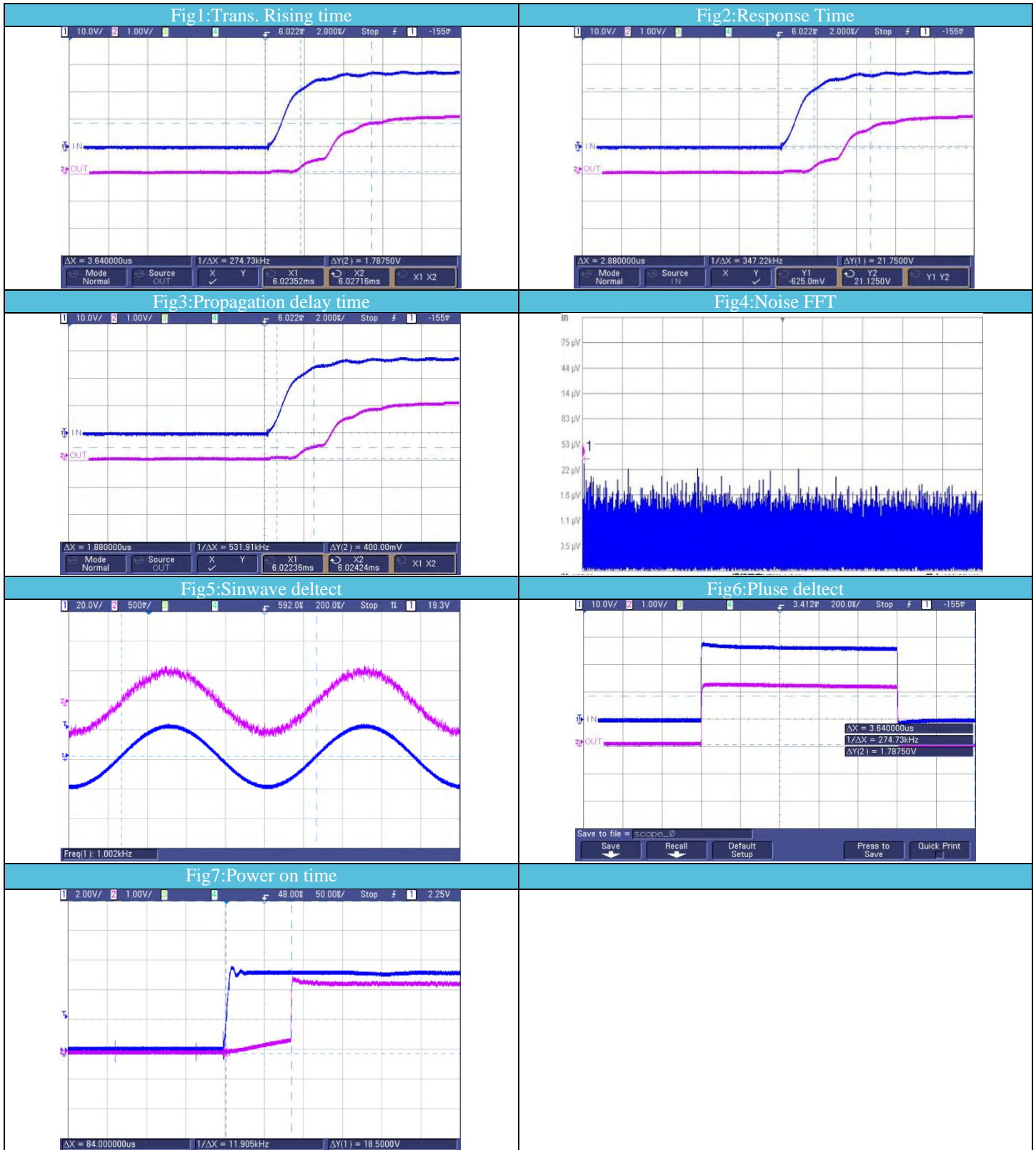

Characteristic parameter definition description

◆ Proportional Coefficient Of Sensitivity(suitable for products with suffix B or U)

$$S_{coef} = Sens_coef = SENS_{VCC} / SENS_{VCCN}$$

It is the ratio of the sensitivity $SENS_{VCC}$ under the supply voltage V_{cc} to the sensitivity $SENS_{VCCN}$ under the rated supply voltage V_{CCN} . Through this value, we can get the sensitivity under any supply voltage.

In ideal situation:

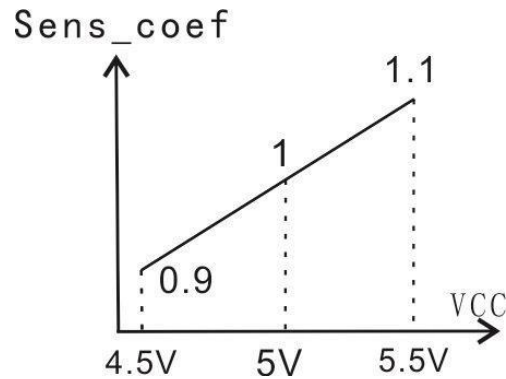

◆ Proportional Relationship

- Using SC780-xxxB-PFF, sensitivity and zero voltage are changing with VCC proportion, zero for the $V_{CC} / 2$, sensitivity to $SENS_{VCC} * Sens_coef$.
- Using SC780-xxxU-PFF, sensitivity and zero voltage are changing with VCC proportion, zero for the $V_{CC} / 2$, sensitivity to $SENS_{VCC} * Sens_coef$.

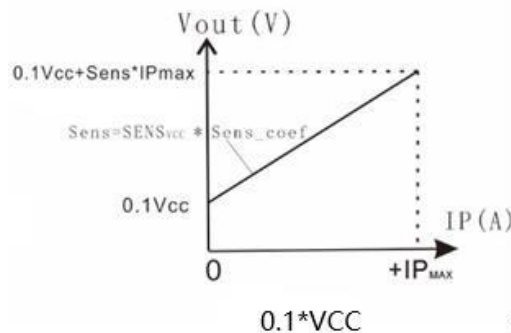
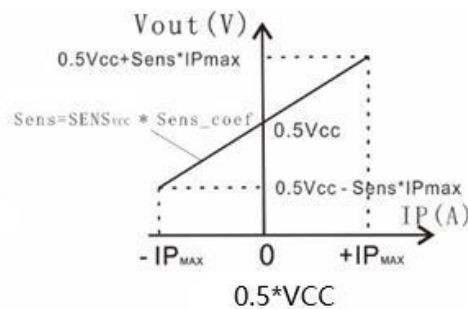

◆ Delay time t_{pd} and Response time $t_{response}$

Both delay time and response time are used to characterize the time difference between primary side and secondary side;

Propagation delay time(t_{pd})

The delay time is the time difference when the secondary output reaches 20% of the steady-state output value and the primary output reaches 20% of the steady-state current.

The response time ($t_{RESPONSE}$)

The response time is the time difference when the secondary output reaches 90% of the steady-state output value and when the primary output reaches 90% of the steady-state current.

Rise Time (t_r)

The rising time is used to represent the time difference of the secondary side itself, that is, the time difference between the time when the output of the secondary side reaches 90% of the steady-state output value and 10% of the steady-state output value.

Power-On Time (t_{PO})

Power on time is used to represent the time difference between the secondary side and the power supply VCC, that is, the time difference between the secondary side output reaching the steady-state output value and the VCC reaching the steady-state output value.

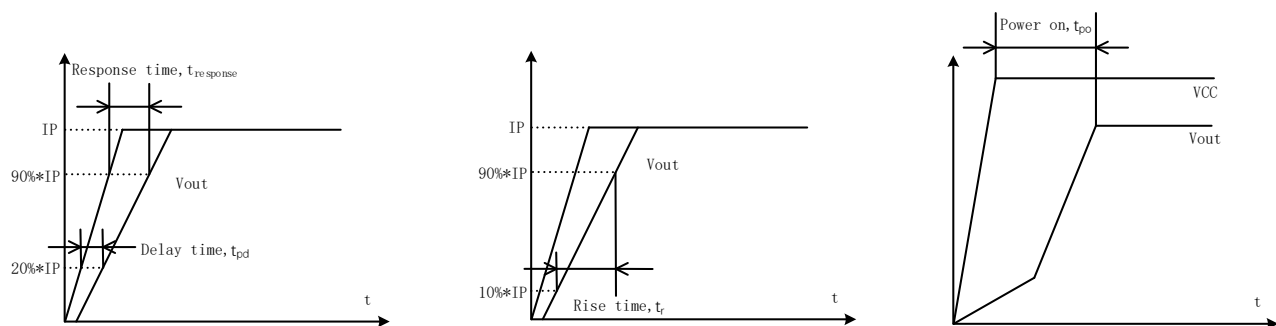

◆ Thermal resistance $R_{\theta JA}$

Based on a demo board, the thermal resistance is calculated by measuring the chip top temperature and power value. According to the thermal resistance, the junction temperature can be calculated as a reference. The actual surface temperature measurement value is shown in the relationship between the package temperature and the measured current.

$$T_J = T_A + (R_{\theta JA} * POWER) = T_A + (R_{\theta JA} * IP^2 * R_{PRIMARY});$$

Where T_J is junction temperature and T_A is ambient temperature.

Demo Board Layout

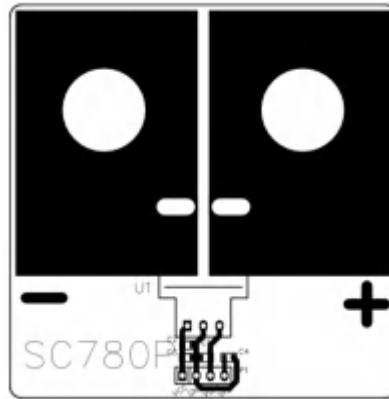

Mark Description

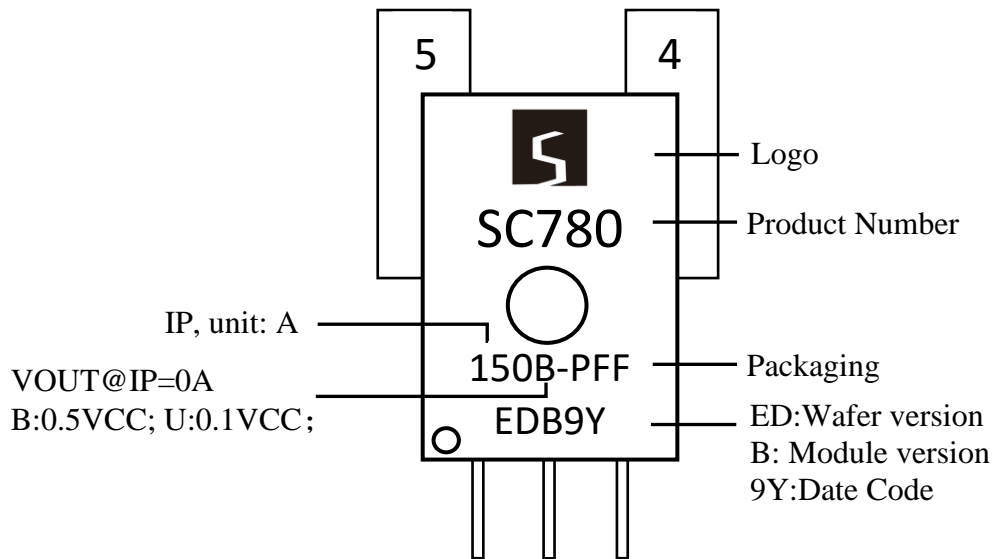

Package Information

Note:all dimensions are in millimeters.

SC780-PFF

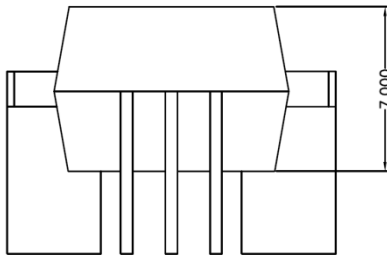
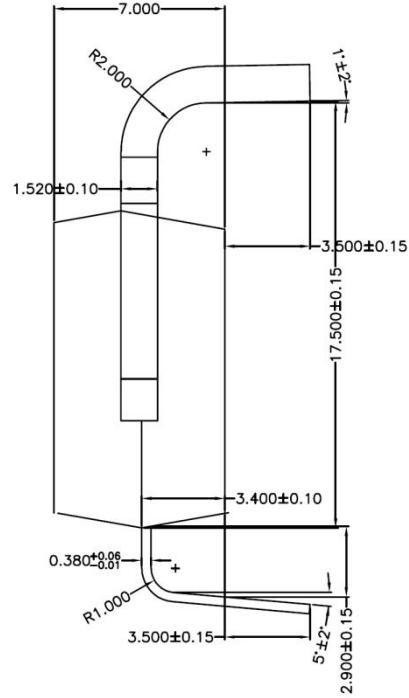
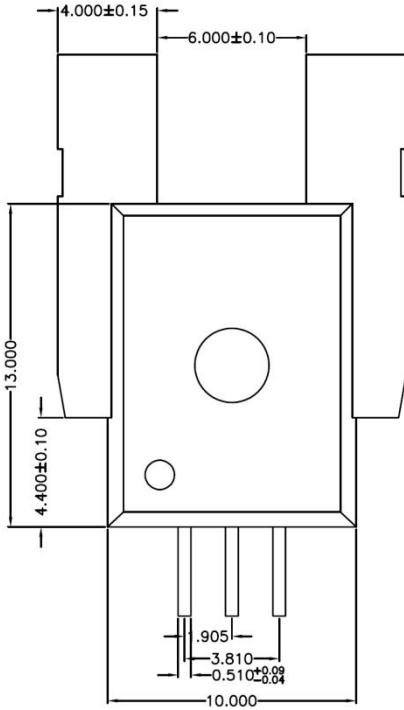

PCB layout Reference View

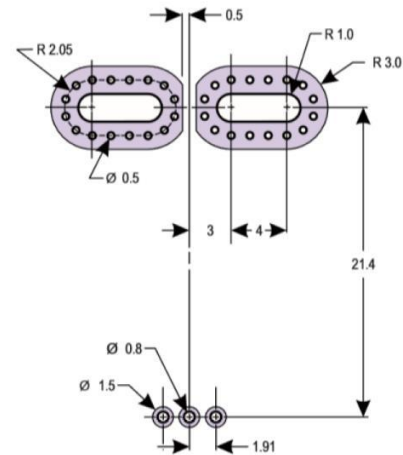

NOTES:

- 1.GENERAL TOLERANCE: LINEAR ± 0.05 , ANGULAR $\pm 1^\circ$, RADIUS ± 0.05 .
- 2.PKG SURFACE $R_a=0.70\sim 0.90\mu m$ EXCEPT SLEEK AREAS.
- 3.EJECTION & INDEX PIN MARK DEPTH 0.20 ± 0.10 .
- 4.GENERAL CORNER RADIUS R0.15.
- 5.MAX RESIN GATE PROTRUSION 0.25MAX.
- 6.ALL DIMENSIONS IN MILLIMETERS.

Package Information

Note:all dimensions are in millimeters.

SC780-PSF

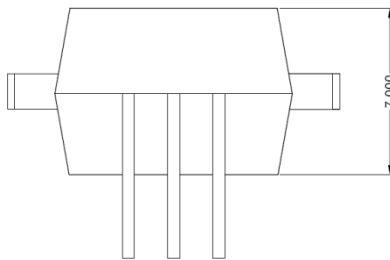
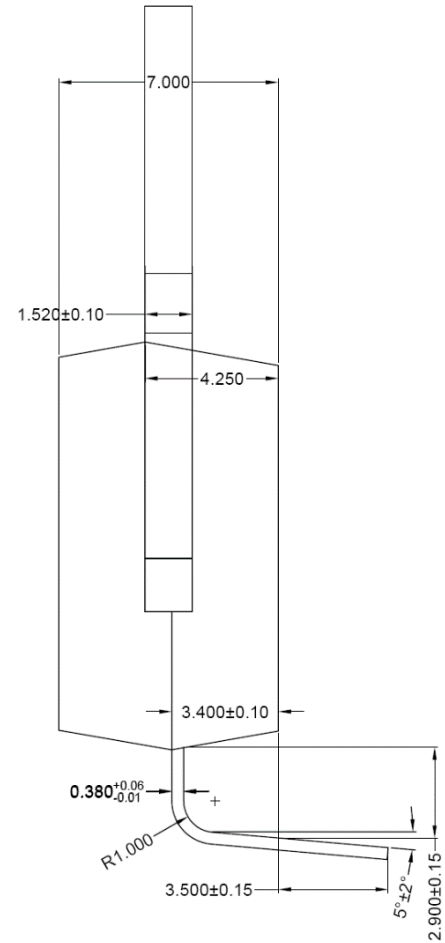
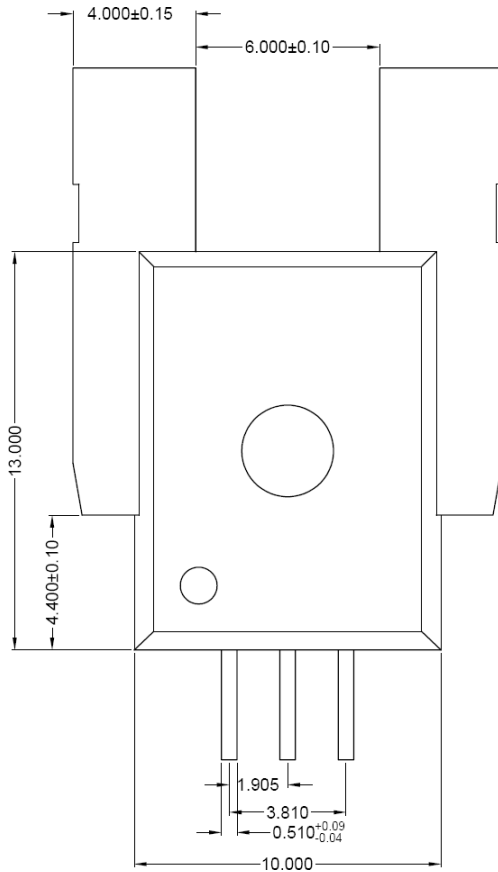

NOTES:

- 1.GENERAL TOLERANCE: LINEAR ±0.05, ANGULAR ±1°, RADIUS ±0.05.
- 2.PKG SURFACE Ra=0.70-0.90um EXCEPT SLEEK AREAS.
- 3.EJECTION & INDEX PIN MARK DEPTH0.20±0.10.
- 4.GENERAL CORNER RADIUS R0.15.
- 5.MAX RESIN GATE PROTRUSION 0.25MAX.
- 6.ALL DIMENSIONS IN MILLIMETERS.

PCB layout Reference View

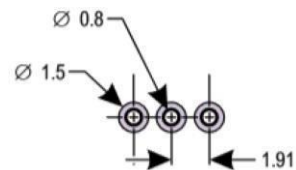

Package Information

Note:all dimensions are in millimeters.

SC780-PSS

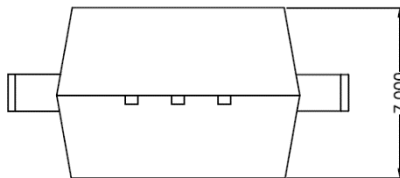
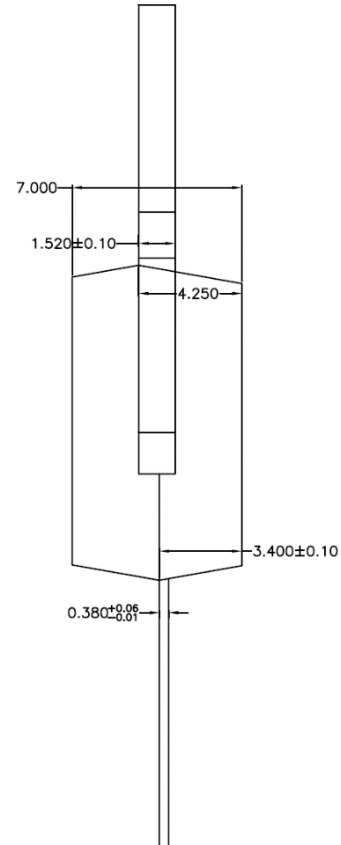
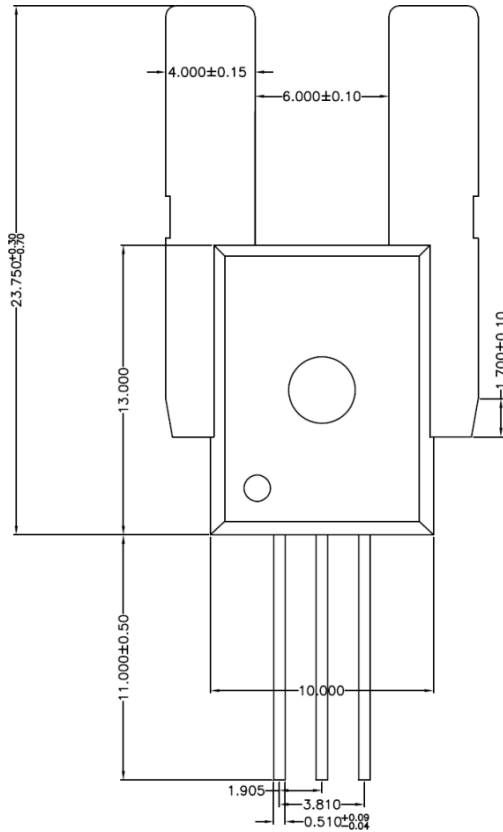

PCB layout Reference View

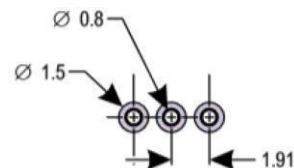

NOTES:

- 1.GENERAL TOLERANCE: LINEAR ± 0.05 , ANGULAR $\pm 1^\circ$, RADIUS ± 0.05 .
- 2.PKG SURFACE $R_a=0.70\sim 0.90\mu m$ EXCEPT SLEEK AREAS.
- 3.EJECTION & INDEX PIN MARK DEPTH 0.20 ± 0.10 .
- 4.GENERAL CORNER RADIUS $R0.15$.
- 5.MAX RESIN GATE PROTRUSION 0.25MAX.
- 6.ALL DIMENSIONS IN MILLIMETERS.

Contact us

Shenzhen Vicorv Technology Co., Ltd. is a high-tech company which is dedicated to high-end chip solutions. Its core team is from well-known foreign companies in the industry, with nearly 15 years of experience in electronic IC development. The company is committed to providing customers with IC solutions for automotive electronics, special applications, military industry, industrial control etc.

Fax: 0755-32997328

Telephone: 15814787138

URL: <http://www.gchsensor.com>

Post code: 518040

Operation Center: Wenyong Times Center, Fuhai Street,
Baoan District, Shenzhen City, Guangdong province, China.

