

POWER MANAGEMENT

Description

The SC803 is a fully integrated, single cell, constant-current constant-voltage Lithium-Ion battery charger management system. The SC803 has built in intelligence and extreme functionality. When the battery voltage is below 2.8V the charger operates in a pre-charge mode with a charging current of up to 125mA based on the ITERM pin resistor. This pre-charge mode is set to limit power dissipation due to an undercharged battery. When the battery voltage exceeds 2.8V, the charger enters a fast charge mode. In this mode, the SC803 delivers up to 1.5A to the battery based on the IPRGM pin resistor.

The part also features current termination, ending the charge cycle when the battery is charged and the charge current drops below the current programmed by the ITERM pin resistor. In addition, the charge current can be monitored by the voltage on the IPRGM pin allowing a microcontroller or ADC to access the current information to determine when to externally terminate the charge cycle. Once the charge cycle is complete and terminates, the device enters the charge monitor mode where the output voltage of the battery is monitored. If this voltage drops below the recharge threshold the device will enter the fast charge mode again, to bring the battery to its fully charged state. Both the shutdown and monitor modes drain no more than 1uA from the battery guaranteed.

The output voltage to the battery is controlled to within 1% of the programmed voltage for either 4.1V or 4.2V. The SC803 can also function as a general purpose current source or as a current source for charging nickel-cadmium (NiCd) and nickel-metal-hydride (NiMH) batteries using external termination.

Typical Application Circuit

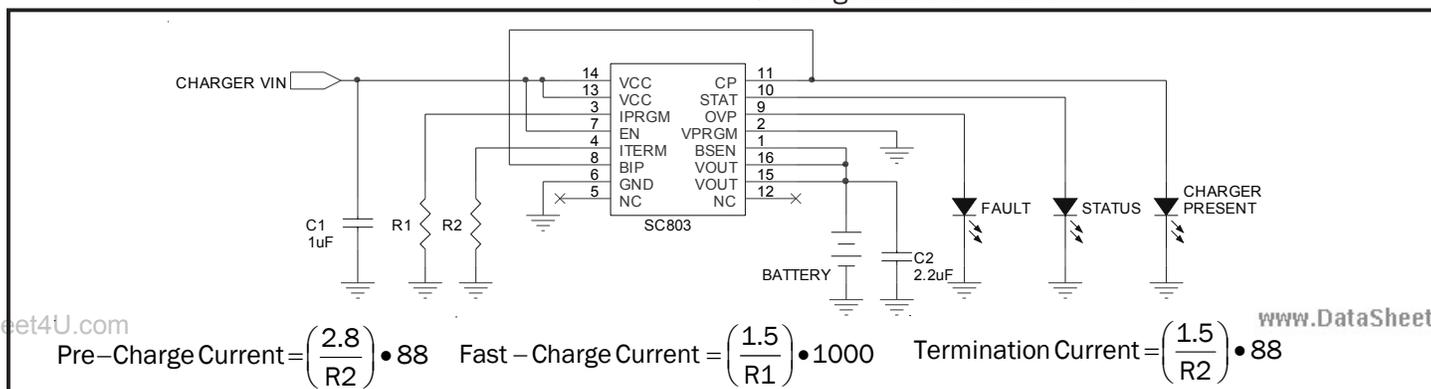

Features

- ◆ Fully integrated charger with FET pass transistor, reverse-blocking diode, sense resistor and thermal protection
- ◆ Complete voltage ranges of 4.1V, 4.2V & adjustable
- ◆ Programmable precharge, fastcharge & termination current
- ◆ Battery voltage controlled to 1% accuracy
- ◆ Soft-start for step load and adaptor plug-in
- ◆ Up to 1.5A continuous charge current
- ◆ Charge current monitor output from microcontroller or ADC Interface
- ◆ Input voltages range from 4.2V to 7V
- ◆ 0.1uA Battery drain current in shutdown and monitor modes
- ◆ Operates without a battery in regulated LDO mode
- ◆ Small 4mm x 4mm 16 lead MLP package
- ◆ Low thermal impedance of 50°C/watt
- ◆ Few external components
- ◆ Over current protection in all charging modes
- ◆ Over voltage protection with fault pin output
- ◆ All outputs able to drive LED's and interface to host processor
- ◆ Remote Kelvin sensing at the battery terminal
- ◆ Small input & output filter capacitors
- ◆ Status output communicates charging and end of charge cycle

Applications

- ◆ Cellular phones
- ◆ PDA's
- ◆ Handheld meters
- ◆ Charging stations
- ◆ Handheld computers
- ◆ Digital cameras
- ◆ Programmable current source

POWER MANAGEMENT

Absolute Maximum Ratings

Exceeding the specifications below may result in permanent damage to the device, or device malfunction. Operation outside of the parameters specified in the Electrical Characteristics section is not implied.

Parameter	Symbol	Maximum	Units	
VCC, EN to GND		-0.3 to 7.0	V	
VOUT, VPRGM, IPRGM, CP, OVP, STAT, ITERM, BIP to GND		-0.3 to +6.0	V	
Power Dissipation MLP (Derate 20mW/ °C above 85 °C)	P_D	2.5	W	
VOUT short to GND		Continuous		
Thermal Resistance, Junction to Ambient	θ_{JA}	48	°C/W *	
Operating Junction Temperature	T_J	150	°C	
IR Reflow Temperature (Soldering) 10 seconds	TR option	T_{IRRT}	240	°C
	TRT option (lead-free leadframe)	T_{IRRT}	260	°C
Storage Temperature	T_{STG}	-65 to 150	°C	
ESD Rating (Human Body Model)	ESD	2	kV	

* Tied to PCB with 1 Square Inch, 2 Ounce Copper

Electrical Characteristics

Unless otherwise noted: VCC = 4.75V - 5.25V

Parameter	Symbol	Conditions	25°C			T_A (-40°C to +85°C)		Units
			Min	Typ	Max	Min	Max	
Input Voltage	VCC					4.2	7	V
Operating Voltage	V_{OP}					4.2	6.5	V
Operating Current	I_{CC}	Charging Mode OVP, STATUS, CP = 0µA					2	mA
		LDO Mode OVP, STATUS, CP = 0µA					25	
Battery Leakage Current	I_{VOUT}	VCC = 0V		0.1			1	µA
Regulated Voltage	V_{BAT}	V_{PRGM} = Logic High V_{PRGM} = Logic Low		4.20 4.10		4.16 4.06	4.24 4.14	V
Adjust Mode Feedback Voltage		V_{PRGM} = External Divider V_{CC} = 4.2V - 6.5V		3.0		2.97	3.03	V
Battery Pre-Charge Current	P_{CI}	I_{TERM} Resistor = 3.01kΩ $V_{BATTERY} > 2.5V$		82		72	92	mA
Battery Termination Current	I_{TERM}			45		38	52	
Battery Fast-Charge Current	F_{CI}	I_{PRGM} = 3.01kΩ I_{PRGM} = 1.87kΩ $V_{BATTERY}$ = 3.8V Dropout Voltage = 550mV		500 800		450 750	550 850	mA

POWER MANAGEMENT

Electrical Characteristics Cont.

Unless otherwise noted: VCC = 4.75V - 5.25V

Parameter	Symbol	Conditions	25°C			T _A (-40°C to +85°C)		Units
			Min	Typ	Max	Min	Max	
Battery Fast-Charge Current Limit		$2.8V < V_{BATTERY} < V_{BAT}$ Dropout voltage = 1V					1.5**	A
I _{PROG} Regulated Voltage				1.5		1.4	1.6	V
V _{IN} UVLO Rising Threshold				4.2			4.3	V
Adjust Mode Threshold Voltage				90				mV
V _{BAT} Precharge Threshold				2.8		2.7	2.9	V
V _{BAT} Recharge Threshold		$V_{BAT} - V_{BATTERY}$		200		170	230	mV
V _{IN} OVP Rising Threshold				6.8		6.525	7.0	V
V _{IN} OVP Falling Threshold				6.5		6.2	6.8	V
V _{IN} OVP Hysteresis				300		200	400	mV
Over Temperature Shutdown		Hysteresis = 10°C		165				°C
Status Output Source Current		Pre-Charge or Fast-Charge VSTAT = 2.8V		10				mA
		End of Charge, VSTAT = 0.25V		1				mA
		No Adaptor or LDO mode, High Impedance		1				µA
OVP Output Source Current		VCC > OVP		10				mA
CP Output Source Current		VCC > UVLO		10				mA
BSENSE Input Leakage Current				0.1			1	µA
STAT, OVP, CP Outputs	V _{OH}	Load = 10mA				2.4		V
		Load = 1mA				2.6		
	V _{OL}	Load = -500µA					0.25	V
STAT Output	V _{OH}	Load = 0mA		2.8			3.0	V
EN, BIP, VPRGM Inputs	V _{IH}					1.8		V
	V _{IL}						0.4	V
EN Input Sink Current		EN Voltage = 1.8V		4			10	µA

** Thermally Limited

POWER MANAGEMENT

Pin Configuration

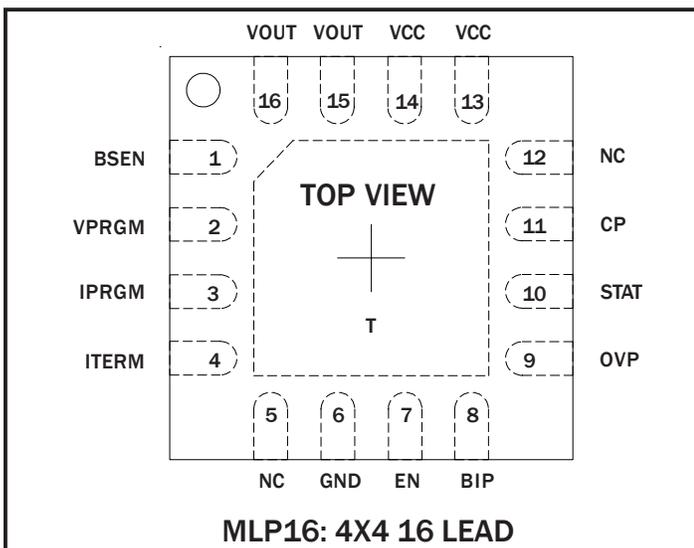

Ordering Information

DEVICE ⁽¹⁾	PACKAGE
SC803IMLTR	MLP16
SC803IMLTRT ⁽²⁾	MLP16
SC803EVB ⁽³⁾	Evaluation Board

Notes:

(1) Only available in tape and reel packaging. A reel contains 3,000 devices.

(2) TRT extension designates the lead-free leadframe package option.

(3) Specify the desired IC part number when ordering.

Pin Descriptions

Pin #	Pin Name	Pin Function
1	BSEN	Battery voltage sense pin. Connect to battery terminal to Kelvin sense battery voltage. Do not leave this pin floating.
2	VPRGM	Selectable voltage program pin. Logic low = 4.1V. Logic high = 4.2V. Resistor = adjustable.
3	IPRGM	Charger current program pin in fast charge mode. Requires a resistor to ground to program fast-charge current.
4	ITERM	Selection for current termination and pre-charge current. Requires a resistor to ground to program pre-charge and termination current.
5	NC	No Connect
6	GND	Ground
7	EN	Device enable/disable pin. Logic high enables device. Logic low disables device.
8	BIP	Input derived from external circuitry or microcontroller that signals Battery In Place. Logic high indicates Battery In Place and in charging mode. Logic low puts device into LDO mode. Do not leave this pin floating.
9	OVP	Overvoltage fault flag if charger input voltage is higher than 6.5V. This pin can source 10mA.
10	STAT	Charger Status Pin: Pre-charge (High), Fastcharge (High) and end of charge (Low). When in LDO mode this pin is high impedance. This pin can source 10mA.
11	CP	Charger present indicator, logic high when there is power to the VCC pins regardless of the Enable pin state. This pin can source 10mA.
12	NC	No Connect
13	VCC	Supply pin, connect to adaptor power.
14	VCC	Supply pin, connect to adaptor power.
15	VOUT	Charger output, connect to battery.
16	VOUT	Charger output, connect to battery.
T	Thermal Pad	Thermal-conduction pad on bottom of the package. Solder directly to the ground plane with multiple thermal vias to all other ground planes.



POWER MANAGEMENT

Block Diagram

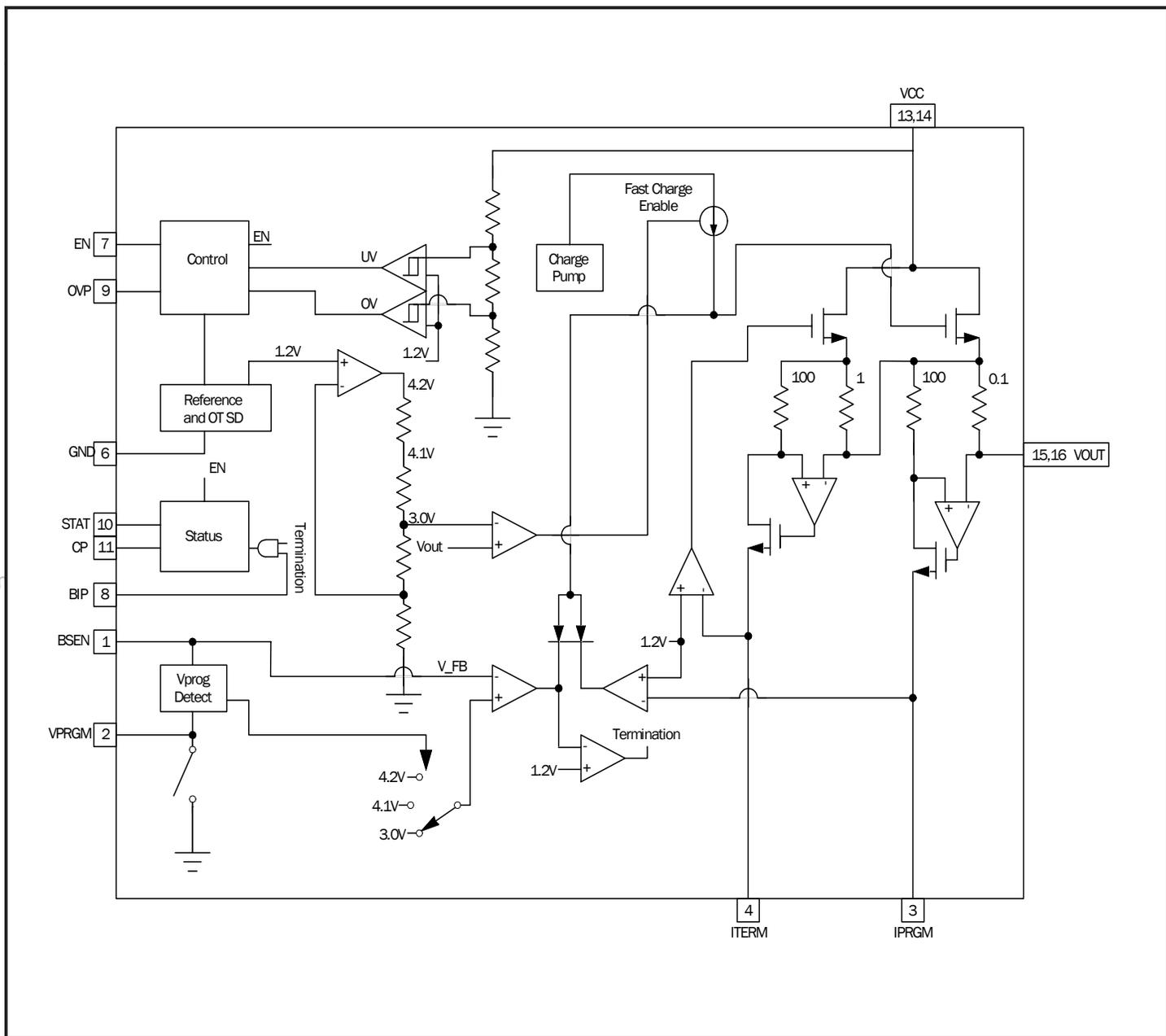

POWER MANAGEMENT

Applications Information

Pre-Charge Mode

Pre-charge mode is automatically enabled whenever the battery voltage is below 2.8V. It is primarily used to limit the power dissipation of the battery and the SC803 device whenever the battery is undercharged. As the battery begins to charge in this mode, the voltage of the battery will rise and when the 2.8V limit is reached, the SC803 will switch to the fast charge mode. The pre-charge current value is selected by the termination resistor on the ITERM pin. The maximum range of the pre-charge current is from 10mA to 125mA. Whenever the charger is in pre-charge or fast-charge the status LED will light indicating that the battery is being charged. The equation to select the pre-charge current is given by:

$$PCI = \left(\frac{2.8}{R_{TERM}} \right) \cdot 88$$

Fast-Charge Mode

The fast-charge mode exists while the battery voltage is above 2.8V and the battery is not fully charged. The fast-charge current can be set to a maximum of 1.5A and is selected by the program resistor on the IPRGM pin. In fact, the voltage on this pin will represent the current through the battery enabling a microprocessor or analog-to-digital converter (ADC), to monitor battery current by sensing the voltage on the IPRGM pin. The equation to set the fast-charge current is given by:

$$FCI = \left(\frac{1.5}{R_{PRGM}} \right) \cdot 1000$$

Note that for a given program resistor the current through the battery can be determined by replacing 1.5 with the actual voltage on the IPRGM pin in the above equation.

Termination Current

Once the battery reaches the program voltage of 4.1V, 4.2V or externally set voltage, the device will transition from a constant current source to a constant voltage source, as the current through the battery begins to decrease while the voltage remains constant. During this time when the current falls below the programmed termination current set by the termination resistor on the ITERM pin, the SC803 will turn off and the end of charge will be indicated by the status LED turning off. The equation to set the termination current is given by:

$$ITERM = \left(\frac{1.5}{R_{TERM}} \right) \cdot 88$$

Monitor Mode

In the monitor mode the voltage of the battery will be monitored against the programmed voltage. This will occur after a battery has been fully charged and the device has shut off. If the voltage of the battery falls below the recharge threshold (specified at 200mV) the charger will activate and charge the battery to its programmed voltage. This means that it will enter the full charging sequence from fast-charge to terminating the charging cycle when the programmed termination current is reached. The maximum current drain of the battery during monitor mode will be no more than 1uA over temperature.

LDO Mode

One of the nice features of the SC803 is its ability to work with or without a battery. If the battery is not in place the device can enter the LDO mode. In this mode the SC803 will act like a low dropout regulator. The output voltage is set to 4.1V, 4.2V or externally set by a resistor divider. See the section titled "Configuring the Output Voltage to the Battery" for setting an output voltage other than 4.1V or 4.2V. The input pin BIP (Battery In Place) is used to switch the SC803 from charger mode to LDO mode. If this pin is logic high the device will be in charger mode, if it is logic low it will be in the LDO mode. During LDO mode the device will regulate the output voltage with a current limit set by the resistor tied to the IPRGM pin. The BIP pin can be tied to the CP pin to place the device in charge mode whenever the adaptor is in place. The maximum voltage on the BIP input pin is 6V, so do not tie it to the VCC input since this voltage can exceed 6V in some conditions. The BIP pin should never be left floating, but instead, should be tied through pull-up/pull-down resistors when connected to a high impedance control pin, otherwise it can be connected directly to the CP pin or GND. The equation for setting the current limit in the LDO mode will be:

$$ILDO = \left(\frac{1.5}{R_{PRGM}} \right) \cdot 1000$$

LED Flags

There are three LED drivers on the SC803: OVP (Over Voltage), STAT (Status) and CP (Charger Present). Each output can drive an LED directly without a current limit resistor. In addition, each output can be monitored by a microprocessor for change in their status. The following table defines each LED output.

POWER MANAGEMENT

Applications Information (Cont.)

Using the SC803 With a Charge Controller IC

The SC803 can also be used with numerous charge controller ICs on the market. In many instances the charge controller will control the charging and termination of the SC803. The best method of interfacing the SC803 with such a device is to place the SC803 in LDO mode, and monitor the current to the battery by an ADC that samples the voltage on the IPRGM pin. Slow and fast charge can be controlled by placing two resistors in series from IPRGM to GND and adding a transistor switch across one of the resistors. This way the current can be monitored for proper termination by the charge controller. In LDO mode the STAT LED will not light. When charging the battery in LDO mode the charge profile will be the same as in charge mode except there will be no precharge or termination current function. Meanwhile, the maximum current the battery will see is set by the battery equivalent circuit or the fast-charge current limit. The battery will still charge in this mode, albeit a slightly different approach than placing the charger in the charge mode.

Evaluation Board

The evaluation board is shown on Page 10. The evaluation board was designed to test the complete operation of the SC803. Note the minimum parts requirement is shown within the dotted rectangle on the schematic. The adaptor voltage of 5V is applied to TP1 and TP2 which supplies power to the SC803. The output charger voltage or LDO output voltage is taken off of TP4 and TP5. Jumper JP5 will set the device in LDO mode when inserted or charge mode when left open. Jumper JP6 will enable the device when inserted or disable the device when left open. Note as long as power is applied to VCC the CP LED will light, regardless of the EN pin level. Jumper JP4 is used to measure the bias current of the SC803 and should always be in place except when measuring bias current. JP1 and JP3 set the charge limit voltage to 4.2V or 4.1V respectively. Only one of these jumpers JP1 or JP3 should be in place at any given time. If you expect VCC to exceed 6V (testing breakdown of the SC803) and you want to set the output voltage to 4.2V you should remove any jumper on JP1 and manually tie pin 2 of JP1 to the CP pin, because the absolute maximum voltage on the VPRGM input pin is 6V. Jumper JP7 when inserted will short the BSEN line to Vout for charging Lithium-Ion batteries. Jumper JP2 should be inserted when an adjustable voltage is required, with the addition of R1, R2 & C2. For more information about selection of an ad-

justable voltage see the section titled, Configuring the Output Voltage to the Battery. Note, only one of these jumpers JP2 or JP7 should be inserted at any given time. Jumper JP8 should be left open and is used only for testing SC801M operation. Connector J1 is used for connecting the evaluation board to a demonstration platform to exemplify the SC803 operation. Other components on the eval board consist of Semtech's SD12 and SD05 ESD clamp diodes which should be part of any system requiring ESD protection. LED's for status information and TP3 which will allow the current through the battery to be monitored. The input capacitor C1 is chosen to be 10uF to decouple any inductance from a laboratory supply when evaluation is taking place.

Complete Charge Cycle

The complete charge cycle of the SC803 is shown on page 15. The pre-charge current will be under control until the precharge threshold of 2.8V is reached. At this time the device enters the fast-charge mode and the output voltage continues to increase as the constant current is applied to the battery. Eventually constant voltage is reached and the current begins to decrease until the termination current threshold is reached at which time the SC803 will turn off. Many Lithium-Ion batteries have a built in under-voltage detect circuit. This makes the battery pack open circuited when the battery voltage falls below 3V typically. With these batteries the SC803 will unlikely enter pre-charge operation because the battery voltage will always be above 2.8V.



POWER MANAGEMENT

Applications Information (Cont.)

Layout Guidelines

Try to keep the traces from the adaptor input to the VCC pins as wide as possible, to eliminate any voltage drop across the device input traces. You want to make sure the input-to-output voltage differential of the device does not approach the dropout voltage. A curve of the dropout voltage vs. output current is shown on page 15. Any voltage dropped over the input traces from the adaptor will reduce the dropout voltage margin.

Make the high current output trace from the VOUT pins as wide as possible. The BSEN line should be used properly to compensate for any voltage drops from the output trace to the battery. Make a Kelvin connection with the BSEN trace to where VOUT connects the battery terminals. This is done by taking the BSEN trace and tying it to the VOUT trace as close to the battery terminals as possible. This way, any voltage drop across the trace resistance to the battery will be compensated for because BSEN will regulate the device output voltage (VOUT) at the point it connects to the VOUT trace. If you tie the BSEN line to the VOUT pin at the device you will eliminate the benefit of its purpose and the trace resistance drop will not be compensated. Therefore, it is best to have the BSEN trace follow in parallel the VOUT trace and tie them together at the contact point of the battery terminal for the best result.

The bottom of the SC803 package has a heat slug and this slug should be tied to a ground plane of the PCB through one large via or a series of smaller vias. If there is no ground plane, an area should be dedicated on the bottom of the PCB to act as a heat sink. The evaluation board has 1 square inch of copper and allows an output current of greater than 1A. The more copper tied to this slug the greater the output current available before thermal limitations dominate. The two pins that are labeled NC are not connected to the die. Therefore, tying these pins to the ground plane offers no aid in heat removal and has no electrical benefit.



POWER MANAGEMENT

Evaluation Board Schematic

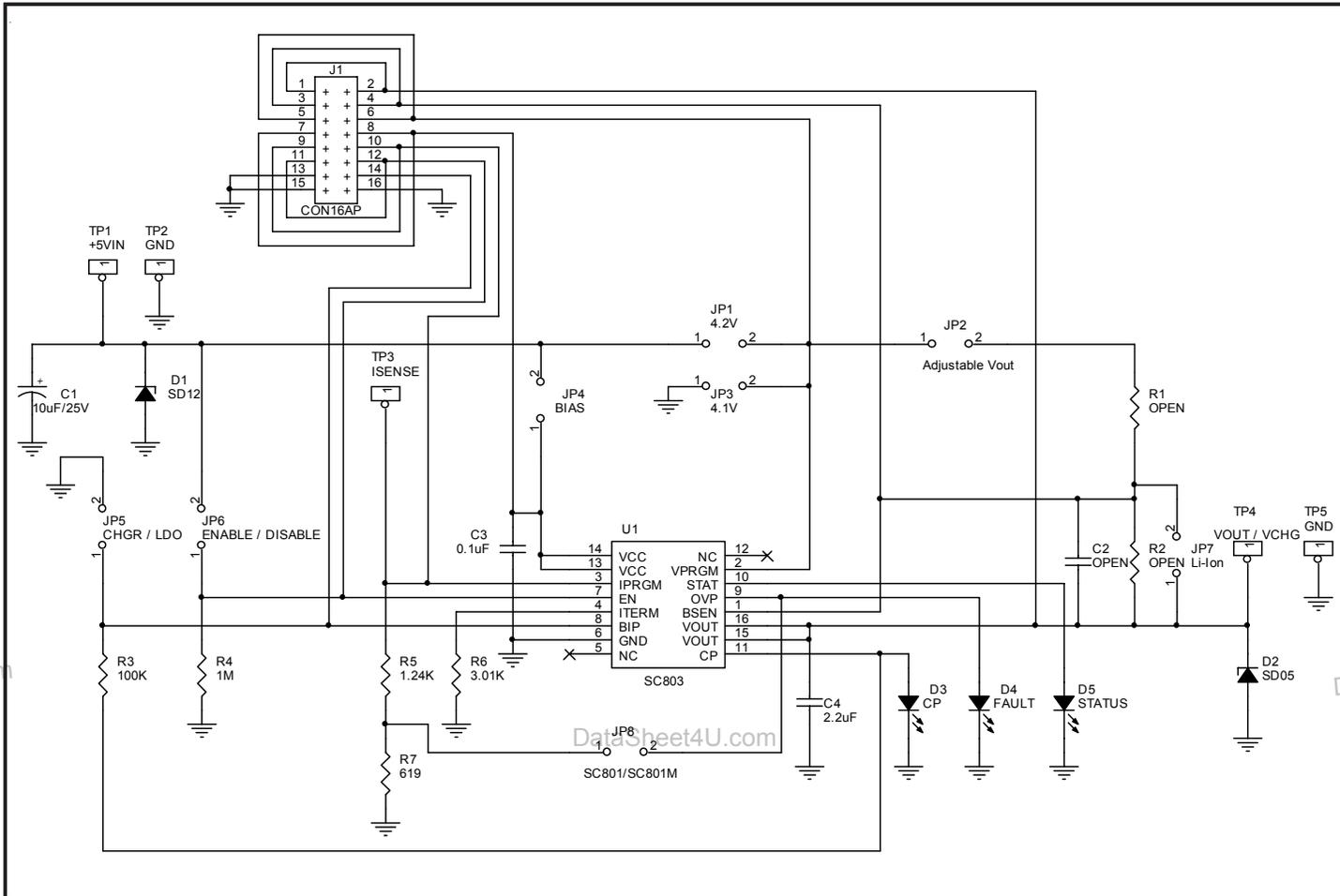

Evaluation Board Gerber Plots

Top Gerber

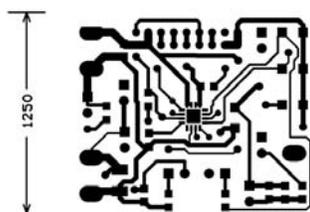

Bottom Gerber

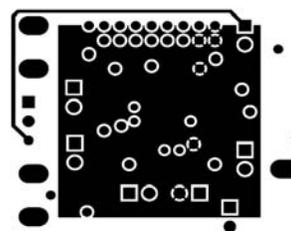

Inner Gerber

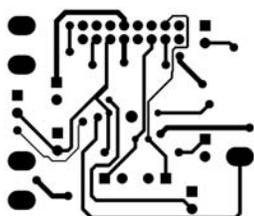

Silk Screen Gerber

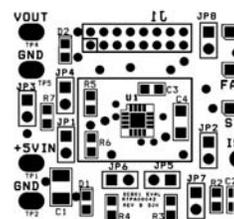

POWER MANAGEMENT

LDO Mode Timing Diagram

LDO Mode

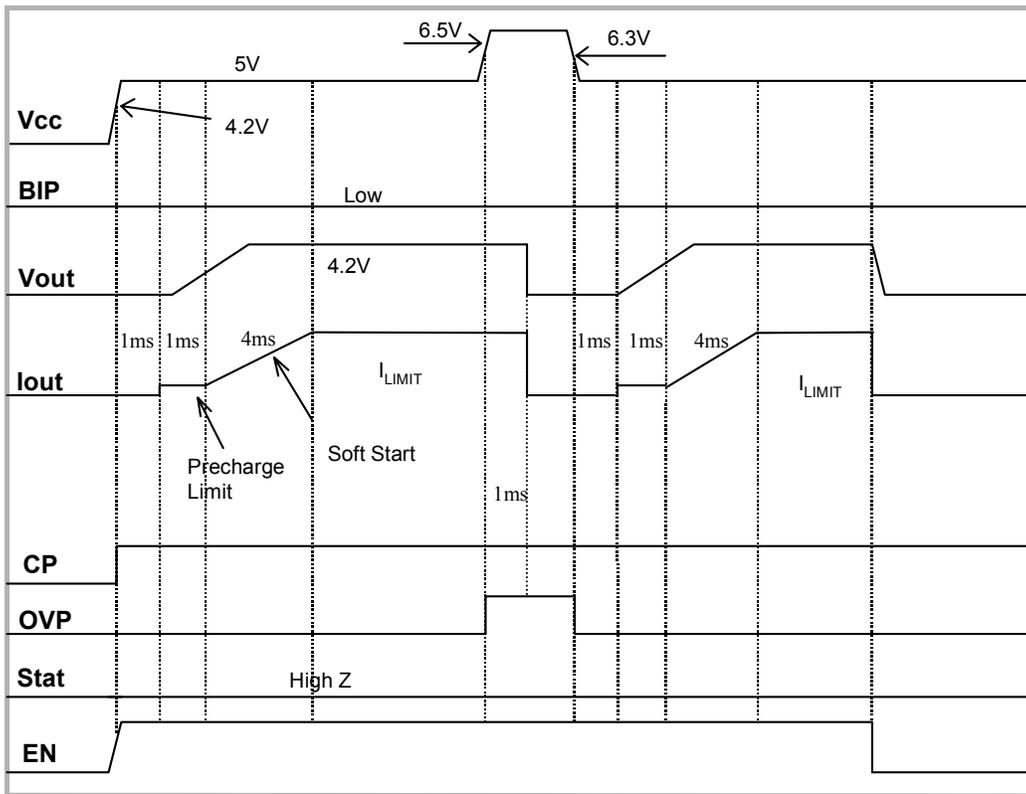

et4U.com

DataShee



POWER MANAGEMENT

Charge Mode Timing Diagram

Charge Mode

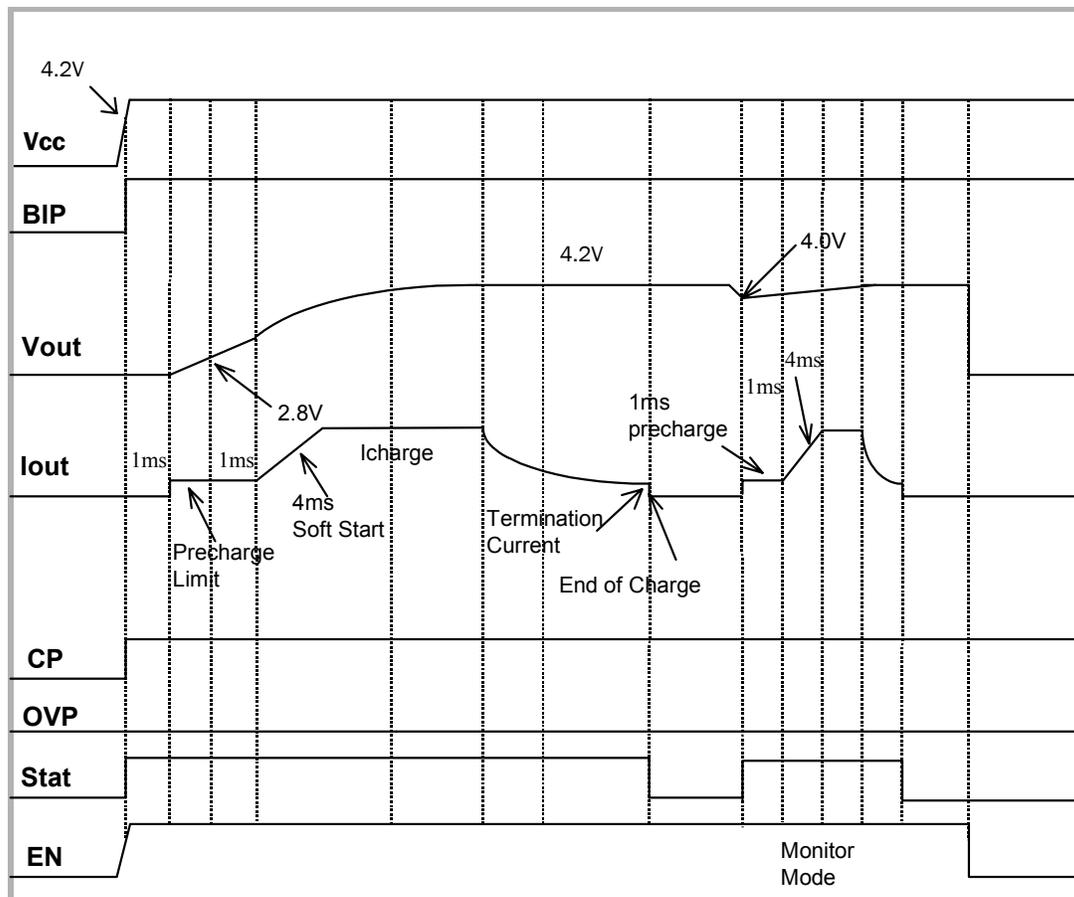

et4U.com

DataShee

POWER MANAGEMENT

Typical Characteristics

LDO Mode Bias Current vs Input Voltage

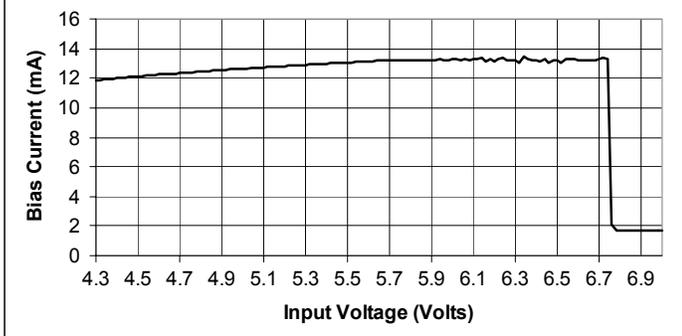

Charge Mode Bias Current vs Input Voltage

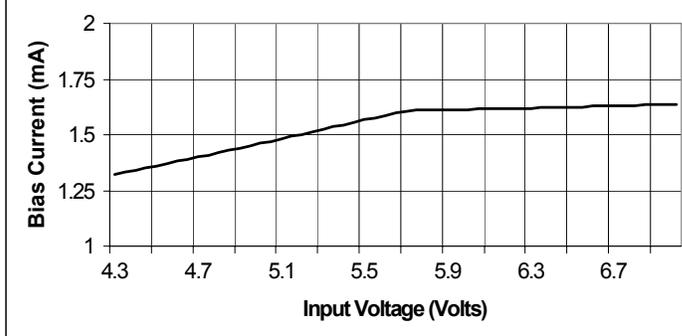

Fast Charge Current vs IPRGM Resistance

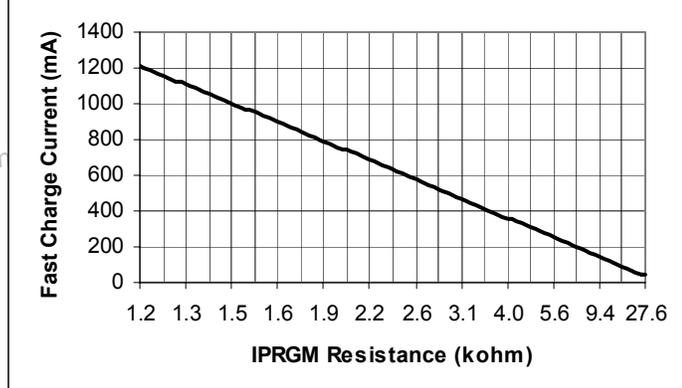

Vout Leakage Current vs Temperature

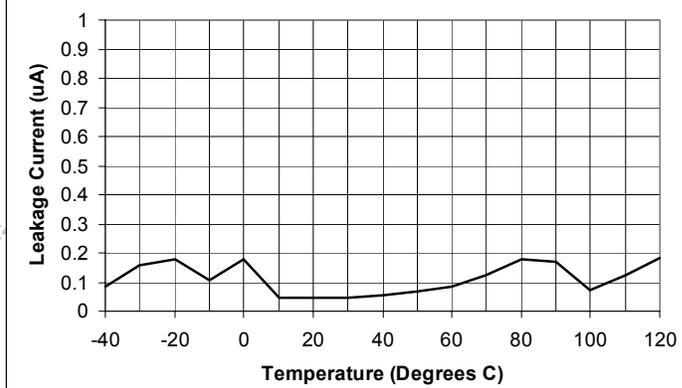

Output Voltage vs Temperature

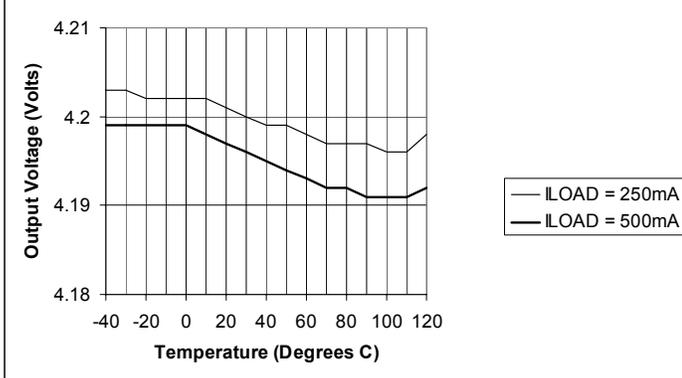

Output Voltage vs Temperature

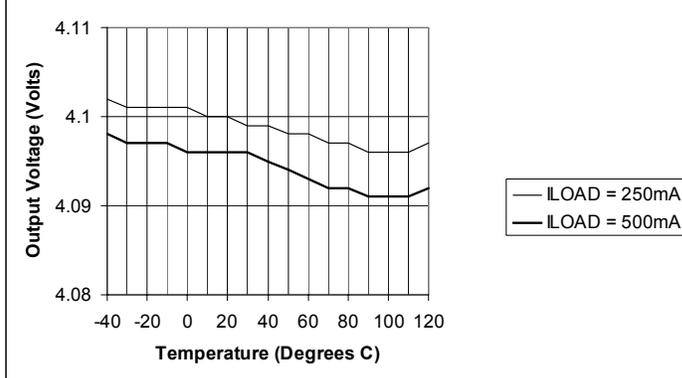



POWER MANAGEMENT

Typical Characteristics

Dropout Voltage vs Output Current

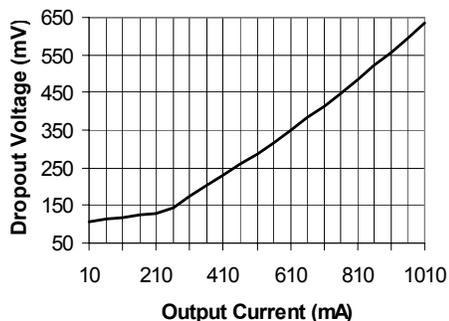

IPRGM Voltage vs Output Current

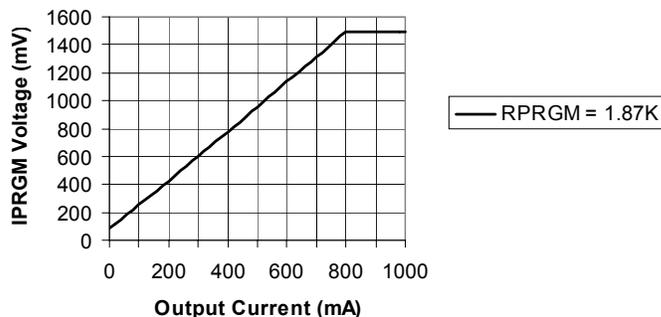

Battery Charge Profile

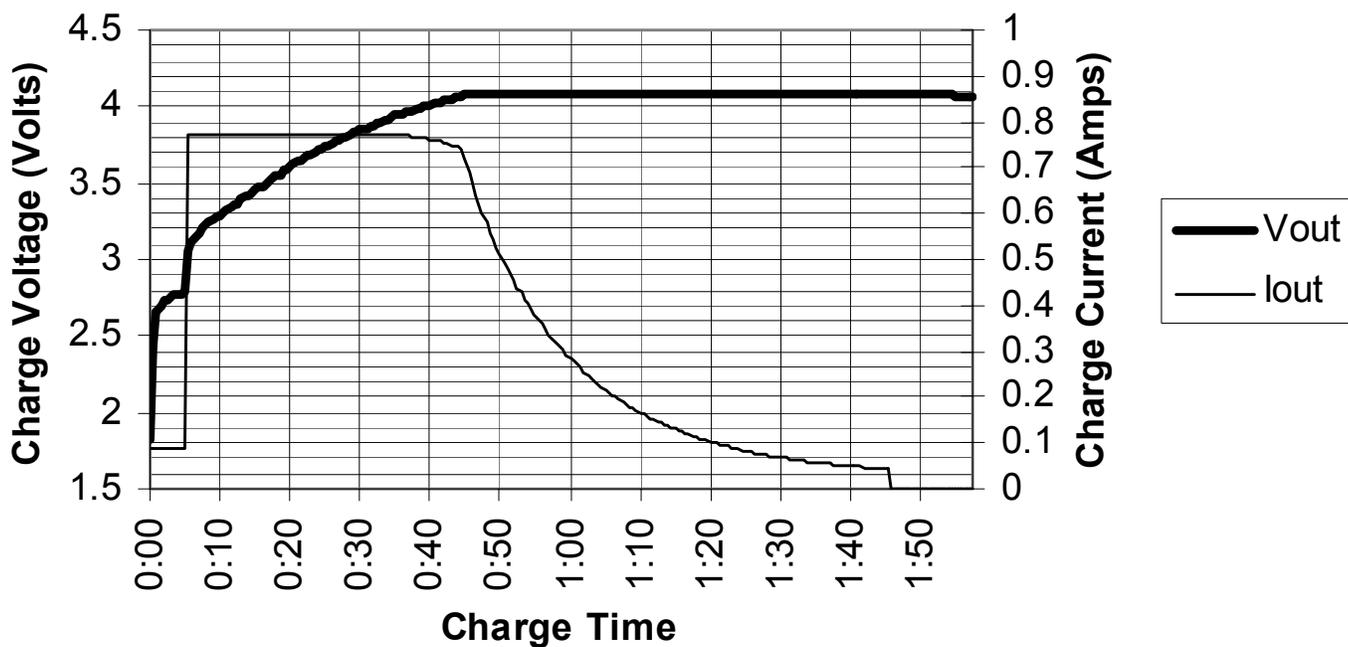



POWER MANAGEMENT

Outline Drawing - MLP (16 pin)

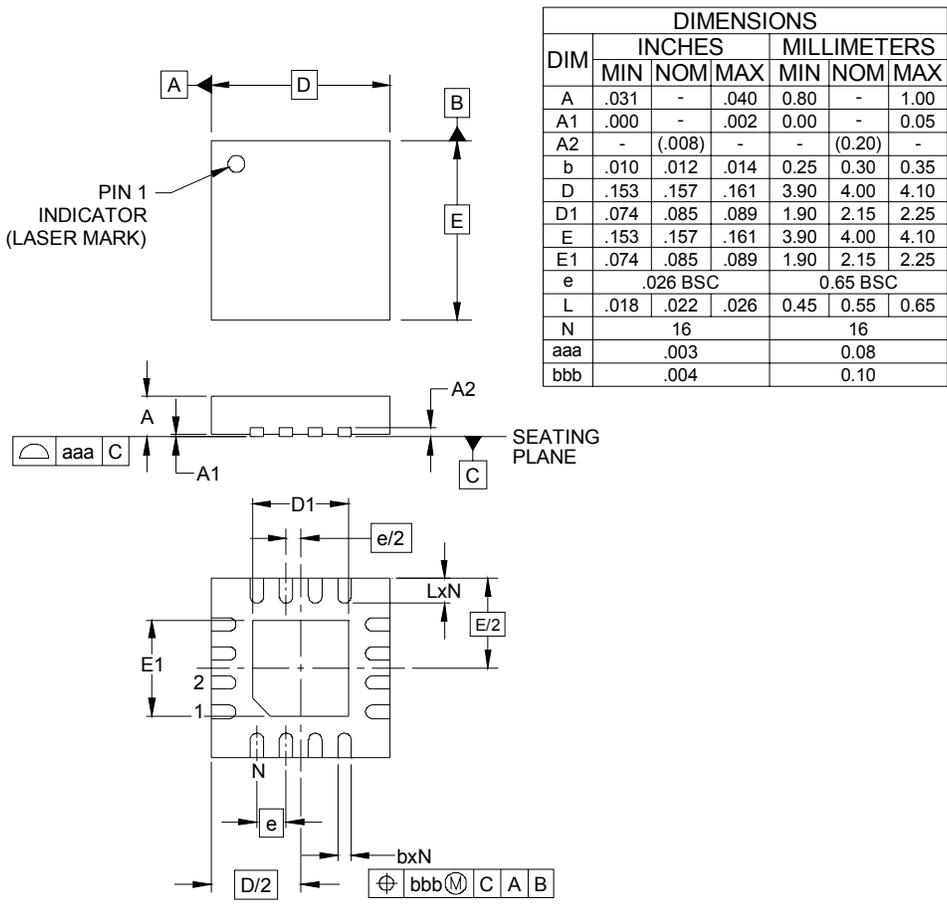

- NOTES:
1. CONTROLLING DIMENSIONS ARE IN MILLIMETERS (ANGLES IN DEGREES).
 2. COPLANARITY APPLIES TO THE EXPOSED PAD AS WELL AS THE TERMINALS.

Marking Information

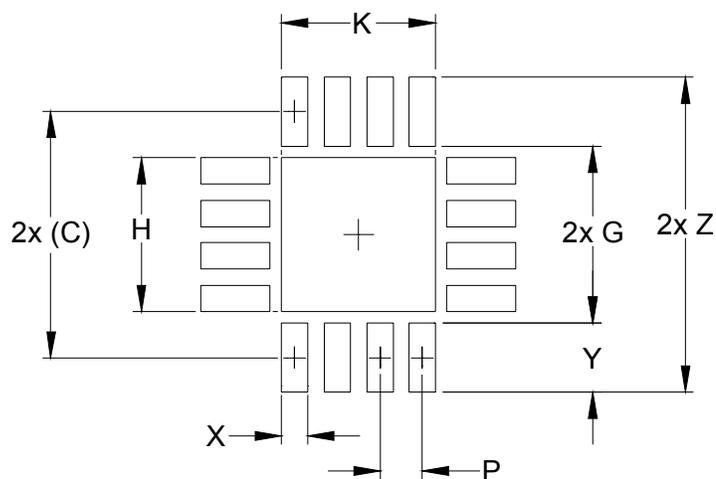

POWER MANAGEMENT
Land Pattern MLP-16 pin

DIMENSIONS		
DIM	INCHES	MILLIMETERS
C	(.148)	(3.75)
G	.106	2.70
H	.091	2.30
K	.091	2.30
P	.026	0.65
X	.016	0.40
Y	.041	1.05
Z	.189	4.80

NOTES:

1. THIS LAND PATTERN IS FOR REFERENCE PURPOSES ONLY. CONSULT YOUR MANUFACTURING GROUP TO ENSURE YOUR COMPANY'S MANUFACTURING GUIDELINES ARE MET.

Contact Information

Semtech Corporation
 Portable Power Management Products Division
 200 Flynn Rd., Camarillo, CA 93012-8790
 Phone: (805)498-2111 FAX (805)498-3804