



Dual N-Channel Enhancement Mode Field Effect Transistor

PRODUCT SUMMARY		
V _{SSS}	I _S	R _{SS(ON)} (mΩ) Max
30V	15A	8.5 @ V _{GS} =10V
		12 @ V _{GS} =4.5V

FEATURES

- Super high dense cell design for low R_{DS(ON)}.
- Rugged and reliable.
- Wafer level CSP.
- ESD Protected.

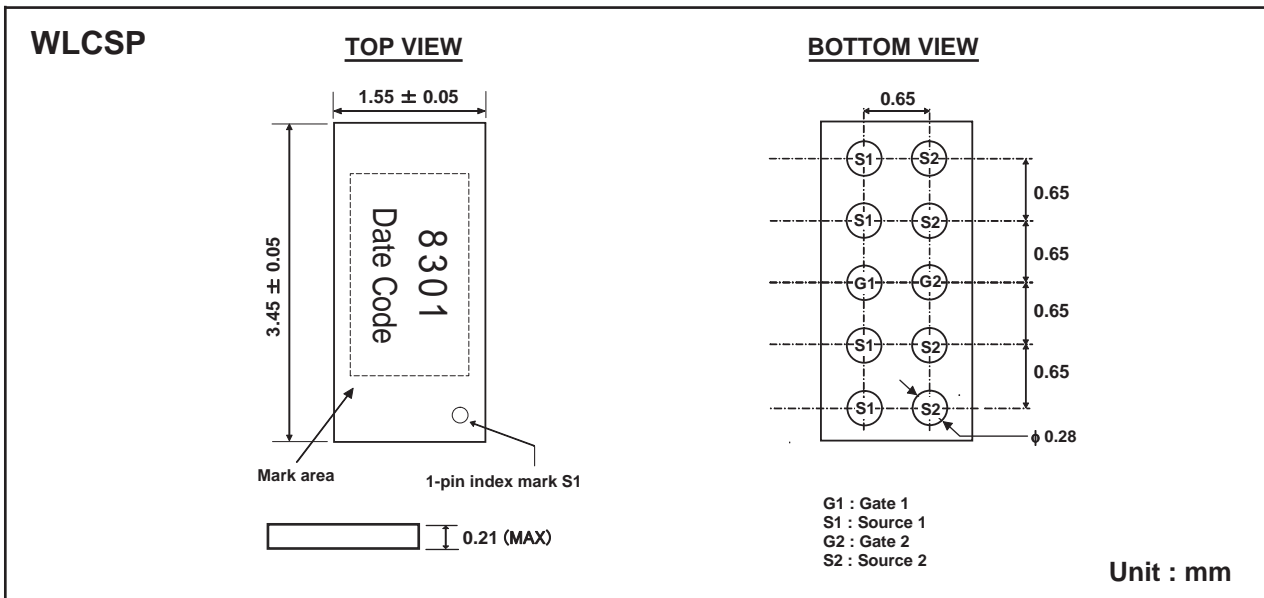

ABSOLUTE MAXIMUM RATINGS (T_A=25°C)

Symbol	Parameter	Limit	Units
V _{SSS}	Source-Source Voltage	30	V
V _{GSS}	Gate-Source Voltage	±20	V
I _S	Source Current-Continuous ^a	15	A
I _{SP}	-Pulsed ^b	120	A
P _T	Total Power Dissipation ^a	2.0	W
T _J , T _{STG}	Operating Junction and Storage Temperature Range	-55 to 150	°C

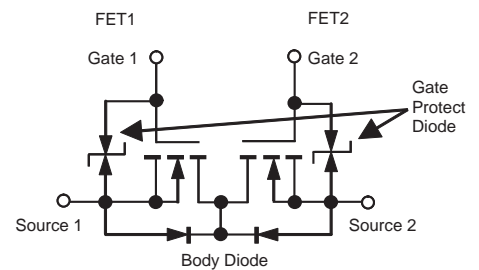

SC8301

Ver 1.0

ELECTRICAL CHARACTERISTICS (TA=25°C unless otherwise noted)

Symbol	Parameter	Conditions	Min	Typ	Max	Units
OFF CHARACTERISTICS						
BV _{SSS}	Source-Source Breakdown Voltage	V _{GS} =0V, I _S =250uA	30			V
I _{SSS}	Zero Gate Voltage Source Current	V _{SS} =30V, V _{GS} =0V			1	uA
I _{GSS}	Gate-Body Leakage Current	V _{GS} = ±16V, V _{SS} =0V			±10	uA
ON CHARACTERISTICS						
V _{GS(th)}	Gate Threshold Voltage	V _{SS} =V _{GS} , I _S =1mA	1.0	1.8	2.5	V
R _{SS(ON)}	Source-Source On-State Resistance	V _{GS} =10V, I _S =7.5A		7	8.5	m ohm
		V _{GS} =4.5V, I _S =7.5A		9	12	m ohm
DYNAMIC CHARACTERISTICS ^c						
C _{ISS}	Input Capacitance	V _{SS} =10V, V _{GS} =0V f=1.0MHz		2583		pF
C _{OSS}	Output Capacitance			369		pF
C _{RSS}	Reverse Transfer Capacitance			139		pF
SWITCHING CHARACTERISTICS ^c						
t _{D(ON)}	Turn-On Delay Time	V _{DD} =15V I _S =7.5A V _{GS} =10V		38		ns
t _r	Rise Time			151		ns
t _{D(OFF)}	Turn-Off Delay Time			484		ns
t _f	Fall Time			356		ns
Q _g	Total Gate Charge	V _{DD} =15V, I _S =15A, V _{GS} =4.5V		20.5		nC
DRAIN-SOURCE DIODE CHARACTERISTICS AND MAXIMUM RATINGS						
V _{FSS}	Diode Forward Voltage	V _{GS} =0V, I _S =4.5A		0.8	1.2	V
Note						
a. Mounted on FR4 board of 25.4mm x 25.4mm x 1.0mm.						
b. Pulse Test: Pulse Width < 10us, Duty Cycle < 1%.						
c. Guaranteed by design, not subject to production testing.						

Jan,14,2016

V_{SSS} / I_{SSS}

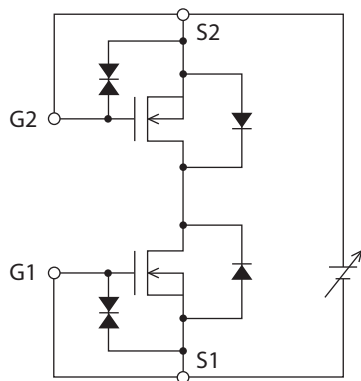

$I_{GSS} (+) / (-)$

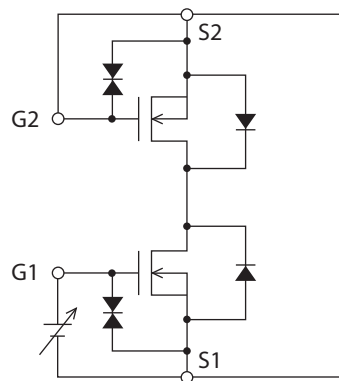

$V_{GS} \text{ (off)}$

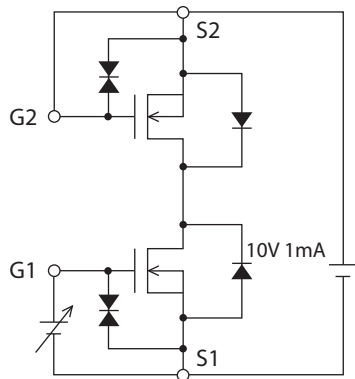

$|y_{fs}|$

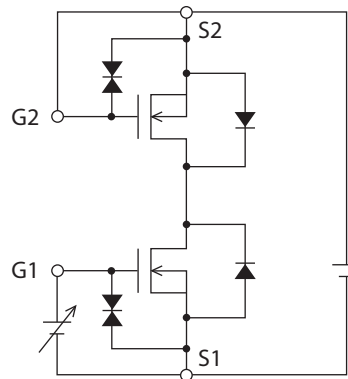

* Note: Connect the measurement terminal reversely if you want to measure the FET2 side.

SC8301

Ver 1.0

$R_{SS}(\text{on})$

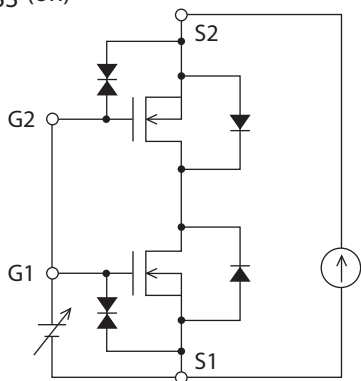

$V_F(S-S)$

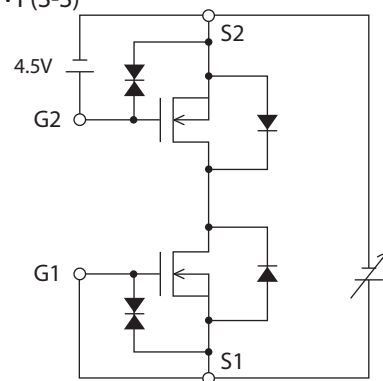

$t_d(\text{on}), t_r, t_d(\text{off}), t_f$

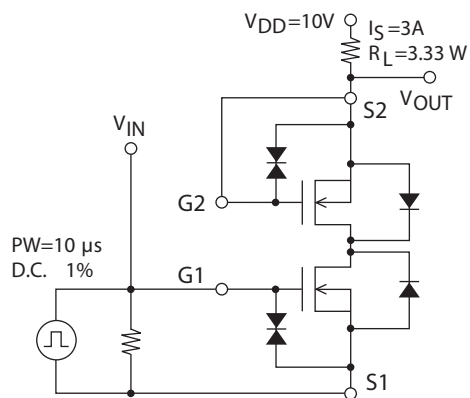

Q_g

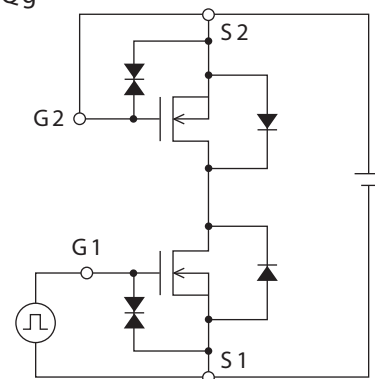

* Note: Connect the measurement terminal reversely if you want to measure the FET2 side.

Jan,14,2016

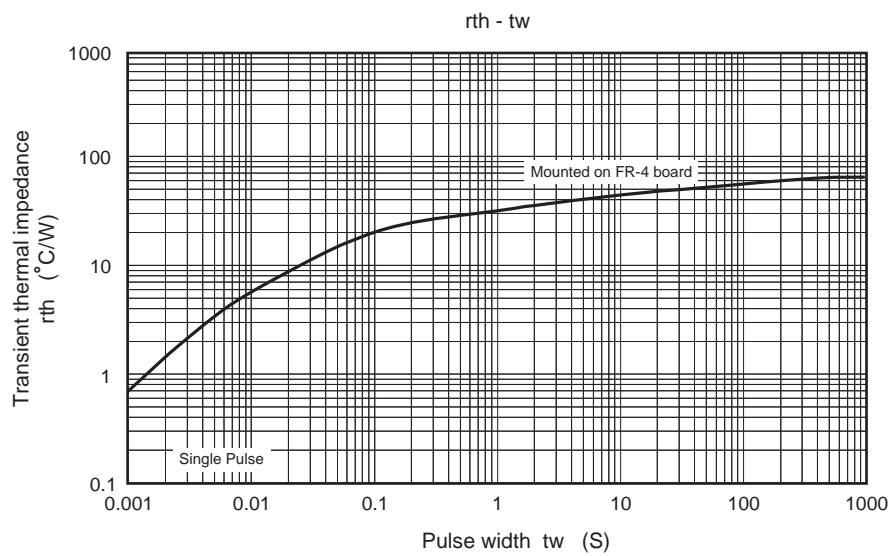
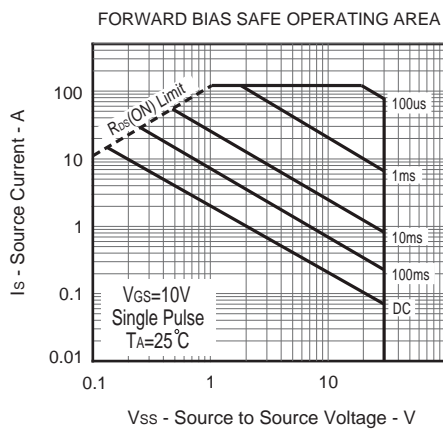
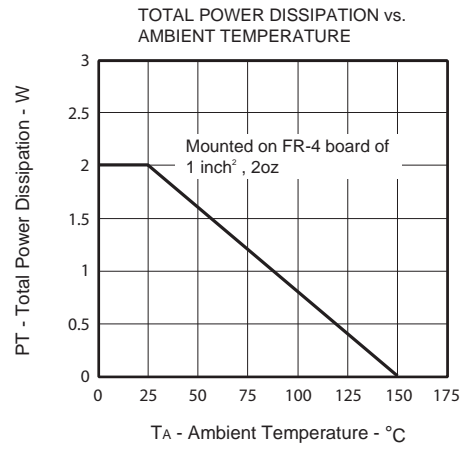
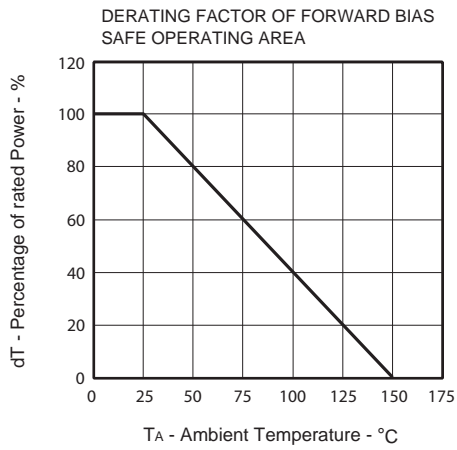

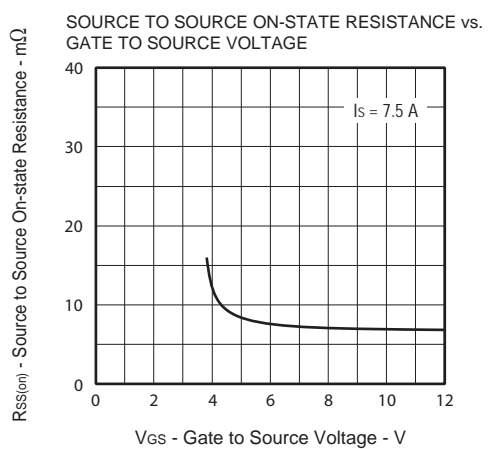
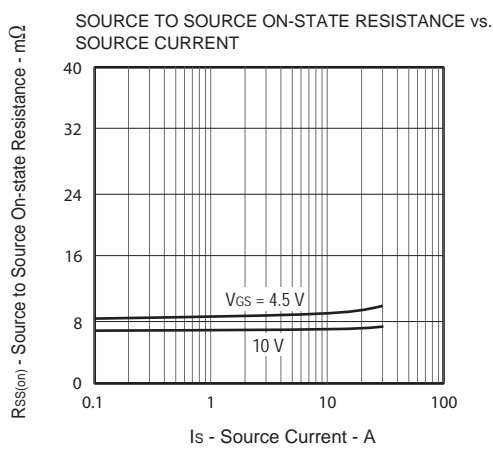
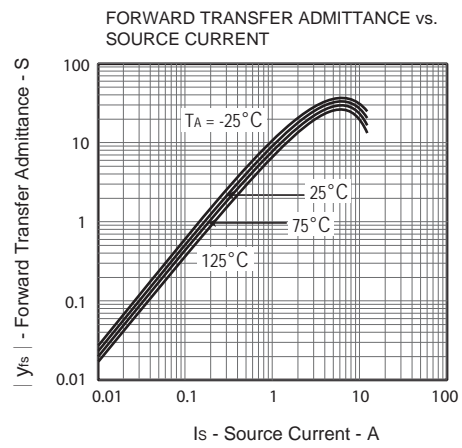
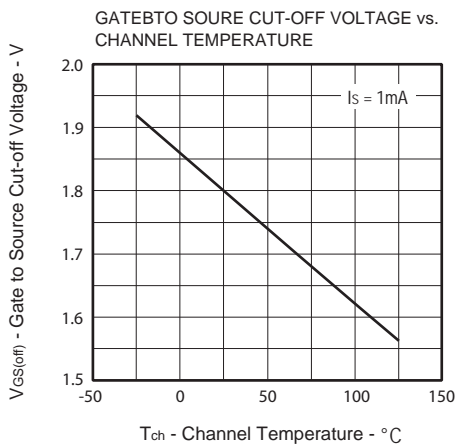
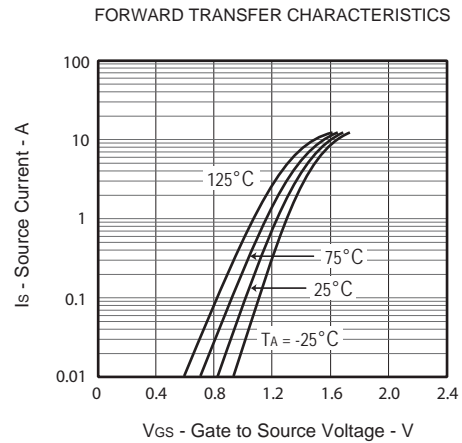
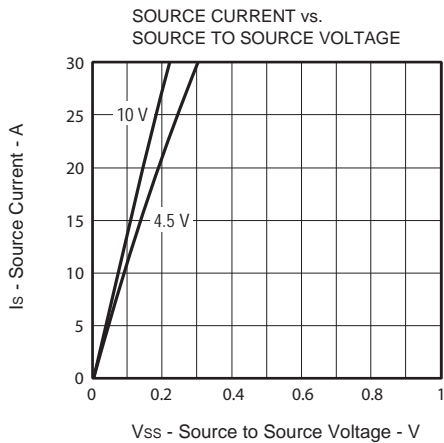

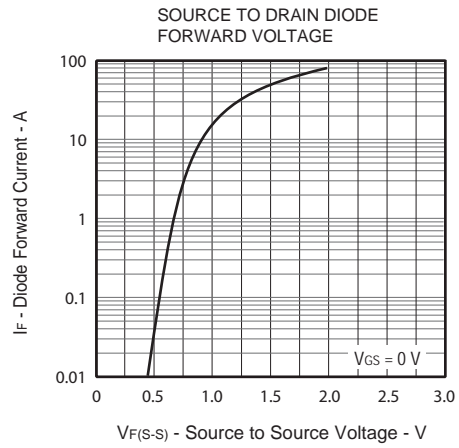
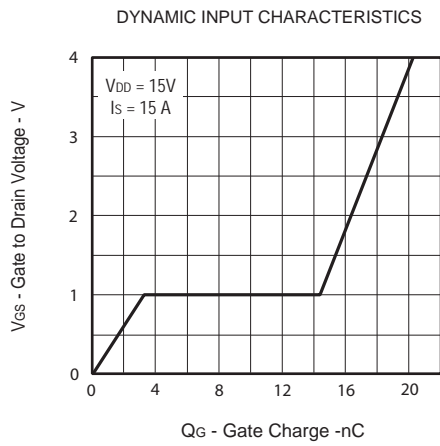
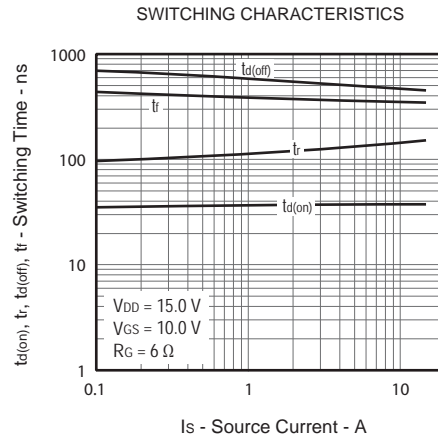
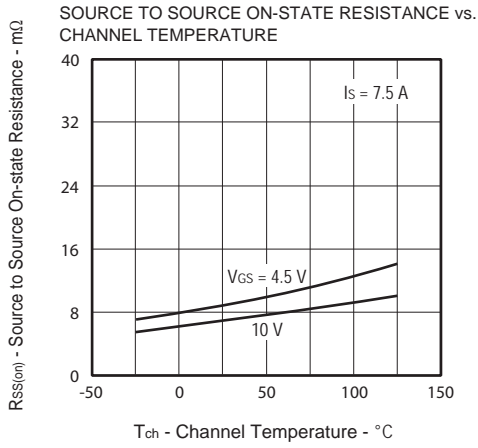

TOP MARKING DEFINITION

