

## TWO IN ONE SCROLLING MOUSE CONTROLLER

### DESCRIPTION

The SC84520 Scrolling Mouse Controller is specially designed to control serial mouse or PS/2 mouse device. This single chip can interface three key-switched and 4 X-Y photo-couples plus Z-axis directly plus Z-axis directly to RS-232C or 8042 controller.

There are four types Z-axis inputs used to implement scrolling mouse functionality.

### FEATURES

- \*Using  $50k\Omega \pm 1\%$  resistor for RC oscillation
- \*Compatible with legacy PS/2 mouse
- \*Compatible with Microsoft serial scrolling mouse
- \*Compatible with Microsoft PS/2 scrolling mouse
- \*Serial or PS/2 port auto-detect
- \*100 bytes PnP ID code could be filled by code layer
- \*Built-in noise immunity circuit
- \*The sampling rate of motion detector is up to 65 kHz
- \*Built-in three zener diodes : one in VDD to VSS, two in RTS to VDD
- \*CMOS push-pull RXD output
- \*Built-in current comparator for photo-couples input
- \*Built-in three step dynamic input impedance
- \*Three key-switches and four photo-coupled inputs
- \*RTS debouncing circuit include
- \*Photo couple test mode include
- \*Low power dissipation
- \*Six types Z direction input:
  1. Photo couples input (Z/1)
  2. Key-switches input
  3. Voltage-sensing input
  4. Mechanical input(Z/1)
  5. Photo couples input (Z/4)
  6. Mechanical input (Z/2)

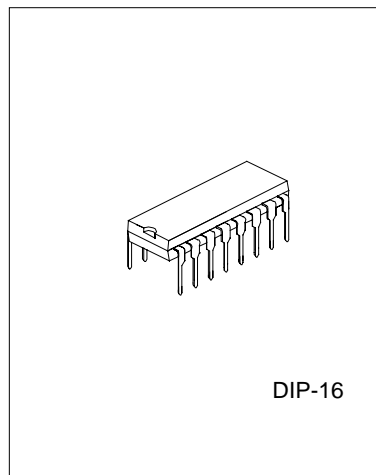

### \*Package type:

- SC84510AP: 16DIP, Photo coupled input(Z/1)
- SC84510BP: 16DIP, Key-switches input
- SC84510CP: 16DIP, Voltage-sensing Input
- SC84510DP: 16DIP, Mechanical input (Z/1)
- SC84510EP: 16DIP, Photo couples input (Z/4)
- SC84510FP: 16DIP, Mechanical input (Z/2)

### APPLICATIONS

- \*Serial PnP scrolling mouse
- \*PS/2 scrolling mouse
- \*Combo PnP scrolling mouse

**PIN CONFIGURATIONS**

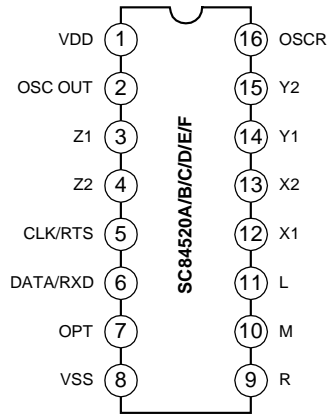

**BLOCK DIAGRAM**

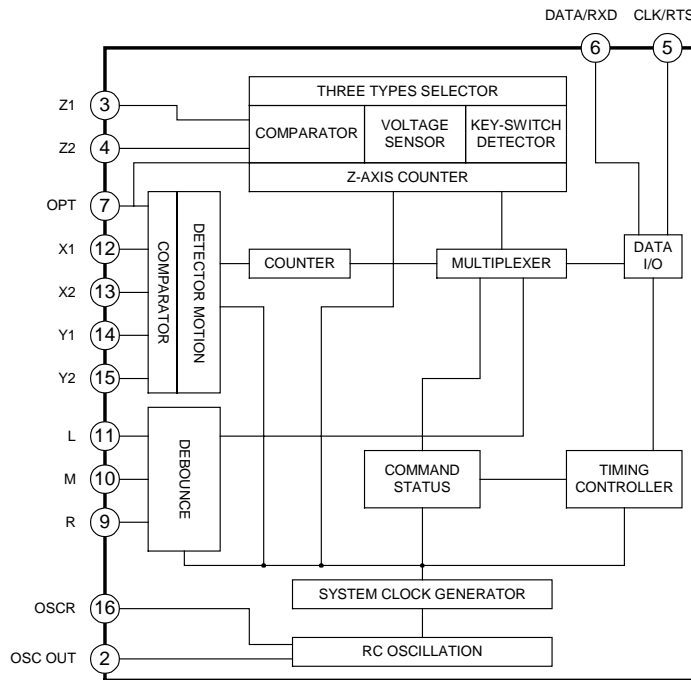

**ABSOLUTE MAXIMUM RATINGS** (Tamb=25°C, unless otherwise specified)

Characteristic	Symbol	Value	Unit
Supply Voltage	VSS	-0.3 ~ +7.5	V
Temperature Under Bias		0 ~ 70	°C
Storage Temperature range	T <sub>OPR</sub>	-65 ~ +150	°C
Power Dissipation	P <sub>D</sub>	500	mW

**DC ELECTRICAL CHARACTERISTICS** (Tamb=25~70°C)

Parameter	Symbol	Min	Typ	Max	Unit
Operating Voltage	V <sub>DD</sub>	--	--	6.5	V
Operating Current (V <sub>DD</sub> =5.4V, RTS=V <sub>DD</sub> , 32.768kHz, No Load)	I <sub>op</sub>	--	--	0.6	mA
Operating Current (V <sub>DD</sub> =6.2V, RTS=V <sub>DD</sub> , 32.768kHz, No Load)	I <sub>op</sub>	3	--	--	mA
Operating Current (V <sub>DD</sub> =5.4V, RTS=V <sub>DD</sub> , 3.58MHz, No Load)	I <sub>op</sub>	--	--	1.6	mA
Operating Current (V <sub>DD</sub> =6.2V, RTS=V <sub>DD</sub> , 3.58MHz, No Load)	I <sub>op</sub>	4	--	--	mA
RTS Operating Current (V <sub>DD</sub> =5.6V, RTS=11V)	I <sub>RTS</sub>	--	--	0.6	mA
RTS Operating Current (V <sub>DD</sub> =5.6V, RTS=11.8V)	I <sub>RTS</sub>	3	--	--	mA
RXD High Output Current (V <sub>rh</sub> =V <sub>rts</sub> -2.6V)	I <sub>rh</sub>	2.0	--	--	mA
RXD Low Output Current (V <sub>rl</sub> =V <sub>ss</sub> +2.6V)	I <sub>rl</sub>	--	--	-2.0	mA
X1,X2,Y1,Y2 Low Input Voltage	V <sub>pl</sub>	--	--	0.7	V
X1,X2,Y1,Y2 High Input Voltage	V <sub>ph</sub>	1.3	--	--	V
X1,X2,Y1,Y2 Input Current (Pull Low Resistor, V <sub>ds</sub> =1.0V)	I <sub>pi</sub>	57	--	104	μA
RTS High Input Voltage	V <sub>th</sub>	9.6	--	--	V
RTS Low Input Voltage	V <sub>tl</sub>	--	--	6.8	V
Low Input Voltage, Other Pins	V <sub>ail</sub>	--	--	1.5	V
High Input Voltage, Other Pins	V <sub>aih</sub>	3.5	--	--	V
L,M,R,OPT Input Current (Pull Low Resistor, V <sub>ds</sub> =5.6V)	I <sub>mi</sub>	18.6	--	56	μA
Rs,Osc-In,L,M,R,X1,X2,Y2,Y2,Opt Input Leakage Current (V <sub>in</sub> =0V)	I <sub>il</sub>	0	--	1.0	μA
RS, OSC-IN Input Leakage Current (V <sub>in</sub> =5.6V)	I <sub>ih</sub>	-1.0	--	0	μA

NOTE: \*All voltages in above table are compared with VSS.

\*All parameters in above table are tested under V<sub>DD</sub>=5.6V

## AC ELECTRICAL CHARACTERISTICS (Tamb=25~70°C)

PS/2 mouse mode:

Parameter	Symbol	Min	Typ	Max	Unit
Oscillating Frequency	Fosc	37-3%	37	37+3%	kHz
Key Debounce	Tkd	--	12	--	ms
Rising Edge Crossed Width	Tr	13.5	--	--	μs
Falling Edge Crossed Width	Tf	13.5	--	--	μs
Mouse CLK Active Time	Tmca	--	40.5	--	μs
Mouse CLK Inactive Time	Tmci	--	40.5	--	μs
Time that Mouse Sample DATA from CLK rising Edge	Tmdc	--	13.5	--	μs
System CLK Active Time	Tsca	--	40.5	--	μs
System CLK Inactive Time	Tsci	--	40.5	--	μs
Time from DATA Transition to Falling Edge of CLK	Tsdc	--	13.5	--	μs
Time from rising Edge of CLK to DATA Transition	Tscd	--	27	--	μs
Time to mouse Inhibit after the 11th CLK to ensure mouse does not start another Transmission	Tpi	0	--	50	μs

Serial mouse mode:

Parameter	Symbol	Min	Typ	Max	Unit
Oscillating Frequency	Fosc	32.4-3%	32.4	32.4+3%	kHz
Key Debounce	Tkd	--	13	--	ms
Rising Edge Crossed Width	Tr	15.4	--	--	μs
Falling Edge Crossed Width	Tf	15.4	--	--	μs
Transmission Time	Tmx	--	33.33	--	ms
Start bit time	Ts	--	833.3	--	μs
Data bit time	Td	--	833.3	--	μs
Stop bit time	Tp	--	833.3	--	μs
Mode code delay Time	Trd	11	--	14	ms

## PIN DESCRIPTION

Pin Name	I/O	Description
OPT	I/O	<p>INPUT: 200kΩ pull low to VSS.</p> <p>When OPT is connected to VDD, SC84520 will enter test mode. In test mode, L will be the output of X1, while M will be the output of X2. Toggling R key can change these output to be Y1, Y2 or Z1, Z2 respectively.</p> <p>OUTPUT: 2kHz Z-axis LED-driving source with A/D/E/F version.</p> <p>"1" = VDD, "0" = floating</p> <p>High duty is about 60μs.</p>
OSC OUT	O	The RC oscillation clock output. Or 3mA sink current output for X, Y photo emitters.
OSCR	I	Connect 50kΩ ± 1% precise resistor for oscillation.
CLK/RTS	I/O	Connect to 8024 auxiliary port CLK line in PS/2 mode or connect directly to RS232C RTS pin in serial mode. Auto-detect the operating port by this pin.
DATA/RXD	I/O	Connect to 8024 auxiliary port DATA line in PS/2 mode or connect directly to RS232C RXD pin in serial mode.
VSS	--	Negative power input.
R	I	Three key-switches inputs. 200kΩ resistor pull low. In Z-axis key mode, M key toggling can change the scrolling speed from low to high.
M	I/O	
L	I/O	
X1	I	<p>Three step dynamic input impedance. If OSC OUT is not connected to LEDs, the dynamic input impedance will be off.</p> <p>Use current comparator to measure photo-couples "ON", or "OFF".</p>
X2		
Y1		
Y2		
Z1	I	<p>Z-axis input.</p> <p>Photo mode: Three steps dynamic input impedance. Current comparator input.</p> <p>Key mode: 200kΩ resistor pull low. 7 levels increased by "M" key.</p> <p>Voltage mode: 200kΩ resistor pull low. 7 level voltage comparator.</p> <p>Mechanical mode: 13.2 kΩ resistor pull low, Current comparator input.</p>
Z2		
VSS		Negative power.
VDD		Power line.

**X1, X2, Y1, Y2 INPUT IMPEDANCE**

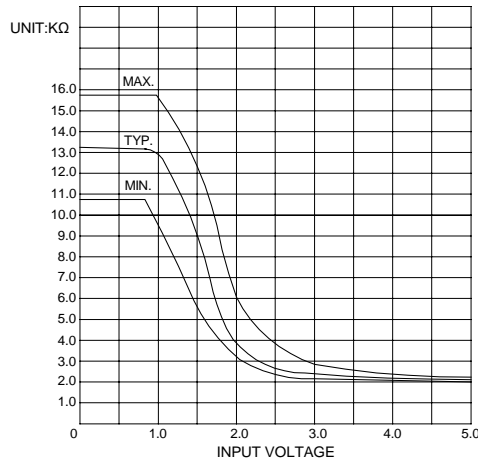

**FUNCTION DESCRIPTIONS**

**1.SERIAL SCROLLING MOUSE**

In Microsoft mode, the transmission cycle consists of four bytes in one report. Each byte contains one start bit, 7 data bits and two stop bits, The first byte contains “L”, “R” key status and four bits of the two most significant bits in horizontal counter and vertical counter. The second byte represents the value accumulated by horizontal counter, the third byte is the data of the vertical counter, The last byte contains “M” key status and Z-axis value. The vertical data is transmitted in 2’s complement.

Output byte arrange:

Bit No.	.....	6	5	4	3	2	1	0
<b>1st Byte</b>	.....	1	L	R	V7'	V6'	H7	H6
<b>2nd Byte</b>	.....	0	H5	H4	H3	H2	H1	H0
<b>3rd Byte</b>	.....	0	V5'	V4'	V3'	V2'	V1'	V0'
<b>4th Byte</b>	.....	0	0	M	Z3	Z2	Z1	Z0

Plug & Play ID code

When RTS input from low to high, SC84520 will send a string ID code. Customer can specify the contains of the code area and the total length below 100 bytes by changing the code layer.

Field Name	Length	Field Data	Description
Other ID	<17	4D, 5A, 40, 00..00, 00	ID for legacy
Begin ID	1	08	Begin PnP ID
PnP Revision	2	01, 24	Version 1.00
EISA ID	3	25, 2D, 23	EMC
Product ID	4	10, 10, 10, 11	0001
Serial Number	9	3C	None provided
Class ID	<34	3C, 2D, 2F, 35, 33, 25	Mouse Class
Driver ID	<42	3C, 30, 2E, 30, 10, 26, 10, 21	PnP0F0A
User Name	<42	3C, 25, 2D, 23, 00, 33, 23, 32, 2F, 2C, 2C, 29, 2E, 27, 00, 33, 25, 32, 29, 21, 2C, 00, 2D, 2F, 35, 33, 25	EMC SCROLLING SERIAL MOUSE
Check sum	2	21, 15	2 bytes check sum
End PnP	1	09	End PnP ID

## 2.LEGACY PS/2 MOUSE OPERATING:

### A) Operating Mode

There are four operating modes in PS/2 mouse:

#### a. Reset Mode:

In this mode a self-test is initiated during power-on or by a Reset command. After reset signal, PS/2 mouse will:

- (a) Send completion code AA & ID code 00.
- (b) Set default:
  - sampling rate: 100 reports/s
  - Non-autospeed
  - Stream mode
  - 2 dot/count
  - disable

#### b. Stream Mode:

The maximum rate of transfer is the programmed sample rate.

Data report is transmitted if

- (a) switch is pressed
- (b) movement has been detect

#### c. Remote Mode:

Data is transmitted only in response to a Read Data command.

d. Wrap Mode:

Any byte of data sent by the system. Except hex EC(Reset wrap mode) or hex FF (Reset) is returned by SC84520.

**B) PS/2 Mouse Data Report:**

- a. In stream mode: A data report is sent at the end of a sample interval.
- b. In remote mode: A data report is sent in response to Read Data command.
- c. Data report format:

Byte	Bit	Description
1	0	Left button status; 1 = pressed
	1	Right button status; 1 = pressed
	2	Middle button status; 1 = pressed
	3	Reserve
	4	X data sign; 1 = negative
	5	Y data sign; 1 = negative
	6	X data overflow; 1 = overflow
2	7	Y data overflow; 1 = overflow
	0-7	X data ( D0 – D7)
3	0-7	Y data ( D0 – D7)

**C) PS/2 Mouse Data Transmission:**

- a. SC84520 generates the clocking signal when sending data to and receiving data from the system.
- b. The system requests SC84520 receive system data output by forcing the DATA line to an inactive level and allowing CLK line to go to an active level.
- c. Data transmission frame:

Bit	Function
1	Start bit (always 0)
2-9	Data bits (D0 – D7)
10	Parity bit (odd parity)
11	Stop bit (always 1)

d. Data Output (data from SC84520 to system):

If CLK is low (inhibit status), data is no transmission.

If CLK is high and DATA is low (request –to–send), data is update. Data is received from the system and no transmission are started by SC84520 until CLK and DATA both high. If CLK and DATA both are high, the transmission is ready. DATA is valid prior to the falling edge of CLK and beyond the rising edge of CLK.

During transmission, SC84520 check for line contention by checking for an inactive level on CLK at intervals not to exceed 100µs, Contention occurs when the system lowers CLK to inhibit SC84520 output after



SC84520 has started a transmission. If this occurs before the rising edge of the tenth clock, SC84520 internal store its data in its buffer and returns DATA and CLK to an active level. If the contention does not occur by the tenth clock, the transmission is complete.

e. Data Input (from system to SC84520):

The system first check if SC84520 is transmitting data. If SC84520 is transmitting, the system can override the output forcing CLK to an inactive level prior to the tenth clock. If SC84520 transmission is beyond the tenth clock, the system receives the data. If SC84520 is not transmitting or if the system choose to override the output. The system force CLK to an inactive level for a period of not less than 100 $\mu$ s while preparing for output. When the system is ready to output start bit (0), it allows CLK go to active level. If request-to-send is detected, SC84520 clocks 11 bits, Following the tenth clock SC84520 checks for an active level on the DATA line, and if found, force DATA low, and clock once more. If occurs framing error, SC84520 continue to clock until DATA is high, then clocks the line control bit and request a resend. When the system sends out a command or data transmission that requires a response, the system waits for SC84520 to response before sending its next output.

**D) PS/2 Mouse Error Handling:**

- a. A Resend command (FE) following receipt of an invalid input or any input with incorrect parity.
- b. If two invalid input are received in succession, an error code of hex (FC) is send to the system.
- c. The counter accumulators are cleared after receiving any command except "Resend"
- d. SC84520 receives a Resend command (FE), it transmit its last packet of data.
- e. In the stream mode "Resend" is received by SC84520 following a 3-byte data packet transmission to the system. SC84520 resend the 3-byte data packet prior to clearing the counter.
- f. A response is sent within 25ms if
  - a) The system requires a response
  - b) An error is detected in the transmission
- g. If SC84520 is in the stream mode:
  - a) The system disables SC84520 before issuing any command requiring a response.
  - b) When a command requiring a response is issued by the system another command should not be issue until either the response is received or 25ms has passed.

**E) PS/2 Mouse Commands Description:**

There are 16 valid commands that transmits between the system and SC84520. The "FA" code is always the first response to any valid input received from the system other than a Set Wrap Mode or Resend command. The following table list the commands:

Hex Code	Command	SC84520 echo code
FF	Reset	FA.AA.00
FE	Resend	XX.(XX.XX)
F6	Set Default	FA
F5	Disable	FA
F4	Enable	FA
F3.XX	Set Sampling Rate	FA.FA
F2	Read Device Type	FA,00
F0	Set Remote Mode	FA
EE	Set Wrap Mode	FA
EC	Reset Wrap Mode	FA
EB	Read Data	FA.XX.XX.XX
EA	Set Stream Mode	FA
E9	Status Request	FA.XX.XX.XX
E8.XX	Set Resolution	FA,FA
E7	Set Auto-speed	FA
E6	Reset Auto-speed	FA

The following describes valid commands:

a. Reset (FF)

SC84520 operation:

- a) Completion the reset.
- b) Transmitted FA, AA, 00 to the system.
- c) Set Default:

Sampling rate: 100 reports/s

Non-autospeed

Stream mode

2 dots/count

disable

b. Resend (FE)

- a) Any time SC84520 receives an invalid data. It returns a Resend command to the system.
- b) When SC84520 receives a Resend command, it retransmits its last packet of data. If the last packet was a Resend command, it transmits the packet just prior to the Resend command.
- c) In stream mode, if a Resend command is received by SC84520 immediately following a 3-byte data packet transmission to the system.

c. Set Default (F6)

The command reinitializes all conditions to the power-on defaults.

d. Disable (F5)

This command is used in the stream mode to stop transmissions from SC84520.

e. Enable (F4)

Begins transmissions, if in stream mode.

f. Set Sampling Rate (F3, XX)

In the stream mode, this command sets the sampling rate to the value indicated by byte hex XX. Shown in following:

Second byte XX	Sample Rate
0A	10/sec
14	20/sec
28	40/sec
3C	60/sec
50	80/sec
64	100/sec
C9	200/sec

g. Read Device Type (F2)

SC84520 always echoes "FA,00" following this command.

h. Set Remote Mode (F0)

Data value are reported only in response to a Read Data command.

i. Set Wrap Mode (EE)

Wrap mode remains until Reset (FF) or Reset Wrap Mode (EC) is received.

j. Reset Wrap Mode (EC)

SC84520 returns to the previous mode of operation after receiving this command.

k. Read Data (EB)

This command is executed in either remote or stream mode. The data is transmitted even if there has been no movement since the last report or the button status is unchanged. Following a Read Data command the registers are cleared after a data transmission.

h. Set Stream Mode (EA)

This command sets SC84520 in stream mode.

I. Status Request (E9)

When this command is issued by the system, SC84520 respond with a 3-byte status report as follows:

Byte	Bit	Description
1	0	1 = Right button pressed
	1	1 = Middle button pressed
	2	1 = Left button pressed
	3	Reserved
	4	0 = Normal speed, 1 = Autospeed
	5	0 = Disabled, 1 = Enable
	6	0 = Stream mode, 1 = Remote mode
	7	Reserved
2	0-7	Current resolution setting (D0 – D7)
3	0-7	Current sampling rate (D0 – D7)

m. Set Resolution (E8, XX)

SC84520 provides four resolutions selected by the second byte of this command as follows:

Second Byte XX	Resolution
00	8 dots/count
01	4 dots/count
02	2 dots/count
03	1 dot/count

n. Set Autospeed (E7)

At the end of a sample interval in the stream mode, The current X and Y data values are converted new values. The sign bits are not involved in this conversion. The conversion is only in stream mode. The relationship between the input and output count follows:

Input	Output
0	0
1	1
2	1
3	3
4	6
5	9
N(≥6)	2.0*N

o. Reset Autospeed (E6)

This command restore normal speed.

### 3.MICROSOFT OPS/2 SCROLLING MOUSE MODE:

**A) Entering procedure:** Except in WRAP mode, While SC84520 received the following consecutive command.

- a. F3 C8 ---- set sampling rate 200/sec
- b. F3 64 ---- set sampling rate 100/sec
- c. F3 50 ---- set sampling rate 80/sec

**B) Operating:**

- a. All of the command in legacy mode still be valid.
- b. The ID code of read device type command (F2) will changed from "00" to be "03".
- c. Data report will be four bytes format:

Byte	Bit	Description
1	0	Left button status; 1 = pressed
	1	Right button status; 1 = pressed
	2	Middle button status; 1 = pressed
	3	Reserve
	4	X data sign; 1 = negative
	5	Y data sign; 1 = negative
	6	X data overflow; 1 = overflow
	7	Y data overflow; 1 = overflow
2	0 - 7	X data (D0 – D7)
3	0 - 7	Y data (D0 – D7)
4	0 - 7	Z data (D0 – D7)

**C) Exiting Microsoft scrolling mode:**

There are two ways to exit:

- a. Power off.
- b. Reset command (FF).

**4.Z-AXIS INPUT FUNCTION:**

- a. Photo couples input: Z-axis counter accumulates the Z1, Z2 phase changed by movement.
- b. Key-switches input: Pressing Z1, Z2 will start to fill the Z-axis counter with the value beginning at one. Toggling "M" key can increase the value any time by one. The limit value is  $\pm 7$ .
- c. The relationship between the value and the transmission rate as follows:

Value	Rate per second
1	2.7
2	6.4
3	9.2
4	12.8
5	15
6	18
7	20

- d. Voltage-sensing mode: There are 7 voltage levels in Z1, Z2 input. The transmission table is the same as key-switch mode. The relationship between the value of Z-axis counter and the voltage as follows:

Value	Voltage
0	1V ↓
1	1.0V – 1.6V
2	1.6V – 2.2V
3	2.2V - 2.8V
4	2.8V – 3.4V
5	3.4V – 4.0V
6	4.0V – 4.6V
7	4.6V ↑

Under VDD = 5V condition

- e. Mechanical mode: The same as optical wheel mode.

**TIMING DIAGRAM**

(A) PS/2 mouse mode:

(A) Photo-couples pulse width

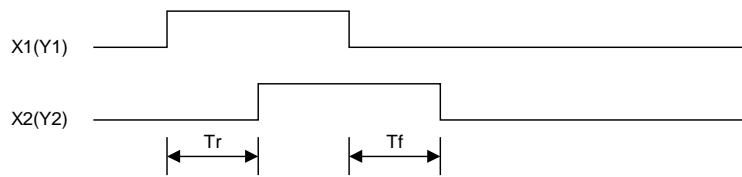

(B) Receiving Data

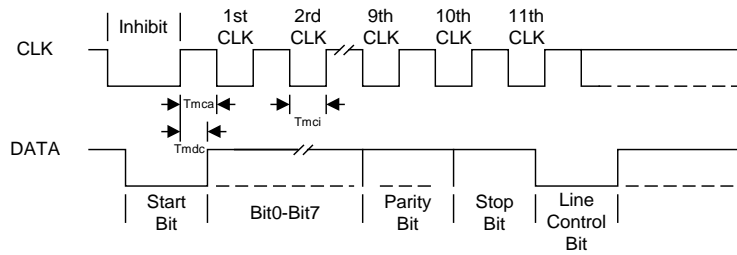

(C) Sending Data

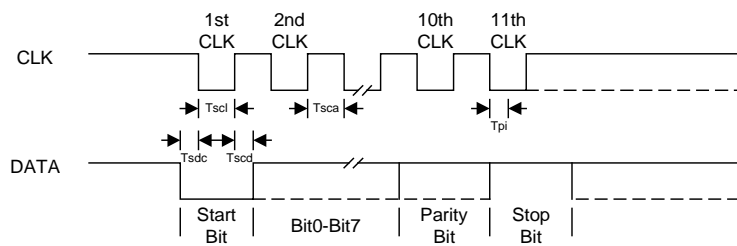

(B) Serial mouse mode:

(A) RXD output

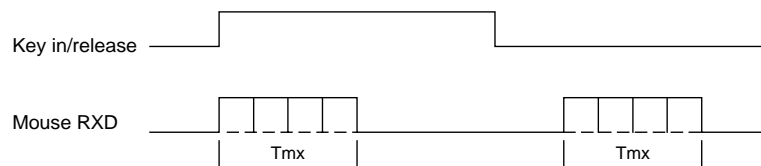

(B) Byte structure

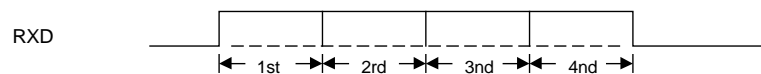

(C) Bits structure

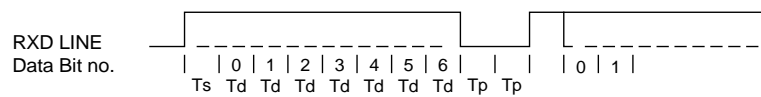

(D) PnP ID code echo timing

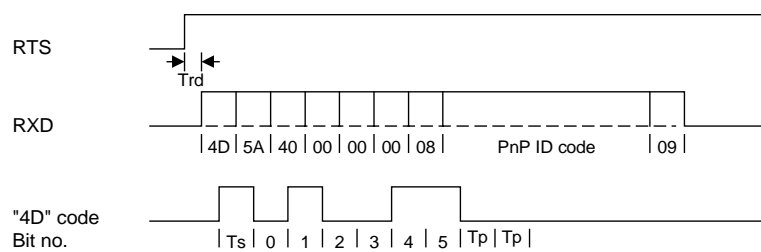



**APPLICATIONS CIRCUITS**

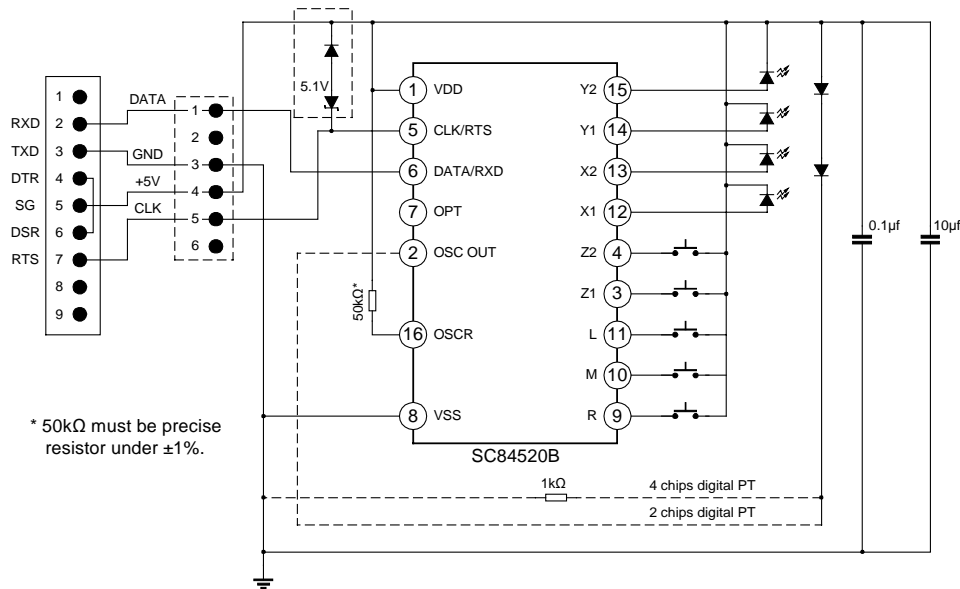
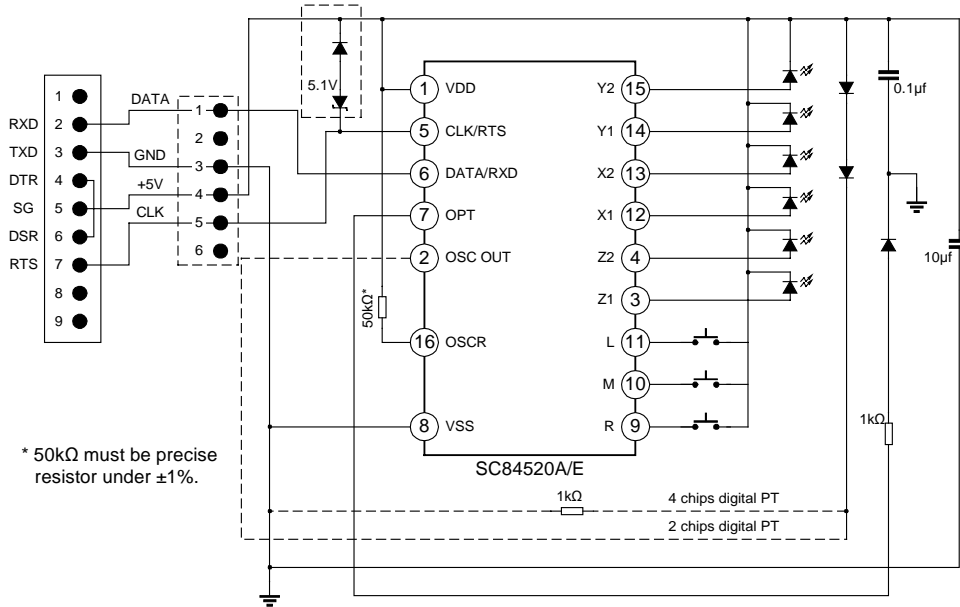

**APPLICATIONS CIRCUITS (continued)**

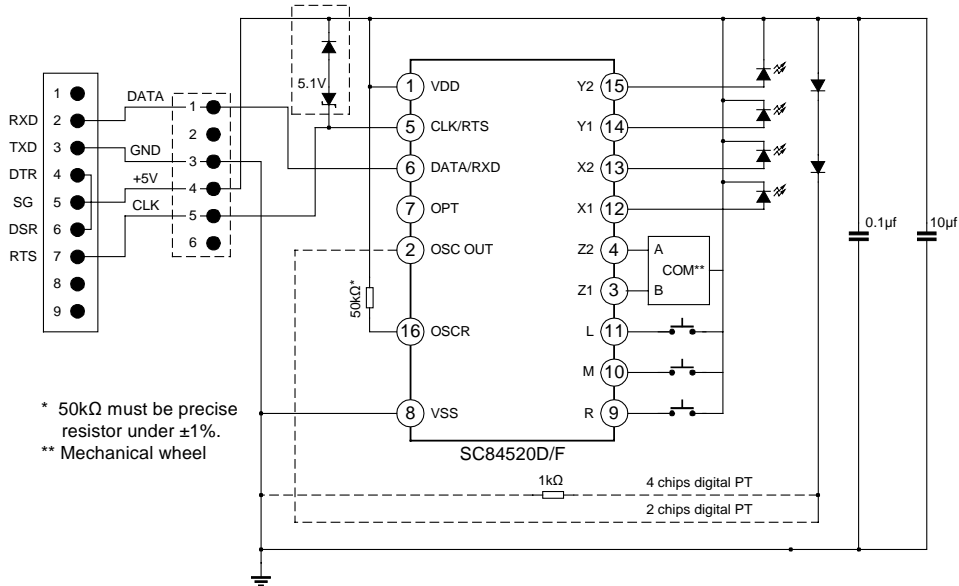
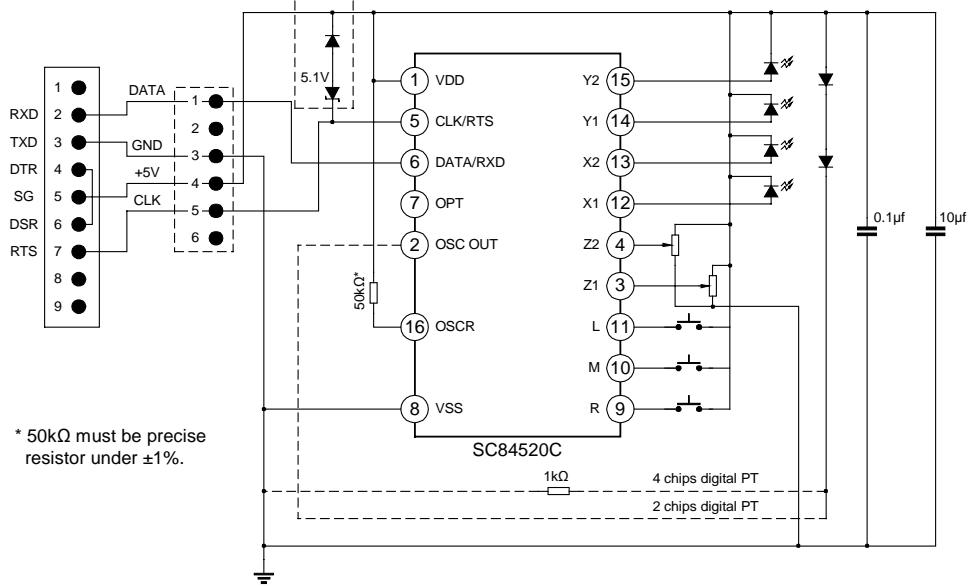

**PACKAGE OUTLINE**

