

## DIGITAL ALARM CLOCK WITH LED DRIVER

### DESCRIPTION

The SC8560 is an alarm equipped digital clock IC with built-in drivers capable of directly driving LED display equipment.

### FEATURES

- \* Single chip P-channel ED MOS LSI
- \* LED direct drive using time division (duplex configuration)
- \* Wide operating power supply voltage range
- \* Built-in alarm function with 24-hour control
- \* Supports changeover between 12-hour AM/PM and 24-hour displays
- \* Built-in battery backup CR oscillator
- \* Built-in automatic fast forward function for hour and minute settings
- \* Built-in snooze function supporting repeat use
- \* Uses 50Hz as standard frequency
- \* Built-in sleep timer function (maximum intervals for 59 minutes or 1 hour and 59 minutes)
- \* Equipped with power failure display function
- \* 900Hz output for alarm tone

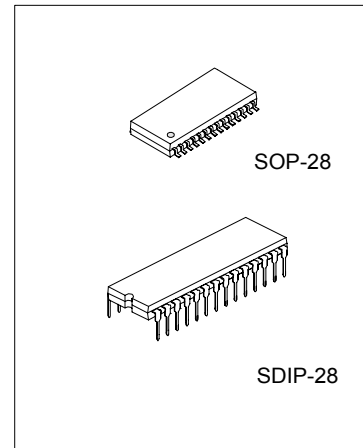

### ORDERING INFORMATION

Part No.	Package
SC8560	SDIP-28-400-1.778
SC8560S	SOP-28-375-1.27

### APPLICATIONS

- \* Alarm clocks
- \* Clock-radios

**BLOCK DIAGRAM**

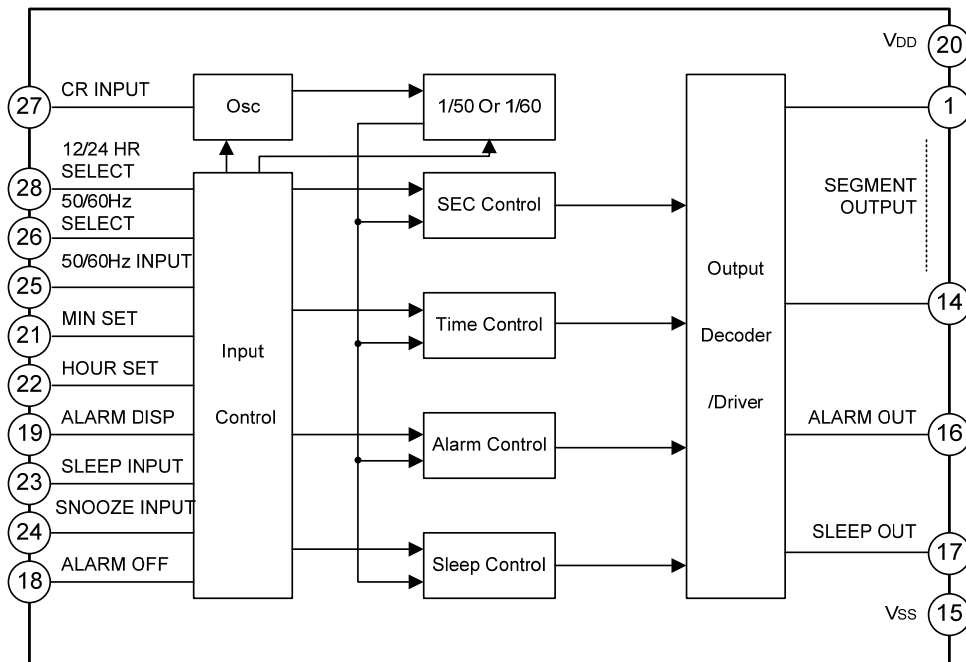

**ABSOLUTE MAXIMUM RATINGS** (Ta =25°C, Vss =0V)

Characteristics	Symbol	Condition	Value	Unit
Maximum Supply Voltage	VDD max.		-15.0 ~ + 0.3	V
Input Voltage 1	VIN(1)	50/60Hz input	-15.0 ~ + 0.3	V
Input Voltage 2 (except pin 26)	VIN(2)	Except 50/60Hz input	-15.0 ~ + 0.3	V
Output Voltage	VOU		-15.0 ~ + 0.3	V
Input Clamp current( pin 26)	IIN	50/60Hz input	-0.4 ~ +0.4	mA
Allowable Power Dissipation	PD	Ta=70°C	700	mW
Operating Temperature	Topr		-30 ~ +70	°C
Storage Temperature	Tstg		-55~+125	°C

**ELECTRICAL CHARACTERISTICS** (Tamb=25°C, VDD=-12.0V, VSS=0V, Unless otherwise specified)

Characteristics	Symbol	Test conditions	Min	Typ	Max	Unit
Supply Voltage	VDD		-14.0		-7.5	V
Input "H" level Voltage	VIH(1)	50/60Hz Input	-1.0			V
Input "L" level Voltage	VIL(1)	50/60Hz Input			VDD+2	V
Input "H" level Voltage	VIH(2)	Except 50/60Hz input	-1.5			V
Input "L" level Voltage	VIL(2)	Except 50/60Hz input			VDD+2	V
50/60 Hz input pin input voltage	VAC-IN		VLED			V
Input "H" level current(1)	IiH1	50/60Hz Input, VIN=VSS			10	µA

(To be continued)

(Continued)

Characteristics	Symbol	Test conditions	Min	Typ	Max	Unit
Input "L" level current(1)	IIL1	50/60Hz Input, VIN=VDD			10	μA
Input "H" level current(2)	IIH2	Input pins other than 50/60Hz Input, VIN=VSS			20	μA
Input "L" level current(2)	IIL2	Input pins other than 50/60Hz Input, VIN=VDD			10	μA
Output "H" level current(1)	IOH1	Alarm output and sleep output, VOH=VSS-1V	5			mA
Output leakage current(1)	IOF1	Alarm output and sleep output, VOUT=VDD			10	μA
Output "H" level current(2)	IOH2	AM& 10'S HR ag&de (24H mode),VOUT=VDD-1V	36			mA
Output leakage current(2)	IOF2	AM& 10'S HR ag&de (24H mode),VOUT=VDD			20	μA
Output "H" level current(3)	IOH3	Segment Output other than those listed above , VOUT=Vss-1V	18			mA
Output leakage current(3)	IOF3	Segment Output other than those listed above, VOUT=VDD			20	μA
Power failure detection voltage	VDF		-7.5	-5.0		V
Consumption current	ICC	Output set to off and pull-down attached input set to open		5	7	mA
Backup oscillator stability factor	fs	Standard value,900Hz, VDD= -9V±10%	-10		10	%
Backup oscillator accuracy	fa	Standard value,900Hz, VDD= -9V	-10		10	%

## PIN CONFIGURATIONS

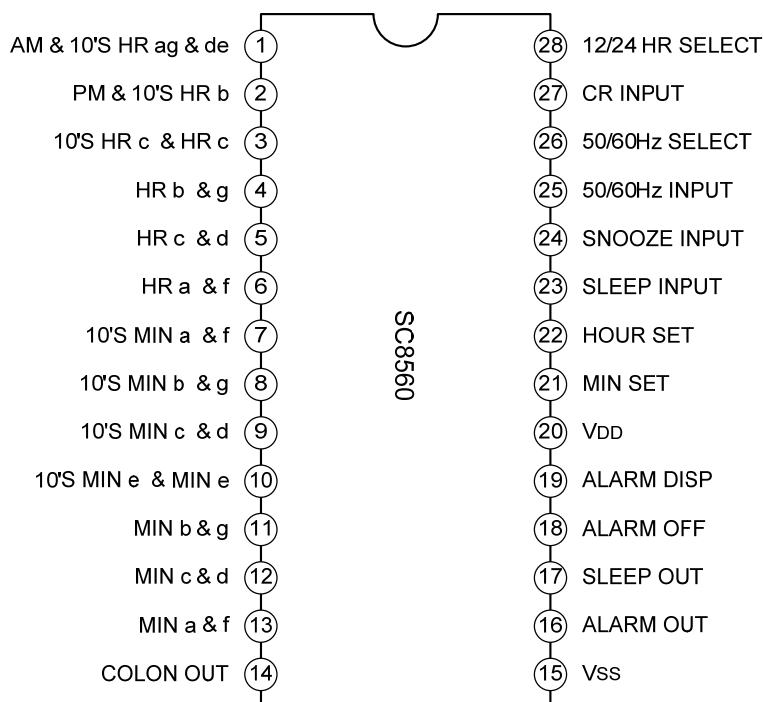

**DESCRIPTION OF OPERATIONS**

Terminal Description	Operating Description
50/60 Hz Input:	Built-in Shumidt circuits enable noise elimination at 50/60Hz commercial frequencies with use of a simple CR filter. Built-in pull-up resistor.
CR Input	When the AC power supply is interrupted, the time counter switches to a holding state and a built-in oscillator promptly begins operation. If 50/60Hz input continuous for 3 clocks without arriving, this oscillator's output is activated and functions as the time counter clock in place of 50/60Hz input. The frequency level of this clock oscillator is determined according to the CK Value. While the above mentioned oscillator is operating using backup mode, all segment output is switched to OFF. (Note) When the backup oscillator is in use due to an AC power supply interruption, the 50/60Hz input pin must be maintained open or at a Vss level.
50/60Hz Selective Input	When 50/60 selective input is connected to Vss,50Hz use is enable. When 50/60 selective input is left open, VDD is activated using an internal pull-down resistor and the setting is switched to enable use at 60Hz.
Display Mode Selective Input (Alarm Select/Sleep Select )	Since the pull-down resistor is built-in, selection from four display modes is possible using two SPST switches (single-pole and single-throw switches). Table I shows these display mode selections.
Time Setting Input	There are two setting inputs for use with "hour" and "minute". Time content settings shown in Table 2 are possible by activating Vss to these pins. A pull-down resistor is built-in.
12/24H Select Input	Leaving this pin unconnected (VDD) causes the 12-hour basis to be selected, connecting this pin to VSS cause the 24-hour basis to be selected .An internal pull-down resistor is provided.
Power Failure Detection display	If the power supply voltage drops and is applied again, all the on-segments flash and the power failure indication mode is entered. The power failure indication mode is released by applying VSS to "hour set" or " minutes set".
Alarm Operation and Alarm Output	The alarm signal outputs when alarm content marches the time .When not reset by either snooze input or alarm off input, output continues after 1 hour and 59 minutes. This output signal consists of 900 Hz 2 Hz intermittent (50% duty) modulation signals. When the need arises, a filter can be applied to alter the alarm signal to a DC signal.
Snooze Input	When the alarm is sounding and instantly activating Vss to this pin, alarm output is set to OFF for a period between 8 and 9 minutes after which time the alarm signal is once again output .The snooze function can be used repeatedly in 1 hour and 59 minutes intervals. A pull-down resist is built-in. Activating Vss to the snooze pin when the alarm is OFF resets the sleep timer counter to [0:00].(This is known as the one-touch sleep timer reset function.)
Alarm Off Input	Activating this input pin to Vss instantly sets alarm output to OFF. A pull-down resistor is built-in.
Sleep Timer and Sleep Output:	Sleep output can turn on the radio and can be set for time intervals of 59 minutes or 1 hour and 59 minutes. Refer to Table 2 for the proper selection procedure (59 minutes or 1 hour and 59 minute selection). This sleep timer is constructed using a down counter and when the counter content arrives at [00], output is set to off and the radio turns off .Adding Vss to snooze input turns sleep output off, when sleep output is on.

**TABLE 1: DISPLAY MODES**

Selective Input		Display Mode	Digit No.1	Digit No.2	Digit No.3	Digit No.4
Alarm	Sleep					
NC	NC	Time display	10's place for hour ,AM/PM	Hour	10's place for minute	Minute
Vss	NC	Alarm display	10's place for hour ,AM/PM	Hour	10's place for minute	Minute
NC	Vss	Sleep display	--	Hour	10's place for minute	Minute
Vss	Vss	Second display	Clear	Minute	10's place for second	Second

**Note:** Activating Vss using two inputs simultaneously (alarm select and sleep select), the display mode is switched to display seconds.

**TABLE 2: SETTING CONTENTS**

Display Mode	Set Input	Functions
Time	HOUR	Immediately adds 1 to hour digits and then assigns an additional 1. at a speed of 2 Hz , after each 1/4 to 3/4 second .
	MIN	Immediately adds 1 to minute digits and then assigns an additional 1. at a speed of 2 Hz, after each 1/4 to 3/4 second . Seconds are reset.
	BOTH	Operates both as outline above.
Second (Alarm&Sleep)	HOUR(Note)	Second digits are cleared to [00].
	MIN	Time holds.
	BOTH	Resets hour and minute digits as [0:00] when operating in 24-Hmode or [12:00] when operating in 12-H mode.
Alarm	HOUR	Immediately adds 1to hour digits and then assigns an additional 1, at a speed of 2 Hz, after each 1/4to 3/4 second.
	MIN	Immediately adds 1 to minute digits and then assigns an additional 1, at a speed of 2 Hz, after each 1/4to 3/4 second.
	BOTH	Resets hour and minute digits to [0:00] when operating in 24-hour mode or [12:00] when operating in, 12-hour mode.
Sleep	-	Sets sleep counter to [0:59] instantly when VDD is activated to sleep select.
	HOUR	Sets sleep counter to [1:59] instantly when VDD is activated to sleep select and hour at the same time.
	MIN	Sleep counter loses 1 at a speed of 2 Hz
	BOTH	Sleep counter loses 1 at a speed of 2 Hz

Once conditions have been switched to reset or hold, input of other functions is locked until HOUR and MIN input have separated.

**Note:**

When the digital reading for seconds is between 30 and 59 seconds, 1 is added to digits for minutes as the digital reading for seconds resets to [00]

CLOCK-RADIO APPLICATION CIRCUIT (Positive Power Supply)

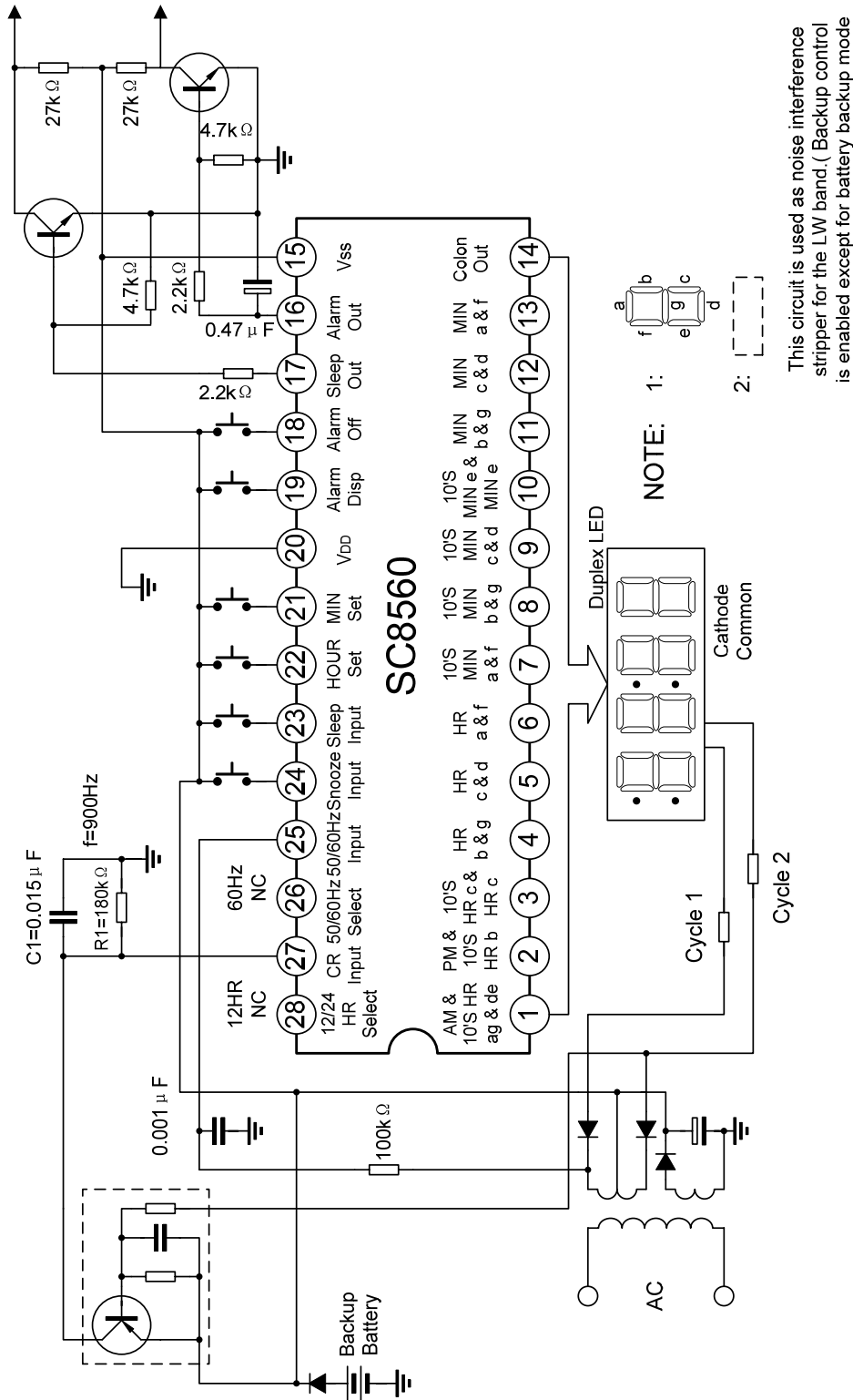

12 Hour Display and 60Hz Circuit Diagram

CLOCK APPLICATION CIRCUIT (Negative Power Supply)

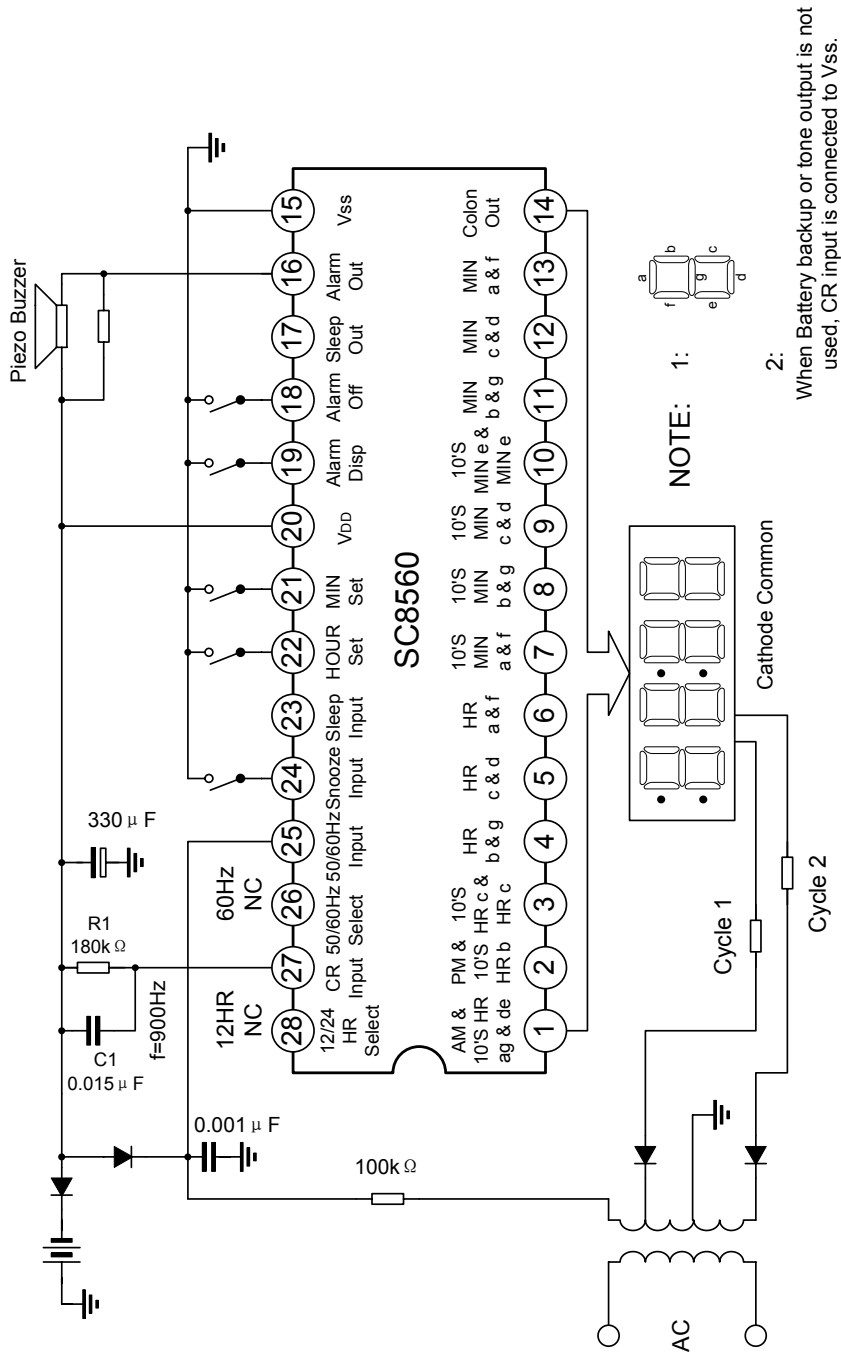

12 Hours Display and 60Hz Circuit diagram

PACKAGE OUTLINE

SDIP-28-400-1.778

UNIT: mm

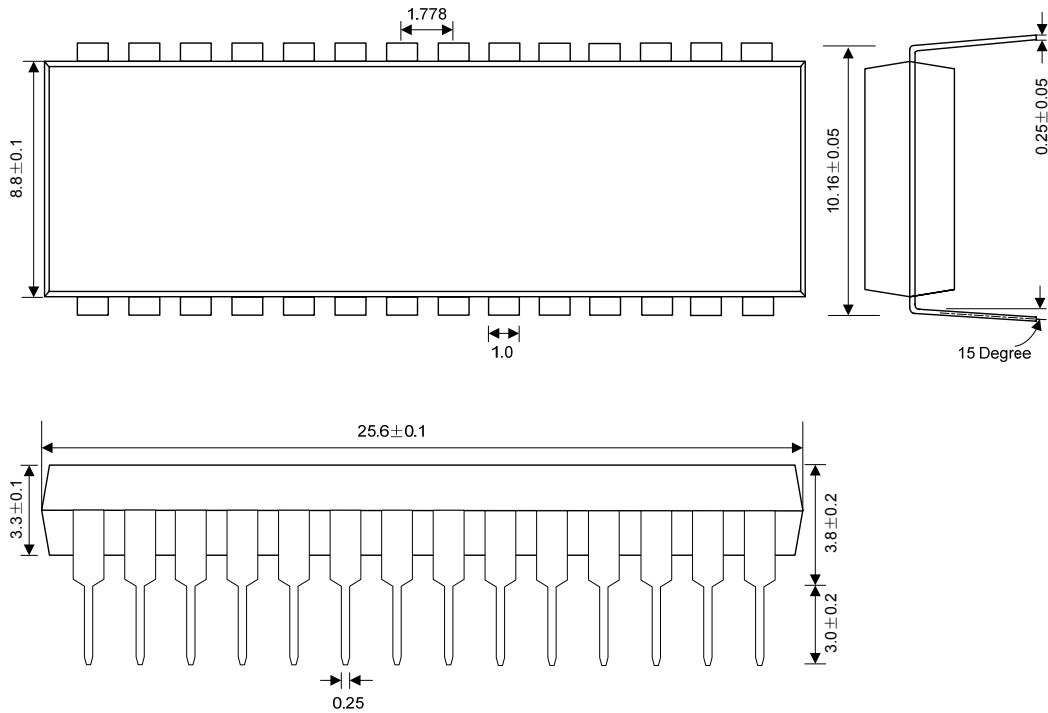

SOP-28-375-1.27

UNIT: mm

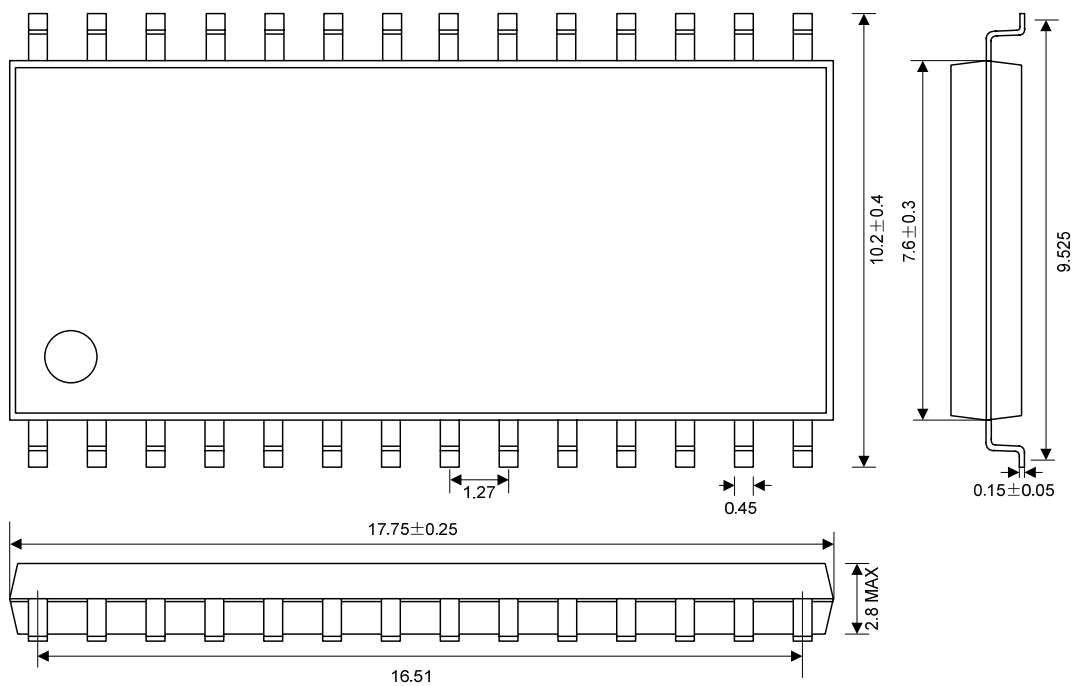





#### MOS DEVICES OPERATE NOTES:

Electrostatic charges may exist in many things. Please take following preventive measures to prevent effectively the MOS electric circuit as a result of the damage which is caused by discharge:

- The operator must put on wrist strap which should be earthed to against electrostatic.
- Equipment cases should be earthed.
- All tools used during assembly, including soldering tools and solder baths, must be earthed.
- MOS devices should be packed in antistatic/conductive containers for transportation.

Note: Silan reserves the right to make changes without notice in this specification for the improvement of the design and performance. Silan will supply the best possible product for customers.



ATTACHMENT

Revision History

Data	REV	Description	Page
2000.12.31	1.0	Original	
2008.06.02	1.1	Modify the "CLOCK-RADIO APPLICATION CIRCUIT (Positive Power Supply)" and "CLOCK APPLICATION CIRCUIT (Negative Power Supply)".	