

March 1, 2000

TEL:805-498-2111 FAX:805-498-3804 WEB:http://www.semtech.com

## DESCRIPTION

The SC8863 is a low dropout linear regulator that operates from a +2.5V to +5.5V input range and delivers up to 150mA. A PMOS pass transistor allows the low 110 $\mu$ A supply current to remain independent of load, making these devices ideal for battery operated portable equipment such as cellular phones, cordless phones and personal digital assistants.

The SC8863 output voltage can be preset or adjusted with an external resistor divider. Other features include low powered shutdown, short circuit protection, thermal shutdown protection and reverse battery protection. The SC8863 comes in the tiny 5 lead SOT-23 package.

## FEATURES

- Guaranteed 150 mA output current
- Fixed or adjustable output
- Very small external components
- Low 75 $\mu$ V<sub>RMS</sub> output noise
- Very low supply current
- Thermal overload protection
- Reverse battery protection
- Low power shutdown
- Surface mount packaging (5 pin SOT-23)
- Full industrial temperature range

## APPLICATIONS

- Battery Powered Systems
- Cellular Telephones
- Cordless Telephones
- Personal Digital Assistants
- Portable Instrumentation
- Modems
- PCMCIA cards

## BLOCK DIAGRAM

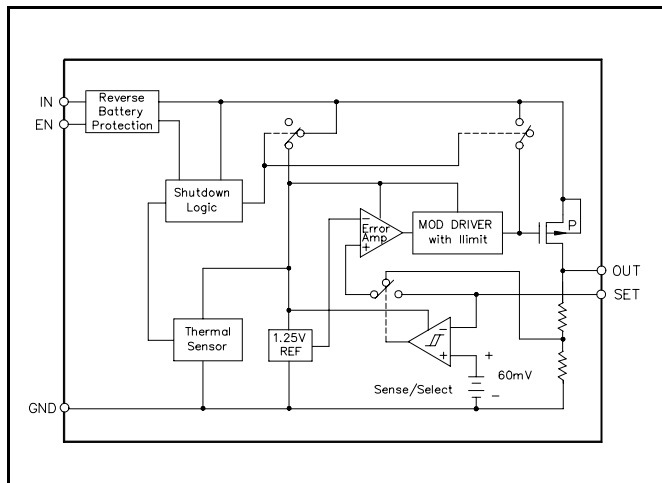

## PIN CONFIGURATION

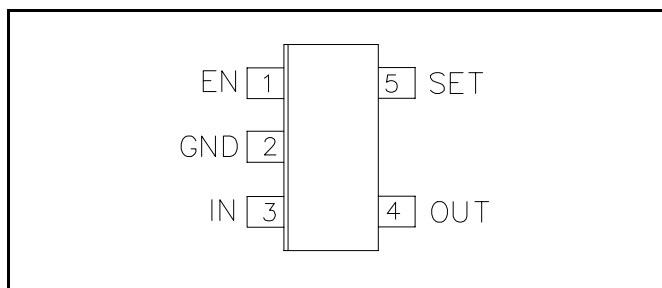

## ORDERING INFORMATION

Part Number	Package
SC8863-XXXCSK <sup>(1)(2)</sup>	SOT-23-5

Notes:

(1) Where -XXX denotes voltage options. Available voltages are: 2.50V (-250), 2.80V (-280), 3.00V (-300), and 3.30 (-330)V.

(2) Add suffix 'TR' for tape and reel.

## ABSOLUTE MAXIMUM RATINGS

Parameter	Symbol	Maximum	Units
Input Supply Voltage	V <sub>IN</sub>	-0.6 to +7	V
Power Dissipation T <sub>A</sub> = 70°C	P <sub>D</sub>	571	mW
Thermal Resistance	$\theta_{JA}$	256	°C/W
	$\theta_{JC}$	81	°C/W
Operating Ambient Temperature Range	T <sub>A</sub>	-40 to +85	°C
Operating Junction Temperature Range	T <sub>J</sub>	-40 to +150	°C
Storage Temperature Range	T <sub>STG</sub>	-65 to +150	°C
Lead Temperature (Soldering) 10 Sec	T <sub>LEAD</sub>	+300	°C
ESD Rating	ESD	1.25	kV

March 1, 2000

**PIN DESCRIPTIONS**

Pin #	Pin Name	Description
1	EN	Active high enable pin. Connect to VIN if not being used.
2	GND	Ground pin. Can be used for heatsinking if needed.
3	IN	Input pin.
4	OUT	Regulator output, sourcing up to 150mA
5	SET	Connecting this pin to ground results in the internally preset value for $V_{OUT}$ . Connecting to an external resistor divider changes $V_{OUT}$ to:  $V_{OUT} = 1.250 \cdot \left(1 + \frac{R1}{R2}\right)$

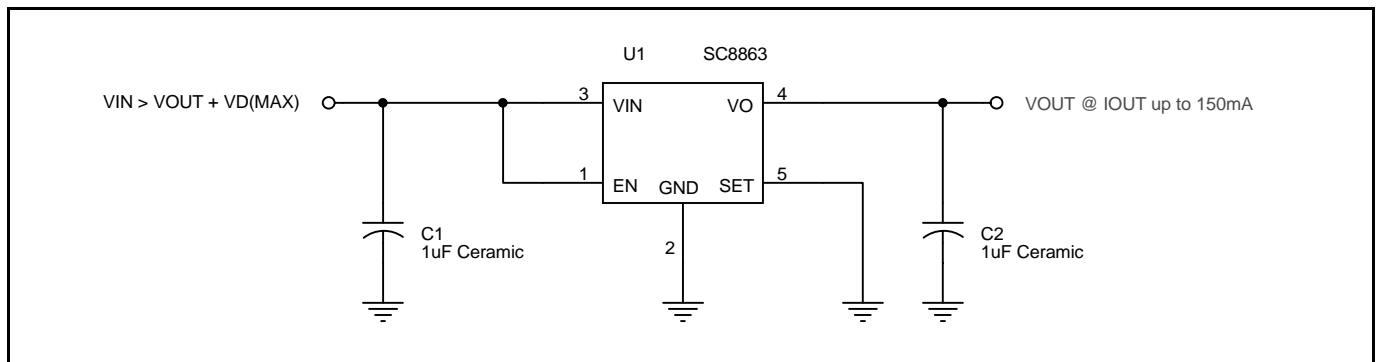
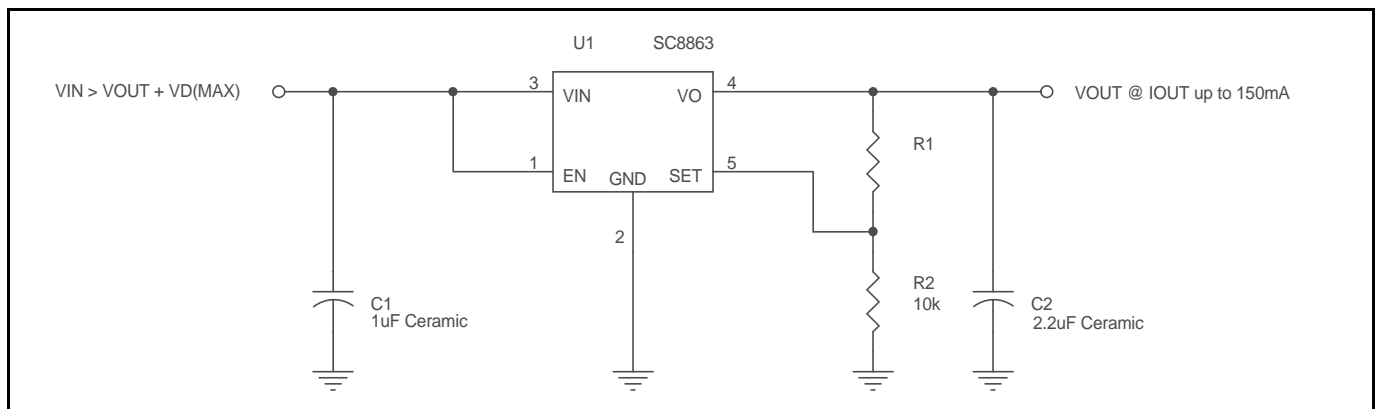
**TYPICAL APPLICATION - INTERNALLY PRESET OUTPUT VOLTAGE**

**TYPICAL APPLICATION - EXTERNALLY SET OUTPUT VOLTAGE<sup>(1)</sup>**

**NOTES:**

(1) Select R1 and R2 such that the current flowing through them is  $\geq 10\mu A$  (i.e.  $R2 \leq 120k\Omega$ ). A value of  $10k\Omega$  is recommended for R2. Please see Component Selection - Externally Set Output.

March 1, 2000

**ELECTRICAL CHARACTERISTICS**

 Unless specified:  $V_{IN} = 3.6V$ ,  $V_{SET} = GND$ ,  $V_{EN} = V_{IN}$ ,  $T_A = 25^\circ C$ . Values in **bold** apply over full operating ambient temperature range.

Parameter	Symbol	Conditions	Min	Typ	Max	Units
<b>IN</b>						
Supply Voltage Range	$V_{IN}$		<b>2.5</b>		<b>5.5</b>	V
Supply Current	$I_Q$	$I_{OUT} = 0mA$		100	130	$\mu A$
					<b>160</b>	
		$50mA \leq I_{OUT} \leq 150mA$		110	160	$\mu A$
					<b>200</b>	
$V_{EN} = 0V$		0.0001	1	$\mu A$		
			<b>2</b>			
<b>OUT</b>						
Output Voltage <sup>(1)</sup>	$V_{OUT}$	$I_{OUT} = 1mA$	-2.0%	$V_{OUT}$	+2.0%	V
		$1mA \leq I_{OUT} \leq 150mA, V_{OUT} + 1V \leq V_{IN} \leq 5.5V$	<b>-3.5%</b>		<b>+3.5%</b>	
Line Regulation <sup>(1)</sup>	$REG_{(LINE)}$	$2.5V \leq V_{IN} \leq 5.5V, SET = OUT, I_{OUT} = 1mA$		5	10	mV
					<b>12</b>	
Load Regulation <sup>(1)</sup>	$REG_{(LOAD)}$	$I_{OUT} = 0mA \text{ to } 50mA$		-10	-15	mV
					<b>-20</b>	
		$I_{OUT} = 0mA \text{ to } 100mA$		-15	-20	mV
					<b>-25</b>	
$I_{OUT} = 0mA \text{ to } 50mA, SET = OUT$		-2.5	-7.5	mV		
			<b>-15.0</b>			
$I_{OUT} = 0mA \text{ to } 100mA, SET = OUT$		-5	-15	mV		
			<b>-30</b>			
Dropout Voltage <sup>(1)(2)</sup>	$V_D$	$I_{OUT} = 1mA$		1.1		mV
		$I_{OUT} = 50mA$		55	90	mV
					<b>120</b>	
$I_{OUT} = 100mA$				110	180	mV
					<b>240</b>	
Current Limit	$I_{LIM}$		<b>150</b>	240	<b>350</b>	mA
Output Voltage Noise	$e_n$	$10Hz \text{ to } 99kHz, I_{OUT} = 50mA, C_{OUT} = 1\mu F$		90		$\mu V_{RMS}$
					75	
Power Supply Rejection Ratio	PSRR	$f \leq 1kHz$		55		dB

March 1, 2000

**ELECTRICAL CHARACTERISTICS (Cont.)**

 Unless specified:  $V_{IN} = 3.6V$ ,  $V_{SET} = GND$ ,  $V_{EN} = V_{IN}$ ,  $T_A = 25^{\circ}C$ . Values in **bold** apply over full operating ambient temperature range.

Parameter	Symbol	Conditions	Min	Typ	Max	Units
<b>EN</b>						
EN Input Threshold	$V_{IH}$		<b>1.8</b>			V
	$V_{IL}$				<b>0.4</b>	
EN Input Bias Current <sup>(3)</sup>	$I_{EN}$	EN = $V_{IN}$		0	100	nA
					<b>200</b>	
<b>SET</b>						
Sense/Select Threshold	$V_{TH}$		<b>20</b>	55	<b>80</b>	mV
SET Reference Voltage <sup>(1)</sup>	$V_{SET}$	$I_{OUT} = 1mA$	1.225	1.250	1.275	V
		$1mA \leq I_{OUT} \leq 150mA, 2.5V \leq V_{IN} \leq 5.5V$	<b>1.206</b>		<b>1.294</b>	
SET Input Leakage Current <sup>(3)</sup>	$I_{SET}$	SET = 1.3V		0.015	2.500	nA
					<b>5.000</b>	
<b>OVER TEMPERATURE PROTECTION</b>						
High Trip Level	$T_{HI}$			170		$^{\circ}C$
Hysteresis	$T_{HYST}$			10		$^{\circ}C$

**NOTE:**

(1) Low duty cycle pulse resting with Kelvin corrections required.

(2) Defined as the input to output differential at which the output voltage drops 100mV below the value measured at a differential of 2V.

(3) Guaranteed by design.

March 1, 2000

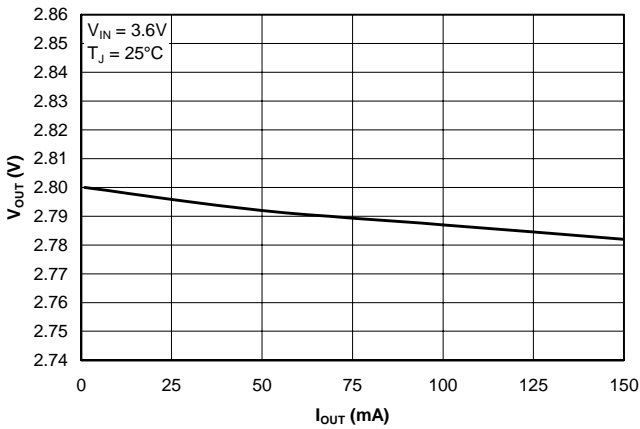
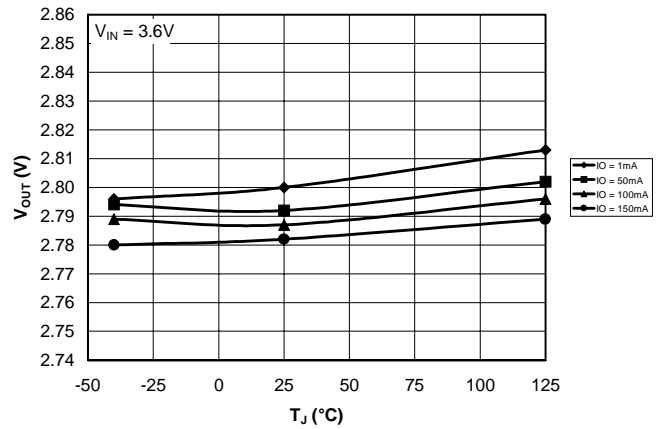
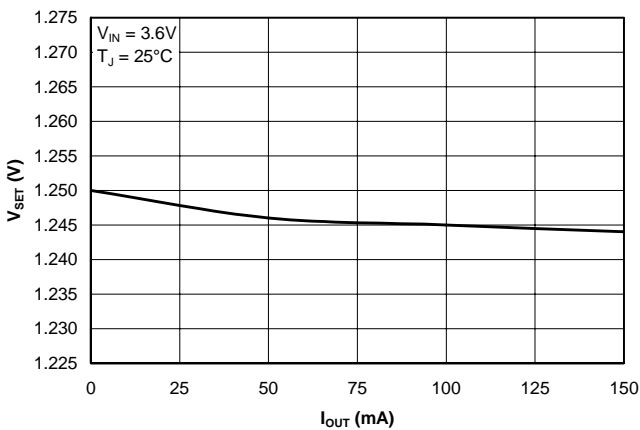
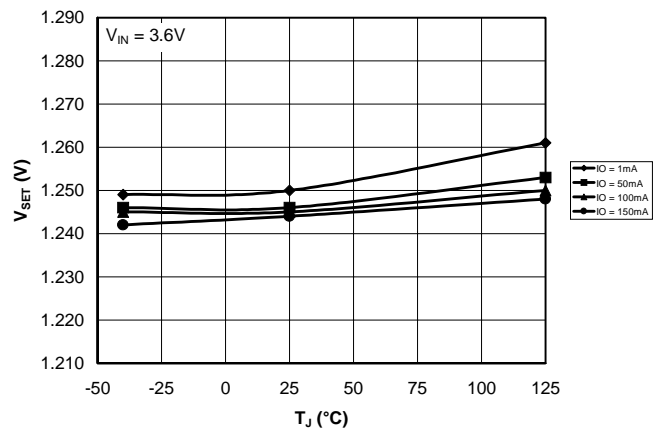
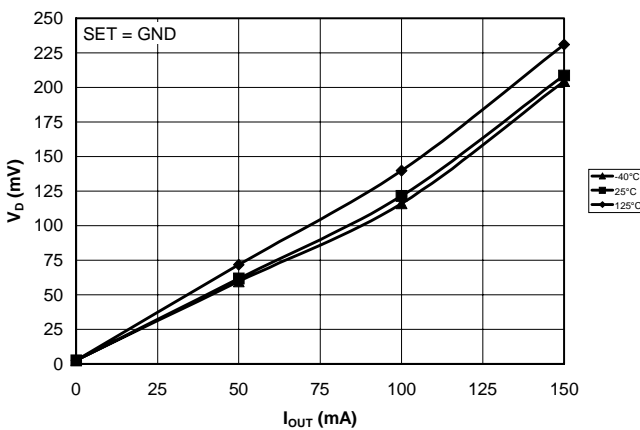
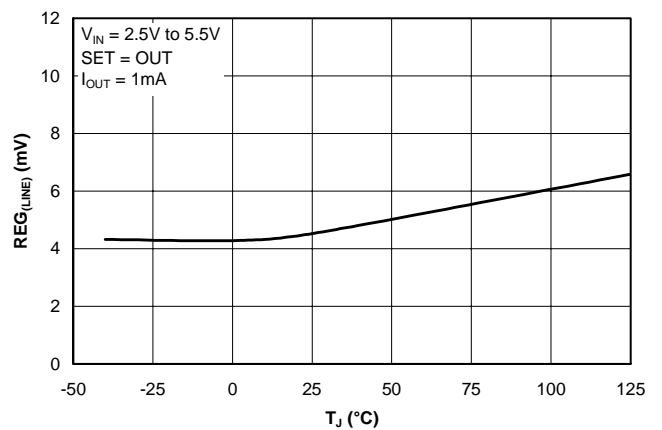
**TYPICAL CHARACTERISTICS**
**Output Voltage vs. Output Current**

**Output Voltage vs. Junction Temperature vs. Output Current**

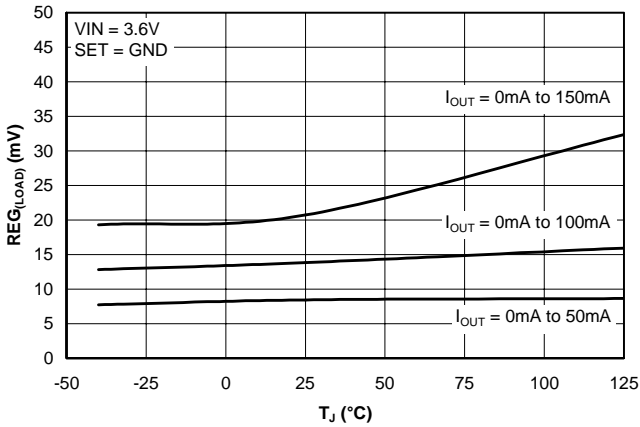
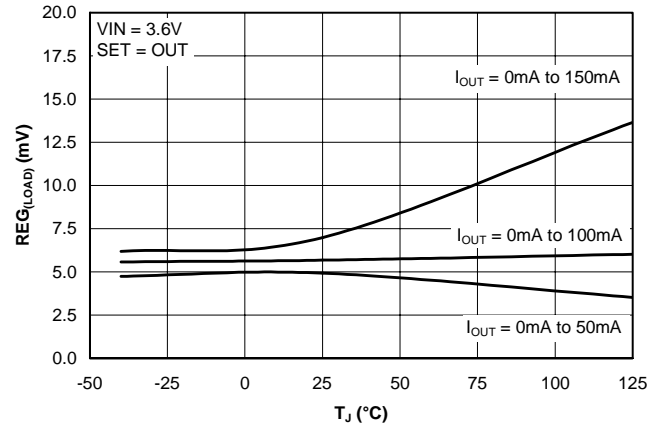
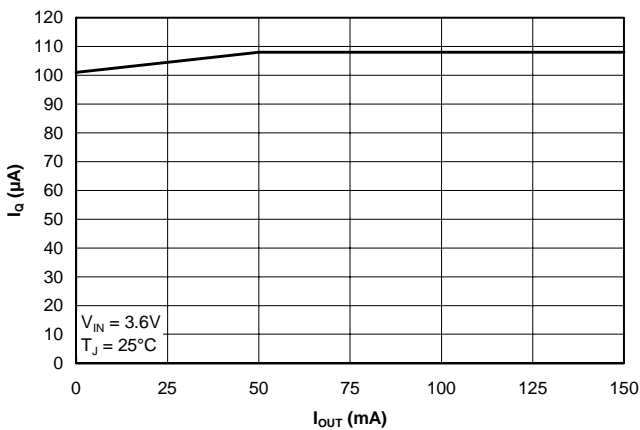
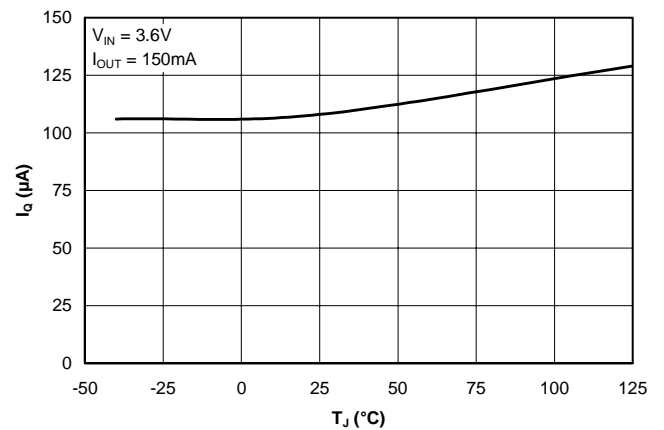
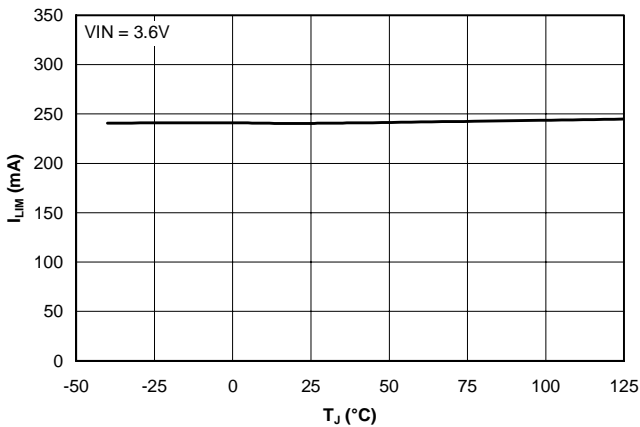
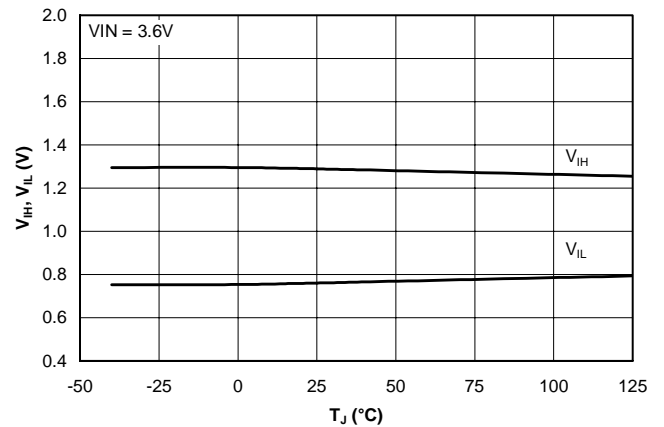
**SET Reference Voltage vs. Output Current**

**SET Reference Voltage vs. Junction Temperature vs. Output Current**

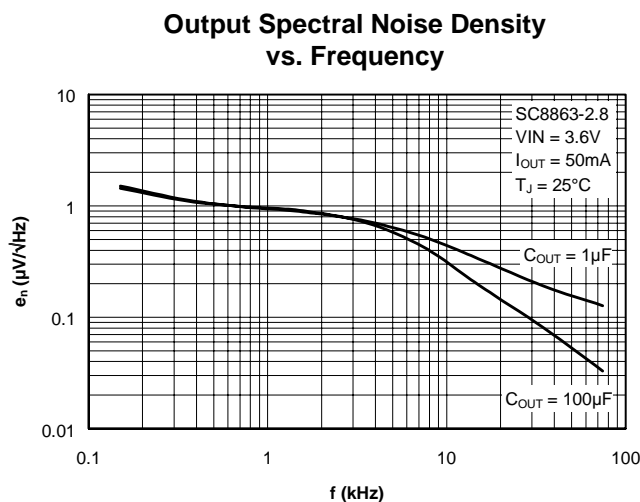
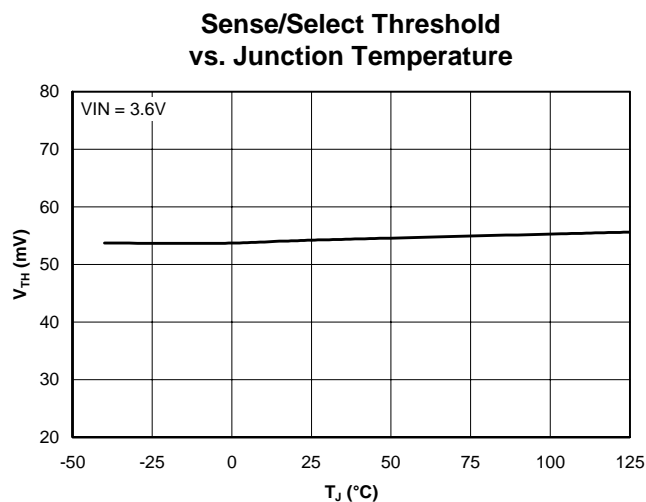
**Dropout Voltage vs. Output Current vs. Junction Temperature**

**Line Regulation vs. Junction Temperature**

March 1, 2000

**TYPICAL CHARACTERISTICS (Cont.)**
**Load Regulation (SET = GND)  
 vs. Junction Temperature**

**Load Regulation (SET = OUT)  
 vs. Junction Temperature**

**Supply Current  
 vs. Output Current**

**Supply Current vs.  
 Junction Temperature**

**Current Limit vs.  
 Junction Temperature**

**Enable Input Threshold vs.  
 Junction Temperature**

March 1, 2000

**TYPICAL CHARACTERISTICS (Cont.)**

**APPLICATIONS INFORMATION**
**Theory Of Operation**

The SC8863 is intended for applications where very low dropout voltage, low supply current and low output noise are critical. It provides a very simple, low cost solution that uses very little pcb real estate. Fixed output voltage options require the use of only two external capacitors for operation.

Each voltage option has both fixed and adjustable output voltage modes. Grounding the SET pin (pulling it below the Sense/Select threshold of 55mV) will connect the internal resistor divider to the error amplifier resulting with the internally preset output voltage. If SET is pulled above this threshold, then the Sense/Select switch will connect the SET pin to the error amplifier. The output will be regulated such that the voltage at SET will equal V<sub>SET</sub>, the SET reference voltage (typically 1.250V).

An active high enable pin (EN) is provided to allow the customer to shut down the part and enter an extremely low power Off-state. A logic Low signal will reduce the supply current to 0.1nA.

**Component Selection - General**

Output capacitor - Semtech recommends a minimum capacitance of 1µF at the output with an equivalent series resistance (ESR) of <1Ω over temperature. Ceramic capacitors are ideal for this application. Increas-

ing the bulk capacitance will further reduce output noise and improve the overall transient response.

Input capacitor - Semtech recommends the use of a 1µF ceramic capacitor at the input. This allows for the device being some distance from any bulk capacitance on the rail. Additionally, input droop due to load transients is reduced, improving load transient response.

**Component Selection - Externally Set Output**

Please refer to Figure 1 below. The output voltage can be externally adjusted anywhere within the range from 1.25V to (VIN<sub>(MIN)</sub> - VD<sub>(MAX)</sub>). The output voltage will be in accordance with the following equation:

$$VO = 1.250 \cdot \left(1 + \frac{R1}{R2}\right)$$

1% tolerance resistors are recommended. The values of R1 and R2 should be selected such that the current flow through them is ≥ 10µA (thus R2 ≤ 120kΩ).

At high input voltages and/or high output currents, sta-

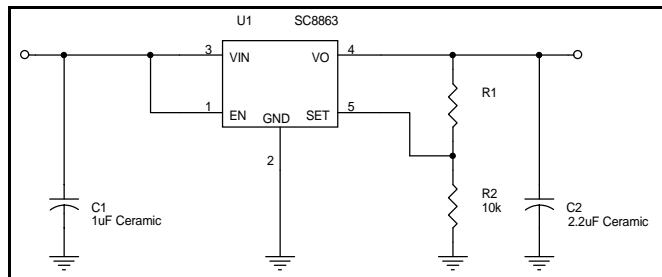

Figure 1: Externally set output

March 1, 2000

bility may be improved by increasing C2 to 2.2 $\mu$ F and reducing R2 to 10k $\Omega$ . See "Component Selection - General" for input capacitor requirements.

### Thermal Considerations

The worst-case power dissipation for this part is given by:

$$P_{D(MAX)} = (VIN_{(MAX)} - VO_{(MIN)}) \cdot IO_{(MAX)} + VIN_{(MAX)} \cdot IQ_{(MAX)}$$

For all practical purposes, it can be reduced to:

$$P_{D(MAX)} = (VIN_{(MAX)} - VO_{(MIN)}) \cdot IO_{(MAX)}$$

Looking at a typical application:

$$VIN_{(MAX)} = 4.2V$$

$$VO = 3V - 3.5\% \text{ worst-case}$$

$$IO = 150mA$$

$$TA = 85^{\circ}C$$

$$P_{D(MAX)} = (4.2 - 2.895) \cdot 0.150 = 196 \text{ mW}$$

Using this figure, we can calculate the maximum thermal impedance allowable to maintain  $T_J \leq 150^{\circ}C$ :

$$\theta_{(J-A)(MAX)} = \frac{(T_{J(MAX)} - T_{A(MAX)})}{P_{D(MAX)}} = \frac{(150 - 85)}{0.196} = 332^{\circ}C/W$$

With the standard SOT-23-5 Land Pattern shown at the end of this datasheet, and minimum trace widths, the thermal impedance junction to ambient for SC8863 is 256 $^{\circ}C/W$ . Thus with no additional heatsinking,  $T_{J(MAX)} = 135^{\circ}C$ .

The junction temperature can be further reduced by the use of larger trace widths, and connecting pcb copper area to the GND pin (pin 2), which connects directly to the device substrate. Adding approximately one square inch of pcb copper to pin 2 will reduce  $\theta_{TH(J-A)}$  to approximately 130 $^{\circ}C/W$  and  $T_{J(MAX)}$  to approximately 110 $^{\circ}C$ , for example. Lower junction temperatures improve overall output voltage accuracy. A sample pcb layout for the Internally Preset Output Voltage circuit on page 2 is shown in Figure 2 below.

### Layout Considerations

While layout for linear devices is generally not as critical as for a switching application, careful attention to detail will ensure reliable operation. See Figure 2 below for a sample layout.

1) Attaching the part to a larger copper footprint will enable better heat transfer from the device, especially on PCBs where there are internal ground and power planes.

2) Place the input and output capacitors (and the capacitor from OUT to SET for adjustable applications) close to the device for optimal transient response and device behaviour.

3) Connect all ground connections directly to the ground plane. If there is no ground plane, connect to a common local ground point before connecting to board ground.

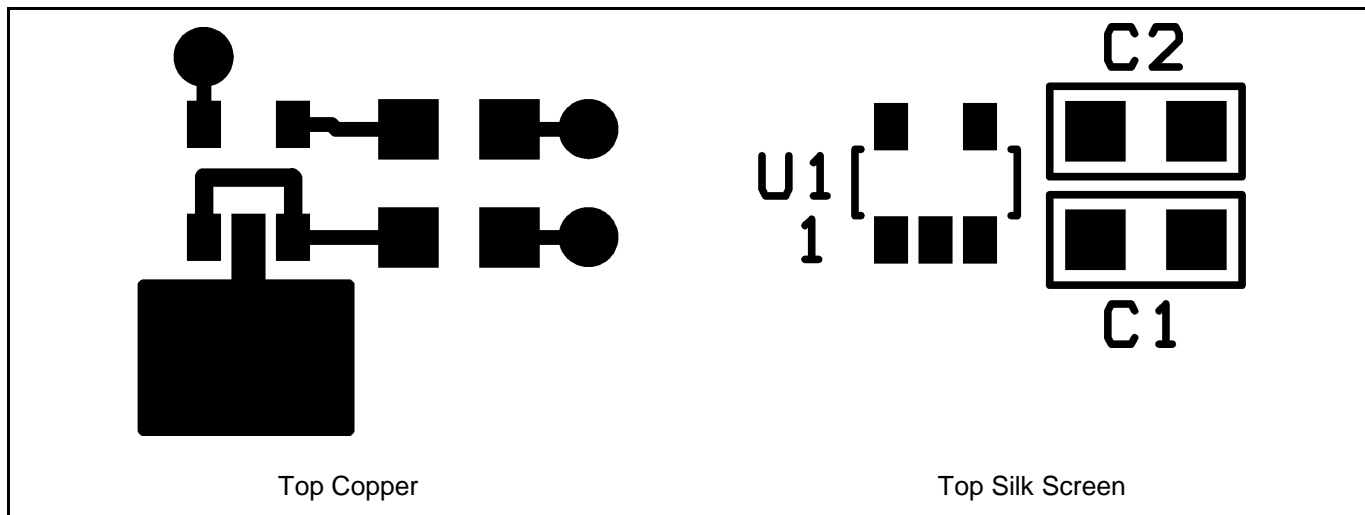

Figure 2: Suggested pcb layout based upon internally preset output voltage application on page 2.

#### NOTES:

- (1) All vias go to the ground plane.
- (2) Copper area on pin 2 is recommended, but not required. Connect to the ground plane with a via or vias.

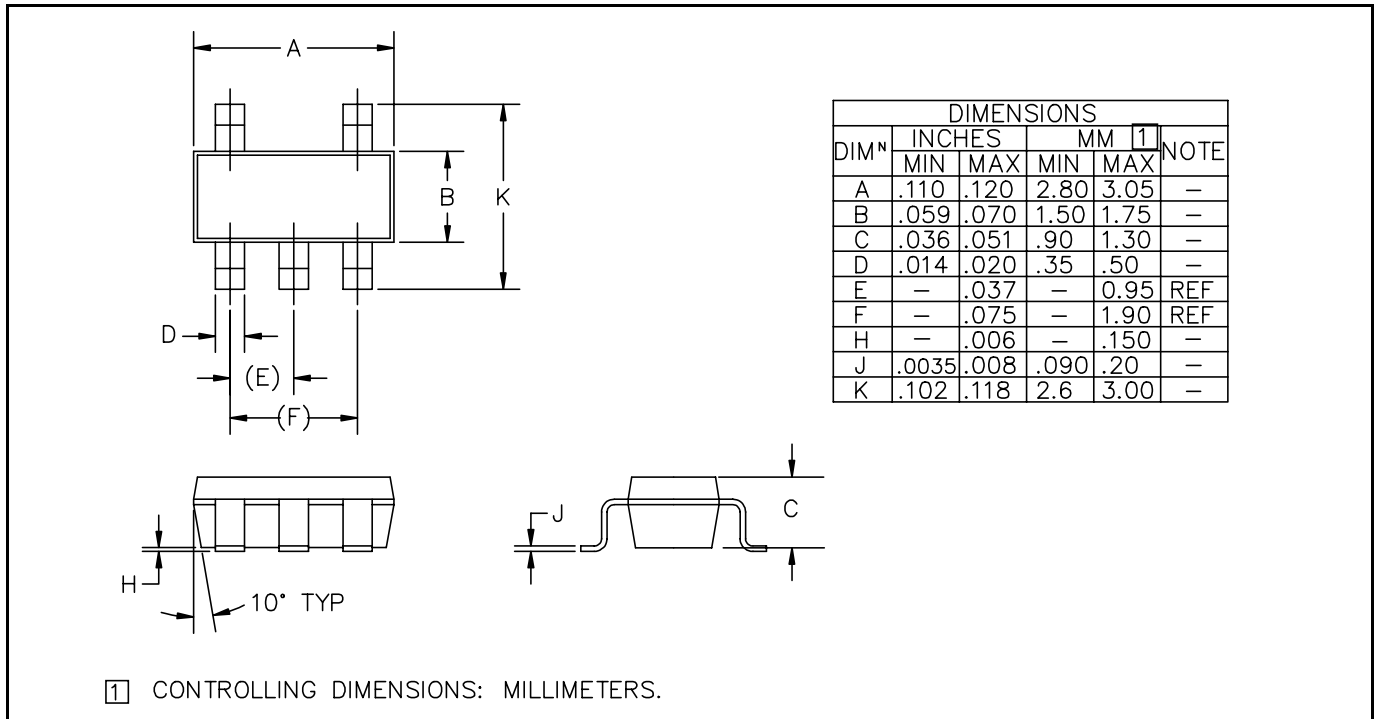
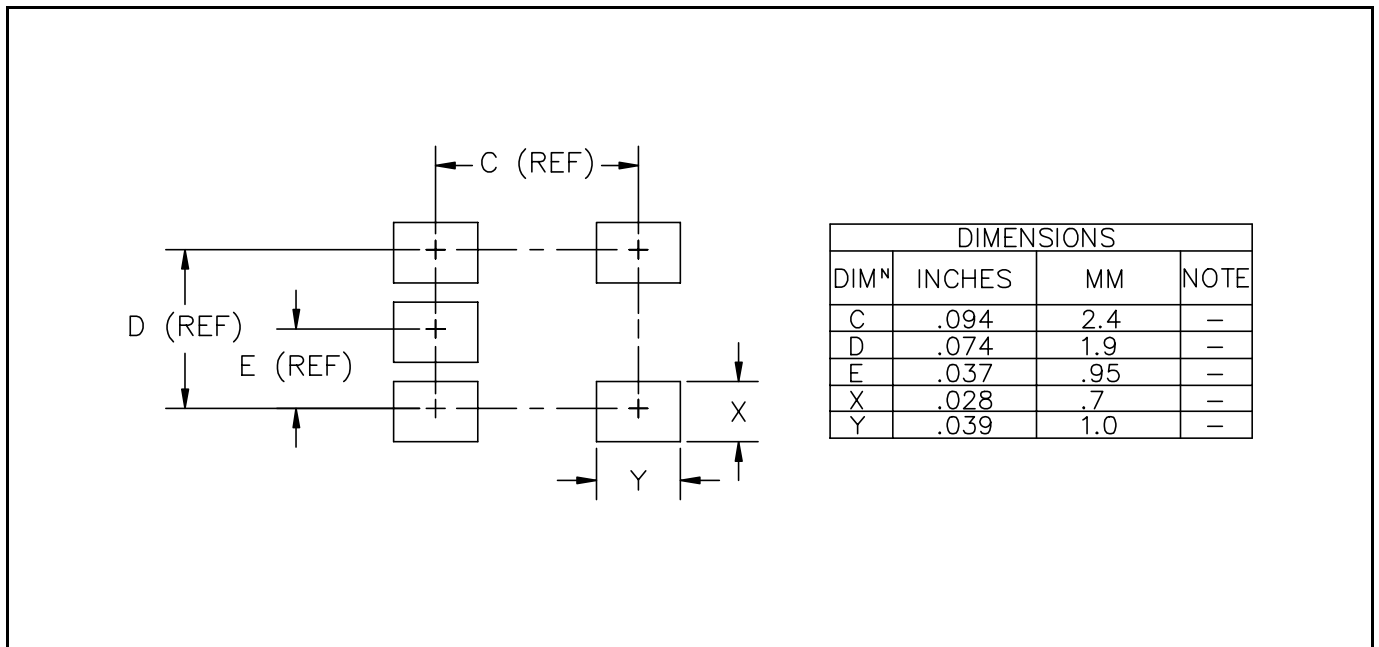

March 1, 2000

**DEVICE OUTLINE - SOT23-5**

**LAND PATTERN - SOT23-5**

ECN 00-915