

2-MEMORY T/P DIALER WITH REDIAL & HANDFREE, HOLD FUNCTION

DESCRIPTION

The SC9302 series tone/pulse dialers are CMOS LSIs for the telecommunication system. They are designed to meet various dialing specifications through resistor options matrix.

The SC9302 series tone/pulse dialers are offered in four different versions. They are SC9302X normal version, SC9302F/G/H simple version, SC9302XT key-tone version and SC9302XLT key-tone/lock functions version. The SC9302X normal version provides the pin-selected lock function; the SC9302XT version provides the key-tone function; the SC9302XLT version provides both the key-tone function and key board-operated IDD lock function. All of the above three versions also supply the following functions: Hold-line, Hand-free and LCD dialing number display interface, all of which are suitable for feature phone applications. However, the SC9302F/G/H version is simpler than the other three versions. It provides only a redialing memory for a simple low-cost system application.

FEATURES

- * Universal specification
- * Operating voltage: 2.0V~5.5V
- * Low stand-by current
- * Low memory retention current:0.1 μ A(Typ.)
- * Tone/pulse switchable
- * Interface with LCD driver
- * 32 digits for redialing
- * 32 digits for the SA memory dialing
- * One-key redialing
- * Pause and P→T key for PBX
- * 4x4 keyboard matrix
- * 3.58MHz crystal or ceramic resonator

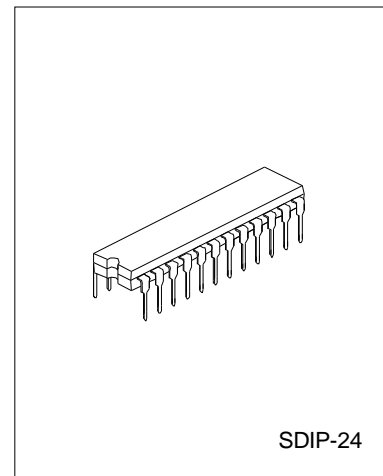

SC9302D Package

- * Hand-free control
- * Hold-line control
- * Pause, P→T can be saved for redialing
- * Lock function
- * Key tone function
- * Resistor options:
 - M/B ratio
 - Flash function and flash time
 - Pause and P→T duration
 - Pulse number
 - Keyboard operated IDD lock function

ORDERING INFORMATION

Function Item	Keytone	Lock Function		Hold-line	Hand-free	LCD Interface	Memory No.	Package
		Pin Selection	Keyboard Operated					
SC9302X (Normal version)								
SC9302A	--	√	--	--	--	--	2	DIP-18
SC9302B	--	√	--	√	√	--	2	SDIP-22
SC9302C	--	√	--	--	--	√	2	DIP-20
SC9302D	--	√	--	√	√	√	2	SDIP-24
SC9302XT (Key-tone version)								
SC9302AT	√	--	--	--	--	--	2	DIP-18
SC9302BT	√	--	--	√	√	--	2	SDIP-22
SC9302CT	√	--	--	--	--	√	2	DIP-20
SC9302DT	√	--	--	√	√	√	2	SDIP-24
SC9302XLT (Key-tone/Lock function version)								
SC9302ALT	√	--	√	--	--	--	2	DIP-18
SC9302BLT	√	--	√	√	√	--	2	SDIP-22
SC9302CLT	√	--	√	--	--	√	2	DIP-20
SC9302DLT	√	--	√	√	√	√	2	SDIP-24
SC9302F/G/H (Simple version)								
SC9302F	--	--	--	--	--	--	1	DIP-18
SC9302G	--	--	--	--	--	--	1	DIP-16
SC9302H	--	--	--	--	--	--	1	DIP-18

BLOCK DIAGRAM

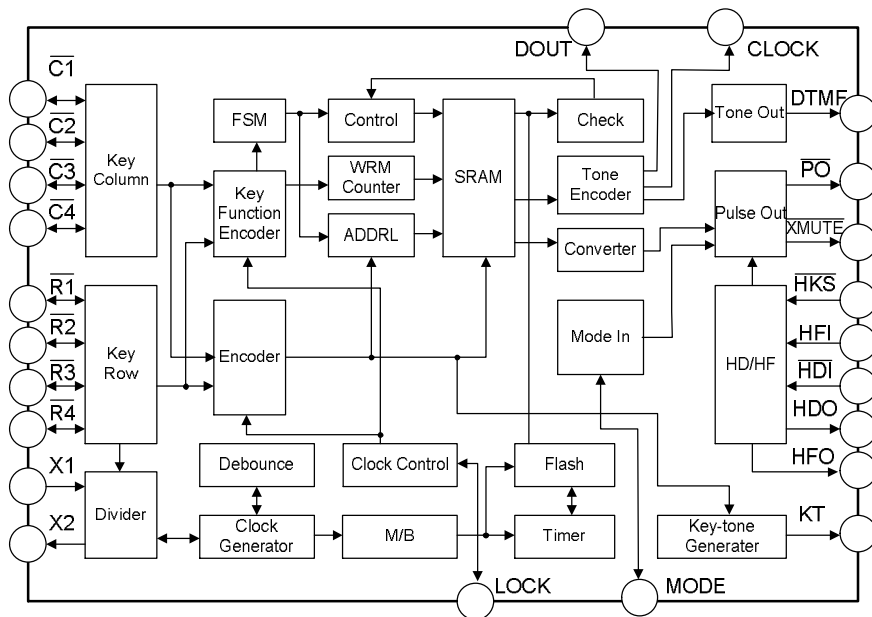

KEYBOARD INFORMATION

SC9302X and SC9302XT

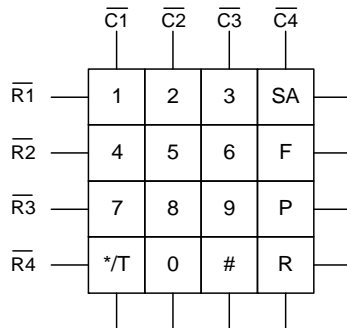

SC9302XLT

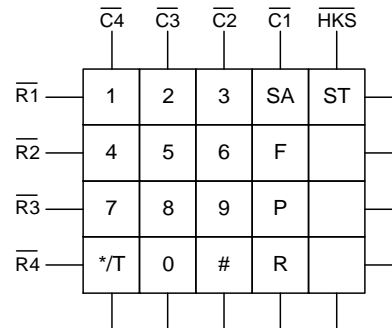

SC9302F

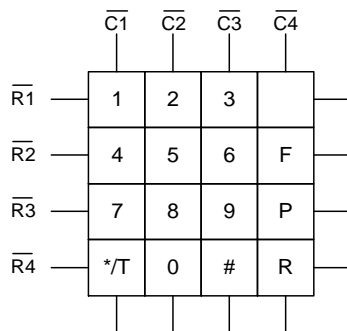

SC9302H

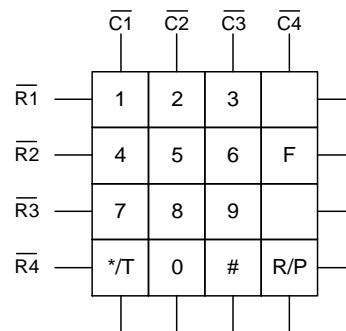

SC9302G

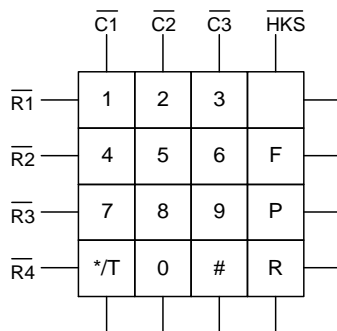

ABSOLUTE MAXIMUM RATINGS (T_{amb}=25°C, f_{osc}=3.5795MHz, unless otherwise specified)

Characteristics	Symbol	Value	Unit
Supply Voltage	V _{DD}	-0.3 ~ 5.5	V
Input Voltage	V _{IN}	V _{SS} -0.3V ~ V _{CC} +0.3V	V
Operating Temperature	T _{opr}	-20 ~ +75	°C
Storage Temperature	T _{stg}	-50 ~ +125	°C

ELECTRICAL CHARACTERISTICS ($T_{amb}=25^{\circ}C$, $f_{osc}=3.5795MHz$, unless otherwise specified)

Characteristics	Symbol	Test Conditions		Min.	Typ.	Max.	Unit	
		VDD	Condition					
Operating Voltage	VDD	--	--	2	--	5.5	V	
Operating Current	IDD	2.5V	Pulse	Off-hook	--	0.2	1	mA
			Tone	Keypad entry No load	--	0.6	2	mA
Stand-by Current	ISTB	1V	On-hook, no load, No entry	--	--	1	μA	
Memory Retention Voltage	VR	--	--	1	--	5.5	V	
Memory Retention Current	IR	1V	On-hook	--	0.1	0.2	μA	
Input Low Voltage	VIL	--	--	Vss	--	0.2 VDD	V	
Input High Voltage	VIH	--	--	0.8 VDD	--	VDD	V	
\overline{XMUTE} Leakage current	IXMO	--	$V_{\overline{XMUTE}}=12V$, No entry	--	--	1	μA	
\overline{XMUTE} Sink Current	IOLXM	2.5V	$V_{\overline{XMUTE}}=0.5V$	1	--	--	mA	
\overline{HKS} Pin Input Current	$I_{\overline{HKS}}$	2.5V	$V_{\overline{HKS}}=2.5V$	--	--	0.1	μA	
HFI Pull-Low Resistance	RHFI	2.5V	$V_{HFI}=2.5V$	--	200	--	k Ω	
\overline{HDI} Pull-High Resistance	$R_{\overline{HDI}}$	2.5V	$V_{\overline{HDI}}=0V$	--	200	--	k Ω	
Keypad Pin Source Current	IOH1	2.5V	$V_{OH}=0V$	-4	--	-40	μA	
Keypad Pin Sink Current	IOL1	2.5V	$V_{OL}=2.5V$	200	400	--	μA	
HFO Pin Source Current	IOH2	2.5V	$V_{OH}=2V$	-1	--	--	mA	
HFO Pin Sink Current	IOL2	2.5V	$V_{OL}=0.5V$	1	--	--	mA	
HDO Pin Source Current	IOH3	2.5V	$V_{OH}=2V$	-1	--	--	mA	
HDO Pin Sink Current	IOL3	2.5V	$V_{OL}=0.5V$	1	--	--	mA	
Pause Time After Flash	tFP	--	Control key	--	0.2	--	s	
			Digit key	--	1	--		
One-key Redialing Pause Time	tRP	--	One-key redialing	--	1	--	s	
Key-in Debounce Time	tDB	--	--	--	20	--	ms	
Break Time for One-key Redialing	tBRK	--	One-key redialing	--	1.2	--	s	
Key-tone Duration	tKT	--	--	34	--	--	ms	
Key-tone Frequency	tKTC	--	--	1.2	--	--	KHz	
System Frequency	fosc	--	Crystal =3.5795MHz	3.5759	3.5795	3.5831	MHz	

PULSE MODE ELECTRICAL CHARACTERISTICS (T_{amb}=25°C, f_{osc}=3.5795MHz, unless otherwise specified)

Characteristics	Symbol	Test Conditions		Min.	Typ.	Max.	Unit
		VDD	Condition				
\overline{PO} Output Source Current	IPOH	2.5V	VOH =2V	-0.2	--	--	mA
\overline{PO} Output Sink Current	IPOL	2.5V	VOL =0.5V	0.2	0.6	--	mA
Pulse Rate	PR	--	MODE pin is connected to VDD	--	10	--	pps
			MODE pin is opened.	--	20	--	
Make/Break Ratio	M/B	--	A resistor is linked between $\overline{R2}$ and $\overline{C1}$.	--	33:66	--	%
			No resistor is linked between $\overline{R2}$ and $\overline{C1}$.	--	40:60	--	
Pre-digit-pause Time	TPDP	--	M/B ratio =40:60	--	40(10pps) 20(20pps)	--	ms
			M/B ratio =33:66	--	33(10pps) 17(20pps)	--	
Inter-digit-pause Time	TIDP	--	Pulse rate =10pps	--	800	--	ms
			Pulse rate =20pps	--	500	--	
Pulse Make Duration	TM	--	A resistor is linked between $\overline{R2}$ and $\overline{C1}$.	--	33(10pps) 17(20pps)	--	ms
			No resistor is linked between $\overline{R2}$ and $\overline{C1}$.	--	40(10pps) 20(20pps)	--	
Pulse Break Duration	TB	--	A resistor is linked between $\overline{R2}$ and $\overline{C1}$.	--	66(10pps) 33(20pps)	--	ms
			No resistor is linked between $\overline{R2}$ and $\overline{C1}$.	--	60(10pps) 30(20pps)	--	

-tone MODE ELECTRICAL CHARACTERISTICS (T_{amb}=25°C, f_{osc}=3.5795MHz, unless otherwise specified)

Characteristics	Symbol	Test Conditions		Min.	Typ.	Max.	Unit	
		VDD	Condition					
DTMF Output DC Level	VTDC	--	--	0.45V _{DD}	--	0.7V _{DD}	V	
DTMF Sink Current	ITOL	2.5V	VDTMF =0.5V	0.1	--	--	mA	
DTMF Output AC Level	VTAC	--	Row group, RL =5kΩ	0.12	0.155	0.18	V _{rms}	
DTMF Output Load	RL	2.5V	THD ≤ -23dB	5	--	--	kΩ	
Column Pre-emphasis	ACR	2.5V	Row group = 0dB	1	2	3	dB	
Tone Signal Distortion	THD	2.5V	RL =5kΩ	--	-30	-23	dB	
Minimum Tone Duration	t _{MIN}	--	Auto-redial	Others	--	82.5	--	ms
				9302G	--	100	--	
Minimum Inter-tone Pause	t _{ITPM}	--	Auto-redial	Others	--	85.5	--	ms
				9302G	--	106	--	

$$THD \text{ (Distortion)}(dB)=20\log\left(\frac{\sqrt{V_1^2 + V_2^2 + \dots + V_n^2}}{\sqrt{V_i^2 + V_h^2}}\right)$$

V_i, V_h: Row group and column group signals; V₁, V₂, ...V_n: Harmonic signals (BW=300Hz~3500Hz)

PIN CONFIGURATIONS

SC9302X NORMAL VERSION

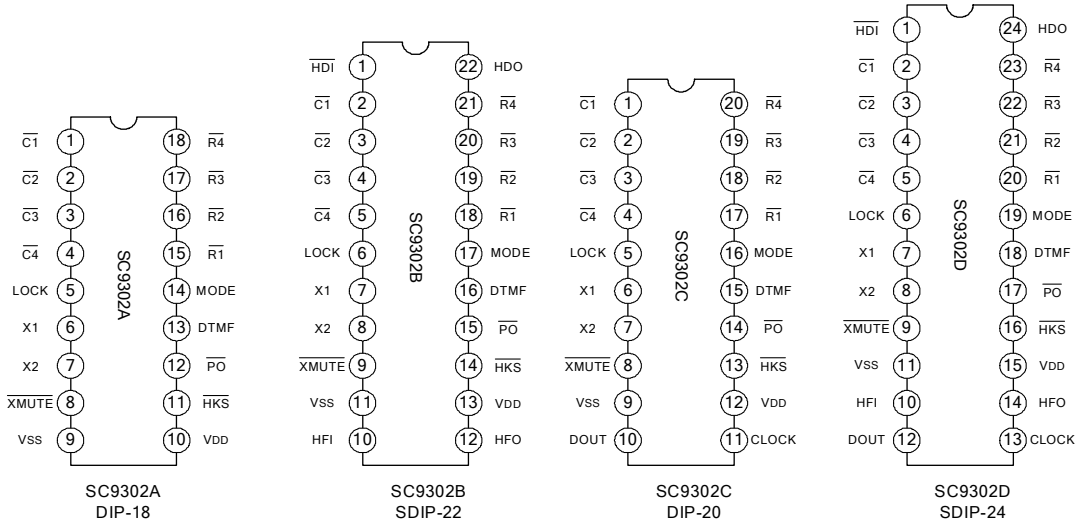

SC9302XT/XLT VERSION

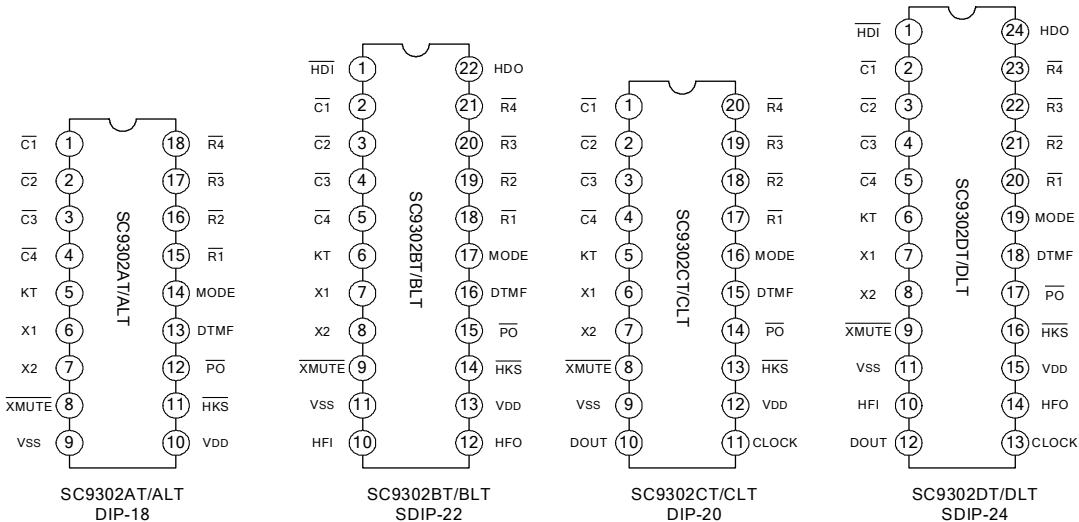

SC9302F/G/H SIMPLE VERSION

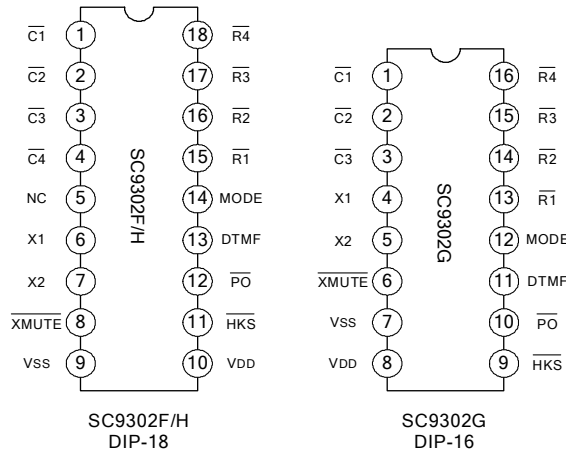

PIN DESCRIPTION

Pin Name	Description
$\overline{C1} \sim \overline{C4}$ $\overline{R1} \sim \overline{R4}$	<p>These pins construct a 4x4 keyboard matrix to perform the keyboard input detecting and dialing specification setting functions, when on-hook ($\overline{HKS} = \text{high}$) all the pins are set to high. While off-hook the column group ($\overline{C1} \sim \overline{C4}$) stays low and the row group ($\overline{R1} \sim \overline{R4}$) is set to high for key input detecting.</p> <p>An inexpensive single contact 4x4 keyboard can be an input device. Pressing a key connects a single column to a single row, and actuates the system oscillator to result in a dialing signal output. If more than two keys are pressed at the same time, no response can be brought about. The key-in debounce time is 20ms. Refer to the keyboard table for keyboard arrangement and to the functional description for dialing specification selection.</p>
X1	<p>The system oscillator consists of an inverter, a bias resistor and the necessary load capacitor on chip. Connecting a standard 3.579545MHz crystal or ceramic resonator to X1 and X2 terminals can implement the oscillator function. The oscillator is turned off in the stand-by mode, and is actuated whenever a keyboard entry is detected.</p>
X2	
\overline{XMUTE}	<p>The \overline{XMUTE} is an NMOS open drain structure pulled to VSS during dialing signal transmitting. Otherwise, it is an open circuit. The \overline{XMUTE} is used to mute the speech circuit when transmitting the dial signal.</p>
\overline{HKS}	<p>This pin is used to monitor the status of the hook-switch and its combination with HFI/\overline{HDI} can control the \overline{PO} pin output to make or break the line.</p> <p>$\overline{HKS} = VDD$: On-hook state ($\overline{PO} = \text{low}$). Except HFI/$\overline{HDI}$ (hand-free / hold-line control input), other functions are all disabled.</p> <p>$\overline{HKS} = VSS$: Off-hook state ($\overline{PO} = \text{high}$). The chip is in the stand-by mode and ready to receive the key input.</p>
\overline{PO}	<p>This pin is a CMOS output structure, it receives \overline{HKS} and HFO/HDO signals to control the dialer so as to connect or disconnect the telephone line.</p> <p>\overline{PO} outputs low to break line when \overline{HKS} is high (on-hook) and HFO/HDO is low. \overline{PO} outputs high to make line when \overline{HKS} is low (off-hook) or HFO is high or HDO is high.</p> <p>During the off-hook state, the pin also outputs the dialing pulse train in pulse mode dialing. While in the tone mode, this pin is always high.</p>
MODE	<p>This is a three-state input/output pin, provided to the user for selecting a dialing mode among Tone/20pps/10pps.</p> <p>MODE=VDD: Pulse mode, 10pps.</p> <p>MODE=OPEN: Pulse mode, 20pps.</p> <p>MODE=VSS: Tone mode.</p> <p>During the pulse mode dialing, switching this pin to the tone mode changes the following entrance of digits to the tone mode. When the chips are working in the tone mode, the switching from tone to the pulse mode will be recognized.</p>

(To be continued)

(Continued)

Pin Name	Description
DTMF	This pin is active only when the chip transmits tone dialing signals. Otherwise, it always outputs low. The pin outputs tone signals to drive the external transmitter amplifier circuit. The load resistor should not be less than 5kΩ.
$\overline{\text{HDI}}$	This pin is a schmitt trigger input structure. Active low. Applying a negative going pulse to this pin can toggle the HDO output once. An external RC network is recommended to use for the input debouncing. The pull-high resistance is 200kΩ typically.
HDO	The HDO is a CMOS output structure. Its output is toggle controlled by a negative transition on $\overline{\text{HDI}}$. When HDO is toggled to high, $\overline{\text{PO}}$ keeps high to hold the line. The hold function can be released by setting HFO high or by an on-off hook operation or by another $\overline{\text{HDI}}$ input. The HDO pin can directly drive the melody generator to produce hold-line background melody. Refer to the functional description for the hold-line function.
KT	Key-tone output pin. It outputs 1.2kHz tone carrier when any key is pressed in the pulse mode or when the function keys are pressed in the tone mode.
HFI	This pin is a schmitt trigger input structure. Active high. Applying a positive going pulse to HFI can toggle the HFO once and hence control the hand-free function. The pull-low resistance of HFI is 200KΩ typically. An external RC network is recommended to use for the input debouncing.
HFO	The HFO is a CMOS output structure. Its output is toggle controlled by a positive transition on HFI pin. When HFO is high, the hand-free function is enabled and $\overline{\text{PO}}$ outputs high to connect the line. The hand-free function can be released by setting HDO high or by an on-off-hook operation or by another HFI input. Refer to the functional description for the hand-free functional operation.
LOCK	This is a three-state input/output pin, provided to the user for controlling the long distance call function with a lock-switch. LOCK=OPEN: Normal dialing (no lock). LOCK=VDD: "0,9" is inhibited for use as the first key input. LOCK=VSS: "0" is inhibited for use as the first key input.
DOUT	This is an NMOS open drain output pin. It outputs the BCD code of the dialing digits to the LCD driver chip (SC16XX series) or μC for dialing number display. Refer to the functional description for the detailed timing.
CLOCK	NMOS open drain output. When dialing, it outputs a series of pulse train for the DOUT data synchronization. The DOUT data is valid at the falling edge of clock.
VDD	Positive power supply, 2.0V~5.5V for normal operation.
VSS	Negative power supply.

FUNCTION DESCRIPTION

1. KEYBOARD MATRIX

The $\overline{C1} \sim \overline{C4}$ and $\overline{R1} \sim \overline{R4}$ make up of a keyboard matrix. Together with a standard 4x4 keyboard, the keyboard matrix is used for dialing entrance. In addition, the keyboard matrix provides resistor option for different dialing specification selections. The keyboard arrangement for each of the SC9302 series are listed in KEYBOARD INFORMATION.

2. TONE FREQUENCY

Tone Name	Output Frequency (Hz)		%Error
	Specified	Actual	
$\overline{R1}$	697	699	+0.29%
$\overline{R2}$	770	766	-0.52%
$\overline{R3}$	852	847	-0.59%
$\overline{R4}$	941	948	+0.74%
$\overline{C1}$	1209	1215	+0.50%
$\overline{C2}$	1336	1332	-0.30%
$\overline{C3}$	1477	1472	-0.34%

% Error does not contain the crystal frequency drift.

3. DIALING SPECIFICATION SELECTION

By means of adding resistors across keyboard matrix pins, various dialing specifications can be selected. The allowable option resistor connections are shown right.

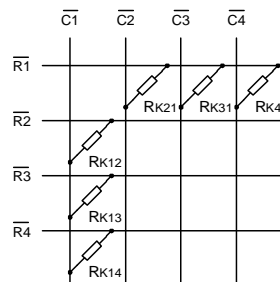

All the resistors are 330kΩ. The resistor option functions and the default specifications (without option resistors) are listed below.

Option Resistor	Option Function	Default (No Resistor)
RK12	Make/Break Ratio Selection	40:60
RK13	Flash Function And Flash Time Selection	Flash = control function Flash time = 600ms
RK14		
RK21	Pause & P→T Duration Selection	TP = 3.6s , TP→T = 3.6s
RK31	Pulse Number Selection Or IDD Lock Selection	N or Keyboard operated lock
RK41		

4. M/B RATIO SELECTION TABLE

RK13	M/B Ratio(%)
No	40:60
Yes	33.3:66.6

5. FLASH FUNCTION/TIME(DURATION) SELECTION TABLE

RK13	RK14	Flash Function	Flash Time (TF)
No	No	Control	600ms
No	Yes	Digit	600ms
Yes	No	Digit	98ms
Yes	Yes	Digit	300ms

6. PAUSE AND P→T DURATION SELECTION TABLE

RK21	TP (sec)	TP→T (sec)
No	3.6	3.6
Yes	2	1

7. PULSE NUMBER SELECTION TABLE

- This table shows pulse number selections for SC9302X AND SC9302XT. The table for SC9302XLT is used to select IDD lock function.

RK31	RK41	Pulse Number
No	No	N
No	Yes	N + 1
Yes	No	10-N
Yes	Yes	--

- SC9302G has different selection method listed in the table below.

RK31	Pulse Number
No	N
Yes	10-N

8. PULSE NUMBER TABLE

Keypad	Output Pulse Number		
	Normal N	New Zealand (10-N)	Sweden/Denmark(N+1)
1	1	9	2
2	2	8	3
3	3	7	4
4	4	6	5
5	5	5	6
6	6	4	7
7	7	3	8
8	8	2	9
9	9	1	10
0	10	10	1
* / T	P→T	P→T	P→T
#	Ignored	Ignored	Ignored

9. HAND-FREE FUNCTION OPERATION

- Hand-free function table

Current State			Input			Next State	
$\overline{\text{HKS}}$	HFO	HDO	$\overline{\text{HDI}}$	HFI	$\overline{\text{HKS}}$	HFO	HDO
H	L	X	H	L	An	L	An
H	L	X	H	\uparrow	An	H	L
H	H	X	H	\uparrow	An	L	An
H	X	L	H	L	L	L	L
L	L	X	H	L	An	L	An
L	L	X	H	\uparrow	An	H	L
L	H	L	H	\uparrow	An	L	An
L	X	X	H	L	H	An	An
X	X	L	\downarrow	L	An	L	H

H: Logic HIGH X: Don't care L: Logic LOW An: Unchanged

\uparrow : Rising edge \downarrow : Falling edge

- Hand-free function execution

When HFO is low, a rising edge triggers the HFI, asserting the Hand-free function (HFO becomes high).

- Reset Hand-free function

When HFO is high, the Hand-free function is enabled and can be reset by:

- * Off-hook
- * Applying a rising edge to HFI
- * Changing the HDO pin from low to high

10. HOLD-LINE FUNCTION OPERATION

- Hold-line function execution

When HDO is low, a falling edge triggers the $\overline{\text{HDI}}$, asserting the Hold-line function (HDO becomes high). The $\overline{\text{XMUTE}}$ remains low when HDO is high.

- Reset Hold-line function

When HDO is high, the Hold-line function is enabled and can be reset by:

- * Off-hook.
- * Applying a falling edge to $\overline{\text{HDI}}$.
- * Changing the HFO pin from low to high.

- Hold-line function table

Current State			Input			Next State	
$\overline{\text{HKS}}$	HDO	HFO	HFI	$\overline{\text{HDI}}$	$\overline{\text{HKS}}$	HDO	HFO
H	L	X	L	H	An	L	An
H	L	X	L	\downarrow	An	H	L
H	H	L	L	\downarrow	An	L	An
H	X	X	L	H	L	L	L
L	L	X	L	H	An	L	An
L	L	X	L	\downarrow	An	H	L
L	H	L	L	\downarrow	An	L	An
L	X	X	L	H	H	An	An
X	X	L	\uparrow	H	An	L	H

H: Logic HIGH X: Don't care L: Logic LOW An: Unchanged

\uparrow : Rising edge \downarrow : Falling edge

11. DOUT BCD CODE

When dialing, the corresponding 4-bit BCD codes are serially presented on DOUT from MSB to LSB. The data of the DOUT is valid at the falling edge of the CLOCK pin. The following table lists the BCD codes corresponding to the keyboard input.

Key-In	BCD Code	Key-In	BCD Code
1	0001	8	1000
2	0010	9	1001
3	0011	0	1010
4	0100	*/T	1101
5	0101	#	1100
6	0110	F	1011
7	0111	P	1110

12. LOCK FUNCTION

The function aims to detect locked dialing number to prevent a long distance call. The dialing output of the chip is disabled if the first input key after on-off-hook is the locked number when the lock function is enabled. The lock function selection is listed below.

The SC9302X version is the pin-selected type; on the other hand, the SC9302XLT is the key-board operated type. However, the SC9302XT version does not support any lock function.

- SC9302X VERSION

LOCK Pin	Function
OPEN	Normal dialing (no lock)
VDD	"0, 9" is inhibited
Vss	"0" is inhibited

- SC9302XLT VERSION

RK31	RK41	Function
No	No	Keyboard operated IDD lock
No	Yes	Lock 0
Yes	No	Lock 0,9
Yes	Yes	All keys are locked

13. KEY DEFINITION

Key Name	Function
0,1,2,3,4,5,6,7,8,9 numerical keys	These are dialing number input keys for both the pulse mode and the tone mode operations.
*/T	This key executes the P→T function and waits a TP→T duration in the pulse mode. On the other hand, the */T key executes the * function in the tone mode.
#	This is a dialing signal key for the tone mode only, no response in the pulse mode.
SA	Pressing this key can save the preceding dialing telephone numbers. The saved number is redialed if it is pressed again. SA will also redial the saved number if it is the first key depressed at the off-hook state. During the dialing signal transmission, the SA key is inhibited.

• ONE-KEY REDIAL

---Pulse Mode

a) without */T

Keyboard input: $\boxed{D1} \boxed{D2} \dots \boxed{Dn} \boxed{R}$

Dialing output: D1D2 ... Dn TBRK TRP D1D2... Dn

RM: D1 D2 ... Dn

SAM: Unchanged

b) with */T

Keyboard input: $\boxed{D1} \boxed{D2} \dots \boxed{Dn} \boxed{*/T} \boxed{Dn+1} \dots \boxed{Dm} \boxed{R}$

Dialing output: $\boxed{D1} \boxed{D2} \dots \boxed{Dn} \boxed{TP \rightarrow T} \boxed{Dn+1} \dots \boxed{Dm}$

TBRK

	Pulse		Tone
TRP	D1 D2 ... Dn	TP→T	Dn+1...Dm
	Pulse		Tone

RM: D1 D2 ... Dn */T Dn+1...Dm

SAM: Unchanged

---Tone Mode

a) without */T

Keyboard input: $\boxed{D1} \boxed{D2} \dots \boxed{Dn} \boxed{R}$

Dialing output: D1D2... Dn TBRK TRP D1D2... Dn

RM: D1 D2 ... Dn

SAM: Unchanged

b) with */T

Keyboard input: $\boxed{D1} \boxed{D2} \dots \boxed{Dn} \boxed{*/T} \boxed{Dn+1} \dots \boxed{Dm}$

\boxed{R}

Dialing output: D1 D2 ... Dn * Dn+1...Dm TBRK

TRP D1 D2 ... Dn * Dn+1...Dm

RM: D1 D2 ... Dn * Dn+1...Dm

SAM: Unchanged

Note: If the dialing number is over 32 digits, the redialing is inhibited and $\overline{PO} = VDD$.

• SA COPY

---Pulse Mode

a) without */T

Keyboard input: $\boxed{D1} \boxed{D2} \dots \boxed{Dn} \boxed{SA}$

Dialing output: D1 D2 ... Dn

RM: D1 D2... Dn

SAM: D1 D2 ... Dn

b) with */T

Keyboard input: $\boxed{D1} \boxed{D2} \dots \boxed{Dn} \boxed{*/T} \boxed{Dn+1} \dots \boxed{Dm}$

\boxed{SA}

Dialing output: D1 D2 ... Dn TP→T Dn+1...Dm

	Pulse		Tone
--	-------	--	------

RM: D1 D2 ... Dn */T Dn+1...Dm

SAM: D1 D2 ... Dn */T Dn+1...Dm

---Tone Mode

a) without */T

Keyboard input: $\boxed{D1} \boxed{D2} \dots \boxed{Dn} \boxed{SA}$

Dialing output: D1 D2 ... Dn

RM: D1 D2 ... Dn

SAM: D1 D2 ... Dn

b) with */T

Keyboard input: $\boxed{D1} \boxed{D2} \dots \boxed{Dn} \boxed{*/T} \boxed{Dn+1} \dots \boxed{Dm}$

\boxed{SA}

Dialing output: D1 D2 ... Dn * Dn+1...Dm

RM: D1 D2 ... Dn * Dn+1...Dm

SAM: D1 D2 ... Dn * Dn+1...Dm

Note: The maximum capacity of the RM memory is 32 digits. When over 32 digits plus the "SA" key are entered, the SAVE function will not be executed, and all the existing data in the save memory will not be changed.

• SA DIALING

---Pulse Mode

a) without */T

SAM content: D1 D2 ... Dn

Keyboard input: SA

Dialing output: D1 D2 ... Dn

RM: Unchanged

SAM: Unchanged

b) with */T

SAM content: D1 D2 ... Dn */T Dn+1...Dm

Keyboard input: SA

Dialing output: D1 D2 ... Dn TP→T Dn+1...Dm
Pulse Tone

RM: Unchanged

SAM: Unchanged

• FLASH

---Flash as a digital key

a) The intervenient key

Keyboard input: D1 D2 ... Dn F Dn+1 ... Dm

Dialing output: D1 D2 ... Dn TF TFP Dn+1...Dm

RM: D1 D2 ... Dn

SAM: Unchanged

b) The first key

Keyboard input: F D1 D2 ... Dn

Dialing output:

TF TFP D1 D2 ... Dn

RM: Unchanged

SAM: Unchanged

• PAUSE

Keyboard input: D1 D2 ... Dn P Dn+1 ... Dm

Dialing output: D1 D2 ... Dn TP Dn+1...Dm

RM: P Dn+1...Dm

SAM: Unchanged

---Tone Mode

a) without */T

SAM content: D1 D2 ... Dn

Keyboard input: SA

Dialing output: D1 D2 ... Dn

RM: Unchanged

SAM: Unchanged

b) with */T

SAM content: D1 D2 ... Dn * Dn+1...Dm

Keyboard input: SA

Dialing output: D1 D2 ... Dn * Dn+1...Dm

RM: Unchanged

SAM: Unchanged

---Flash as a control key

Keyboard input: D1 D2 ... Dn F Dn+1 ... Dm

Dialing output: D1 D2 ... Dn TF TFP Dn+1...Dm

RM: Dn+1...Dm

SAM: Unchanged

Note: TF: break a flash time

• NOTE

RM: Redial memory

SAM: Save dialing memory

D1 D2 ... Dn: 0~9

Dn+1...Dm: 0~9, *, #

- IDD lock operation by the keyboard (2 lock numbers, 3 digits/number at maximum)

---Personal / lock No.1 / Lock No.2 input operation

a) Personal code doesn't exist

Stores Personal Code: ST D1 D2 D3 ST * 0

Stores Lock No.1: ST D4 D5 D6 ST * 1

Stores Lock No.2: ST D7 D8 D9 ST * 2

b) Personal code exist

Changes Personal Code: ST D1 D2 D3 ST # ST D4 D5 D6 ST * 0

(Old personal code) (New personal code)

Changes Lock No.1: ST D1 D2 D3 ST # ST D4 D5 D6 ST * 1

(personal code) (Lock No.1)

Changes Lock No.2: ST D1 D2 D3 ST # ST D7 D8 D9 ST * 2

(personal code) (Lock No.2)

Changes Personal Code, Lock No.1 and Lock No.2 at one time

ST D1 D2 D3 ST # ST D4 D5 D6 ST * 0 (continued)

(Old personal code) (New personal code)

ST D7 D8 D9 ST # ST D10 D11 D12 ST * 2

(Lock No.1) (Lock No.2)

---Personal / lock No.1 / Lock No.2 cancel operation

Cancels Personal Code: ST D1 D2 D3 ST # ST # 0

Cancels Lock No.1: ST D1 D2 D3 ST # ST # 1

Cancels Lock No.2: ST D1 D2 D3 ST # ST # 2

---Temporary release both of the lock numbers (Lock No.1, Lock No.2):

ST D1 D2 D3 ST # Dm Dm+1 Dm+2 D1...Dn

(Personal code)

Note: D1~D12=0~9

Dm Dm+1 Dm+2 = 0~9

D1...Dn = 0~9, *, #

- Note:

RM: Redial memory

SAM: Save dialing memory

D1 D2...Dn: 0~9

Dn+1...Dm: 0~9, *, #

Dm+1...Dl: 0~9, *, #

Dl+1...Dk: 0~9, *, #

OPERATION TIMING

1. NORMAL DIALING

• PULSE MODE

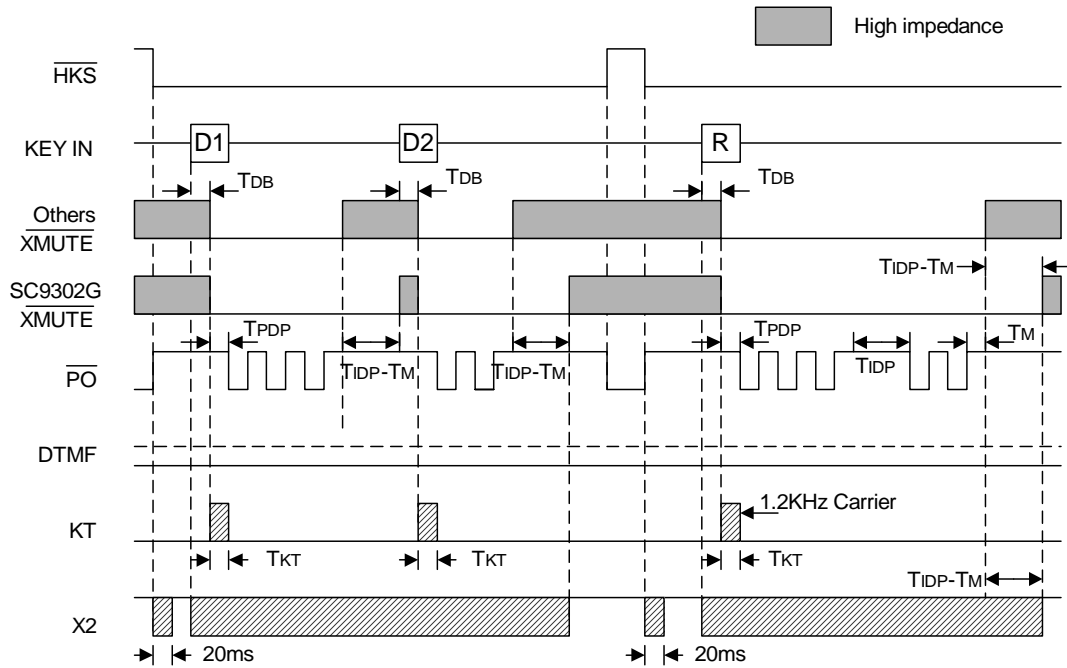

• TONE MODE

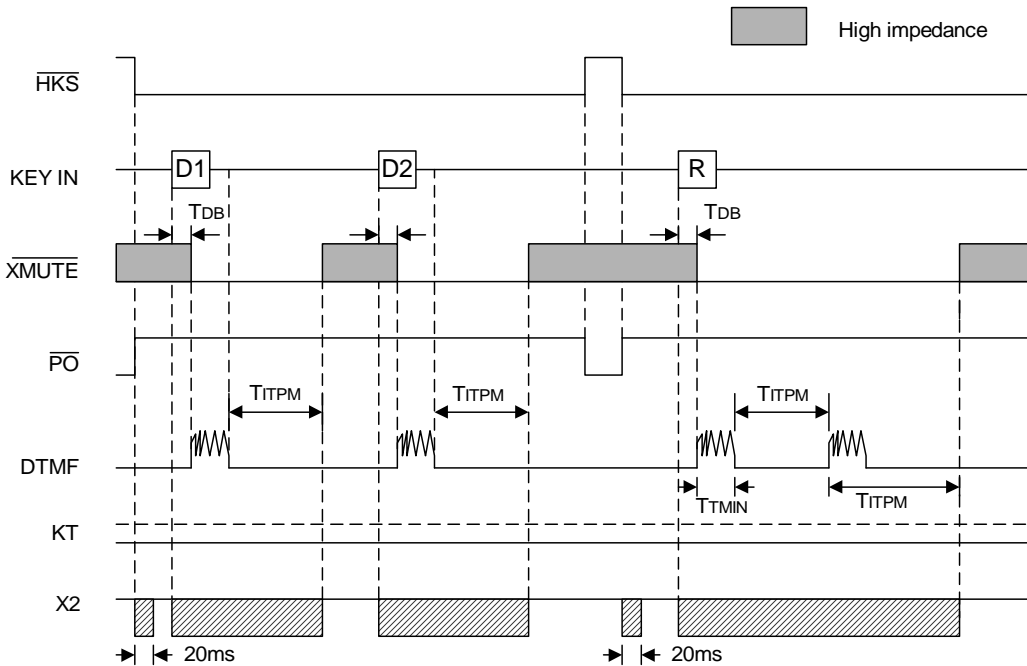

2. DIALING WITH PAUSE KEY

• PULSE MODE

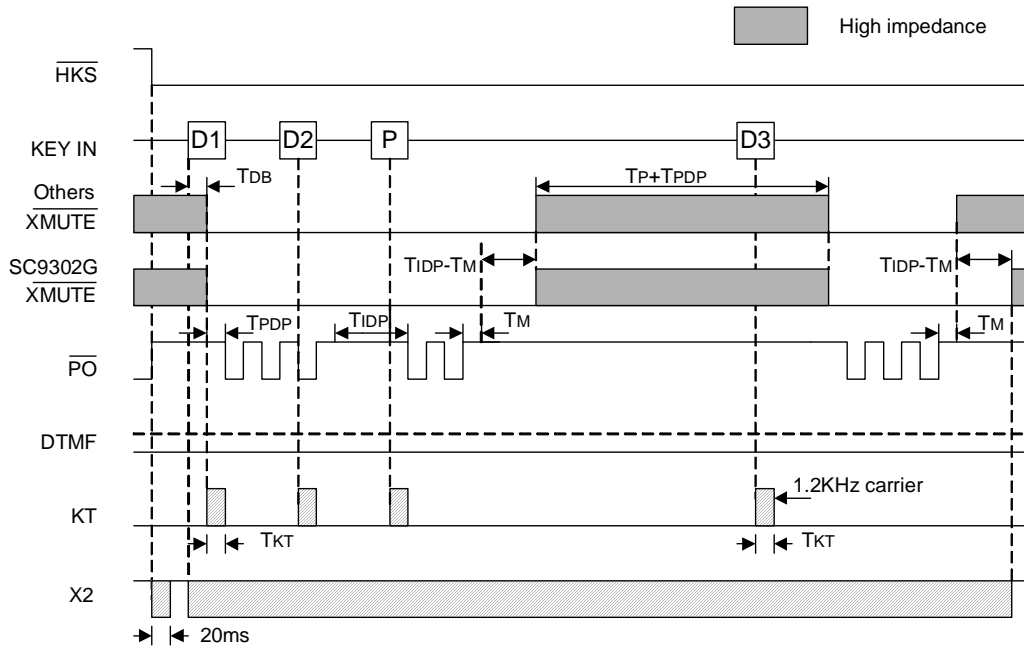

• TONE MODE

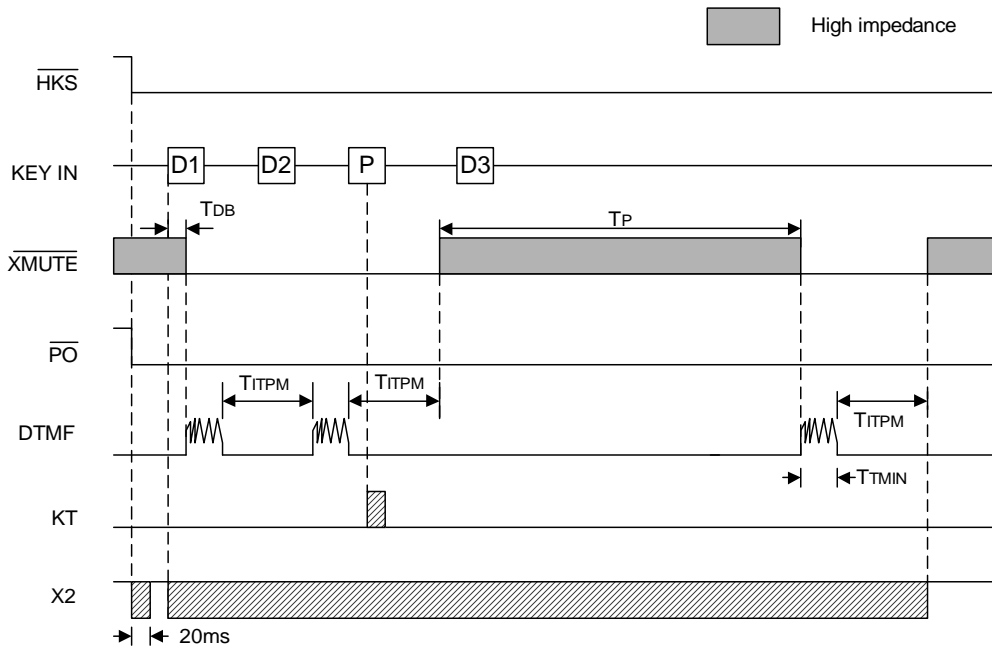

3. FLASH KEY OPERATION

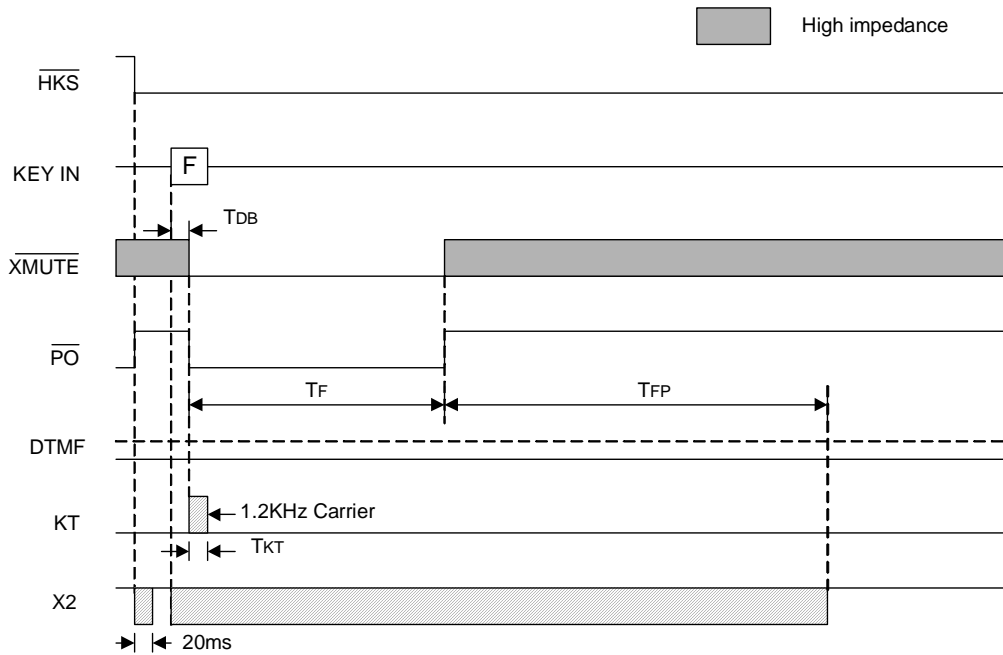

4. PULSE→TONE OPERATION

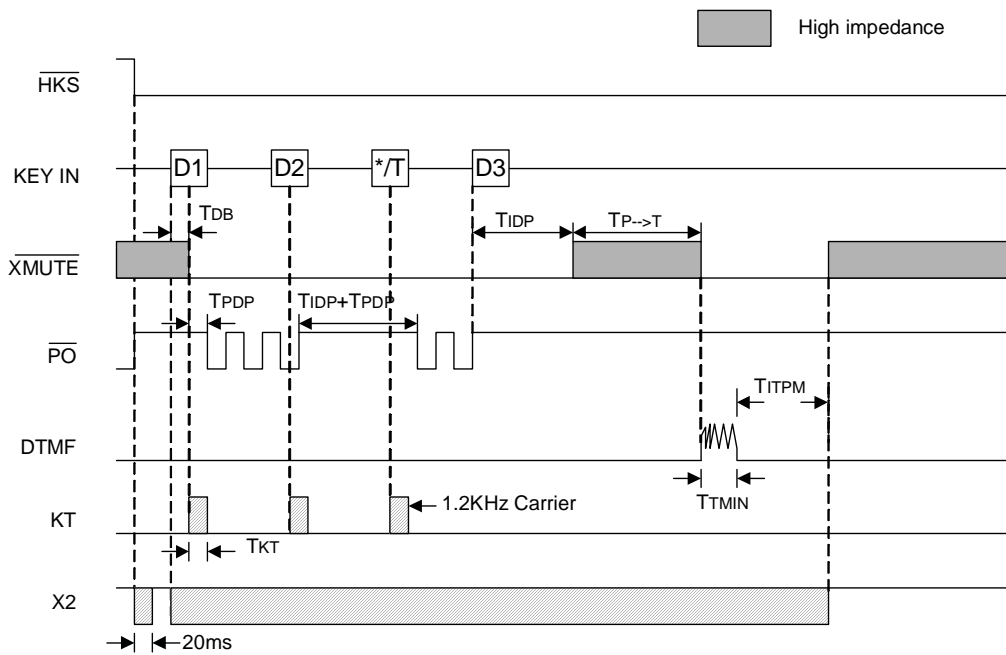

5. ONE KEY REDIAL OPERATION

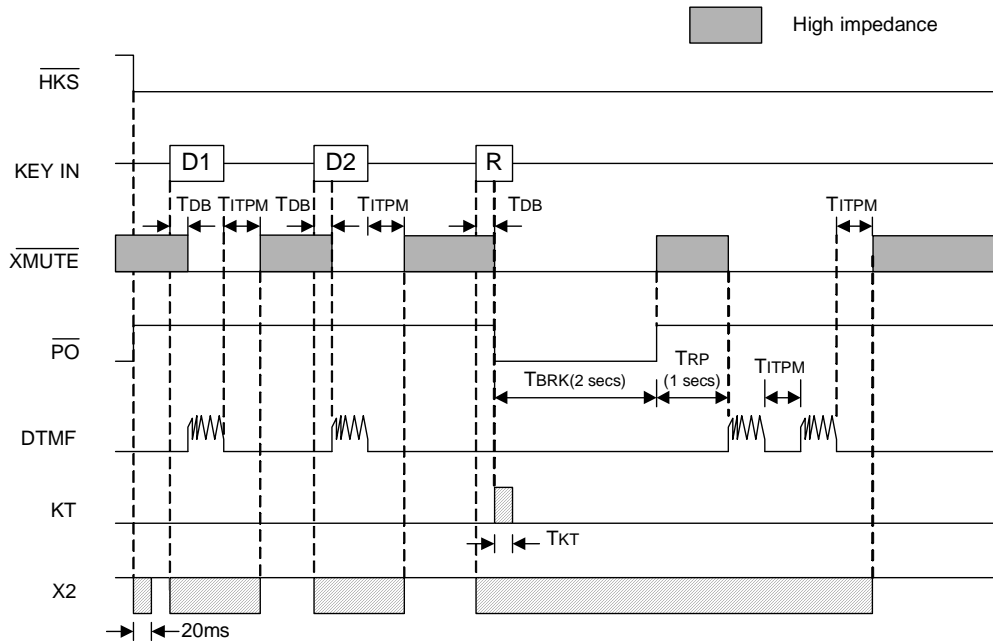

6. CLOCK & DOUT OPERATION

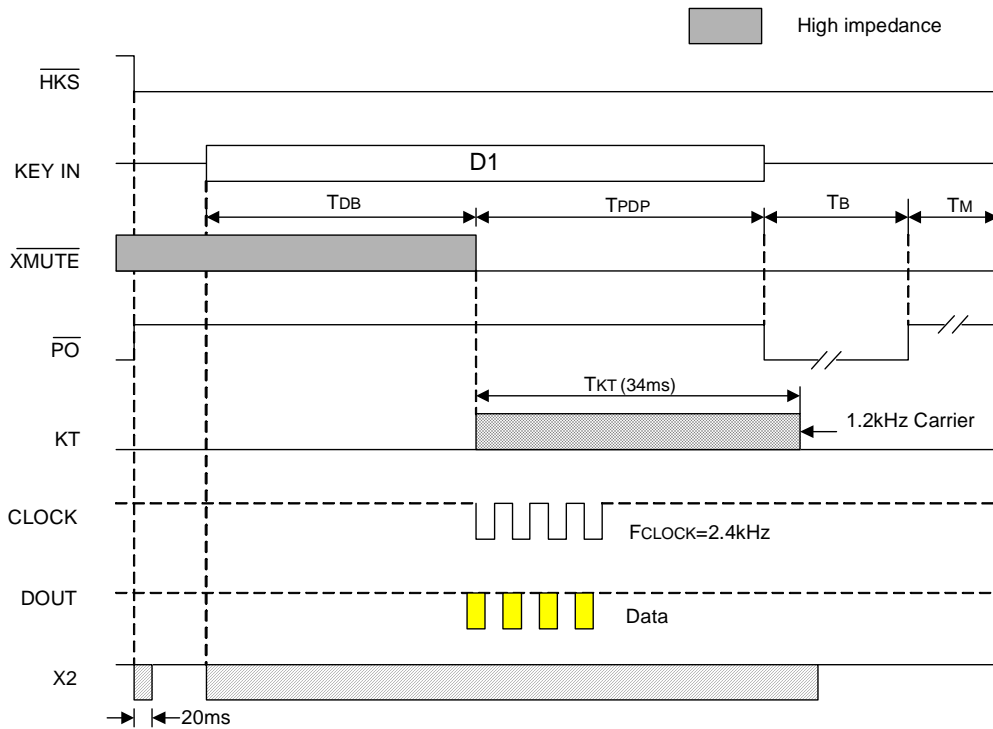

Note: D1=D3=3, D2=2.

TYPICAL APPLICATIONS

1. SC9302A (DIP-18)

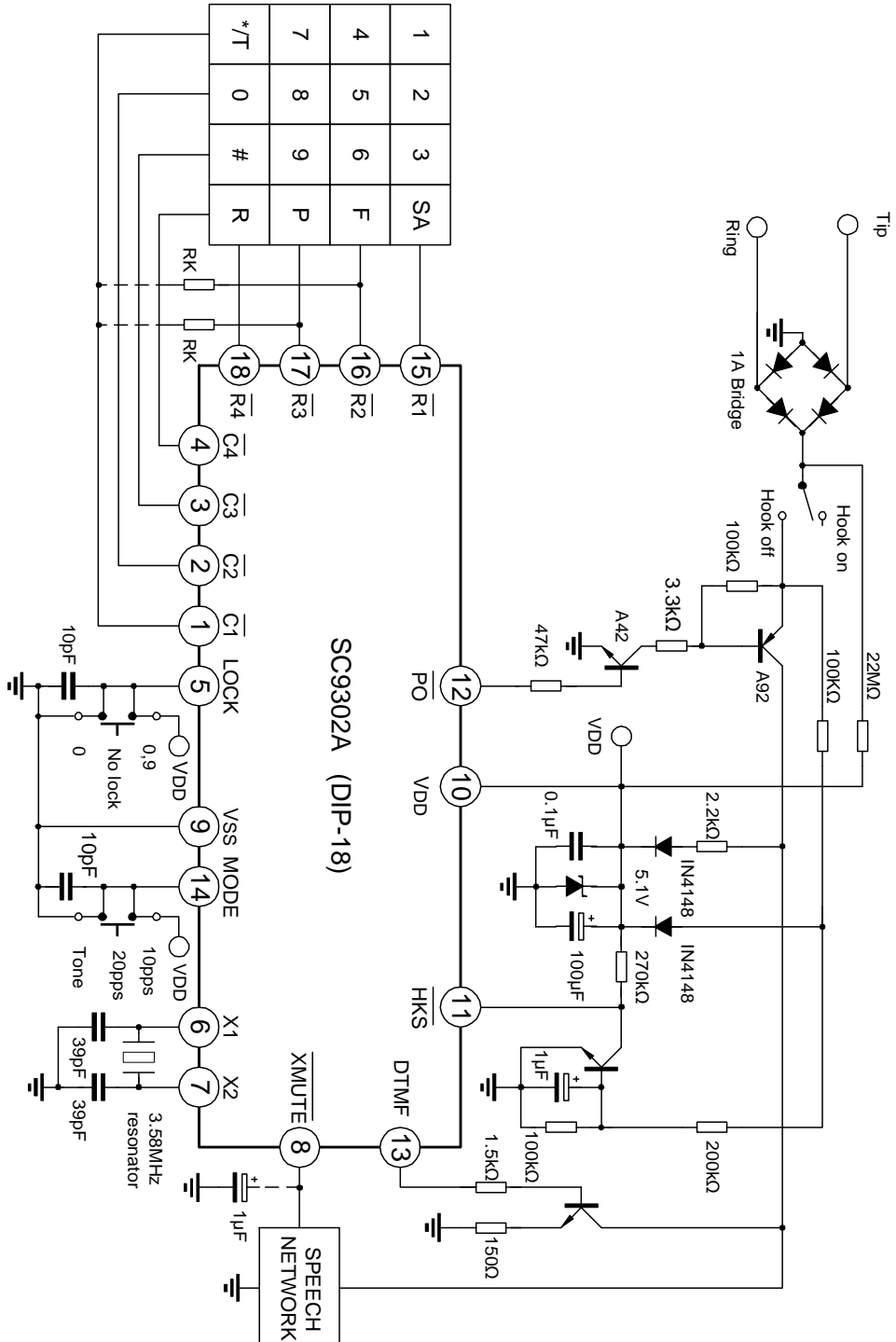

* RK for dialing signal option. (Refer to the functional description)

* Unmarked transistors are of 8050 type.

* A 1μF capacitor between XMUTE and Vss (GND) is recommended.

2. SC9302B (SDIP-22)

- * RK for dialing signal option. (Refer to the functional description)
- * Unmarked transistors are of 8050 type.
- * A 1 μ F capacitor between XMUTE and Vss (GND) is recommended.
- * The melody IC provides a melody during the hold period.

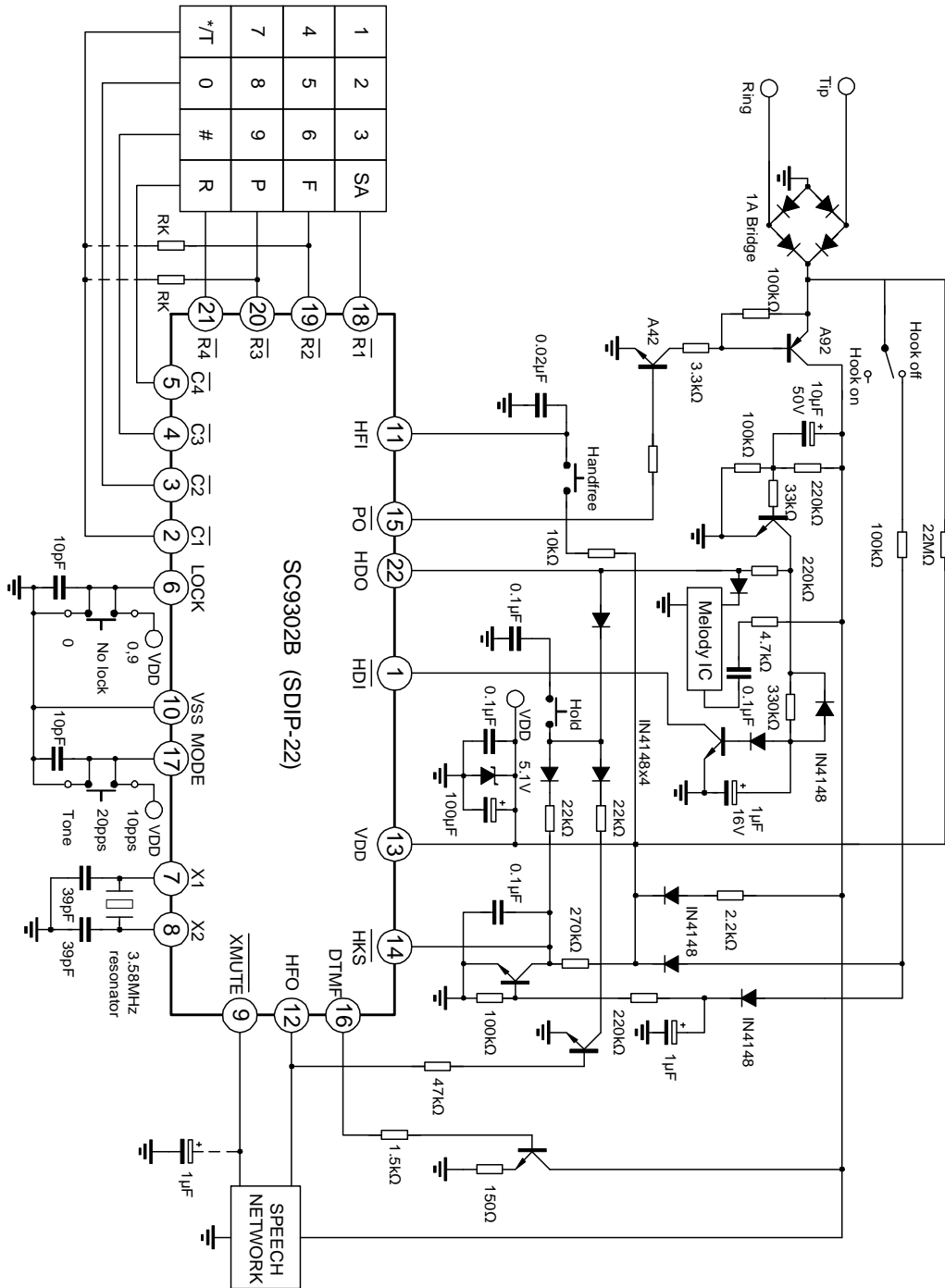

5. SC9302AT/ALT (DIP-18)

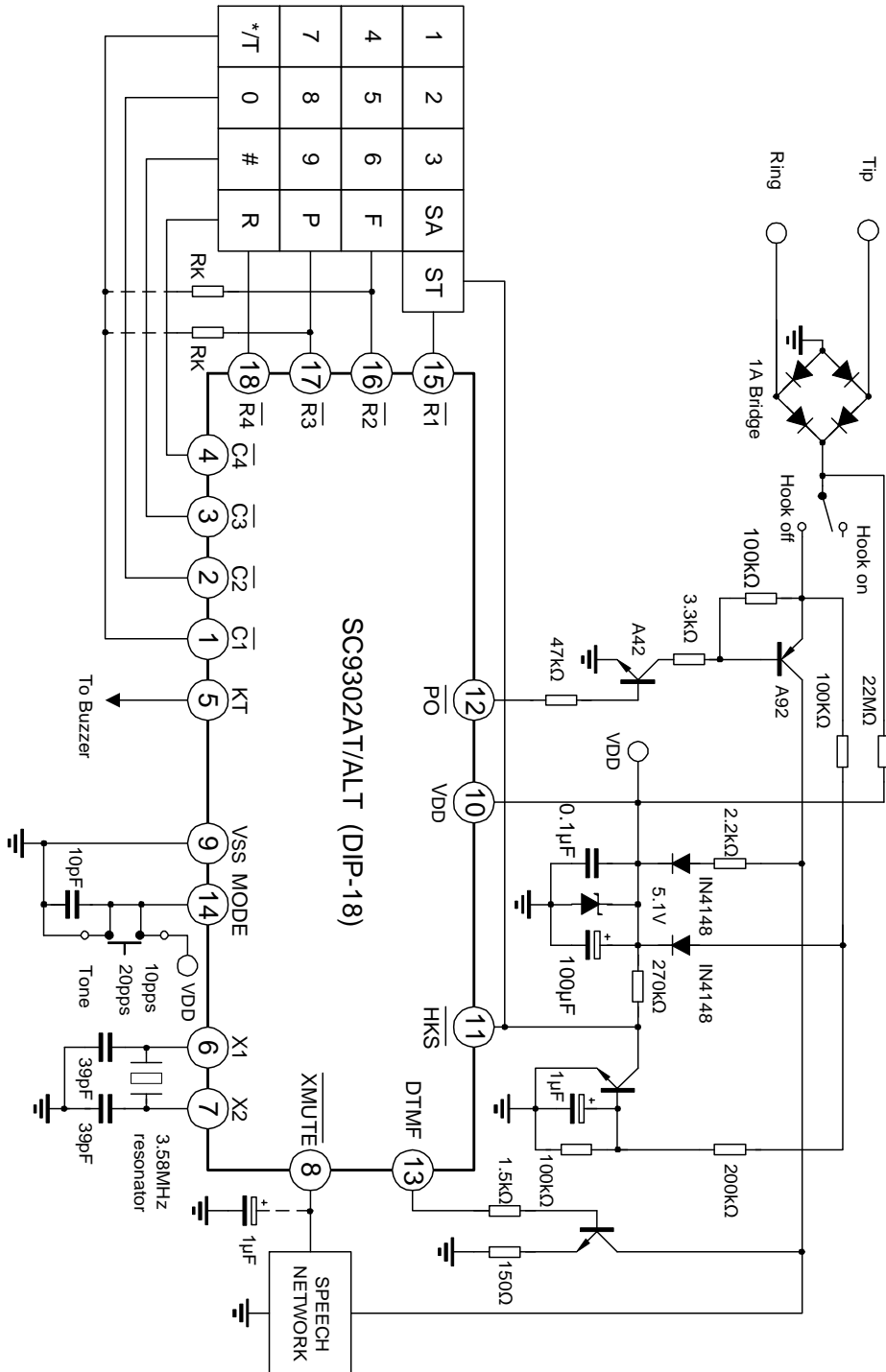

- * RK for dialing signal option. (Refer to the functional description)
- * Unmarked transistors are of 8050 type.
- * A 1μF capacitor between $\overline{\text{XMUTE}}$ and Vss (GND) is recommended.

6. SC9302BT/BLT (SDIP-22)

- * RK for dialing signal option. (Refer to the functional description)
- * Unmarked transistors are of 8050 type.
- * A 1 μ F capacitor between XWUTE and Vss (GND) is recommended.
- * The Melody IC provides a melody during the hold period.

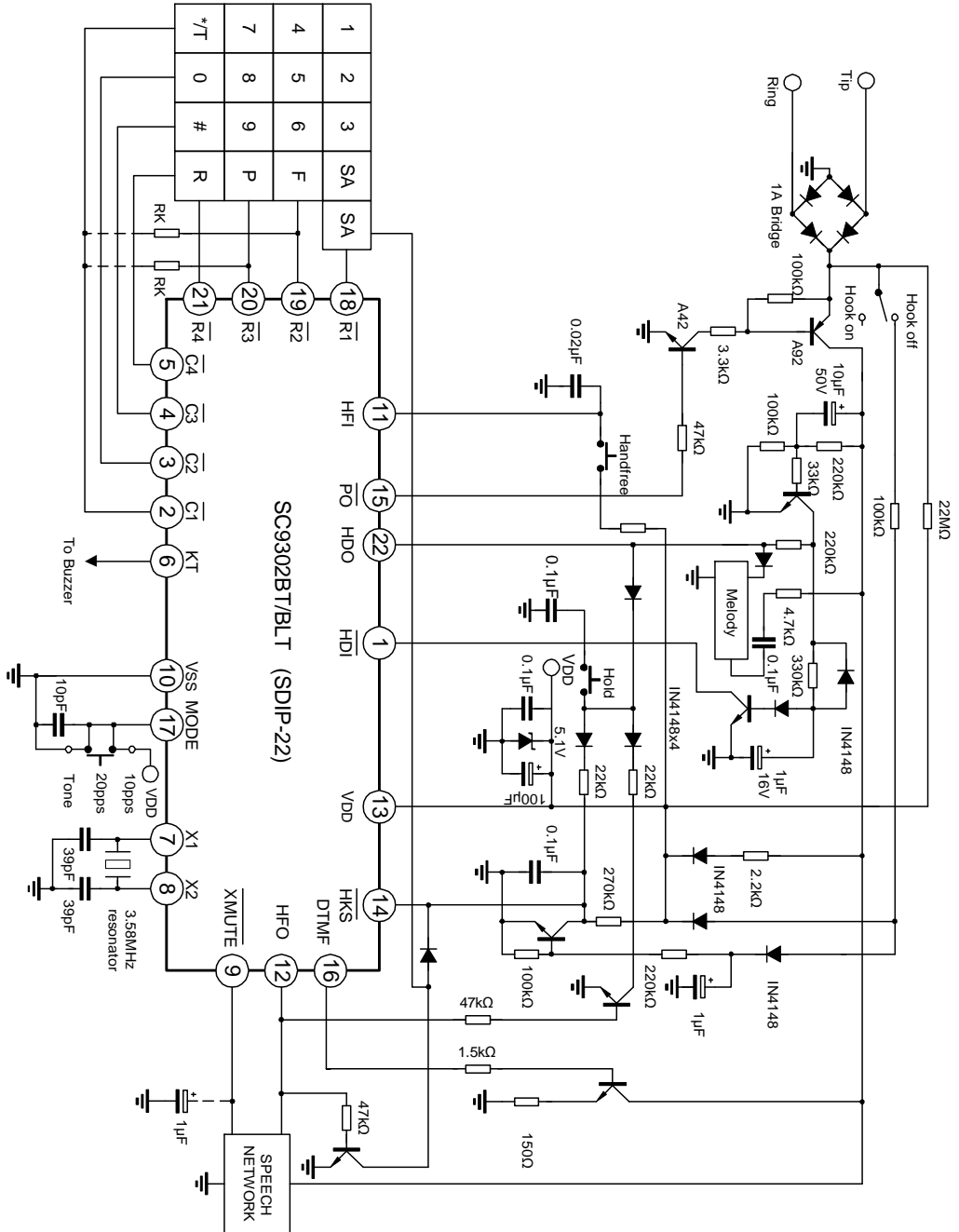

7. SC9302CT/CLT (DIP-20)

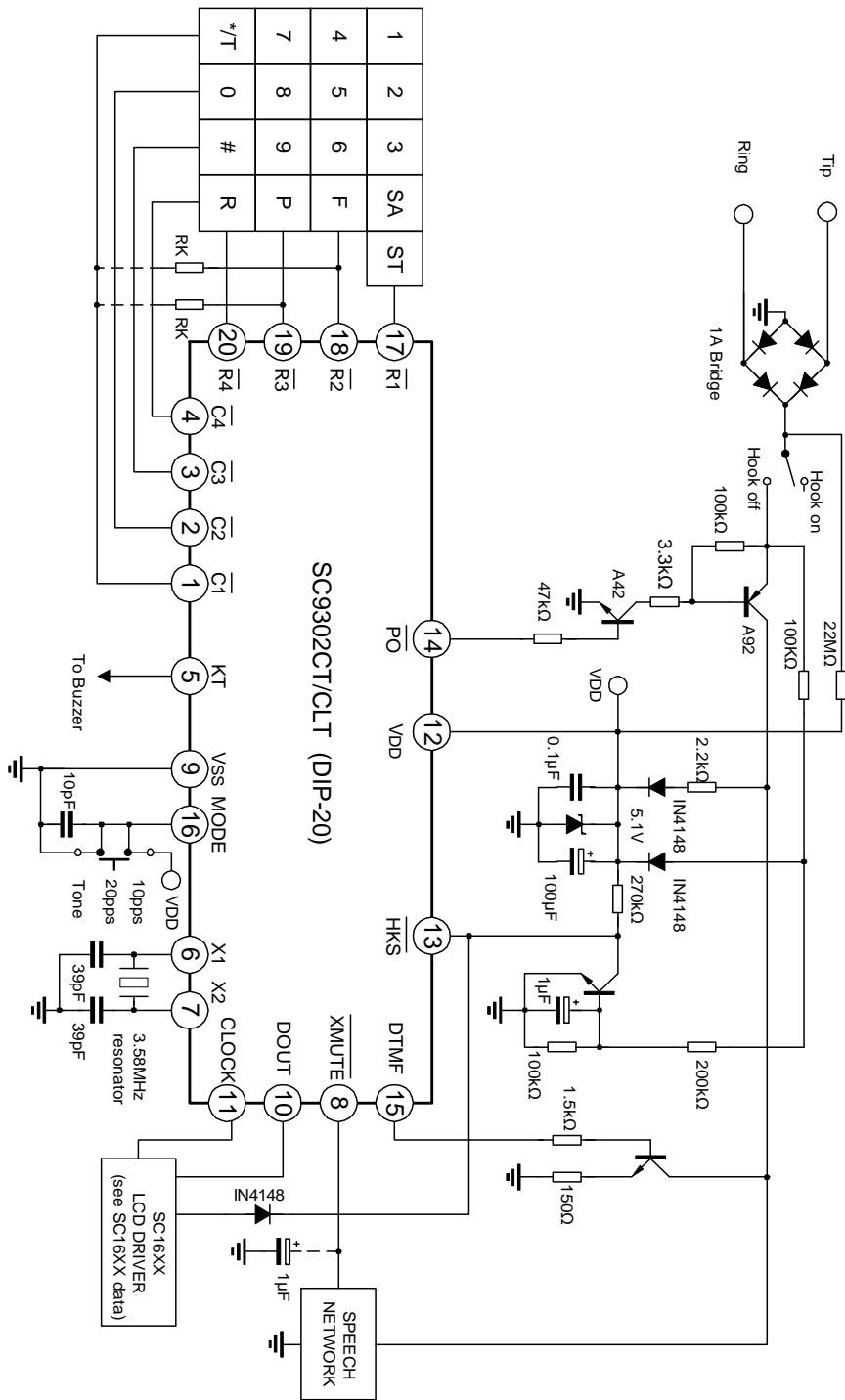

- * RK for dialing signal option. (Refer to the functional description)
- * Unmarked transistors are of 8050 type.
- * A 1µF capacitor between $\overline{\text{XMUTE}}$ and Vss (GND) is recommended.

8. SC9302DT/DLT (SDIP-24)

- * RK for dialling signal option. (Refer to the functional description)
- * Unmarked transistors are of 8050 type.
- * A 1 μ F capacitor between $\overline{\text{XMUTE}}$ and Vss (GND) is recommended.
- * The Melody IC provides a melody during the hold period.

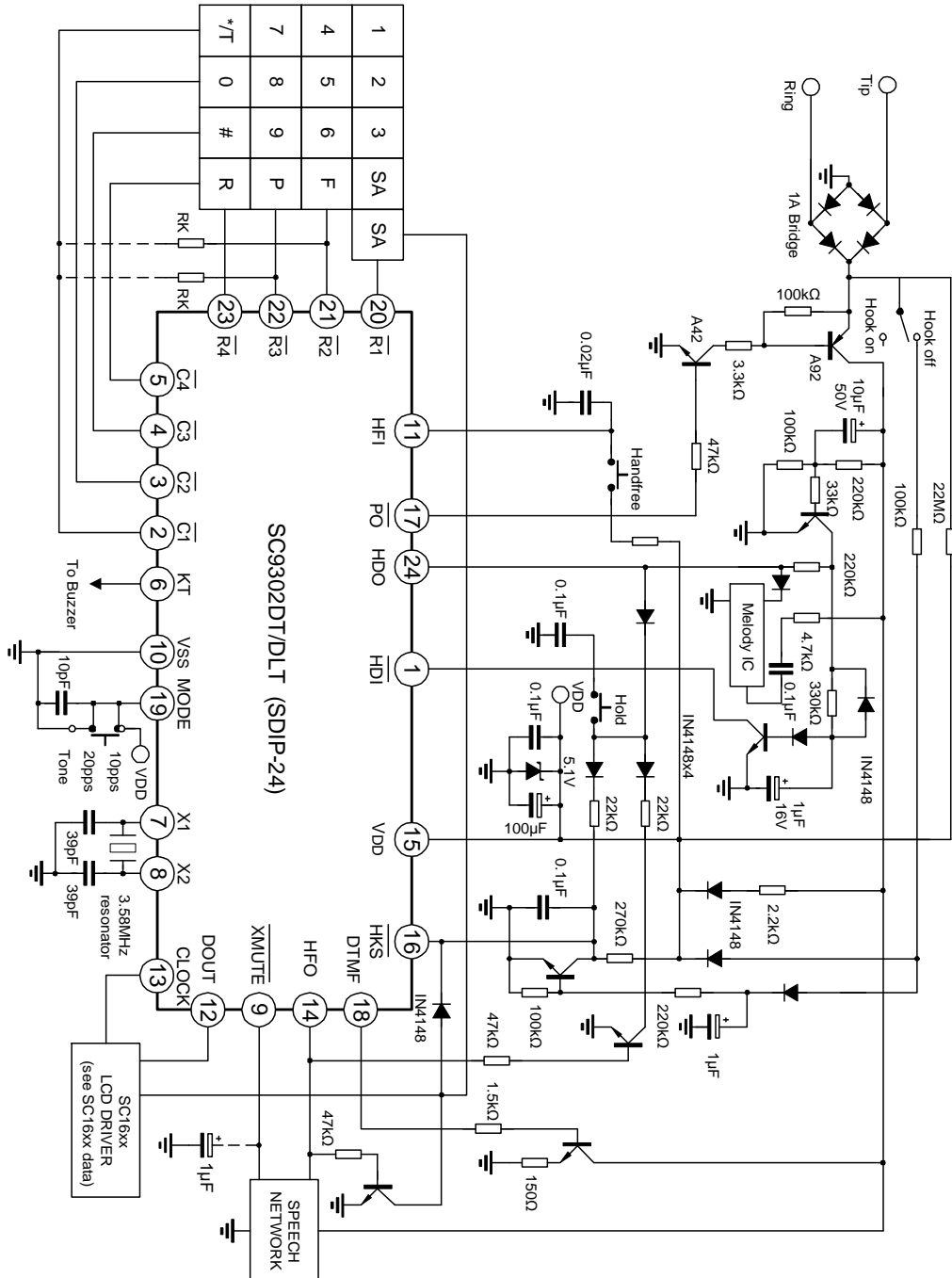

9. SC9302H (DIP-18)

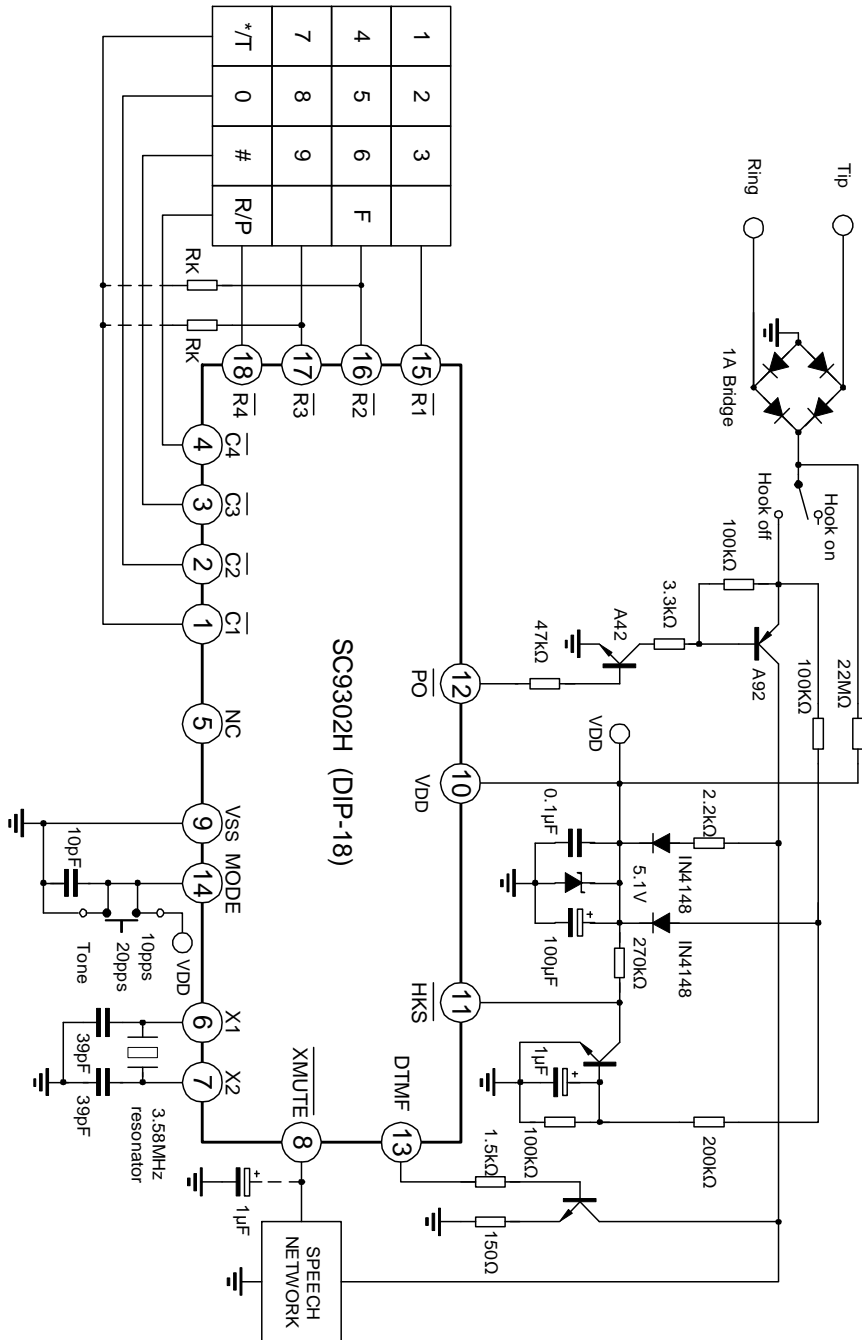

* RK for dialing signal option. (Refer to the functional description)

* Unmarked transistors are of 8050 type.

* A 1µF capacitor between $\overline{\text{XMUTE}}$ and Vss (GND) is recommended.

10. SC9302G (DIP-16)

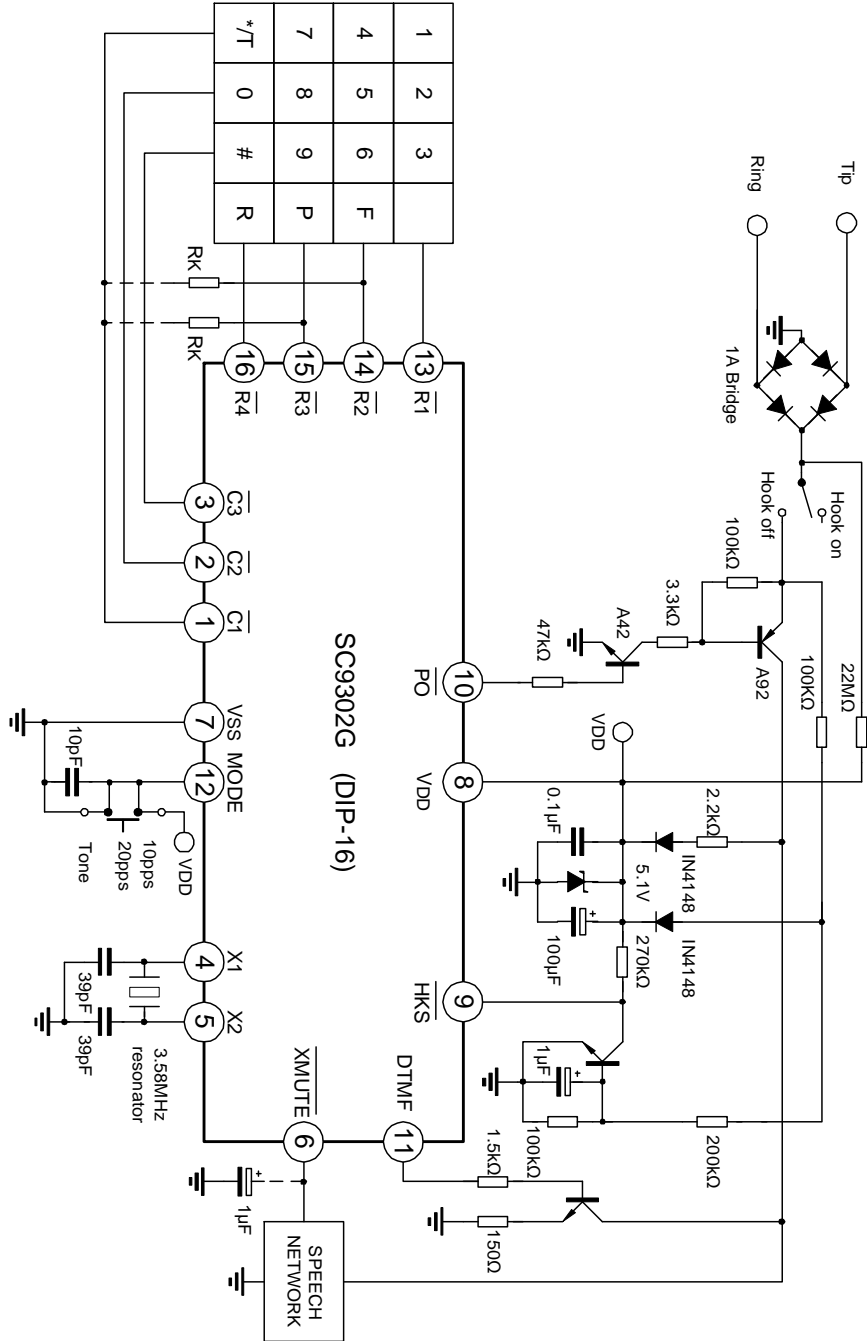

- * RK for dialing signal option. (Refer to the functional description)
- * Unmarked transistors are of 8050 type.
- * A 1µF capacitor between $\overline{\text{XMUTE}}$ and Vss (GND) is recommended.

11. SC9302F (DIP-18)

- * RK for dialling signal option. (Refer to the functional description)
- * Unmarked transistors are of 8050 type.
- * A 1 μ F capacitor between $\overline{\text{XMUTE}}$ and Vss (GND) is recommended.

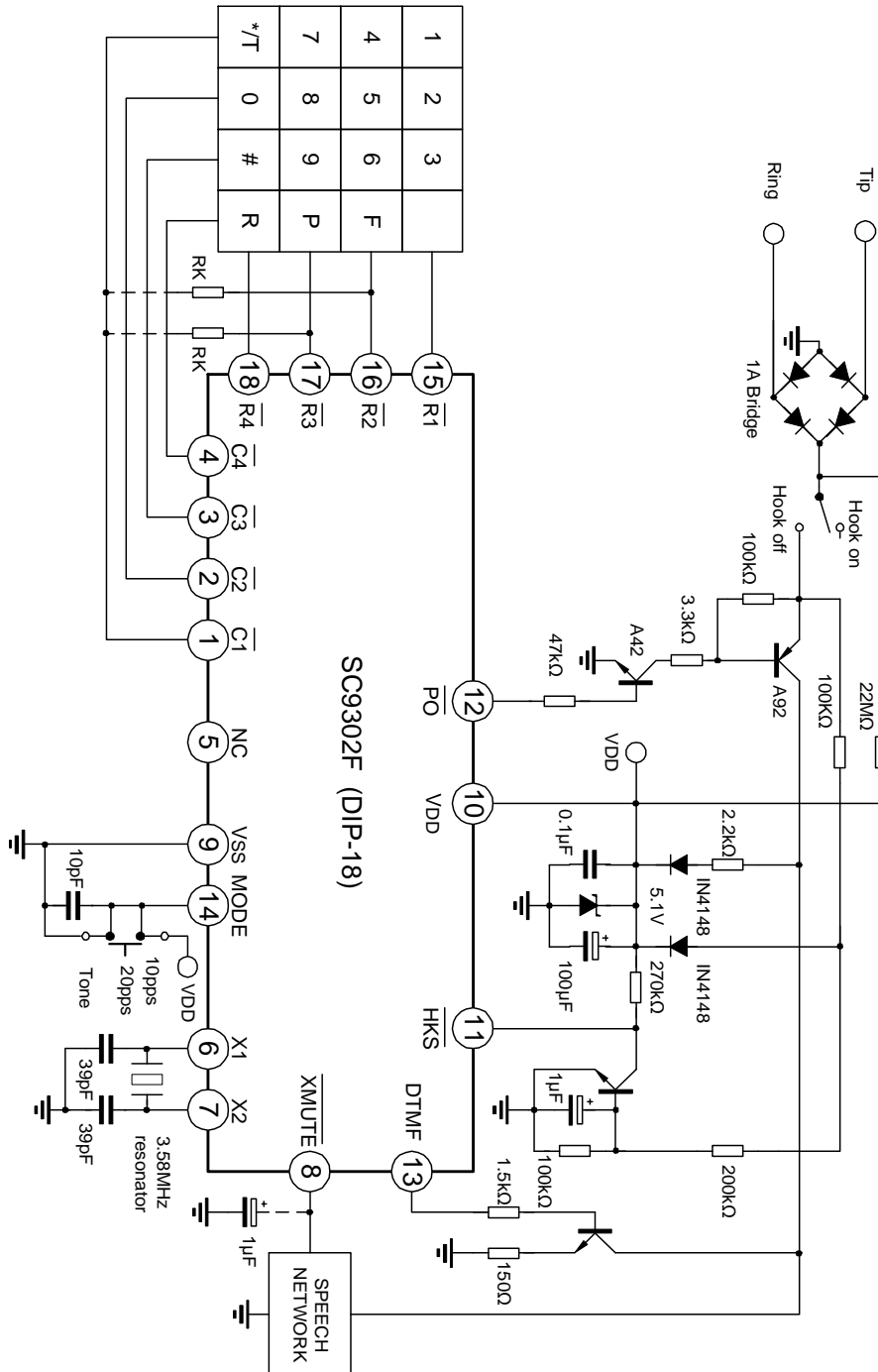

CHIP TOPOGRAPHY

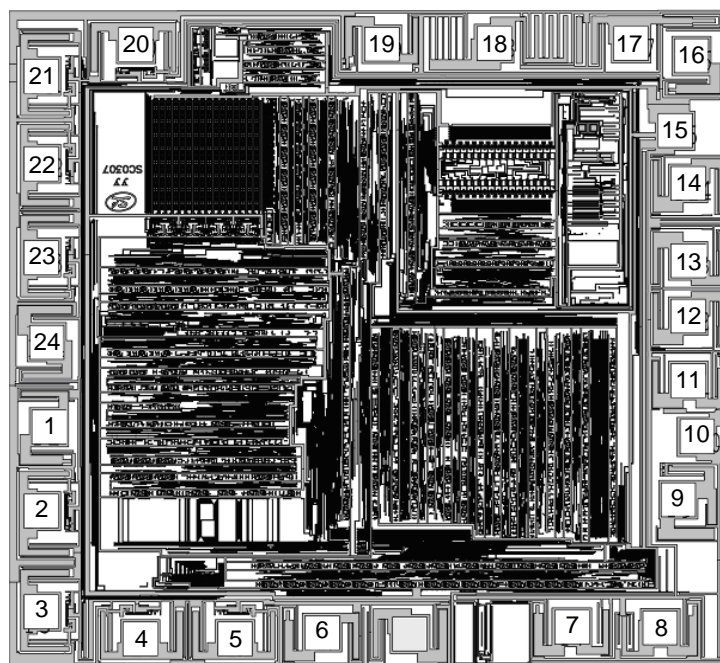

Chip size: 1.90 x 1.73 mm²

PAD COORDINATES (Unit: μm)

Pad No.	Symbol	X	Y	Pad No.	Symbol	X	Y
1	P1	-934.05	-225.30	13	P13	927.70	234.85
2	P2	-956.65	-503.00	14	P14	927.70	463.25
3	P3	956.65	-800.20	15	P15	890.75	619.10
4	P4	-668.20	-879.95	16	P16	937.55	839.50
5	P5	-391.80	-879.95	17	P17	761.90	875.45
6	P6	-137.60	-861.45	18	P18	363.20	875.45
7	P7	589.50	-845.65	19	P19	35.90	873.65
8	P8	846.10	-847.35	20	P20	-679.90	873.35
9	P9	899.15	-469.80	21	P21	-956.65	779.70
10	P10	954.35	-283.90	22	P22	-956.65	521.30
11	P11	927.70	-117.95	23	P23	-956.65	244.90
12	P12	927.70	71.75	24	P24	-940.35	-5.70

Note: The original point of the coordinate is the die center.

PACKAGE OUTLINE

DIP-16-300-2.54

UNIT: mm

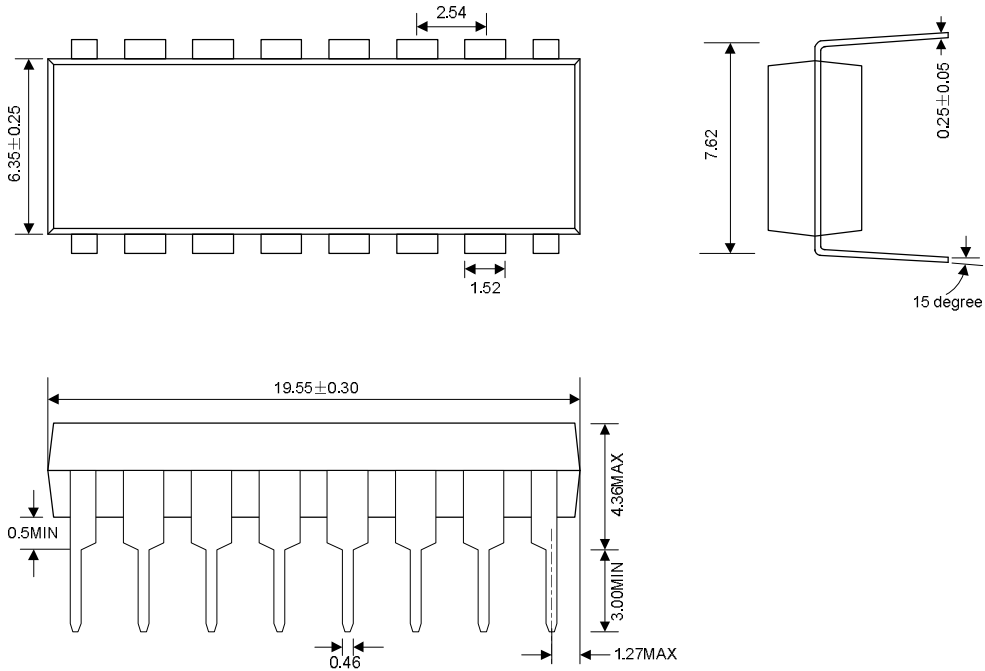

DIP-18-300-2.54

UNIT: mm

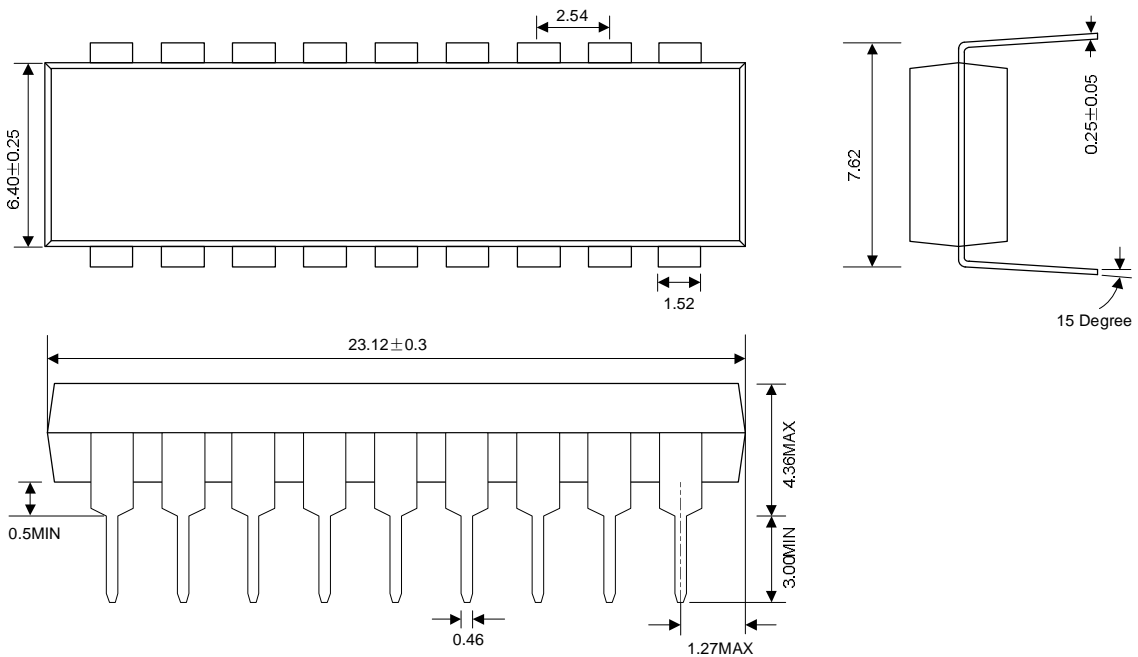

PACKAGE OUTLINE

DIP-20-300-2.54

UNIT: mm

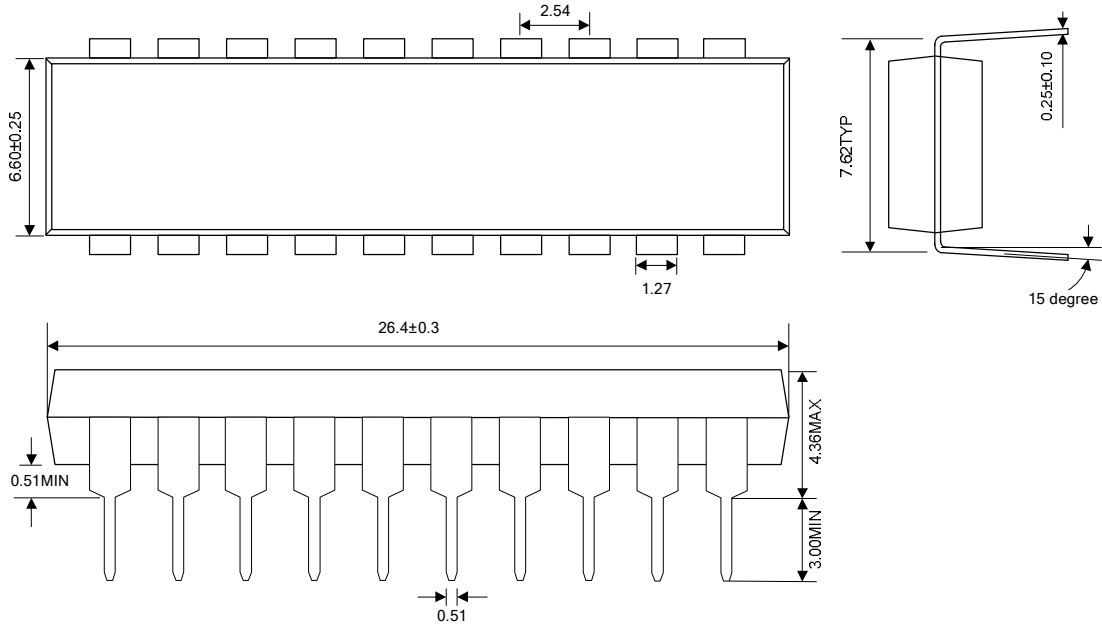

SDIP-24-300-2.54

UNIT: mm

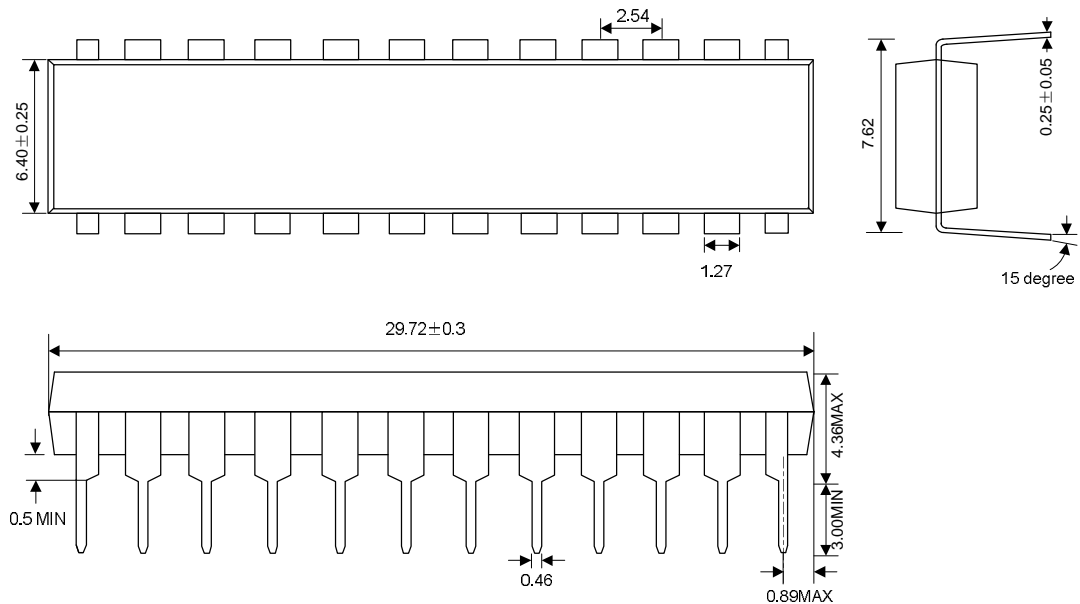



HANDLING MOS DEVICES:

Electrostatic charges can exist in many things. All of our MOS devices are internally protected against electrostatic discharge but they can be damaged if the following precautions are not taken:

- Persons at a work bench should be earthed via a wrist strap.
- Equipment cases should be earthed.
- All tools used during assembly, including soldering tools and solder baths, must be earthed.
- MOS devices should be packed for dispatch in antistatic/conductive containers.