

SCAN16602

Low Voltage Universal 16-bit IEEE 1149.1 Bus Transceiver with TRI-STATE® Outputs

General Description

The SCAN16602 is a high speed, low-power universal bus transceiver featuring data inputs organized into two 8-bit bytes with separate output enable and latch enable control signals. The byte-wide output enable controls are complementary to allow direction control with a single R/W line and no additional logic. This function is configurable as a D-type Latch or Flip-Flop, and can operate in transparent, latched, or clocked mode. This device is compliant with IEEE 1149.1 Standard Test Access Port and Boundary Scan Architecture with the incorporation of the defined boundary-scan test logic and test access port consisting of Test Data Input (TDI), Test Data Out (TDO), Test Mode Select (TMS), Test Clock (TCK), and Test Reset (TRST).

Features

- IEEE 1149.1 (JTAG) Compliant
- 2.7V to 3.6V V_{CC} Operation
- TRI-STATE outputs for bus-oriented applications
- Dual byte-wide data for bus applications
- Power down high Impedance inputs and outputs
- Optional Bus Hold on data inputs eliminates the need for external pullup/pulldown resistors (SCANH16602, SCANH162602 versions)
- Optional 25Ω series resistors in outputs to minimize noise and eliminate termination resistors (SCAN162602, SCANH162602 versions)
- Supports live insertion/withdrawal
- Includes CLAMP and HIGHZ instructions

Block Diagram

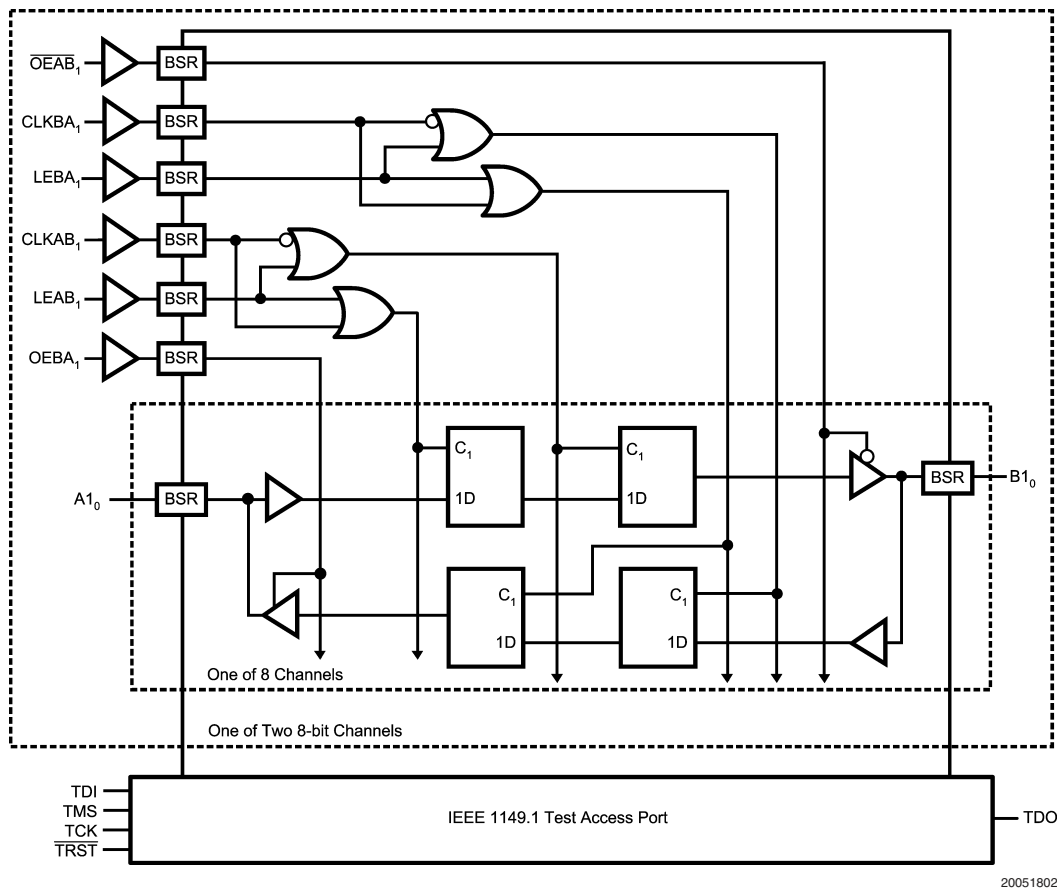

TRI-STATE® is a registered trademark of National Semiconductor Corporation.

Pin Descriptions

Pin Name	Description
A1 ₀ -A1 ₇ , A2 ₀ -A2 ₇	Normal-function A-bus I/O ports. See function table for normal-mode logic.
B1 ₀ -B1 ₇ , B2 ₀ -B2 ₇	Normal-function B-bus I/O ports. See function table for normal-mode logic.
CLKAB ₁ , CLKBA ₁ , CLKAB ₂ , CLKBA ₂	Normal-function clock inputs. See function table for normal-mode logic.
GND	Ground
V _{CC}	Supply Voltage
LEAB ₁ , LEBA ₁ , LEAB ₂ , LEBA ₂	Normal-function latch enables. See function table for normal-mode logic.
$\overline{\text{OEAB}}_1$, OEBA ₁ , $\overline{\text{OEAB}}_2$, OEBA ₂	Normal-function output enables. See function table for normal-mode logic.
TDO	The Test Data Output to support IEEE Std 1149.1-1990. TDO is the serial output for shifting data through the instruction register or selected data register.
TMS	The Test Mode Select input to support IEEE Std 1149.1-1990. TMS directs the device through its TAP controller states. An internal pull-up forces TMS high if left unconnected.
TCK	The Test Clock input to support IEEE Std 1149.1-1990. Test operations of the device are synchronous to TCK. Data is captured on the rising edge of TCK and outputs change on the falling edge of TCK.
TDI	The Test Data Input to support IEEE Std 1149.1-1990. TDI is the serial input to shift data through the instruction register or the selected data register. An internal pull-up resistor forces TDI high if left unconnected.
$\overline{\text{TRST}}$	The Test Reset Input to support IEEE Std 1149.1-1990. TRST is the asynchronous reset pin which will force the TAP controller to its initialization state when active. An internal pullup resistor forces $\overline{\text{TRST}}$ high if left unconnected.

BGA Pinout

	1	2	3	4	5	6	7	8
A	A1 ₀	A1 ₂	A1 ₄	A1 ₆	A2 ₀	A2 ₂	A2 ₄	A2 ₆
B	A1 ₁	A1 ₃	A1 ₅	A1 ₇	A2 ₁	A2 ₃	A2 ₅	A2 ₇
C	$\overline{\text{TRST}}$	CLKAB ₁	LEAB ₁	$\overline{\text{OEAB}}_1$	GND	CLKAB ₂	LEAB ₂	$\overline{\text{OEAB}}_2$
D	TMS	GND	V _{CC}	GND	V _{CC}	GND	TDI	TDO
E	TCK	GND	V _{CC}	V _{CC}	GND	GND	N/C	V _{CC}
F	CLKBA ₁	LEBA ₁	OEBA ₁	GND	N/C	CLKBA ₂	LEBA ₂	OEBA ₂
G	B1 ₁	B1 ₃	B1 ₅	B1 ₇	B2 ₁	B2 ₃	B2 ₅	B2 ₇
H	B1 ₀	B1 ₂	B1 ₄	B1 ₆	B2 ₀	B2 ₂	B2 ₄	B2 ₆

Connection Diagram

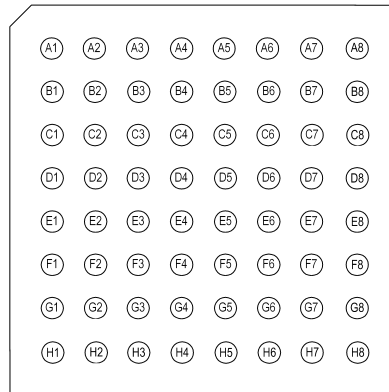

20051803

Top View

See NS Package Number SLC64A

www.datasheet4u.com

Truth Tables

Function Table for A to B Data Flow

Inputs				Outputs
OEAB	LEAB	CLKAB	A	B
L	L	L	X	B ₀ (Note 1)
L	L	↑	L	L
L	L	↑	H	H
L	H	X	L	L
L	H	X	H	H
H	X	X	X	Z

Function Table for B to A Data Flow

Inputs				Outputs
OEBA	LEBA	CLKBA	B	A
H	L	L	X	A ₀ (Note 1)
H	L	↑	L	L
H	L	↑	H	H
H	H	X	L	L
H	H	X	H	H
L	X	X	X	Z

H = HIGH Voltage Level

L = LOW Voltage Level

X = Immaterial (HIGH or LOW, inputs may not float)

Z = High Impedance

Note 1: Output level before the indicated steady-state input conditions were established.

Functional Description

In the normal mode, these devices are 16-bit universal bus transceivers that combine D-type latches and D-type flip-flops to allow data flow in transparent, latched, or clocked modes. They can be used as two 8-bit transceivers, or as one 16-bit transceiver. The test circuitry can be activated by the TAP to take snapshot samples of the data appearing at the device pins or to perform a self test on the boundary-test cells. Activating the TAP may affect the normal functional operation of the universal bus transceivers. When the TAP is activated, the test circuitry performs boundary-scan test operations according to the protocol described in IEEE Std 1149.1-1990.

Data flow in each direction is controlled by output-enable (OEAB and OEBA), latch-enable (LEAB and LEBA), and clock (CLKAB and CLKBA) inputs. For A-to-B data flow, the devices operate in the transparent mode when LEAB is high. When LEAB is low, the A data is latched while CLKAB is held at a static low or high logic level. Otherwise, if LEAB is low, A data is stored on a low-to-high transition of CLKAB. When OEAB is LOW, the B outputs are active. When OEAB is HIGH, the B outputs are in the high-impedance state. B-to-A data flow is similar to A-to-B data flow but uses the OEBA, LEBA, and CLKBA inputs. The output enables are complementary to facilitate the use of a single R/W signal without additional logic.

Five dedicated test pins are used to observe and control the operation of the test circuitry: test data input (TDI), test data output (TDO), test mode select (TMS), test clock (TCK), and test reset (TRST). All testing and scan operations are synchronized to the TAP interface.

For details about the sequence of boundary scan cells in the SCAN16602, please refer to the BSDL (Boundary Scan Description Language) file available on our website at <http://www.national.com/scan>.

Absolute Maximum Ratings (Note 2)

Supply Voltage (V_{CC})	-0.5V to +4.6V
DC Input Diode Current (I_{IK})	
$V_I = -0.5V$	-50 mA
DC Output Diode Current (I_{OK})	
$V_O = -0.5V$	-50 mA
DC Input Voltage (V_I)	-0.5V to 4.6V
DC Output Voltage (V_O)	-0.5V to 4.6V
DC Output Source/Sink Current (I_O)	± 50 mA
DC V_{CC} or Ground Current	
Per Supply Pin	± 100 mA
Junction Temperature	+150°C
Storage Temperature	-65°C to +150°C
Lead Temperature (Solder, 4sec)	
64L BGA	220 °C
Thermal Resistance	
BGA θ_{JA}	62°C/W

Package Derating

16.1mW/°C

above 25°C

ESD (Min)

2000V

Recommended Operating Conditions

Supply Voltage (V_{CC})	SCAN16602	2.7V to 3.6V
Input Voltage (V_I)		0V to 3.6V
Output Voltage (V_O)		0V to 3.6V
Operating Temperature (T_A)	Industrial	-40°C to +85°C

Note 2: Absolute maximum ratings are those values beyond which damage to the device may occur. The databook specifications should be met, without exception, to ensure that the system design is reliable over its power supply, temperature, and output/input loading variables. National does not recommend operation of SCAN circuits outside databook specifications.

DC Electrical Characteristics

Symbol	Parameter	V_{CC} (V)	Industrial		Units	Conditions
			$T_A = -40^\circ\text{C to } +85^\circ\text{C}$			
			Min	Max		
V_{IH}	Minimum High Input Voltage	2.7	2.0		V	$V_{OUT} = 0.1V$ or $V_{CC} - 0.1V$
		3.6	2.0			
V_{IL}	Maximum Low Input Voltage	2.7		0.8	V	$V_{OUT} = 0.1V$ or $V_{CC} - 0.1V$
		3.6		0.8		
V_{OH}	Minimum High Output Voltage All Outputs, All Options	2.7	2.5		V	$I_{OUT} = -100 \mu A$
		3.6	3.4			
		2.7	2.2			
	Minimum High Output Voltage TDO Outputs, All Options	3.0	2.2		V	$V_{IN} = V_{IL}$ or V_{IH} $I_{OH} = -24mA$
		2.7	2.2			
		3.0	2.2			
Minimum High Output Voltage A and B Ports: SCAN16602 and SCANH16602 options	2.7	2.2		V	$V_{IN} = V_{IL}$ or V_{IH} $I_{OH} = -12mA$	
	3.0	2.2				
Minimum High Output Voltage A and B Ports: SCAN162602 and SCANH162602 options (25 Ω series resistor options)	2.7	2.2		V	$V_{IN} = V_{IL}$ or V_{IH} $I_{OH} = -4mA$	
	3.0	2.2				
V_{OL}	Maximum Low Output Voltage All Outputs, All Options	2.7		0.2	V	$I_{OUT} = 100 \mu A$
		3.6		0.2		
	Maximum Low Output Voltage TDO Outputs, All Options	2.7		0.4	V	$V_{IN} = V_{IL}$ or V_{IH} $I_{OL} = 12mA$
		3.0		0.55		
Maximum Low Output Voltage A and B Ports: SCAN16602 and SCANH16602 Options	2.7		0.4	V	$V_{IN} = V_{IL}$ or V_{IH} $I_{OL} = 12mA$	
	3.0		0.55			

DC Electrical Characteristics (Continued)

Symbol	Parameter	V _{CC} (V)	Industrial		Units	Conditions
			T _A = -40°C to +85°C			
			Min	Max		
	Maximum Low Output Voltage A and B Ports: SCAN162602 and SCANH162602 Options (25Ω series resistor options)	2.7		0.4	V	V _{IN} = V _{IL} or V _{IH} , I _{OL} = 4mA
		3.0		0.6	V	V _{IN} = V _{IL} or V _{IH} , I _{OL} = 12mA
I _{IN}	Maximum Input Leakage Current	3.6		±5.0	μA	V _I = V _{CC} , GND
I _{ILR}	Input Low Current	3.6	-20	-250	μA	V _{IN} = GND
I _{OZ}	Maximum I/O Leakage Current	3.6		±10.0	μA	V _I (OE) = V _{IL} , V _{IH} V _I = V _{CC} , GND V _O = V _{CC} , GND
I _{I(HOLD)}	Bus Hold Input Minimum Drive Hold Current (Note 3)	2.7	±35		μA	V _I = 0.8V or 2.0V
		3.6		±500		V _I = 0 to 3.6V
V _{IKL}	Input Clamp Diode Voltage	2.7		-1.5	V	I _{IN} = -18mA
I _{OFF}	Power-off Leakage Current	0.0		±10.0	μA	V _O = V _{CC} , GND
I _{CC}	Maximum Quiescent Supply Current	3.6		20	μA	
I _{CCt}	Maximum I _{CC} Per Input	3.6		0.5	mA	V _I = V _{CC} -0.6V

Note 3: Applies to devices with Bus Hold feature only.

Noise Specifications

Applies to SCAN16602 and SCANH16602 options, C_L = 30pF, R_L = 500Ω to GND

Symbol	Parameter	V _{CC} (V)	Industrial		Units
			T _A = 25°C		
			Typical Limits		
V _{OLP}	Quiet Output Maximum Dynamic VOL (Note 4)	3.3		1.2	V
V _{OLV}	Quiet Output Minimum Dynamic VOL (Note 4)	3.3		-1.5	V
V _{OHP}	Quiet Output Maximum Dynamic VOH (Note 5)	3.3		VOH + 0.9	V
V _{OHV}	Quiet Output Minimum Dynamic VOH (Note 5)	3.3		VOH - 1.5	V

Noise Specifications

Applies to SCAN162602 and SCANH162602 options, $C_L = 30\text{pF}$, $R_L = 500\Omega$ to GND

Symbol	Parameter	V_{CC} (V)	Industrial	Units
			$T_A = 25^\circ\text{C}$	
			Typical Limits	
V_{OLP}	Quiet Output Maximum Dynamic VOL (Note 4)	3.3	0.5	V
V_{OLVM}	Quiet Output Minimum Dynamic VOL (Note 4)	3.3	-0.4	V
V_{OHP}	Quiet Output Maximum Dynamic VOH (Note 5)	3.3	$VOH + 0.5$	V
V_{OHV}	Quiet Output Minimum Dynamic VOH (Note 5)	3.3	$VOH - 0.5$	V

Note 4: Maximum number of outputs is defined as n. (n-1) outputs are switched LOW while the quiet output is monitored in a LOW (VOL) state. Also, (n-1) outputs are switched HIGH while the quiet output is monitored in a LOW (VOL) state.

Note 5: Maximum number of outputs is defined as n. (n-1) outputs are switched LOW while the quiet output is monitored in a HIGH (VOH) state. Also, (n-1) outputs are switched HIGH while the quiet output is monitored in a HIGH (VOH) state.

AC Electrical Characteristics

Normal Operation, over recommended operating supply voltage and temperature ranges unless otherwise specified.

Symbol	Parameter	SCAN16602, SCANH16602		Units
		$C_L = 30\text{ pF}$ $R_L = 500\Omega$ to GND		
		Min	Max	
t_{PLH} , t_{PHL}	Propagation Delay A to B, B to A		5.5	ns
t_{PLH} , t_{PHL}	Propagation Delay CLKAB to B, CLKBA to A		6.0	ns
t_{PLH} , t_{PHL}	Propagation Delay LEAB to B, LEBA to A		6.0	ns
t_{PLZ} , t_{PHZ}	Disable Time, \overline{OEAB} to B, OEBA to A		7.5	ns
t_{PZL} , t_{PZH}	Enable Time, \overline{OEAB} to B, OEBA to A		7.5	ns

AC Electrical Characteristics

Normal Operation, over recommended operating supply voltage and temperature ranges unless otherwise specified.

Symbol	Parameter	SCAN162602		Units
		$C_L = 30\text{ pF}$ $R_L = 500\Omega$ to GND		
		Min	Max	
t_{PLH} , t_{PHL}	Propagation Delay A to B, B to A		6.0	ns
t_{PLH} , t_{PHL}	Propagation Delay CLKAB to B, CLKBA to A		6.5	ns
t_{PLH} , t_{PHL}	Propagation Delay LEAB to B, LEBA to A		6.5	ns
t_{PLZ} , t_{PHZ}	Disable Time, \overline{OEAB} to B, OEBA to A		8.0	ns
t_{PZL} , t_{PZH}	Enable Time, \overline{OEAB} to B, OEBA to A		8.0	ns

AC Electrical Characteristics

Normal Operation, over recommended operating supply voltage and temperature ranges unless otherwise specified.

Symbol	Parameter	SCANH162602		Units
		$C_L = 30 \text{ pF}$ $R_L = 500\Omega \text{ to GND}$		
		Min	Max	
t_{PLH} , t_{PHL}	Propagation Delay A to B, B to A		6.0	ns
t_{PLH} , t_{PHL}	Propagation Delay CLKAB to B, CLKBA to A		6.5	ns
t_{PLH} , t_{PHL}	Propagation Delay LEAB to B, LEBA to A		6.5	ns
t_{PLZ} , t_{PHZ}	Disable Time, \overline{OEAB} to B, OEBA to A		8.0	ns
t_{PZL} , t_{PZH}	Enable Time, \overline{OEAB} to B, OEBA to A		8.0	ns

AC Operating Requirements

Normal Operation, over recommended operating supply voltage and temperature ranges unless otherwise specified

Symbol	Parameter	All Options	Units
		$T_A = -40^\circ\text{C to } +85^\circ\text{C}$ $C_L = 30 \text{ pF}$, $R_L = 500\Omega \text{ to GND}$	
		Guaranteed Minimum	
t_S	Setup Time, A to CLKAB or B to CLKBA	1.5	ns
t_H	Hold Time, A to CLKAB or B to CLKBA	2.0	ns
t_S	Setup Time, A to LEAB or B to LEBA	1.5	ns
t_H	Hold Time, A to LEAB or B to LEBA	2.5	ns
t_W	Pulse Width, CLKAB or CLKBA, high or low	2.0	ns
t_W	Pulse Width, LEAB or LEBA high	2.0	ns
f_{max}	Maximum CLKAB or CLKBA Clock Frequency	250	MHz

AC Operating Requirements

can Test Operation, over recommended operating supply voltage and temperature ranges unless otherwise specified

Symbol	Parameter	All Options	Units
		$T_A = -40^\circ\text{C to } +85^\circ\text{C}$ $C_L = 30 \text{ pF}$, $R_L = 500\Omega \text{ to GND}$	
		Guaranteed Minimum	
t_S	Setup Time, H or L, TMS to TCK	2.0	ns
t_H	Hold Time, H or L, TCK to TMS	1.0	ns
t_S	Setup Time, H or L, TDI to TCK	1.0	ns
t_H	Hold Time, H or L, TCK to TDI	2.0	ns
t_W	Pulse Width TCK High or Low	10	ns
t_W	Pulse Width \overline{TRST} , Low	2.5	ns
f_{max}	Maximum TCK Clock Frequency	25	MHz
t_{REC}	Recovery Time, \overline{TRST} to TCK	2.0	ns

Capacitance and I/O Characteristics

Refer to National's website for IBIS models at <http://www.national.com/scan>

Device ID Register

Ordering Code	Features	Device ID	Manufacturer & LSB
SCAN16602SM	No bus hold, no series resistor	FC30	01F
SCANH16602SM	With bus hold only	FC31	01F
SCAN162602SM	With 25 Ω series resistors in outputs	FC32	01F
SCANH162602SM	With 25 Ω series resistors and bus hold	FC33	01F

Physical Dimensions inches (millimeters) unless otherwise noted

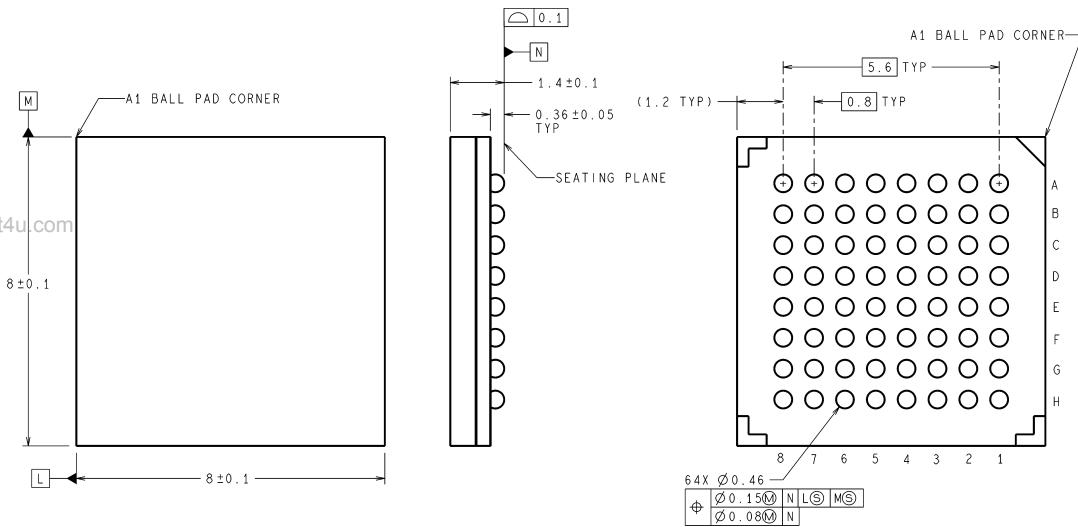

DIMENSIONS ARE IN MILLIMETERS

SLC64A (Rev C)

64-Lead Ball Grid Array Package
Order Number SCAN16602SM,
SCANH16602SM, SCAN162602SM, SCANH162602SM
NS Package Number SLC64A

LIFE SUPPORT POLICY

NATIONAL'S PRODUCTS ARE NOT AUTHORIZED FOR USE AS CRITICAL COMPONENTS IN LIFE SUPPORT DEVICES OR SYSTEMS WITHOUT THE EXPRESS WRITTEN APPROVAL OF THE PRESIDENT AND GENERAL COUNSEL OF NATIONAL SEMICONDUCTOR CORPORATION. As used herein:

1. Life support devices or systems are devices or systems which, (a) are intended for surgical implant into the body, or (b) support or sustain life, and whose failure to perform when properly used in accordance with instructions for use provided in the labeling, can be reasonably expected to result in a significant injury to the user.
2. A critical component is any component of a life support device or system whose failure to perform can be reasonably expected to cause the failure of the life support device or system, or to affect its safety or effectiveness.



National Semiconductor
Americas Customer
Support Center
 Email: new.feedback@nsc.com
 Tel: 1-800-272-9959

National Semiconductor
Europe Customer Support Center
 Fax: +49 (0) 180-530 85 86
 Email: europe.support@nsc.com
 Deutsch Tel: +49 (0) 69 9508 6208
 English Tel: +44 (0) 870 24 0 2171
 Français Tel: +33 (0) 1 41 91 8790

National Semiconductor
Asia Pacific Customer
Support Center
 Email: ap.support@nsc.com

National Semiconductor
Japan Customer Support Center
 Fax: 81-3-5639-7507
 Email: jpn.feedback@nsc.com
 Tel: 81-3-5639-7560

www.national.com