

SIEMENS

STANDARD RED SCF5740 HIGH EFFICIENCY RED SCF5742 HIGH EFFICIENCY GREEN SCF5744

0.270" 4-Character, 5x7 Dot Matrix Serial Input Dot Addressable Intelligent Display™

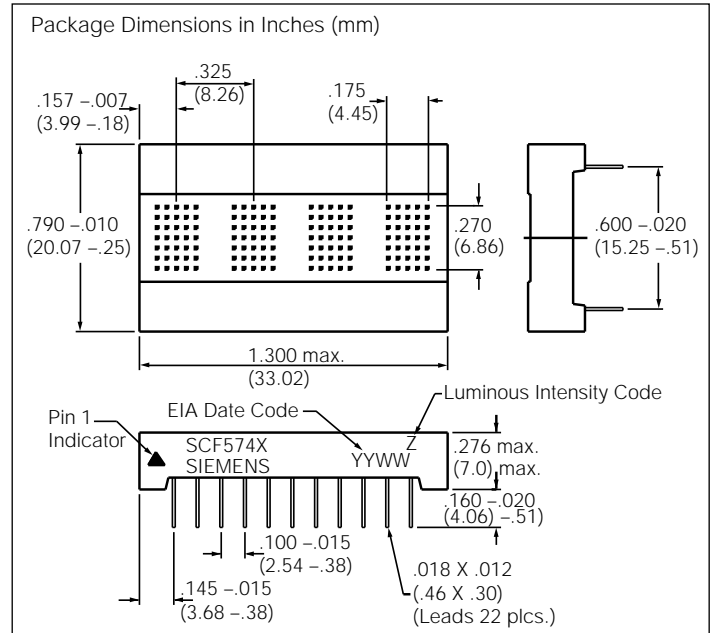
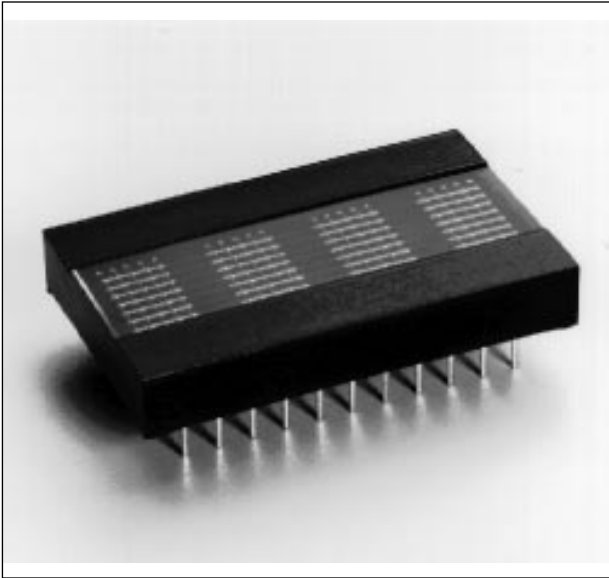

FEATURES

- Four 0.270" (6.85 mm) 5 x 7 Dot Matrix Characters in Red, High Efficiency Red, High Efficiency Green
- Optimum Display Surface Efficiency (display area to package ratio)
- High Speed Data Input Rate: 5 MHz
- ROMless Serial Input, Dot Addressable Display Ideal for User Defined Characters
- Built-in Decoders, Multiplexers and LED Drivers
- Readable from 6 Feet (1.8 meters)
- Wide Viewing Angle, X Axis $\pm 55^\circ$, Y Axis $\pm 55^\circ$
- Attributes
 - 140 Bit RAM for User Defined Characters
 - Eight Dimming Levels
 - Power Down Model ($<250 \mu W$)
 - Hardware/Software Clear Functions
 - Internal or External Clock

DESCRIPTION

The SCF574X is a four digit, dot addressable 5x7 dot matrix, serial input, alphanumeric Intelligent Display. The four digits are packaged in a rugged, high quality, optically transparent, plastic 22 pin DIP with 0.1" pin spacing.

The on-board CMOS has a 140 bit RAM, one bit associated with one LED, each to generate User Defined Characters. In Power Down Mode, quiescent current is $<50 \mu A$.

The SCF574X is designed for work with the serial port of most common microprocessors. Data is transferred into the display through the Serial Data Input (DATA), clocked by the Serial Data Clock (SDCLK), and enabled by the Load Input (LOAD).

The Clock I/O (CLK I/O) and Clock Select (CLK SEL) pins offer the user the capability to supply a high speed external multiplex clock. This feature can minimize audio in-band interference for portable communication equipment or eliminate the visual synchronization effects found in high vibration environments such as avionic equipment.

Maximum Rating

DC Supply Voltage -0.5 to +7.0 Vdc
 Input Voltage Levels Relative to Ground -0.5 to $V_{CC}+0.5$ Vdc
 Operating Temperature -40°C to +85°C
 Storage Temperature -40°C to +100°C
 Maximum Solder Temperature 0.063" below Seating Plane, $t < 5$ sec 260°C
 Relative Humidity at 85°C 85%
 Maximum Number of LEDs at 100% Brightness 64
 Maximum Power Dissipation 0.65 W
 ESD (100 pF, 1.5 K Ω) 2 KV
 Maximum Input Current ± 186 mA

Switching Specifications

(over operating temperature range and $V_{CC}=4.5$ V to 5.5 V)

Symbol	Description	Min.	Units
T_{RC}	Reset Active Time	600	ns
T_{LDS}	Load Setup Time	50	ns
T_{DS}	Data Setup Time	50	ns
T_{SDCLK}	Clock Period	200	ns
T_{SDCW}	Clock Width	70	ns
T_{LDH}	Load Hold Time	0	ns
T_{DH}	Data Hold Time	25	ns
T_{WR}	Total Write Time	2.2	μ s
T_{BL}	Time Between Loads	600	ns

Note:

T_{SDCW} is the minimum time the SDCLK may be low or high. The SDCLK period must be a minimum of 200 ns.

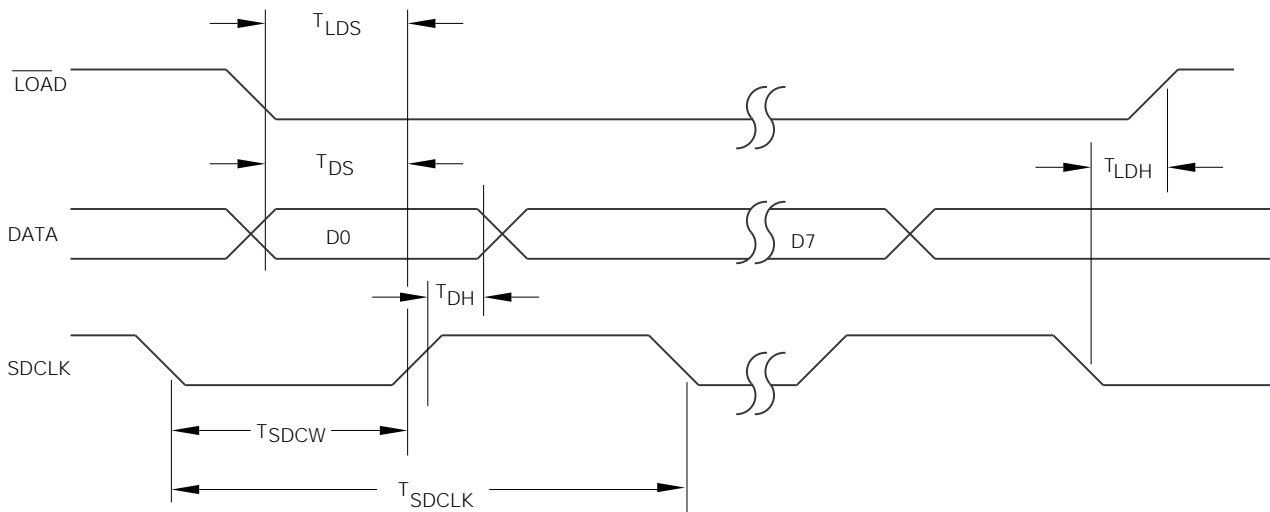

Figure 1. Timing diagram—Data write cycle

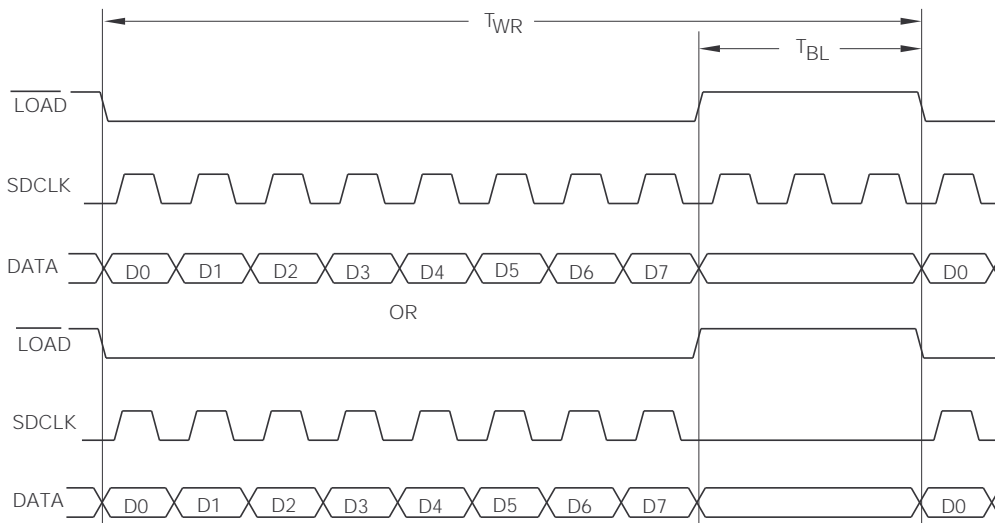

Figure 2. Timing diagram—Instruction cycle

Electrical Characteristics (over Operating Temperature)

Parameter	Min.	Typ.	Max.	Units	Conditions
V_{CC}	4.5	5.0	5.5	V	
I_{CC} (Pwr Dwn Mode) ⁽⁴⁾			50	μ A	$V_{CC}=5$ V, all inputs=0 V or V_{CC}
I_{CC} 4 digits 20 dots/character		150	186	mA	$V_{CC}=5$ V, “#” displayed in all 4 digits at 100% brightness at 25°C
I_{IL} Input current			-10	μ A	$V_{CC}=5$ V, $V_{IN}=0$ V (all inputs)
I_{IH} Input current			+10	μ A	$V_{CC}=V_{IN}=5.0$ V=0 V (all inputs)
V_{IH}	3.5			V	$V_{CC}=4.5$ V to 5.5 V
V_{IL}			1.5	V	$V_{CC}=4.5$ V to 5.5 V
I_{OH} (CLK I/O)		-28		mA	$V_{CC}=4.5$ V, $V_{OH}=2.4$ V
I_{OL} (CLK I/O)		23		mA	$V_{CC}=4.5$ V, $V_{OL}=0.4$ V
θ_{JC-PIN}			32	°C/W	
F_{ext} External Clock Input Frequency	120		347	KHz	$V_{CC}=5.0$ V, $\overline{CLKSEL}=0$
F_{osc} Internal Clock Input Frequency	120		347	KHz	$V_{CC}=5.0$ V, $\overline{CLKSEL}=1$
Clock I/O Bus Loading			240	pF	
Clock Out Rise Time			500	ns	$V_{CC}=4.5$ V, $V_{OH}=2.4$ V
Clock Out Fall Time			500	ns	$V_{CC}=4.5$ V, $V_{OH}=0.4$ V
FM, Digit	375	768	1086	Hz	

Notes

1. Peak current $\frac{5}{3} \times I_{CC}$.
2. Unused inputs must be tied high.
3. Contact Siemens for 3.3 volt operation.
4. External oscillator must be stopped if being used to maintain an $I_{CC} < 50\mu$ A.

Input/Output Circuits

Figures 3 and 4 show the input and output resistor/diode networks used for ESD protection and to eliminate substrate latch-up caused by input voltage over/under shoot.

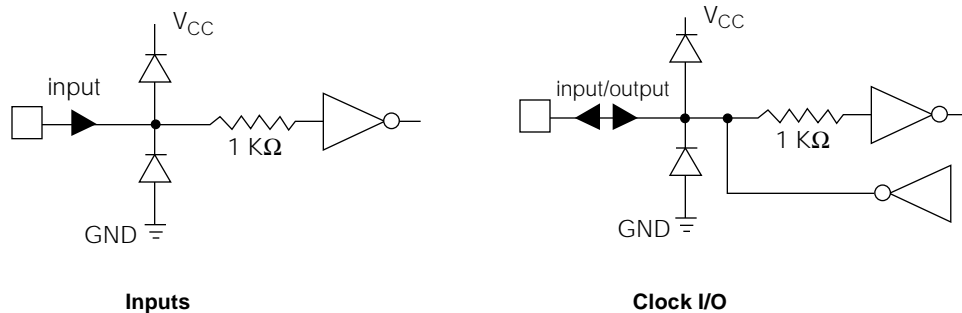

Figures 3 and 4.

Optical Characteristics at 25°C

$V_{CC}=5.0$ V at 100% Brightness Level, Viewing Angle: X Axis $\pm 55^\circ$, Y Axis $\pm 65^\circ$

Red SCF5740

Description	Symbol	Min.	Typ.	Units
Luminous Intensity per dot	I_V	55		$\mu\text{cd}/\text{dot}$
Peak Wavelength	$\lambda(\text{peak})$		655	nm
Dominant Wavelength	$\lambda(\text{d})$		639	nm

High Efficiency Red SCF5742

Description	Symbol	Min.	Typ.	Units
Luminous Intensity per dot	I_V	110		$\mu\text{cd}/\text{dot}$
Peak Wavelength	$\lambda(\text{peak})$		630	nm
Dominant Wavelength	$\lambda(\text{d})$		626	nm

High Efficiency Green SCF5744

Description	Symbol	Min.	Typ.	Units
Luminous Intensity per dot	I_V	110		$\mu\text{cd}/\text{dot}$
Peak Wavelength	$\lambda(\text{peak})$		568	nm
Dominant Wavelength	$\lambda(\text{d})$		574	nm

Notes

1. Dot to dot intensity matching at 100% brightness is 1.8:1.
2. Displays within a given intensity category have an intensity matching of 1.5:1 (max.)

Top View

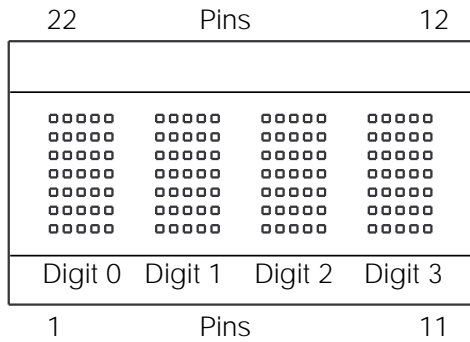

Pin Assignment

Pin	Function	Pin	Function
1	N/C	22	N/C
2	GND	21	CLKSEL
3	N/C	20	CLK I/O
4	N/C	19	$\overline{\text{RST}}$
5	N/C	18	N/C
6	N/C	17	N/C
7	N/C	16	N/C
8	N/C	15	SCLK
9	V _{LL}	14	DATA
10	V _{CC}	13	$\overline{\text{LOAD}}$
11	N/C	12	N/C

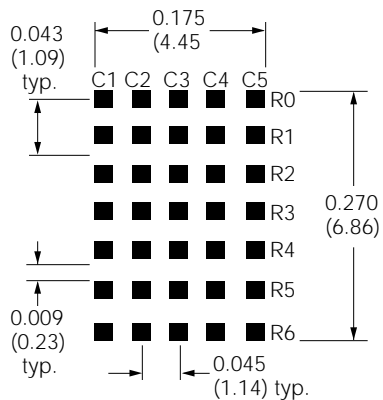

Dimensions in inches (mm)
Tolerance: .XXX ± .010 (.25)

Figure 5. Dot Matrix Format

Pin Definitions

Pin	Function	Definitions
1	N/C	
2	GND	Power supply ground
3	N/C	
4	N/C	
5	N/C	
6	N/C	
7	N/C	
8	N/C	
9	V _{LL}	LED supply
10	V _{CC}	Logic supply
11	N/C	
12	N/C	
13	$\overline{\text{LOAD}}$	Low input enables data clocking into 8-bit serial shift register. When load goes high, the contents of 8-bit serial shift register will be decoded.
14	DATA	Serial data input
15	SDCLK	For loading data into the 8-bit serial data register
16	N/C	
17	N/C	
18	N/C	
19	$\overline{\text{RST}}$	Asynchronous input, when low clears the multiplex counter, address register, control word register, user RAM and data register. Control word register is set to 100% brightness. The display will be blank.
20	CLK I/O	Outputs Master Clock or inputs External Clock
21	CLKSEL	High=Internal Clock (Master) Low=External Clock (Slave)
22	N/C	

Display Column and Row Format

	C 0	C 1	C 2	C 3	C 4
Row 0	1	1	1	1	1
Row 1	0	0	1	0	0
Row 2	0	0	1	0	0
Row 3	0	0	1	0	0
Row 4	0	0	1	0	0
Row 5	0	0	1	0	0
Row 6	0	0	1	0	0

1=Display dot "On"
0=Display dot "Off"

Column Data Ranges

Row 0	00H to 1FH
Row 1	00H to LFH
Row 2	00H to LFH
Row 3	00H to LFH
Row 4	00H to LFH
Row 5	00H to LFH
Row 6	00H to LFH

Operation of the SCF574X

The SCF574X display consists of a CMOS IC containing control logic and drivers for four 5x7 characters. These components are assembled in a compact plastic package.

Individual LED dot addressability allows the user great freedom in creating special characters or mini-icons.

The serial data interface provides a highly efficient interconnection between the display and the mother board. The SCF574X requires only three lines as compared to 14 for an equivalent four character parallel input part.

The on-board CMOS IC is the electronic heart of the display. The IC accepts decoded serial data, which is stored in the internal RAM. Asynchronously the RAM is read by the character multiplexer at a strobe rate that results in a flicker free display. Figure 6 shows the three functional areas of the IC. These include: the input serial data register and control logic, a 140 bits two port RAM, and an internal multiplexer/display driver.

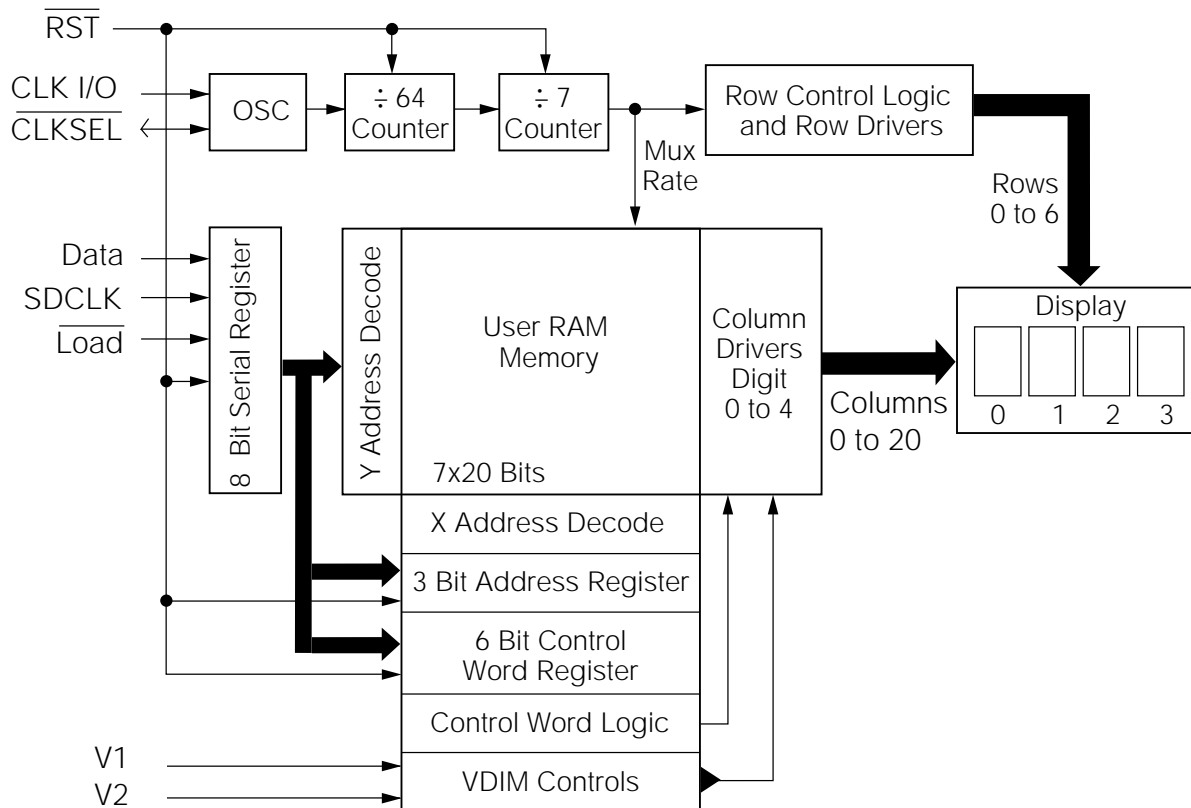

Figure 6. Block Diagram

The following explains how to format the serial data to be loaded into the display. The user supplies a string of bit mapped decoded characters. The contents of this string is shown in Figure 7a. Figure 7b shows that each character consist of eight 8 bit words. The first word encodes the display character location and the succeeding seven bytes are row data. The row data represents the status (On, Off) of individual column LEDs. Figure 7c shows that each 8 bit word is formatted to represent Character Address, or Column Data.

Figure 7d shows the sequence for loading the bytes of data. Bringing the $\overline{\text{LOAD}}$ line low enables the serial register to accept data. The shift action occurs on the low to high transition of the serial data clock (SDCLK). The least significant bit (D0) is loaded first. After eight clock pulses the $\overline{\text{LOAD}}$ line is brought high. With this transition the OPCODE is decoded. The decoded OPCODE directs D4–D0 to be latched in the Character Address register, stored in the RAM as Column data, or latched in the Control Word register. The control IC requires a minimum 600 ns delay between successive byte loads. As indicated in Figure 7a, a total of 256 bits of data are required to load all four characters into the display.

The Character Address Register bits, D4–D0 (Table 2), and Row Address Register bits, D7–D5 (Table 3), direct the Column Data bits, D4–D0 (Table 3) to specific RAM location.

Table 7 shows the Row Address for the example character "D." Column data is written and read asynchronously from the 140 bit RAM. Once loaded the internal oscillator and character multiplexer reads the data from the RAM. These characters are row strobed with column data as shown in Figures 8 and 9. The character strobe rate is determined by the internal or user supplied external MUX Clock and the IC's $\div 320$ counter.

Table 7. Character "D"

	Op code D7 D6 D5	Column Data D4 D3 D2 D1 D0 C0 C1 C2 C3 C4	Hex
Row 0	0 0 0	1 1 1 1 0	1E
Row 1	0 0 0	1 0 0 0 1	11
Row 2	0 0 0	1 0 0 0 1	11
Row 3	0 0 0	1 0 0 0 1	11
Row 4	0 0 0	1 0 0 0 1	11
Row 5	0 0 0	1 0 0 0 1	11
Row 6	0 0 0	1 1 1 1 0	1E

Example: Serial Clock = 5MHz, Clock Period = 200ns

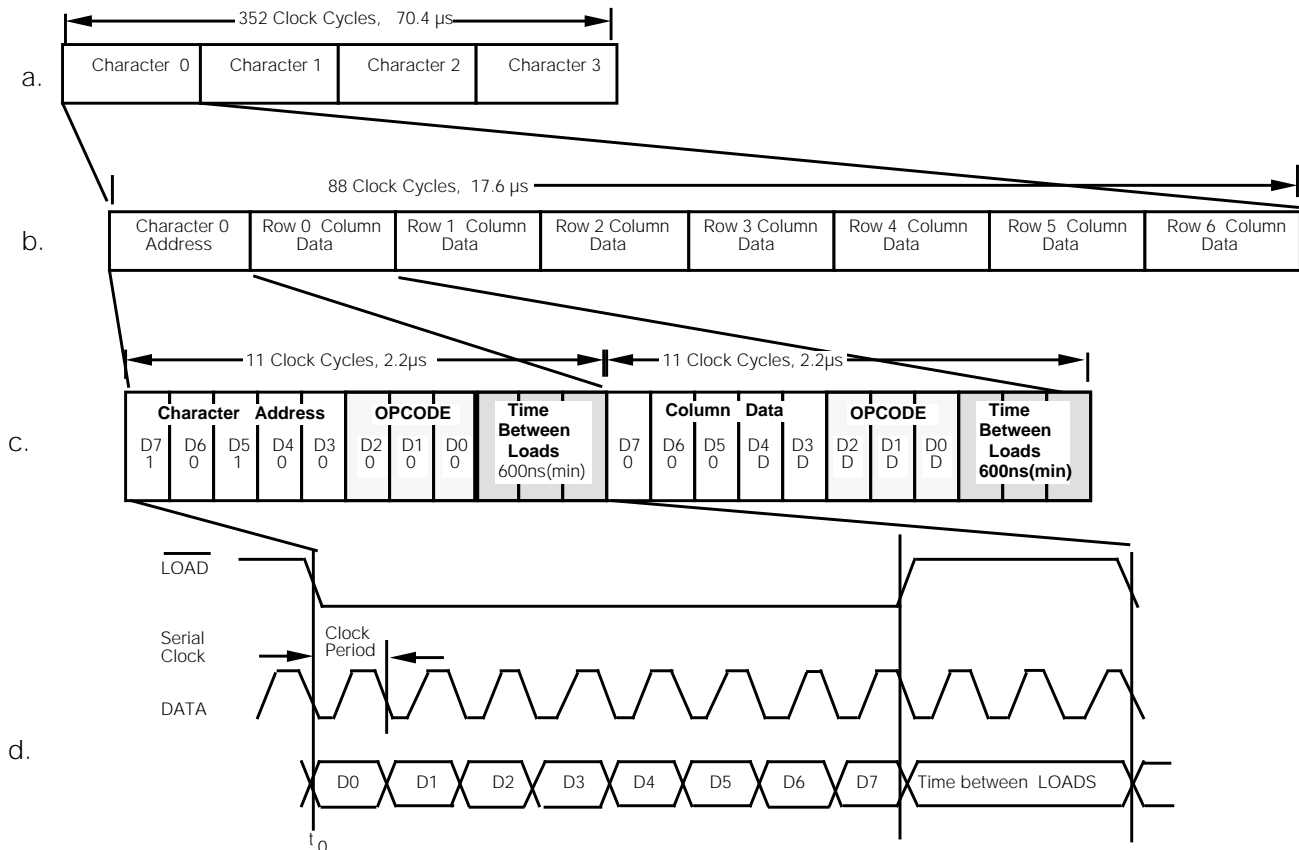

Figure 7a–d. Loading Serial Character Data

The user can activate four Control functions. These include: LED Brightness Level, IC Power Down, Prescaler, or Display Clear. OPCODEs and six bit words are used to initiate these functions. The OPCODEs and Control Words for the Character Address and Loading Column Data are shown in Tables 2 and 3.

Table 2. Load Character Address

Op code D7 D6 D5	Character Address D4 D3 D2 D1 D0	Hex	Operation Load
1 0 1	0 0 0 0 0	A0	Character 0
1 0 1	0 0 0 0 1	A1	Character 1
1 0 1	0 0 0 1 0	A2	Character 2
1 0 1	0 0 0 1 1	A3	Character 3

Table 3. Load Column Data

Op code D7 D6 D5	Column Data D4 D3 D2 D1 D0	Operation Load
0 0 0	C0 C1 C2 C3 C4	Row 0
0 0 0	C0 C1 C2 C3 C4	Row 1
0 0 0	C0 C1 C2 C3 C4	Row 2
0 0 0	C0 C1 C2 C3 C4	Row 3
0 0 0	C0 C1 C2 C3 C4	Row 4
0 0 0	C0 C1 C2 C3 C4	Row 5
0 0 0	C0 C1 C2 C3 C4	Row 6

The user can select eight specific LED brightness levels, Table 4. Depending on how D3 is selected either one (1) for maximum peak current or zero (0) for 12.5% of maximum peak current in the control word per Table 4a and 4b, the user can select 16 specific LED brightness levels. These brightness levels (in percentages of full brightness of the display) depending on how the user selects D3 can be one (1) or zero (0) are as follows: 100% (E0_{HEX} or E8_{HEX}), 53% (E1_{HEX} or E9_{HEX}), 40% (E2_{HEX} or EA_{HEX}), 27% (E3_{HEX} or EB_{HEX}), 20% (E4_{HEX} or EC_{HEX}), 13% (E5_{HEX} or ED_{HEX}), and 6.6% (E6_{HEX} or EE_{HEX}), 0.0% (E7_{HEX} or EF_{HEX}). The brightness levels are controlled by changing the duty factor of the row strobe pulse.

Table 4a. Display Brightness

Op code D7 D6	Control Word D5 D4 D3 D2 D1 D0	Hex	Operation Level
1 1	1 0 0 0 0 0	E0	100%
1 1	1 0 0 0 0 1	E1	53%
1 1	1 0 0 0 1 0	E2	40%
1 1	1 0 0 0 1 1	E3	27%
1 1	1 0 0 1 0 0	E4	20%
1 1	1 0 0 1 0 1	E5	13%
1 1	1 0 0 1 1 0	E6	6.6%
1 1	1 0 0 1 1 1	E7	0.0%

Table 4b. Display Brightness

Op code D7 D6	Control Word D5 D4 D3 D2 D1 D0	Hex	Operation Level
1 1	1 0 1 0 0 0	E0	100%
1 1	1 0 1 0 0 1	E1	53%
1 1	1 0 1 0 1 0	E2	40%
1 1	1 0 1 0 1 1	E3	27%
1 1	1 0 1 1 0 0	E4	20%
1 1	1 0 1 1 0 1	E5	13%
1 1	1 0 1 1 1 0	E6	6.6%
1 1	1 0 1 1 1 1	E7	0.0%

The SCF574X offers a unique Display Power Down feature which reduces ICC to less than 50 μ A. When EF_{HEX} is loaded (Table 5) the display is set to 0% brightness. When in the Power Down mode data may still be written into the RAM. The display is reactivated by loading a new brightness Level Control Word into the display.

Table 5. Power Down

Op code D7 D6	Control Word D5 D4 D3 D2 D1 D0	Hex	Operation Level
1 1	1 0 1 1 1 1	EF	0% brightness

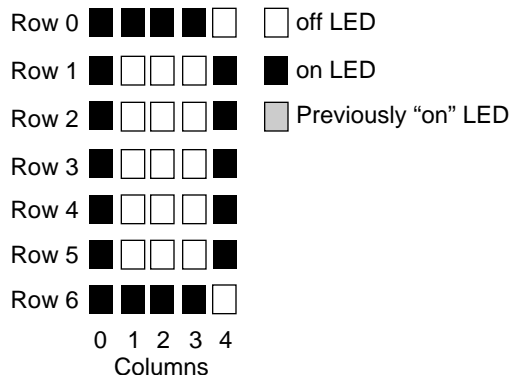

Figure 8. Row and Column Locations for a Character "D"

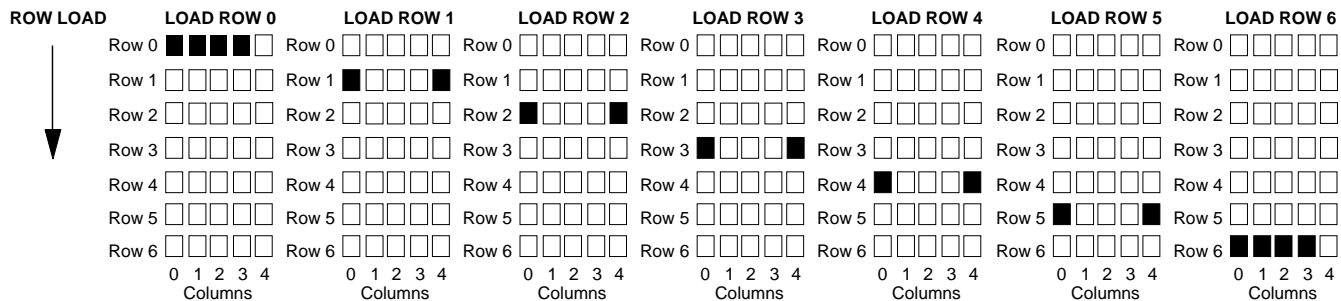

Figure 9. Row Strobing

The SCF574X allows a high frequency external oscillator source to drive the display. Data bit, D4, in the control word format controls the prescaler function. The prescaler allows the oscillator source to be divided by 16 by setting D4=1. However, the prescaler should not be used, i.e., when using the internal oscillator source.

The Software Clear (C0_{HEX}), given in Table 6, clears the Address Register and the RAM. The display is blanked and the Character Address Register will be set to Character 0. The internal counter and the Control Word Register are unaffected. The Software Clear will remain active until the next data input cycle is initiated.

Table 6. Software Clear

Op code D7 D6	Control Word D5 D4 D3 D2 D1 D0	Hex	Operation
1 1	0 0 0 0 0 0	C0	CLEAR

Multiplexer and Display Driver

The four characters are row multiplexed with RAM resident column data. The strobe rate is established by the internal or external MUX Clock rate. The MUX Clock frequency is divided by a 448 counter chain. This results in a typical strobe rate of 768 Hz. By pulling the Clock SEL line low, the display can be operated from an external MUX Clock. The external clock is attached to the CLK I/O connection (pin 9). The maximum external MUX Clock frequency should be limited to 1 MHz.

An asynchronous hardware Reset (pin 8) is also provided. Bringing this pin low will clear the Character Address Register, Control Word Register, RAM, and blanks the display. This action leaves the display set at Character Address 0, and the Brightness Level set at 100%.

ELECTRICAL & MECHANICAL CONSIDERATIONS

Interconnect Considerations

Optimum product performance can be had when the following electrical and mechanical recommendations are adopted. The SCF574X's IC is constructed in a high speed CMOS process, consequently high speed noise on the SERIAL DATA, SERIAL DATA CLOCK, LOAD and RESET lines may cause incorrect data to be written into the serial shift register. Adhere to transmission line termination procedures when using fast line drivers and long cables (>10 cm).

Good ground (pin 2) and power supply decoupling (pins 9 and 10) will insure that I_{CC} (<400 mA peak) switching currents do not generate localized ground bounce. Therefore it is recommended that each display package use a 0.1µF and 20µF capacitor between V_{CC} and ground.

When the internal MUX Clock is being used connect the $\overline{\text{CLK-SEL}}$ pin to V_{CC}. In those applications where RESET will not be connected to the system's reset control, it is recommended that this pin be connected to the center node of a series 0.1, µF and 100 KΩ RC network. Thus upon initial power up the RESET will be held low for 10 ms allowing adequate time for the system power supply to stabilize.

ESD Protection

The input protection structure of the SCF574X provides significant protection against ESD damage. It is capable of withstanding discharges greater than 2 kV. Take all the standard precautions, normal for CMOS components. These include properly grounding personnel, tools, tables, and transport carriers that come in contact with unshielded parts. If these conditions are not, or cannot be met, keep the leads of the device shorted together or the parts in anti-static packaging.

Soldering Considerations

The SCF574X can be hand soldered with SN63 solder using a grounded iron set to 260°C.

Wave soldering is also possible following these conditions: Preheat that does not exceed 93°C on the solder side of the PC board or a package surface temperature of 85°C. Water soluble organic acid flux (except carboxylic acid) or resin-based RMA flux without alcohol can be used.

Wave temperature of 245°C ±5°C with a dwell between 1.5 sec. to 3.0 sec. Exposure to the wave should not exceed temperatures above 260°C for five seconds at 0.063" below the seating plane. The packages should not be immersed in the wave.

Post Solder Cleaning Procedures

The least offensive cleaning solution is hot D.I. water (60°C) for less than 15 minutes. Addition of mild saponifers is acceptable. Do not use commercial dishwasher detergents.

For faster cleaning, solvents may be used. Exercise care in choosing solvents as some may chemically attack the nylon package. For further information refer to Appnotes 18 and 19 in the current Siemens Optoelectronic Data Book. See Appnote 19, Table 1, "Displays-Group 2" for the SCDV554X.

An alternative to soldering and cleaning the display modules is to use sockets. Naturally, 14 pin DIP sockets .300" wide with .100" centers work well for single displays. Multiple display assemblies are best handled by longer SIP sockets or DIP sockets when available for uniform package alignment. Socket manufacturers are Aries Electronics, Inc., Frenchtown, NJ; Garry Manufacturing, New Brunswick, NJ; Robinson-Nugent, New Albany, IN; and Samtec Electronic Hardware, New Albany, IN.

For further information refer to Appnote 22 in the current Siemens Optoelectronic Data Book.

Optical Considerations

The 0.270" high character of the SCF574X gives readability up to five feet. Proper filter selection enhances readability over this distance.

Using filters emphasizes the contrast ratio between a lit LED and the character background. This will increase the discrimination of different characters. The only limitation is cost. Take into consideration the ambient lighting environment for the best cost/benefit ratio for filters.

Incandescent (with almost no green) or fluorescent (with almost no red) lights do not have the flat spectral response of sunlight. Plastic band-pass filters are an inexpensive and effective way to strengthen contrast ratios. The SCF5740 is a red display and should be used with long wavelength pass filter having a sharp cut-off in the 600 nm to 620 nm range. The SCF5742 is a high efficiency red display and should be used with long wavelength pass filter having a sharp cut-off

in the 570 nm to 600 nm range. The SCF5744 is a high efficiency green display and should be used with long wavelength pass filter that peaks at 565 nm.

Additional contrast enhancement is gained by shading the displays. Plastic band-pass filters with built-in louvers offer the next step up in contrast improvement. Plastic filters can be improved further with anti-reflective coatings to reduce glare. The trade-off is fuzzy characters. Mounting the filters close to the display reduces this effect. Take care not to overheat the plastic filter by allowing for proper air flow.

Optimal filter enhancements are gained by using circular polarized, anti-reflective, band-pass filters. The circular polarizing further enhances contrast by reducing the light that travels through the filter and reflects back off the display to less than 1%.

Several filter manufacturers supply quality filter materials. Some of them are: Panelgraphic Corporation, W. Caldwell, NJ; SGL Homalite, Wilmington, DE; 3M Company, Visual Products Division, St. Paul, MN; Polaroid Corporation, Polarizer Division, Cambridge, MA; Marks Polarized Corporation, Deer Park, NY; Hoya Optics, Inc., Fremont, CA.

One last note on mounting filters: recessing displays and bezel assemblies is an inexpensive way to provide a shading effect in overhead lighting situations. Several Bezel manufacturers are: R.M.F. Products, Batavia, IL; Nobex Components, Griffith Plastic Corp., Burlingame, CA; Photo Chemical Products of California, Santa Monica, CA; I.E.E.-Atlas, Van Nuys, CA.

Microprocessor Interface

The microprocessor interface is through the serial port, SPI port or one out of eight data bits on the eight bit parallel port and also control lines \overline{SDCLK} and \overline{LOAD} .

Power Up Sequence

Upon power up display will come on at random. Thus the display should be reset at power-up. The reset will set the Address Register to Digit 0, User RAM is set to 0 (display blank) the Control Word is set to 0 (100% brightness) and the internal counters are reset

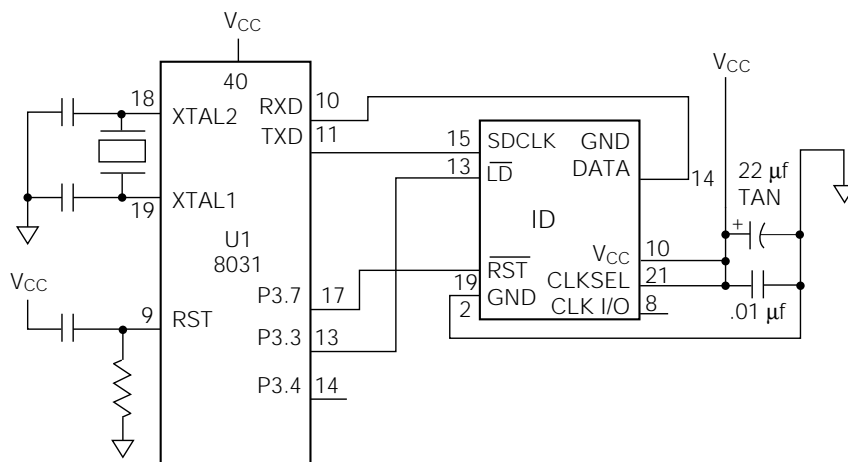

Figure 10. Display Interface to Siemens/Intel 8031 Microprocessor (using serial port in mode 0)

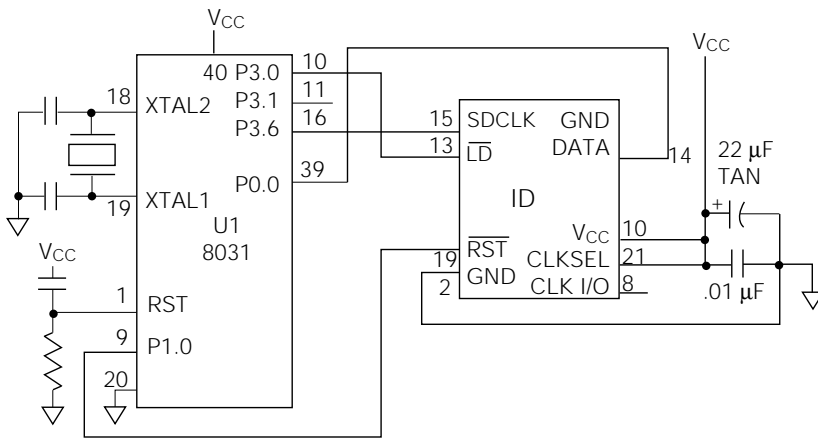

Figure 11. Display Interface to Siemens/Intel 8031 Microprocessor (using one bit of parallel port as serial port)

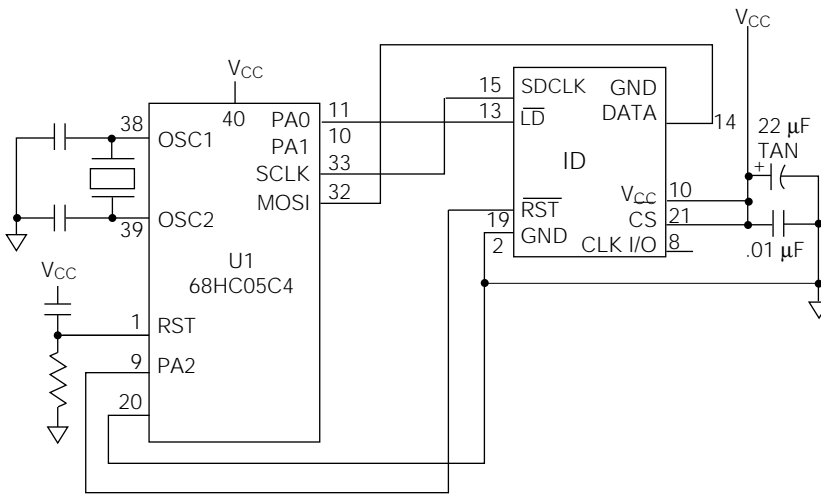

Figure 12. Display Interface with Motorola 68HC05C4 Microprocessor (using SPI Port)

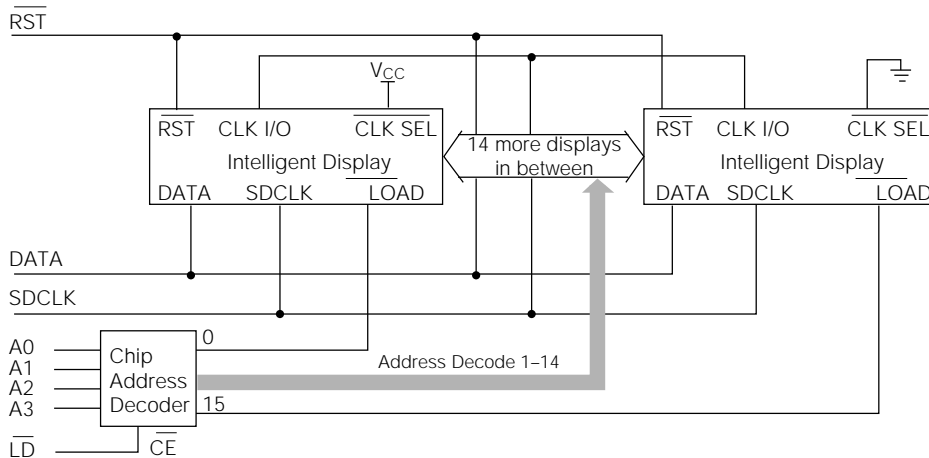

Figure 13. Cascading Multiple Displays

Multiple displays can be cascaded using the CLK SEL and CLK I/O pins (Figure 13). The display designated as the Master-Clock source should have its CLK SEL pin tied high and the slaves should have their CLK SEL pins tied low. All CLK I/O pins should be tied together. One display CLK I/O can drive 15 slave CLK I/Os. Use RST to synchronize all display counters.

Loading Data into the Display

Use following procedure to load data into the display:

1. Power up the display.
2. Bring \overline{RST} low (600 ns duration minimum) to clear the Multiplex Counter, Address Register, Control Word Register, User Ram and Data Register. The display will be blank. Display brightness is set to 100%.
3. If a different brightness is desired, load the proper brightness opcode into the Control Word Register.
4. Load the Digit Address into the display.
5. Load display row and column data for the selected digit.
6. Repeat steps 4 and 5 for all digits.

Data Contents for the Word "ABCD"

Step	D 7	D 6	D 5	D 4	D 3	D 2	D 1	D 0	Function
A B (optional)	1 1	1 1	0 1	0 0	0 0	0 0	0 0	0 0	CLEAR 100% BRIGHTNESS
1	1	0	1	0	0	0	0	0	DIGIT D0 SELECT
2	0	0	0	0	0	1	0	0	ROW 0 (A)
3	0	0	0	0	1	0	1	0	ROW 1 (A)
4	0	0	0	1	0	0	0	1	ROW 2 (A)
5	0	0	0	1	1	1	1	1	ROW 3 (A)
6	0	0	0	1	0	0	0	1	ROW 4 (A)
7	0	0	0	1	0	0	0	1	ROW 5 (A)
8	0	0	0	1	0	0	0	1	ROW 6 (A)
9	1	0	1	0	0	0	0	1	DIGIT D1 SELECT
10	0	0	0	1	1	1	1	1	ROW 0 (B)
11	0	0	0	1	0	0	0	1	ROW 1 (B)
12	0	0	0	1	0	0	0	1	ROW 2 (B)
13	0	0	0	1	1	1	1	0	ROW 3 (B)
14	0	0	0	1	0	0	0	1	ROW 4 (B)
15	0	0	0	1	0	0	0	1	ROW 5 (B)
16	0	0	0	1	1	1	1	1	ROW 6 (B)
17	1	0	1	0	0	0	1	0	DIGIT D2 SELECT
18	0	0	0	0	0	1	1	1	ROW 0 (C)
19	0	0	0	0	1	0	0	0	ROW 1 (C)
20	0	0	0	1	0	0	0	0	ROW 2 (C)
21	0	0	0	1	0	0	0	0	ROW 3 (C)
22	0	0	0	1	0	0	0	0	ROW 4 (C)
23	0	0	0	0	1	0	0	0	ROW 5 (C)
24	0	0	0	0	0	1	1	1	ROW 6 (C)
25	1	0	1	0	0	0	1	1	DIGIT D3 SELECT
26	0	0	0	1	1	1	1	0	ROW 0 (D)
27	0	0	0	1	0	0	0	1	ROW 1 (D)
28	0	0	0	1	0	0	0	1	ROW 2 (D)
29	0	0	0	1	0	0	0	1	ROW 3 (D)
30	0	0	0	1	0	0	0	1	ROW 4 (D)
31	0	0	0	1	0	0	0	1	ROW 5 (D)
32	0	0	0	1	1	1	1	0	ROW 6 (D)