

SCG2000i Synchronous Clock Generators

**CONNOR
WINFIELD**



PLL

2111 Comprehensive Drive
Aurora, Illinois 60505
Phone: 630-851-4722
Fax: 630-851-5040
www.conwin.com



Application

The Connor-Winfield SCG2000i provides high precision phase lock loop frequency translation for the telecommunication applications that require a temperature range of -40°C to 85°C.

SCG2000i is well suited for use in line cards, service termination cards and similar functions to provide reliable reference, phase locked, synchronization and low phase gain for TDM, PDH, SONET and SDH network equipment. The SCG2000i provides a jitter filtered, wander following output signal synchronized to a superior Stratum or peer input reference signal.

Features

- **Industrial Temperature Range**
- **3.3V High Precision PLL**
- **Tri-State Capability**
- **Active Alarms**
- **Guaranteed Free Run (20ppm for 19.44MHz output and 30ppm for 125.0 MHz)**
- **1 Sec. Acquisition Time**

www.DataSheet4U.com

Bulletin	SG048
Page	1 of 16
Revision	P02
Date	28 Oct 02
Issued By	MBATTS

www.DataSheet4U.com

General Description

The SCG2000i provides high precision phase lock loop frequency translation for the telecommunication applications. The SCG2000i generates a CMOS output from an intrinsically low jitter, voltage controlled crystal oscillator. while providing a jitter attenuated, internal reference that is connected to a Reference Output pin.

SCG2000i is well suited for use in line cards, service termination cards and similar functions to provide reliable reference, phase locked, synchronization for TDM, PDH, SONET and SDH network equipment . The SCG2000i provides a low phase gain (<0.2dB), jitter filtered, wander following output signal synchronized to a superior Stratum or peer input reference signal.

The SCG2000i include the following features: Free Run, Tri-state and alarm outputs for Loss-of-Reference, (LOR), Loss-of-Lock, (LOL). During the LOR alarm, the SCG2000i will also enter a Free Run state which will guarantee a 20 ppm accurate output

with the 19.44 MHz model and 30 ppm accurate output with the 125.0 MHz model. Additionally the Free Run mode may be entered manually by asserting a high signal to the Free Run Enable pin. The outputs, except the oscillator output, may be put into the tri-state high impedance condition for external testing purposes by asserting a high signal to the Tri-State Enable pin.

The SCG2000i is 3.3 Volt components that typically draw less than 100 mA. All models have an acquisition time of approximately 1.0 second and can be used in applications that require temperature rating of -40° to 85° C. All models have a 33Ω resistor in series with the oscillator output. The SCG2000i maximum package dimensions are .78" x .83" x .35" on a six layer FR4 board with surface mount pins. Parts are assembled using high temperature solder to withstand surface mount reflow process.

Functional Block Diagram

Figure 1

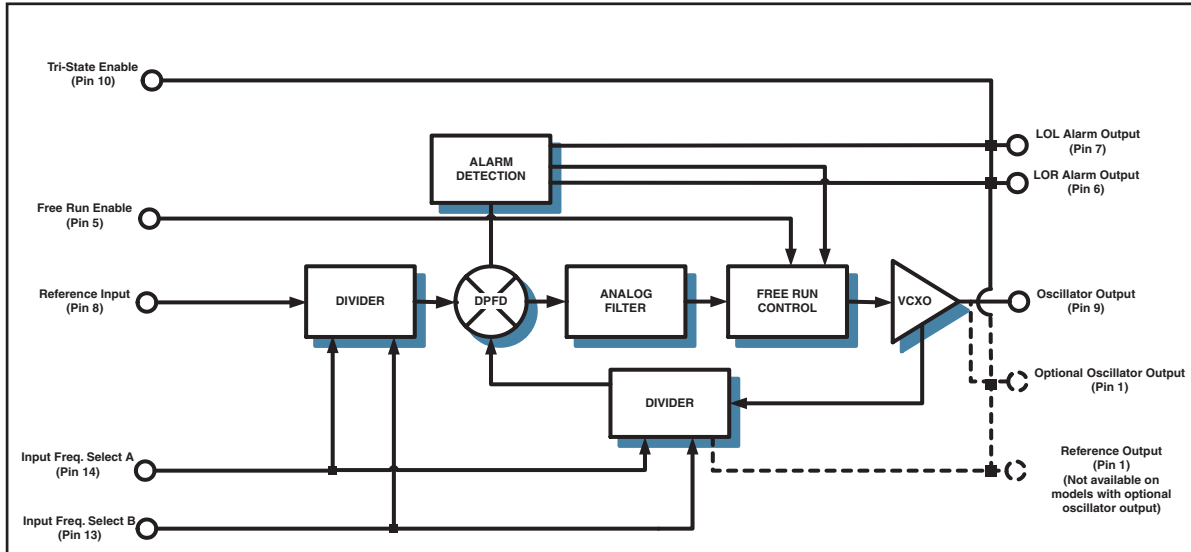

Model Comparison Table

Table 1

Model	Input Ref Freq	Max Duty Cycle	Reference Output (Pin #1)	Oscillator Output (Pin #9)	Notes
SCG2000	8-64 kHz	40/60	= Input Ref Freq.	1.544 MHz to 125.0 MHz	Basic Model
SCG2000i	8-16 kHz	45/55	= Input Ref Freq.	19.44 MHz, 125.0 MHz	Industrial Temp. Range
SCG2010	19.44 MHz	40/60	8 kHz	19.44 MHz	
SCG2020	19.44 MHz	40/60	19.44 MHz	77.76 MHz	
SCG2030	8-64 kHz	45/55	= Input Ref Freq.	1.544 MHz to 125.0 MHz	Tight Duty Cycle
SCG2050	8-64 kHz	40/60	19.44 MHz	77.76 MHz	
SCG2070	19.44 MHz	40/60	51.84 MHz, 77.76 MHz	51.84 MHz, 77.76 MHz	Ref Output = Osc Output

*Features which differentiate a model from the base model (SCG2000) are highlighted in boldface color and in the notes column.

Pin Description

Table 2

Pin #	Connection	Description
1	Reference Output	Output frequency is dependent on SCG model
2	TCK	JTAG pin that is used only by Connor-Winfield for programming. Do not connect
3	TMS	JTAG pin that is used only by Connor-Winfield for programming. Do not connect
4	Ground	Ground
5	Free Run Enable/TDI	Free Run enable pin. 1 = Free Run. Input is pulled to GND
6	Loss of Reference (LOR)	Alarm indicator. 1 = The reference has been lost.
7	Loss of Lock (LOL)	Alarm indicator. 1 = Phase lock has been lost
8	Reference Input	Input reference frequency
9	Oscillator Output	Output frequency is dependent on SCG model
10	Tri-State enable	Tri State control for all outputs except Oscillator Output. 1 = Hi-Z, 0 = normal. Input is pulled to GND.
11	Vcc	3.3V Supply Voltage.
12	TDO	JTAG pin that is used only by Connor-Winfield for programming. Do not connect
13	Input Freq. Select B	Control pin B used to select input frequency. Input is pulled to GND.
14	Input Freq. Select A	Control pin A used to select input frequency. Input is pulled to GND.

Typical Application

Figure 2

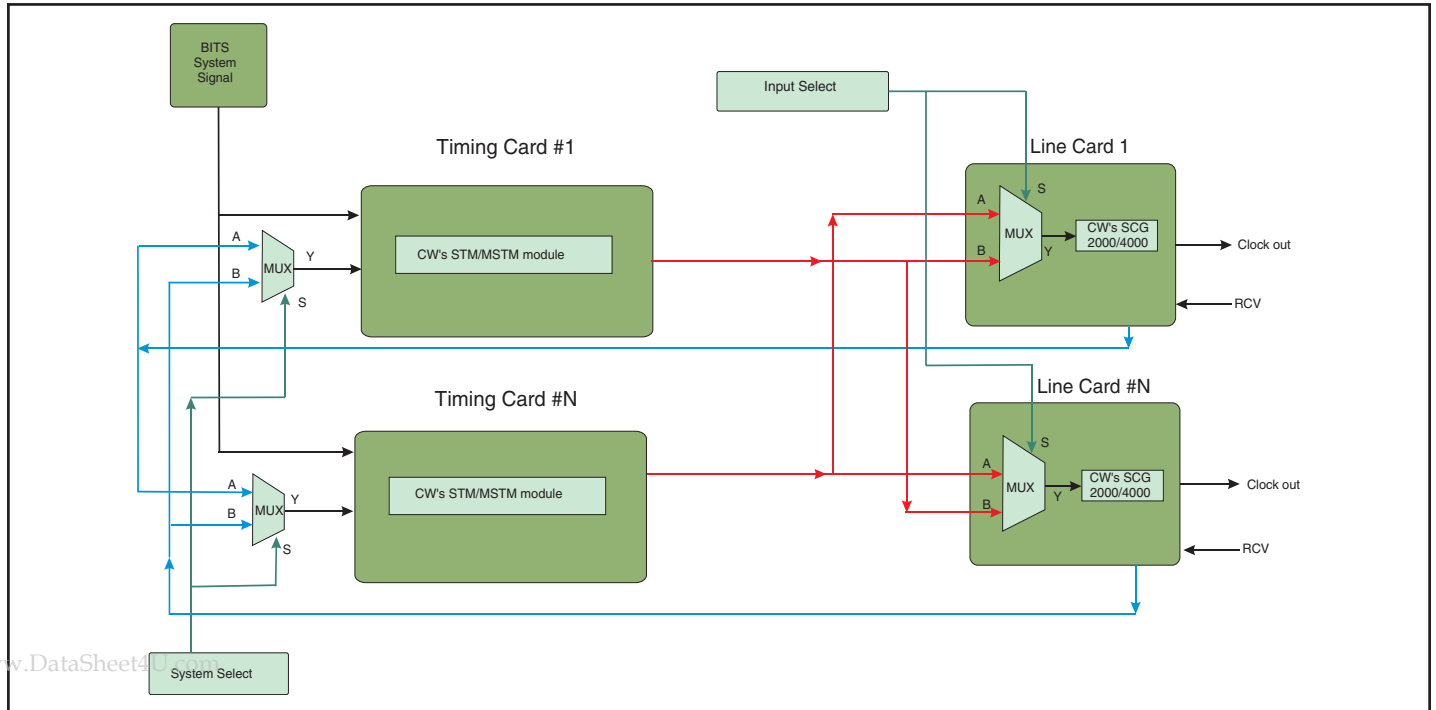

Absolute Maximum Rating

Table 3

Symbol	Parameter	Minimum	Nominal	Maximum	Units	Notes
V _{cc}	Power Supply Voltage	-0.5		4	Volts	
V _I	Input Voltage	-0.5		5.5	Volts	
T _s	Storage Temperature	-65		150	deg. C	

Specifications

Table 4

Parameter	Specifications	Notes
Voltage	3.3V ±5%	1.0
Current	100 mA Typical	
Temperature Range	-40° to 85°C	
Input Jitter Tolerance <i>(Input Jitter Frequencies ≥ 10 Hz)</i>	≥31.25us Typical	
Jitter Bandwidth	<15 Hz (8 Hz Typical)	
Acquisition Time	Approx 1.0 second	2.0
Capture/Pull-in Range	±32 ppm Minimum	
Output Duty Cycle	40/60 % Min/Max @ 50% Level	
Output Rise and Fall Time	3 ns @ 20% to 80% output level	
Output Load	30 pF	
Alarms	LOR, LOL Status on separate outputs	
Free Run Accuracy	±20 ppm (19.44 MHz output) ±30 ppm (125.0 MHz output)	
Package	Fr4 SM 0.78" x .83" x 0.35" (maximum)	
TDEV	60 ps Typical	
MTIE	750 ps Typical	
Reference Output/Oscillator Output Offset	≤ 8 ns	
Static Offset	± 26 ns Maximum	3.0
Dynamic Offset	± 28 ns Maximum	4.0

Input And Output Characteristics

Table 5

Symbol	Parameter	Minimum	Nominal	Maximum	Units	Notes
V _{IH}	High Level Input Voltage	2		5.5	V	
V _{IL}	Low Level Input Voltage	0		0.8	V	
T _{IO}	I/O to Output Valid			10	nS	
C _O	Output Capacitance			10	pF	
V _{HO}	High Level Output Voltage I _{oH} = -4mA	2.4				V _{cc} Min.
V _{IO}	Low Level Output Voltage I _{oL} = 8mA			0.4		V _{cc} Max.
T _{IR}	Input Reference Signal Pulse Width	30			nS	

NOTES: 1.0: Requires external regulation
 2.0: From a 20 ppm offset in reference frequency
 3.0: Offset between Reference Input and Reference Output @ room temp.
 4.0: Offset change between Reference Input and Reference Output over temperature range from room temperature



Output Jitter Specifications

Table 6

Frequency (MHz)	Jitter BW 10 Hz - 20 MHz		SONET Jitter BW 12 KHz - 20 MHz	
	pS (RMS)	m UI	pS (RMS)	m UI
19.44	10 Typ.	0.194 Typ.	1 Max., 0.5 Typ.	0.019 Max.
125.0	10 Typ.	1.250 Typ.	1 Max., 0.5 Typ.	0.125 Max.

Output Programming

Table 7

Tristate	Free Run	Output
0	0	Locked to reference selected (default)
1	X	Hi-Z Tristate condition
0	1	Free run

Alarm Status

Table 8

LOL Output	LOR Output	Alarm Output
0	0	No alarm
1	0	Loss-of-Lock
X	1	Loss-of-Reference

Maximum Package Dimensions

Figure 3

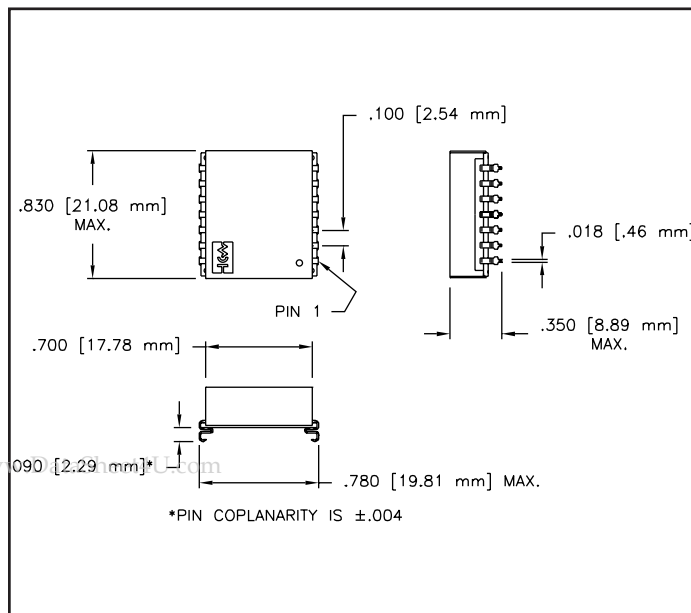

Recommended Footprint Dimensions

Figure 4

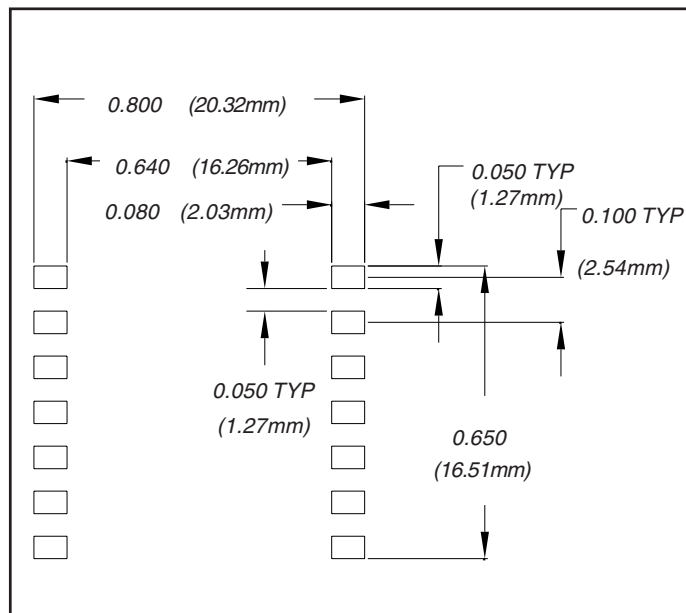

Input Reference Selection

Table 9

Input Sel A (Pin #14)	Input Sel B (Pin #13)	Reference Frequency (Pin #8)
0	0	8 kHz (default)
1	0	16 kHz (Not available w/ 125.0 MHz output)

Reference and Output Availability

Table 10

Input Reference (Pin #8)	Oscillator Output (Pin #9)	Reference Output (Pin #1)
8 kHz 16 kHz	19.44 MHz	8 kHz 16 kHz
8 kHz	125.0 MHz	8 kHz

Alarm Timing Diagram

Figure 5

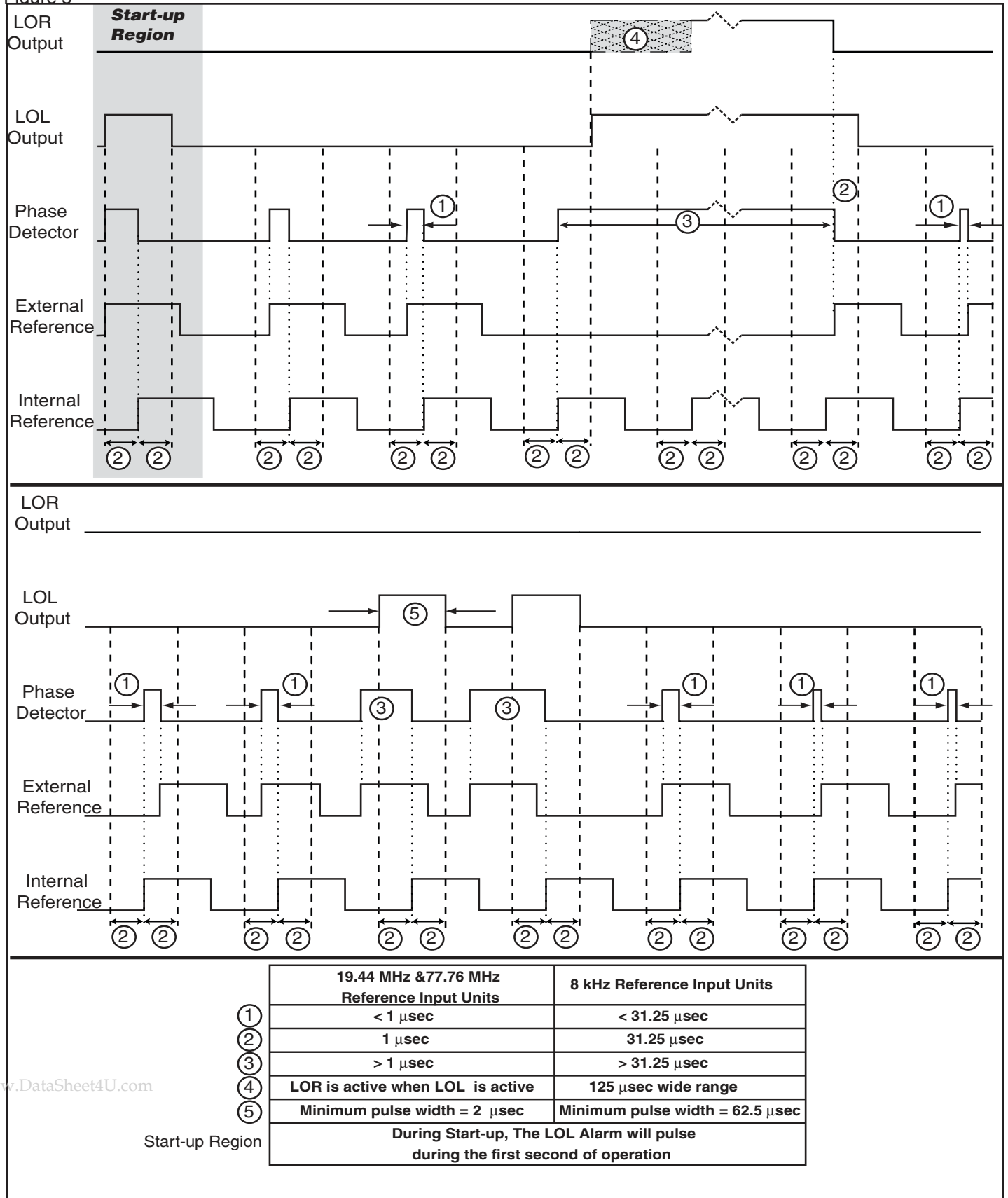

www.DataSheet4U.com

SCG2000 Jitter Attenuation

Figure 6

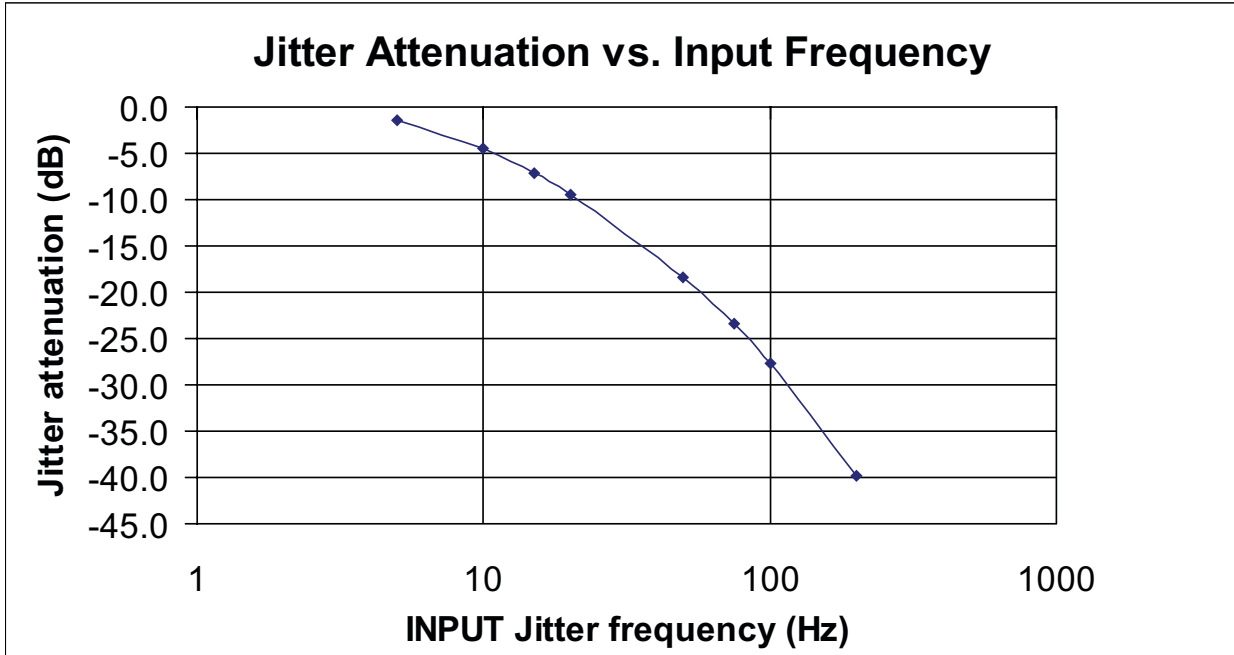

Typical System Test Setup

Figure 7

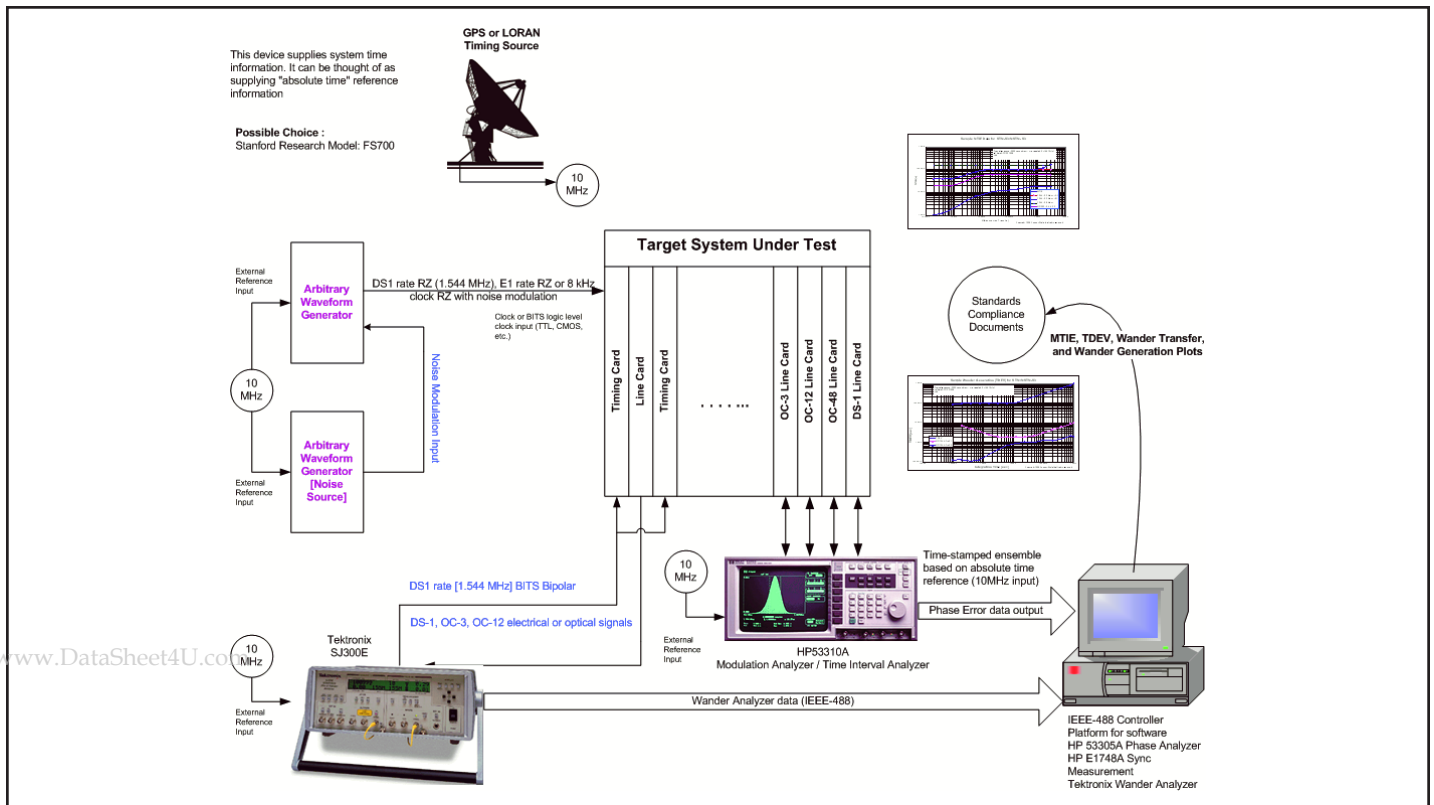

SCG2000i Typical TDEV

Figure 8

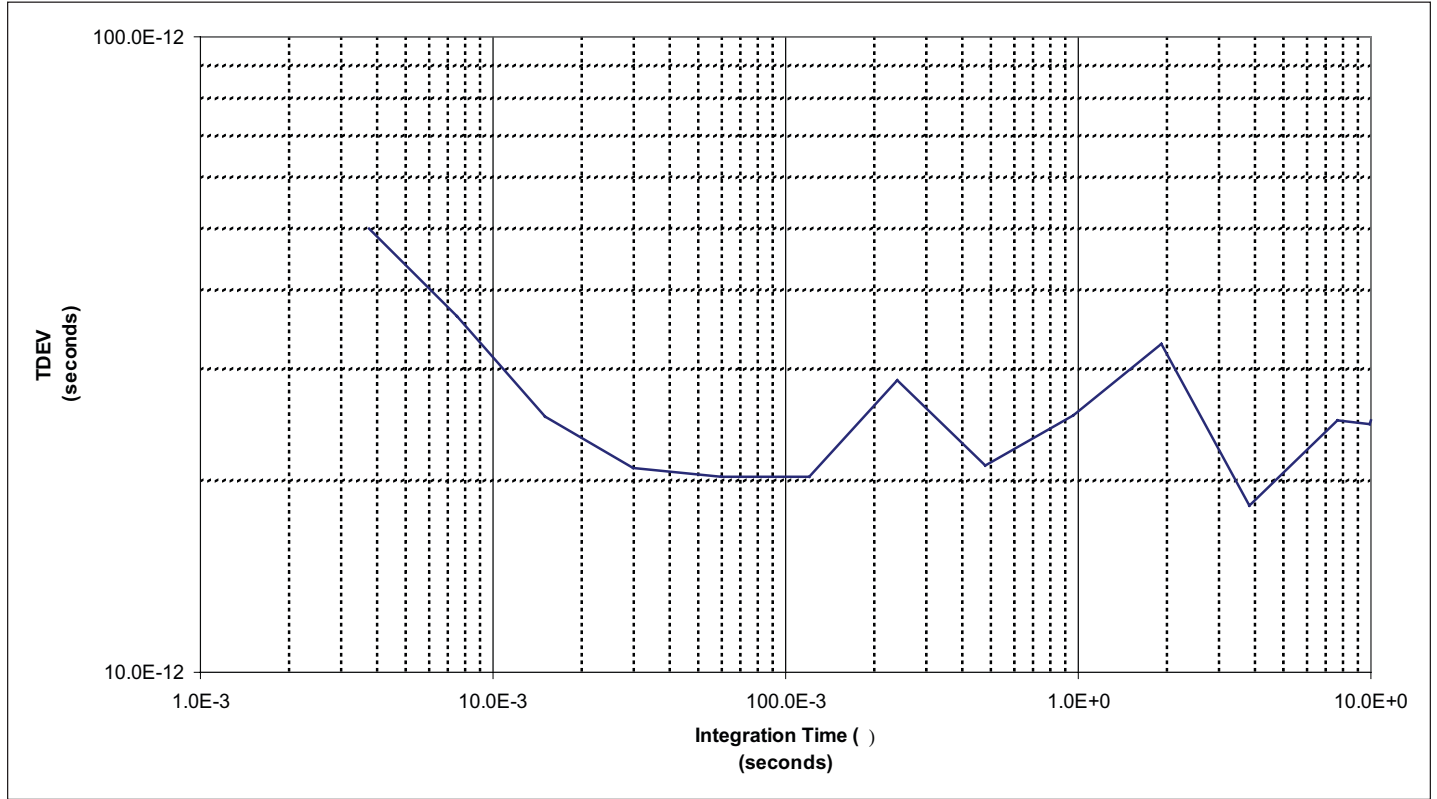

SCG2000i Typical MTIE

Figure 9

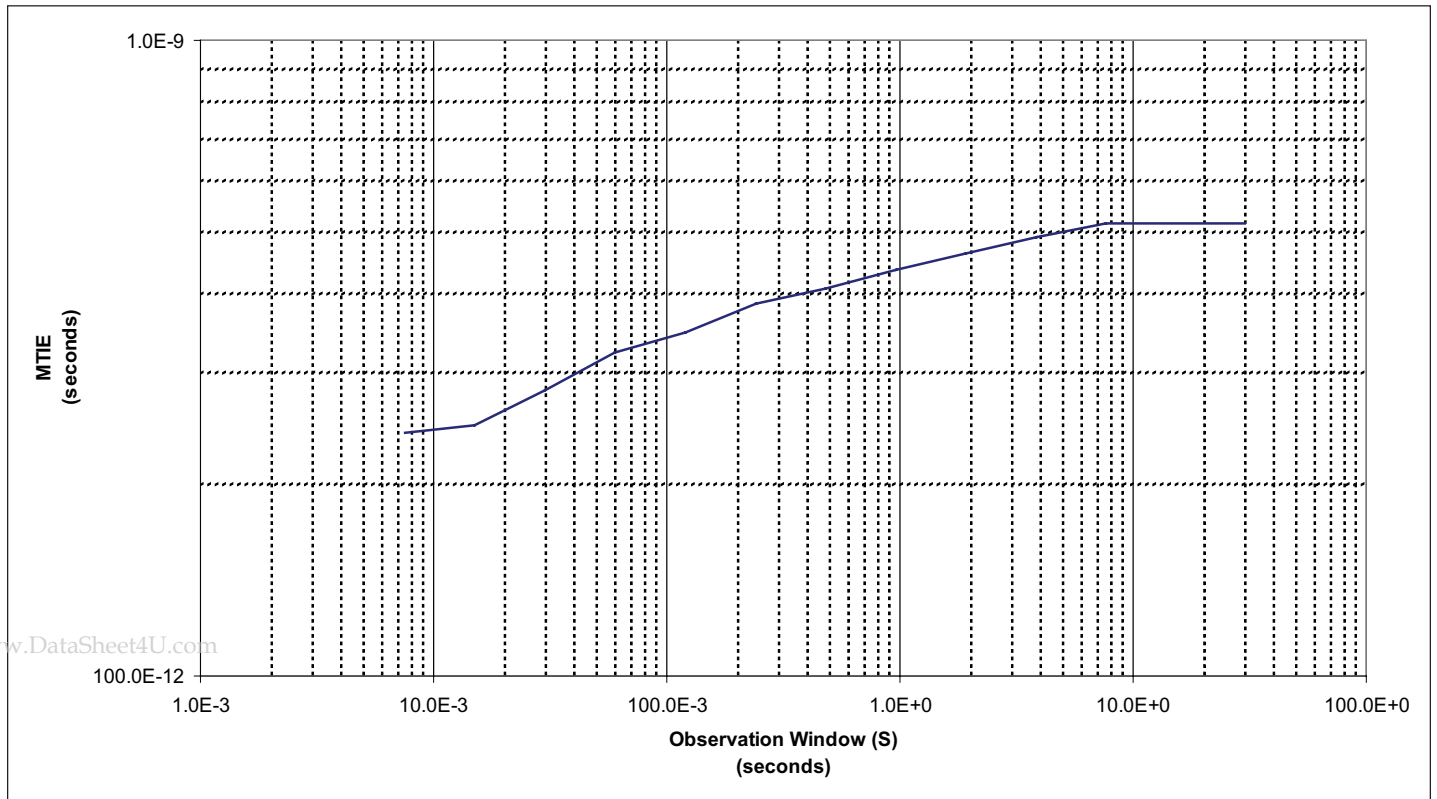

SCG2000i Switch from Free Run to a new Reference

Figure 10

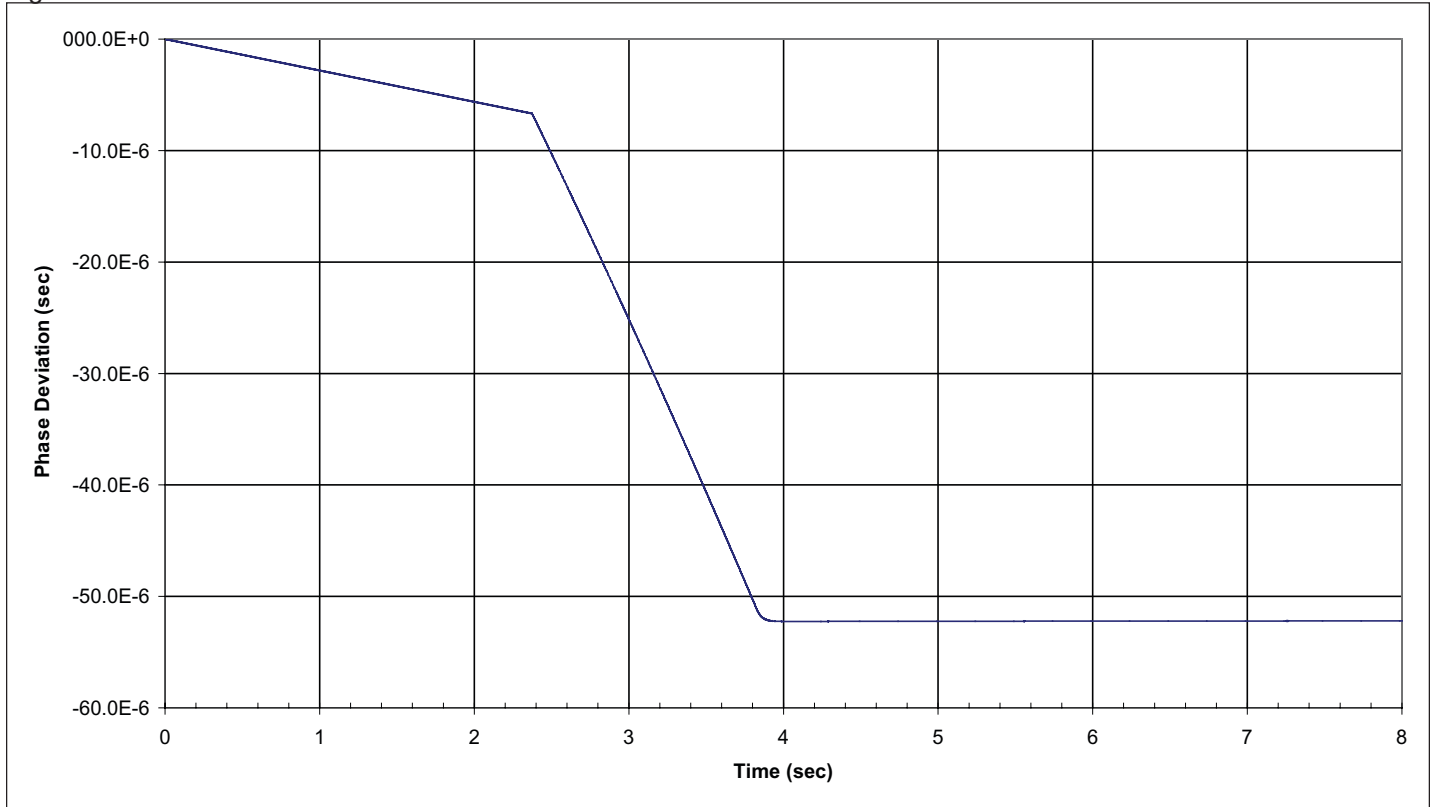

SCG2000i Switch from a Reference to Free Run

Figure 11

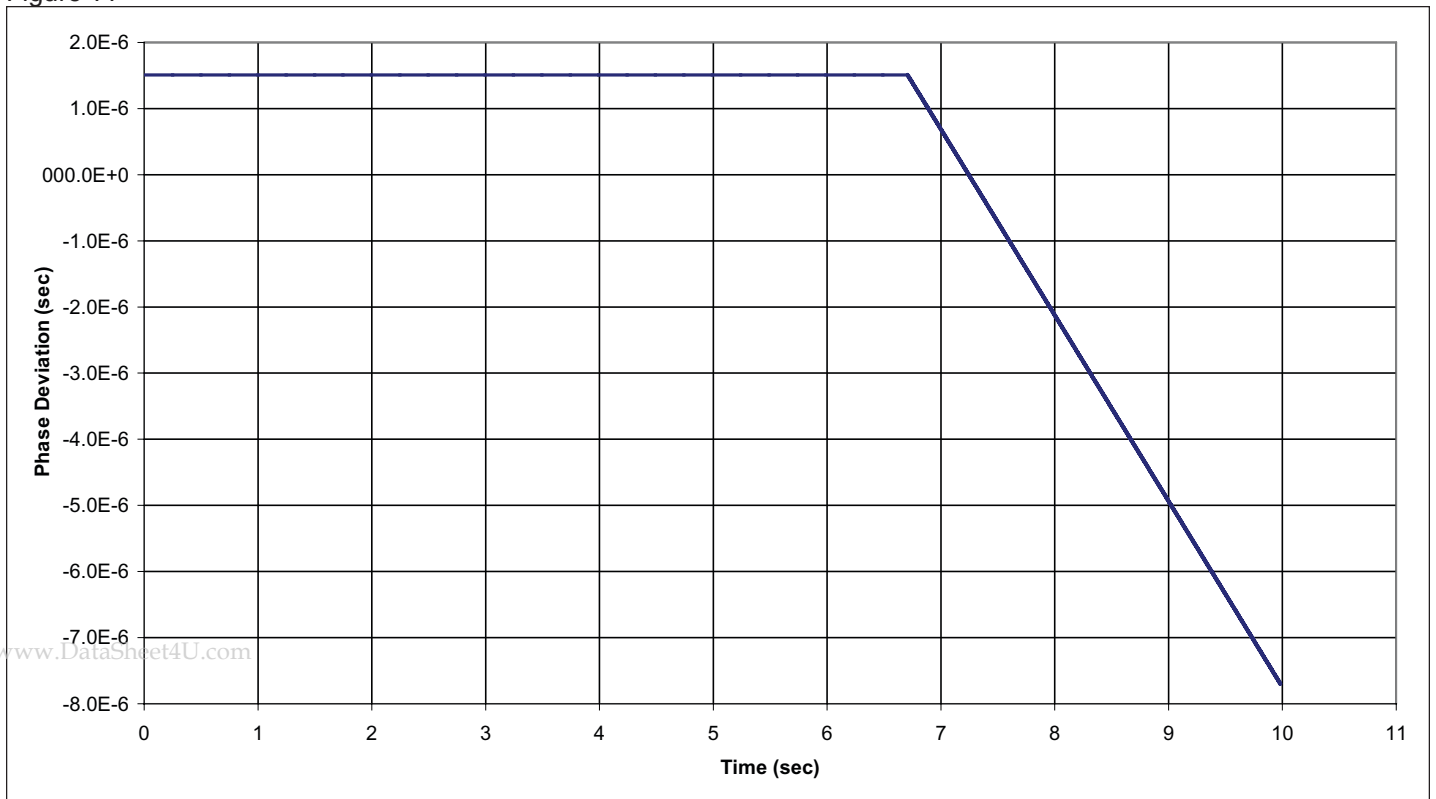

SCG2000i Step Response due to a -20ppm Freq. Step

Figure 12

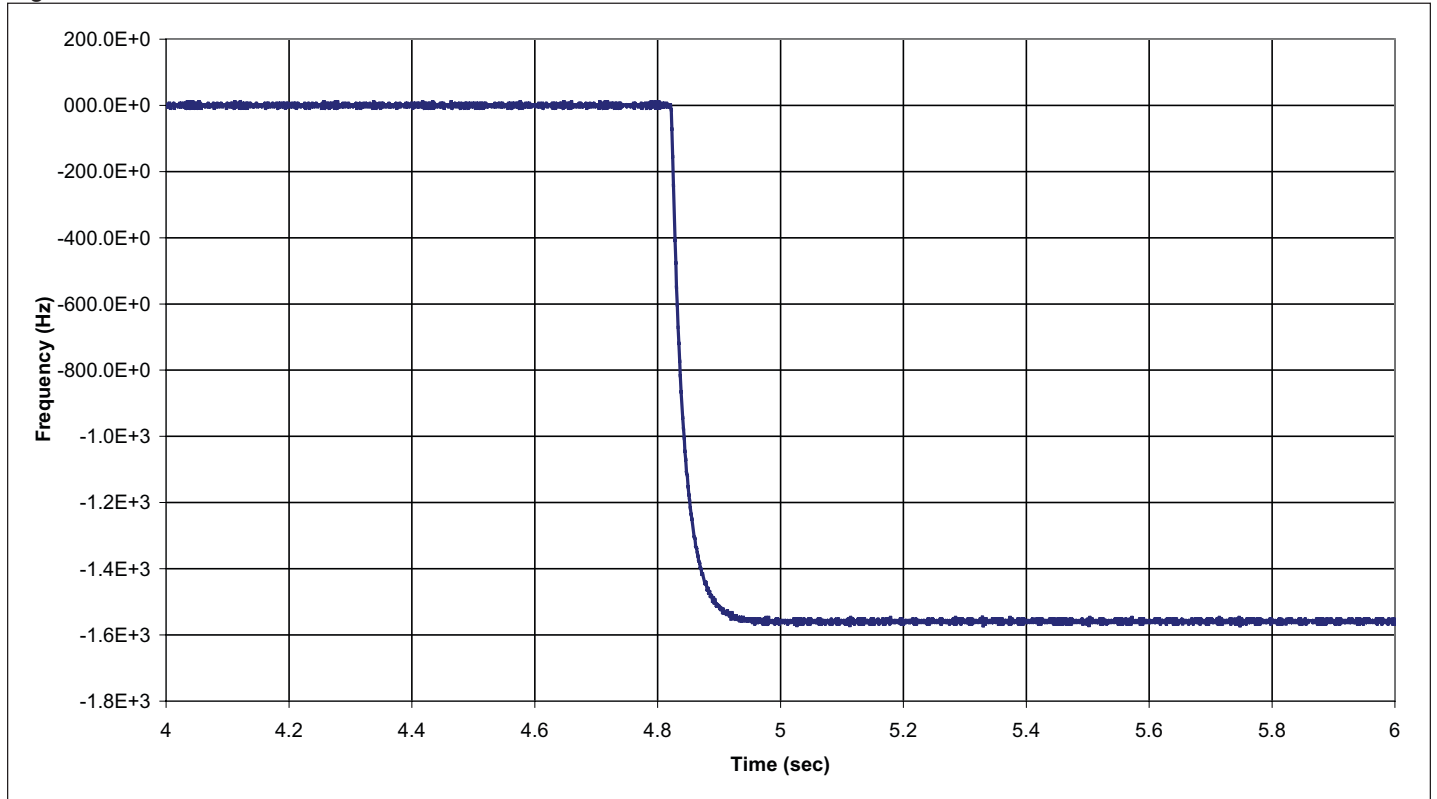

SCG2000i 1μs Phase Transient Response

Figure 13

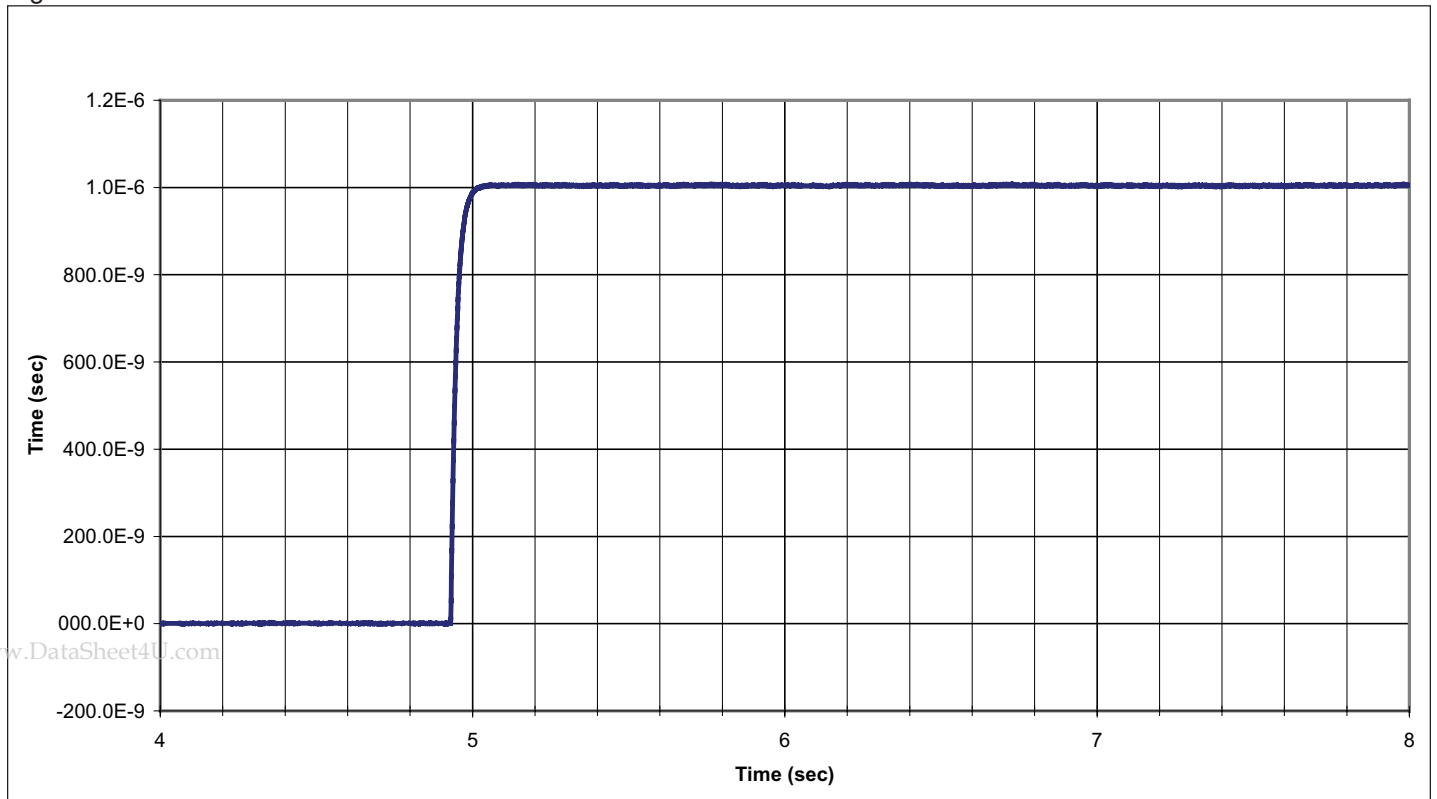

Tape and Reel Dimensions

Figure 14

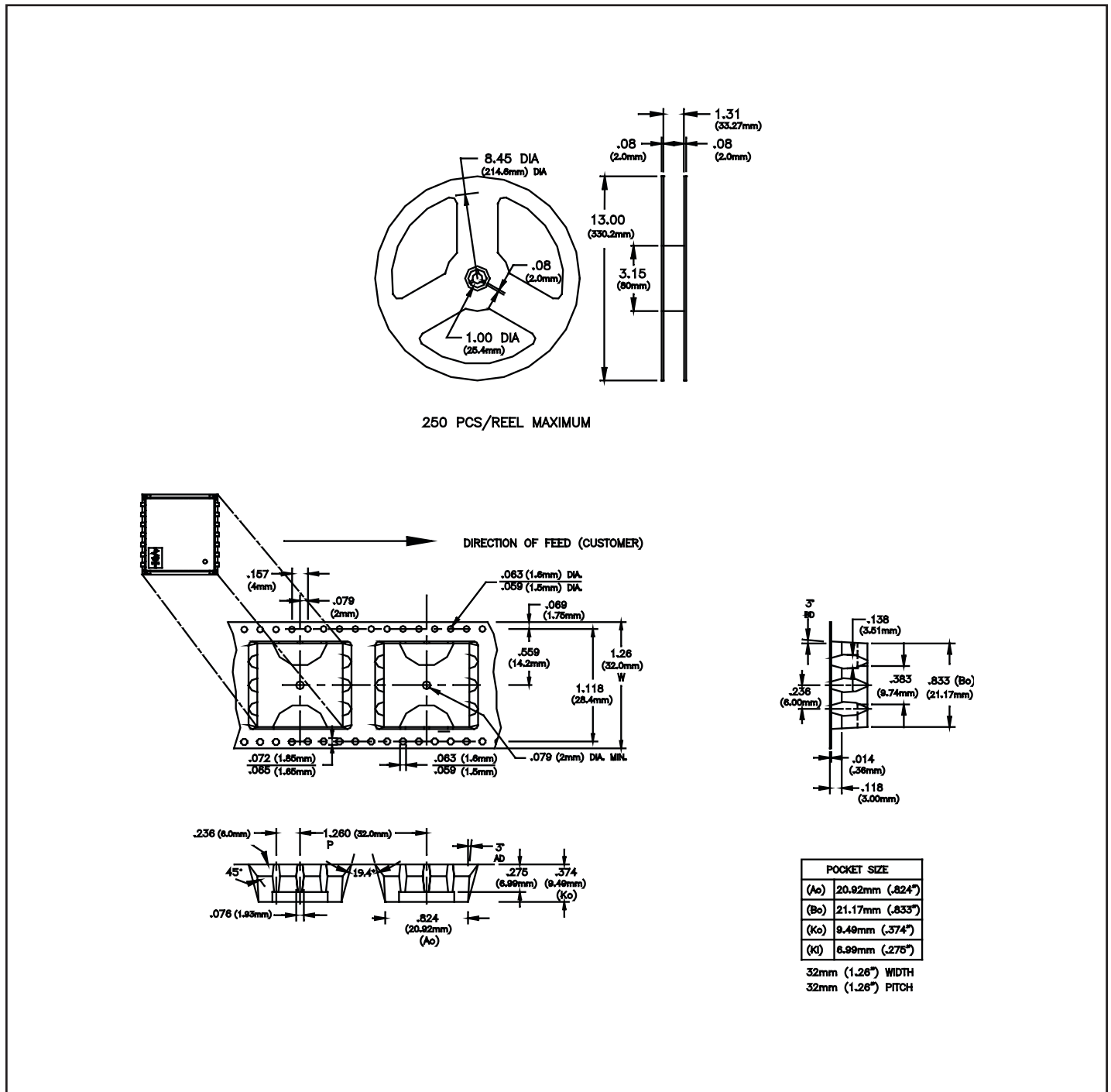

www.DataSheet4U.com



Solder Profile

Figure 15

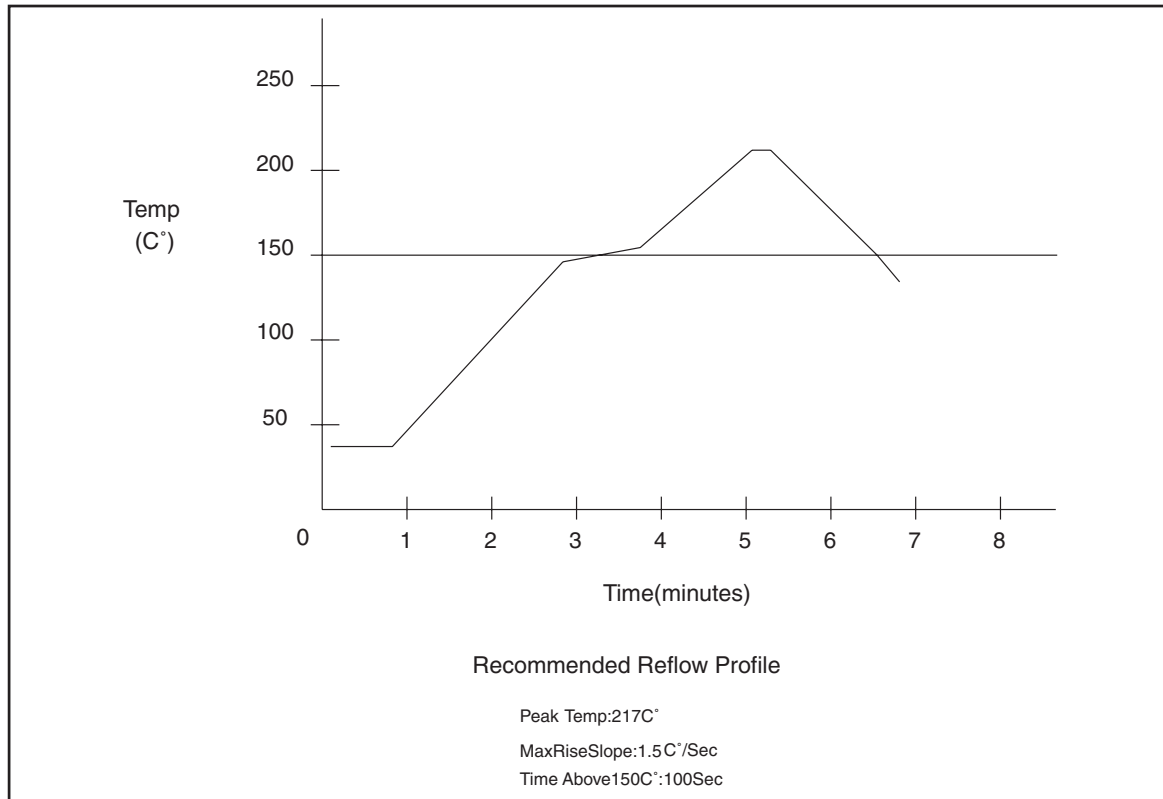

Ordering Information

SCG{XXXX}-{FFF.FFF}{M}

XXXX equals a specific model (2000i)

FFF.FFF equals the Oscillator Output frequency (001.544, 002.048, 016.384, 019.44, 020.48, 037.056, 044.736, 049.152, 051.84, 077.76, 125.00)

M equals MHZ and is added to all part numbers

Example: To order an SCG2000i with an Oscillator Output of 19.44 MHz,
Order part number SCG2000i-019.44M

Please contact Connor-Winfield for other frequencies that may be available.

www.DataSheet4U.com

www.DataSheet4U.com



Revision	Revision Date	Note
P00	5/14/02	Preliminary Informational Release
P01	5/28/02	Corrected Temp Range in General Description
P02	10/28/02	Added 125.0 MHz model

www.DataSheet4U.com





2111 Comprehensive Drive
Aurora, Illinois 60505
Phone: 630-851-4722
Fax: 630-851-5040
www.conwin.com