

CERAMIC SMD TYPE

SCO-10

- External Dimensions : 7.0 × 5.0 mm
- 1.8 V to 5.0 V Operating Supply Voltage Range
- Low Power Consumption
- CMOS Output
- Tri-state Function Available
- Pb-free and RoHS Compliance

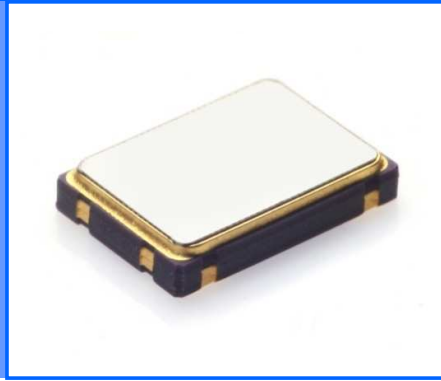

■ ELECTRICAL SPECIFICATIONS

ITEM	Value	Remarks
Output Logic Type	CMOS	CMOS XO
Frequency Range	1.000 MHz to 200.000 MHz	
Supply Voltage(V _{DD})	1.8 V _{DC} ±5 %, 2.5 V _{DC} ±5 %, 3.3 V _{DC} ±5 %, 5.0 V _{DC} ±10 %	
Operating Temperature Range	0 to +70 °C, -20 to +70 °C, -40 to +85 °C	
Storage Temperature Range	-55 to +125 °C	
Frequency Stability	±20 ppm, ±25 ppm, ±50 ppm, ±100 ppm Max.	Over operating temperature range
Input Current	3mA(1.8V), 4mA(2.5V), 5mA(3.3V), 7mA(5V) Max. 4mA(1.8V), 5mA(2.5V), 7mA(3.3V), 10mA(5V) Max. 10mA(1.8V), 15mA(2.5V), 20mA(3.3V), 25mA(5V) Max. 13mA(1.8V), 17mA(2.5V), 25mA(3.3V) Max. 20mA(1.8V), 30mA(2.5V), 40mA(3.3V) Max. 37mA(1.8V), 50mA(2.5V), 70mA(3.3V) Max. 58mA(2.5V), 75mA(3.3V) Max.	1.000 MHz to 25.000 MHz 25.001 MHz to 40.000 MHz 40.001 MHz to 80.000 MHz 80.001 MHz to 100.000 MHz 100.001 MHz to 125.000 MHz 125.001 MHz to 160.000 MHz 160.001 MHz to 200.000 MHz
Output Voltage Logic High(V _{OH})	90 % of V _{DD} Min.	
Output Voltage Logic Low(V _{OL})	10 % of V _{DD} Max.	
Rise / Fall Time	7 ns Max.(1.000 MHz to 39.999 MHz) 4 ns Max.(40.000 MHz to 59.999 MHz) 3 ns Max.(60.000 MHz to 99.999 MHz) 2 ns Max.(100.000 MHz to 200.000 MHz)	Measured over 10 % to 90 % of waveform
Duty Cycle	45 to 55 %, 40 to 60 %	Measured at 50 % of waveform
Start-up Time	10 ms Max.	
Output Load Condition(CMOS)	15 pF Max.	
Output Enable Function (V _{IH} and V _{IL})	70 % of V _{DD} min. to Enable Output 30 % of V _{DD} max. to Disable Output	High Impedance
RMS Phase Jitter	1 ps Max.	BW : 12 kHz to 20 MHz
Frequency Aging	±3 ppm Max.	25°C, First year

■ MECHANICAL DIMENSIONS (mm)

■ LAND PATTERN (mm)

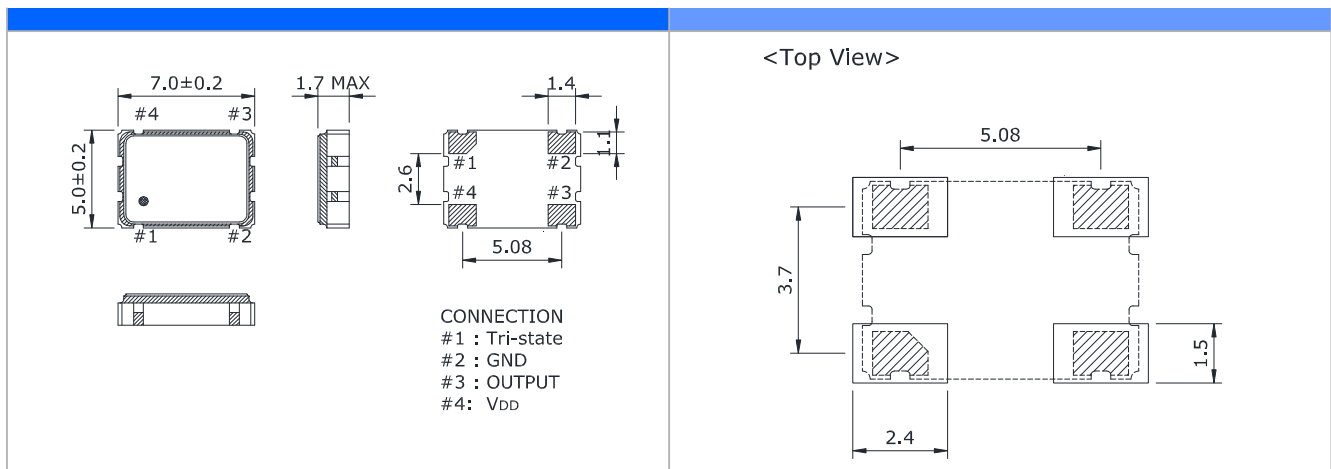

■ PART NUMBERING GUIDE

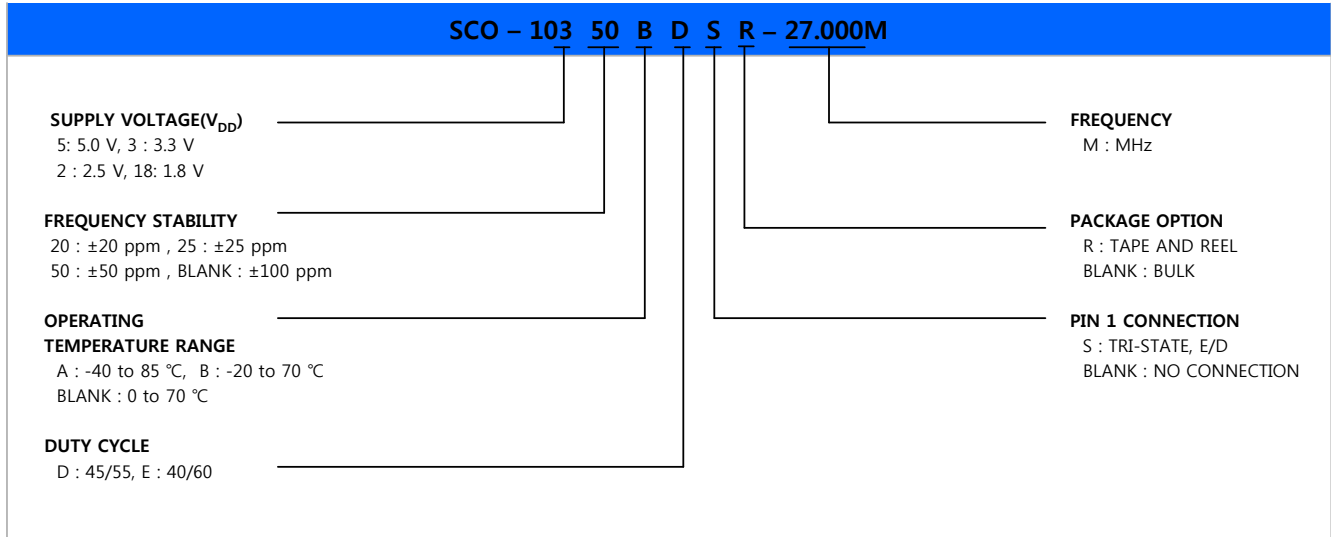

■ TEST CIRCUIT (CMOS)

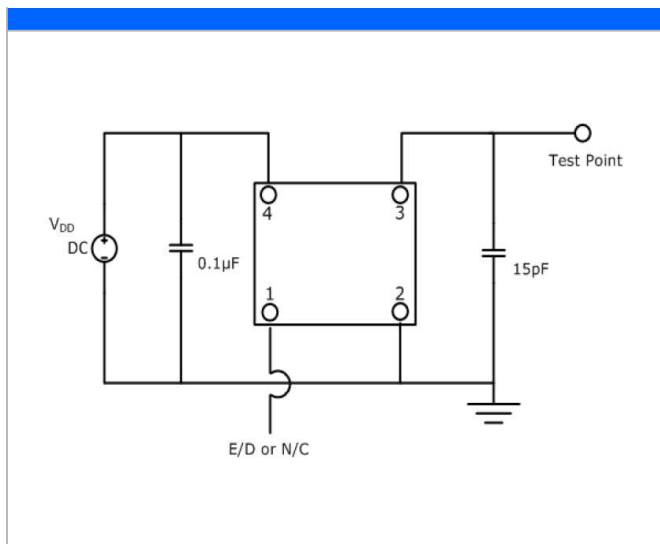

■ WAVEFORM (CMOS)

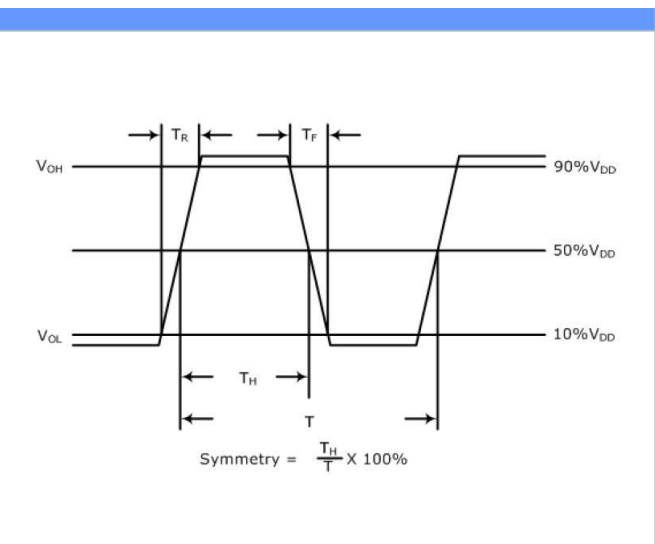

■ ENVIRONMENTAL & MECHANICAL SPECIFICATIONS

Temperature Cycling	MIL-STD-883, Method 1010, Condition B
Fine Leak Test	MIL-STD-883, Method 1014, Condition A
Gross Leak Test	MIL-STD-883, Method 1014, Condition C
Mechanical Shock	MIL-STD-883, Method 2002, Condition B
Vibration	MIL-STD-883, Method 2007, Condition A
Moisture Resistance	MIL-STD-883, Method 1004
Moisture Sensitivity	J-STD-020, MSL 1
Resistance to Soldering Heat	MIL-STD-202, Method 210, Condition K
Solderability	MIL-STD-883, Method 2003

REFLOW PROFILE

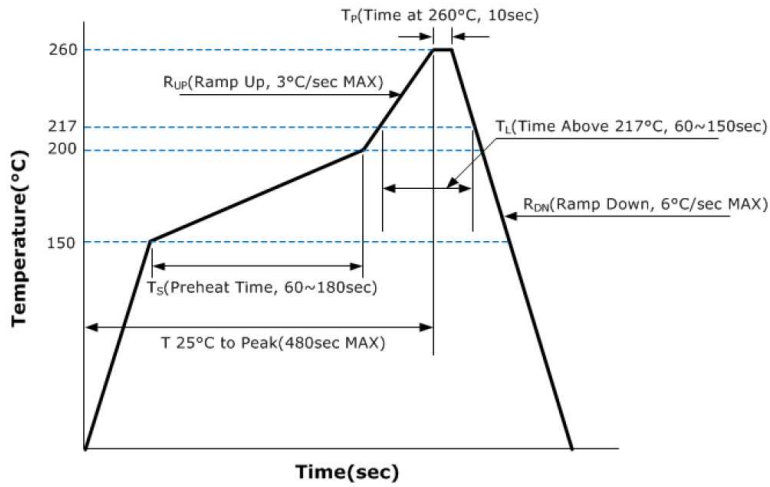

MARKING GUIDE

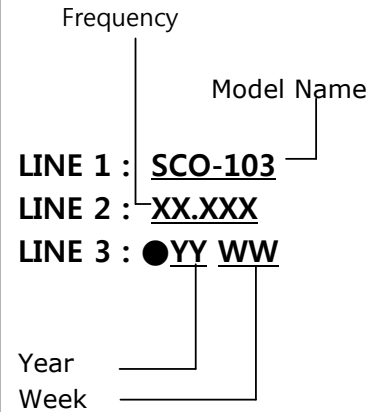

TAPE AND REEL DIMENSIONS

MAT'L : P.S
 COLOR : WHITE&BLACK
 REFERANCE R=0.2

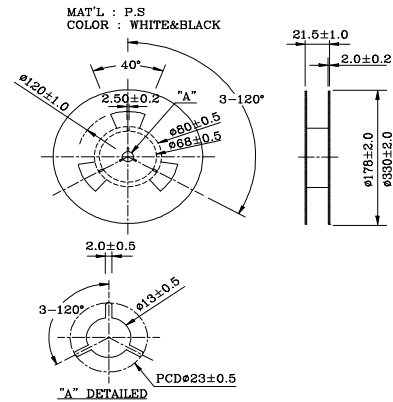
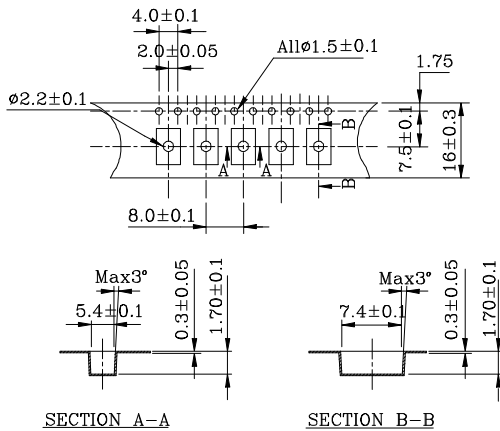

NOTE
 1. COVER TAPE : 13~14mm(WIDTH)X0.06mm(t) MAT'L : PET
 2. COLOR : NONTRANSPARENT