



## Up to 24V Supply, 4-A Single Channel High Speed Low Side Driver

### FEATURES

- Wide Supply Voltage Range: 4.5V - 24V
- 4A Peak Source Current and 4A Peak Sink Current
- Dual Input Configuration: Non-Inverting (IN+) or Inverting (IN-) Input
- Negative Input Voltage Capability: Down to -5V
- TTL Input-Logic Threshold
- Propagation Delay: 12ns
- Fast Rising and Falling Times: 8ns and 6ns
- Low Quiescent Current: 23uA
- Under Voltage Lock Out Protection of Supply Voltage
- Output Low When Input Floating
- Thermal Shutdown Protection: 170°C
- Available in TSOT23-5L Package

### APPLICATIONS

- MOSFET Driver
- IGBT Gate Driver
- Gate Driver for GaN Device
- Switching Power Supply
- Motor Control, Solar Power

### DESCRIPTION

The SCT51240 is a wide supply, single channel, high speed, low side gate driver for power MOSFET, IGBT, and wide band-gap device such as GaN. The 24V power supply rail enhances the driver output ringing endurance during the power device transition. The capability to switching below 5V power supply makes the SCT51240 work well for the low voltage threshold Power device.

The SCT51240 can source and sink 4A peak current along with rail-to-rail output driving capability. The minimum 12ns input to output propagation delay enables it suitable for high frequency power converter application. The SCT51240 features wide input hysteresis that is compatible for TTL low voltage logic. The SCT51240 has the capability to handle negative input down to -5V, which increases the input noise immunity. The IN+ and IN- input provides the flexibility to configure the SCT51240 either as non-inverting or inverting driver.

The SCT51240 has very low quiescent current that reduces the stand by loss in the power converter. The SCT51240 driver adopts non-overlap driver design to avoid the shoot-through of output stage.

The SCT51240 features 170°C thermal shut down protection and operates over a wide temperature range -40°C to 150°C. The SCT51240 is available in TSOT23-5L package.

### TYPICAL APPLICATION

SCT51240 Typical Application

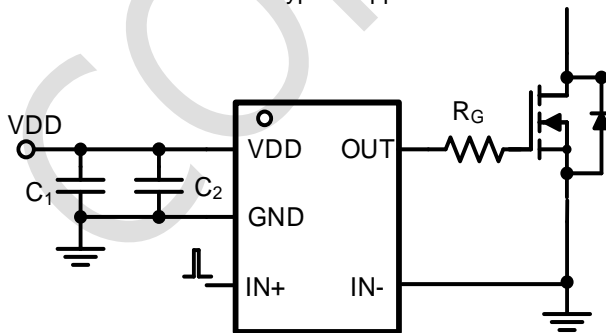

Application Waveform

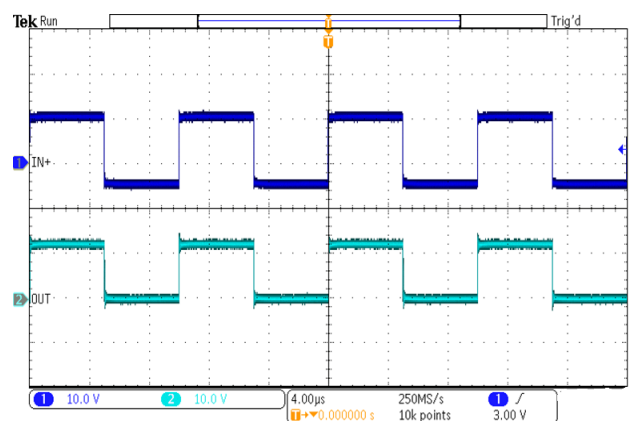

# SCT51240

## REVISION HISTORY

NOTE: Page numbers for previous revisions may differ from page numbers in the current version.

Revision 0.9 Preliminary datasheet.

## DEVICE ORDER INFORMATION

PART NUMBER	PACKAGE MARKING	PACKAGE DISCRIPTION
SCT51240TWB	1240	TSOT23-5

1) For Tape & Reel, Add Suffix R (e.g. SCT51240TWBR).

## ABSOLUTE MAXIMUM RATINGS

Over operating free-air temperature unless otherwise noted<sup>(1)</sup>

DESCRIPTION	MIN	MAX	UNIT
IN+, IN-	-5	26	V
OUT	-0.3	26	V
VDD	-0.3	26	V
Operating junction temperature $T_J$ <sup>(2)</sup>	-40	150	°C
Storage temperature $T_{STG}$	-65	150	°C

## PIN CONFIGURATION

Top View: TSOT23-5pin  
Plastic

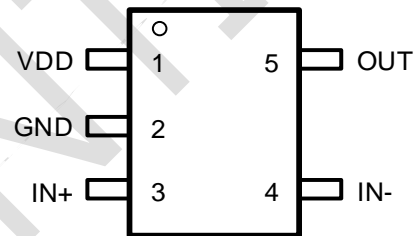

(1) Stresses beyond those listed under Absolut Maximum Rating may cause device permanent damage. The device is not guaranteed to function outside of its Recommended Operation Conditions.

(2) The IC includes over temperature protection to protect the device during overload conditions. Junction temperature will exceed 150°C when over temperature protection is active. Continuous operation above the specified maximum operating junction temperature will reduce lifetime

## PIN FUNCTIONS

NAME	NO.	PIN FUNCTION
VDD	1	Power supply of driver, must be decoupled by ceramic cap. A 0.1uF, and 1uF or 10uF are recommended.
GND	2	Power ground. Must be soldered directly to ground planes for improved thermal performance and electrical contact.
IN+	3	Non-inverting logic input, TTL compatible. Floating logic low. In Non-Inverting configuration, apply PWM signal on IN+. In inverting configuration, connect IN+ to VDD and IN- to GND.
IN-	4	Inverting logic input, TTL compatible. Floating logic low. In Non-Inverting configuration, connect IN- to GND. In inverting configuration, apply PWM signal on IN- and IN+ to VDD.
OUT	5	Gate driver output.

**RECOMMENDED OPERATING CONDITIONS**

Over operating free-air temperature range unless otherwise noted

PARAMETER	DEFINITION	MIN	MAX	UNIT
V <sub>DD</sub>	Supply voltage range	4.5	24	V
V <sub>OUT</sub>	Output voltage range	4.5	24	V
V <sub>IN+,IN-</sub>	Input voltage range	-5	24	V
T <sub>J</sub>	Operating junction temperature	-40	150	°C

**ESD RATINGS**

PARAMETER	DEFINITION	MIN	MAX	UNIT
V <sub>ESD</sub>	Human Body Model (HBM), per ANSI-JEDEC-JS-001-2014 specification, all pins <sup>(1)</sup>	-2	+2	kV
	Charged Device Model (CDM), per ANSI-JEDEC-JS-002-2014 specification, all pins <sup>(1)</sup>	-1	+1	kV

(1) HBM and CDM stressing are done in accordance with the ANSI/ESDA/JEDEC JS-001-2014 specification

**THERMAL INFORMATION**

PARAMETER	THERMAL METRIC	TSOT23-5	UNIT
R <sub>θJA</sub>	Junction to ambient thermal resistance <sup>(1)</sup>	89	°C/W
R <sub>θJC</sub>	Junction to case thermal resistance <sup>(1)</sup>	39	

(1) SCT provides R<sub>θJA</sub> and R<sub>θJC</sub> numbers only as reference to estimate junction temperatures of the devices. R<sub>θJA</sub> and R<sub>θJC</sub> are not a characteristic of package itself, but of many other system level characteristics such as the design and layout of the printed circuit board (PCB) on which the SCT51240 is mounted, and external environmental factors. The PCB board is a heat sink that is soldered to the leads and thermal pad of the SCT51240. Changing the design or configuration of the PCB board changes the efficiency of the heat sink and therefore the actual R<sub>θJA</sub> and R<sub>θJC</sub>.

# SCT51240

## ELECTRICAL CHARACTERISTICS

V<sub>DD</sub>=12V, T<sub>J</sub>=-40°C~125°C, typical values are tested under 25°C.

SYMBOL	PARAMETER	TEST CONDITION	MIN	TYP	MAX	UNIT
<b>Power Supply and Output</b>						
V <sub>DD</sub>	Operating supply voltage		4.5		24	V
V <sub>DD_UVLO</sub>	Input UVLO Hysteresis	V <sub>DD</sub> rising		4.2 300	4.5	V mV
I <sub>Q</sub>	Quiescent current	IN+=IN-=GND, VDD=3.5V		38		uA
		IN+=IN-=GND, VDD=12V		120		uA
<b>INPUTS</b>						
V <sub>IN+</sub>	Input+ logic high threshold			2.1	2.4	V
V <sub>IN+</sub>	Input+ logic low threshold		0.8	1.0		V
V <sub>IN+_Hys</sub>	Hysteresis			1.1		V
V <sub>IN-_H</sub>	Input- logic high threshold			2.1	2.4	V
V <sub>IN-_L</sub>	Input- logic low threshold		0.8	1.0		V
V <sub>IN-_Hys</sub>	Hysteresis			1.1		V
<b>OUTPUTS</b>						
V <sub>DD_VO</sub>	Output High Voltage (only PMOS ON)	I <sub>O</sub> UT=10mA			150	mV
V <sub>OL</sub>	Output Low Voltage	I <sub>O</sub> UT=10mA			10	mV
I <sub>SINK/SRC</sub>	Output Sink/Source peak current	C <sub>Load</sub> =10nF, F <sub>sw</sub> =1kHz		4		A
ROH	Output pull high resistance (only PMOS ON)	I <sub>O</sub> UT= - 10mA		8.5		Ω
ROL	Output pull low resistance	I <sub>O</sub> UT= 10mA		0.6		Ω
<b>Timing</b>						
T <sub>R</sub>	Output rising time	C <sub>Load</sub> =1nF		9	20	ns
T <sub>F</sub>	Output falling time	C <sub>Load</sub> =1nF		6	20	ns
T <sub>D_IN+</sub>	Input to output propagation delay, Rising edge			12	25	ns
	IN+ to output propagation delay, Falling edge			12	25	ns
T <sub>D_IN-</sub>	IN- to output propagation delay, Rising			12	25	ns
	Enable to output propagation delay, Falling			12	25	ns
T <sub>MIN_ON</sub>	Minimum input pulse width	C <sub>Load</sub> =1nF		20	30	ns
<b>Protection</b>						
T <sub>SD</sub>	Thermal shutdown threshold	T <sub>J</sub> rising		170		°C
	Hysteresis			25		°C

**TYPICAL CHARACTERISTICS**

V<sub>DD</sub>=12V, T<sub>A</sub>= 25°C.

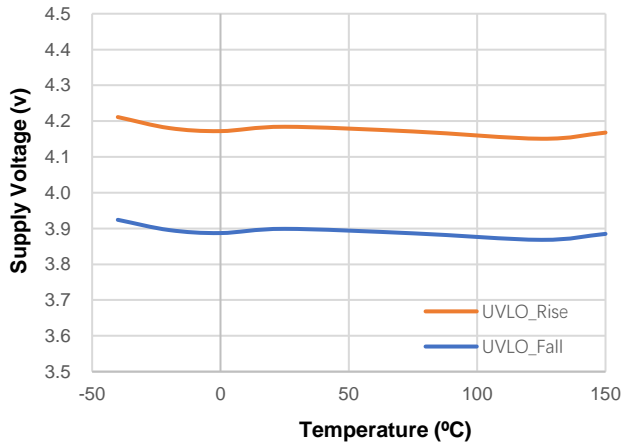

Figure 1. UVLO Vs Temperature

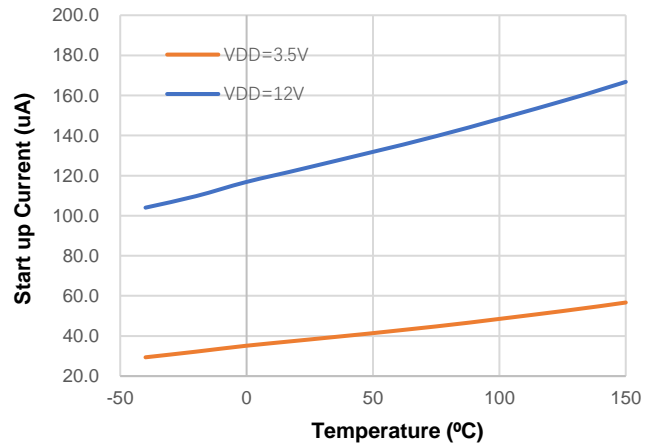

Figure 2. Start-up current Vs Temperature

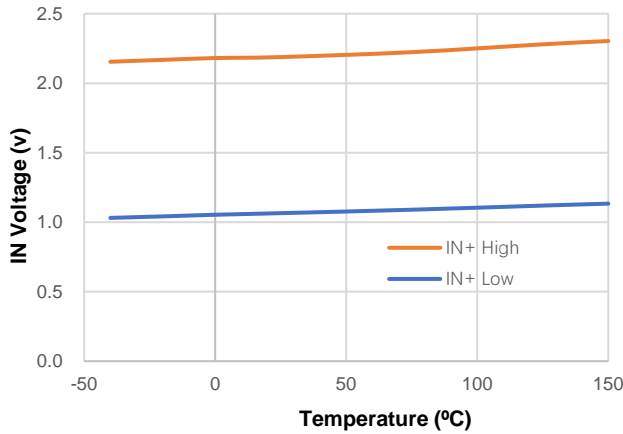

Figure 3. IN Threshold Vs Temperature

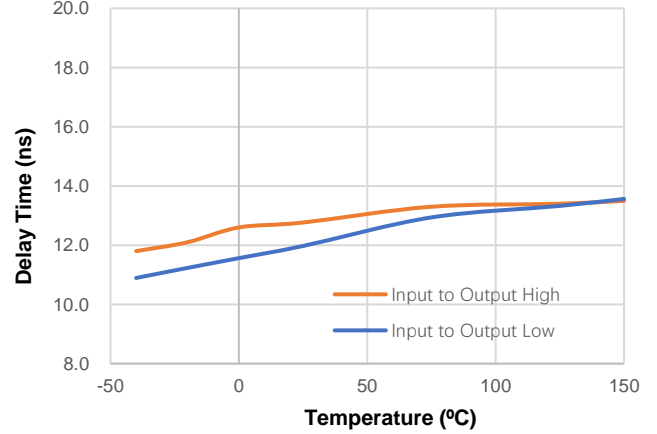

Figure 4. Input to Output Propagation Delay vs Temperature

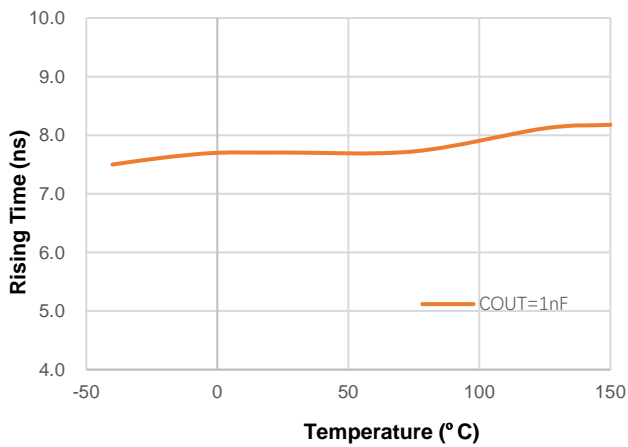

Figure 5. Output Rising Time Vs Temperature

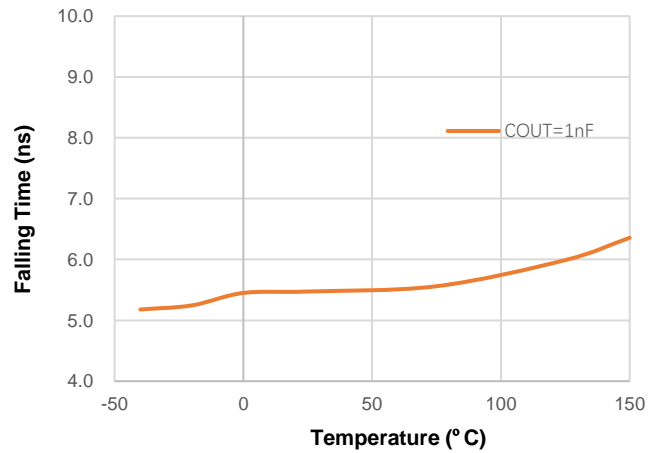

Figure 6. Output Falling Time Vs Temperature

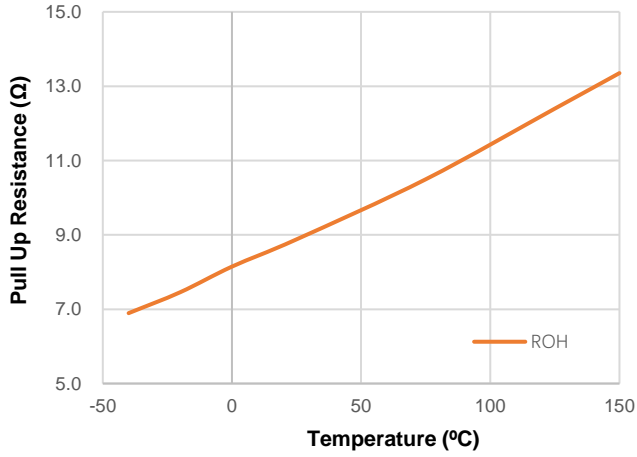

Figure 7. ROH vs Temperature

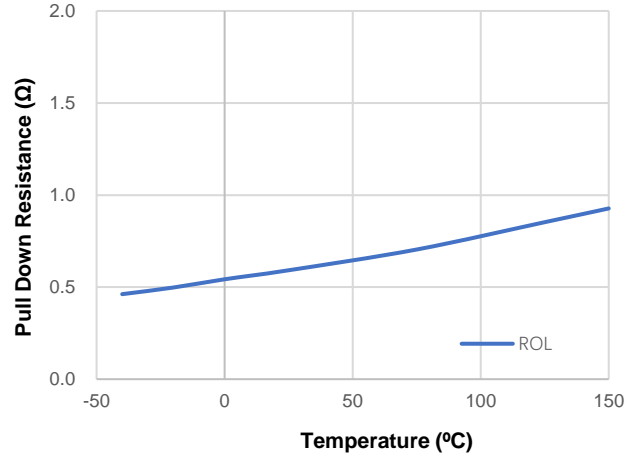
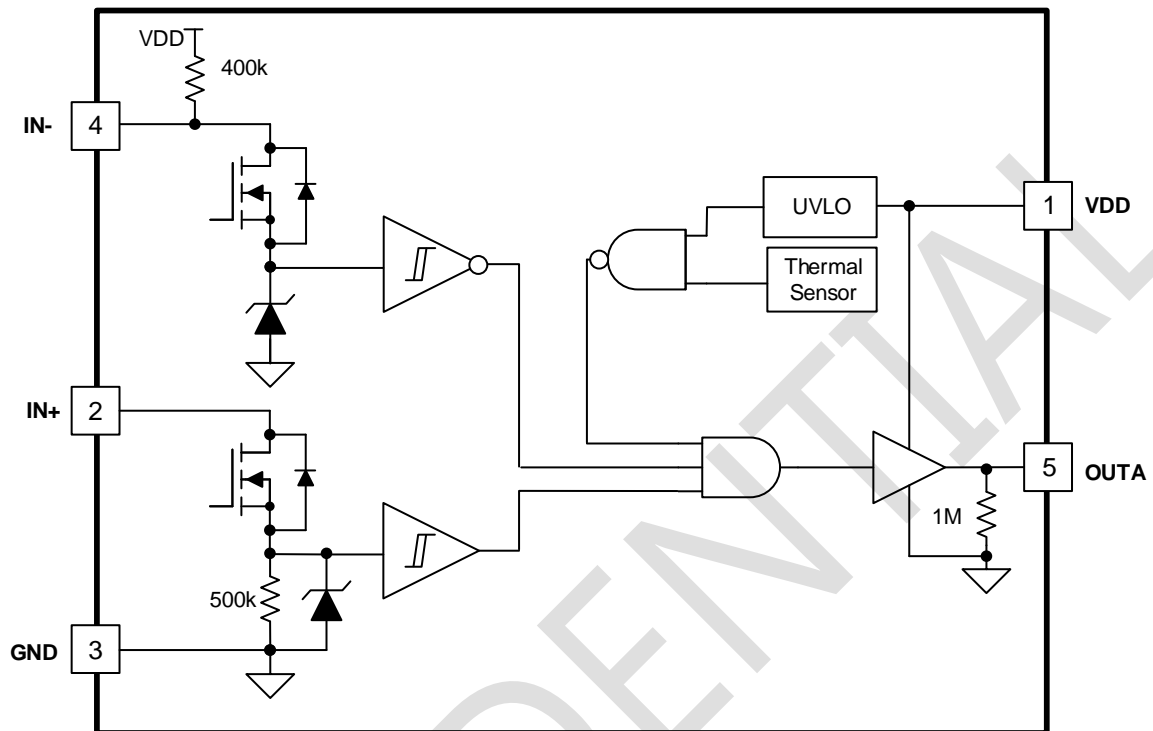

Figure 8. ROL Vs Frequency

CONFIDENTIAL

## FUNCTIONAL BLOCK DIAGRAM



## OPERATION

### Overview

The SCT51240 is up to 24V wide supply, single channel, high speed, low side gate driver for power MOSFET and IGBT. The SCT51240 can source and sink 4A peak current along with the minimum propagation delay 12ns from input to output. The ability to handle -5V DC input increased the driver input stage noise immunity, the 24V rail-to-rail output improves the SCT51240 output stage robustness during the switching load fast transition.

The SCT51240 features a dual-input design by implementing both inverting (IN- pin) and non-inverting (IN+ pin) configuration on the same device. Either the IN+ or IN- pin can be used to control the state of the driver output. The internal pull-up or pull-down resistors on the input pins ensure that output is held low when the input pins are in floating condition. As a result, the unused input pin must be biased properly to ensure that driver output is in enabled for normal operation. Table 1 is the device logic truth table.

Table 1: the SCT51240 Device Logic.

IN+	IN-	OUT
L	L	L
H	H	L
H	L	H
H	H	L
Floating	Any	L
Any	Floating	L

### VDD Power Supply

The SCT51240 operates under a supply voltage range between 4.5V to 24V. For the best high-speed circuit performance, two VDD bypass capacitors in parallel are recommended to prevent noise problems on supply VDD. A 0.1- $\mu$ F surface mount ceramic capacitor must be located as close as possible to the VDD to GND pins of the SCT51240. In addition, a larger capacitor (such as 1 $\mu$ F or 10 $\mu$ F) with relatively low ESR must be connected in parallel, in order to help avoid the unexpected VDD supply glitch. The parallel combination of capacitors presents a low impedance characteristic for the expected current levels and switching frequencies in the application.

### Under Voltage Lockout (UVLO)

SCT51240 device Under Voltage Lock Out (UVLO) rising threshold is typically 4.25 V with 350-mV typical hysteresis. When VDD is rising and the level is still below UVLO threshold, this circuit holds the output low regardless of the status of the inputs. The hysteresis prevents output bouncing when low VDD supply voltages have noise from the power supply. The capability to operate at low power supply voltage below 5 V, is especially suited for driving new emerging wide band gap power device like GaN. For example, during power up, the driver output remains low until the VDD voltage reaches the UVLO threshold. The magnitude of the OUT signal rises with VDD until steady state VDD reached.

The non-inverting operation in Figure 9 shows that the output remains low until the UVLO threshold reached, and then the output is in-phase with the input.



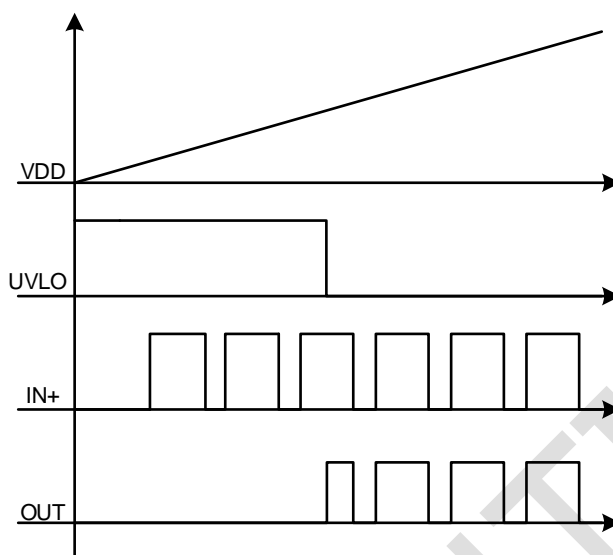

Figure 9 SCT51240 Output Vs VDD

### Input Stage

The input of SCT51240 is compatible on both TTL logic that is independent of the VDD supply voltage. With typically high threshold = 2.1 V and typically low threshold = 1.1 V, the logic level thresholds are conveniently driven by PWM control signals derived from 3.3-V and 5-V digital power-controller devices. Wider hysteresis offers enhanced noise immunity compared to traditional TTL logic implementations, where the hysteresis is typically less than 0.5 V. SCT51240 also features tight control of the input threshold voltage that ensures stable operation across temperature. The very low input capacitance on the input pins increases switching speed and reduces the propagation delay.

The SCT51240 features a dual-input configuration with two input pins available to control the state of the output. The user has the flexibility to configure the device by using either a non-inverting input pin (IN+) or an inverting input pin (IN-). The state of the output pin is dependent on the bias on both the IN+ and IN- pins. Refer to the input/output logic truth table (Table 1) and the Typical Application Diagrams Figure 11. When any of the input pin is in a floating condition, the driver output is held low state to guarantee the system robustness. There is a 500kOhm ground pull-down resistor on IN+ pin and a 400kOhm VDD pull-up resistor on IN- pin. To achieve the proper output, the IN+ and IN- pin must be properly biased.

1. To configure the SCT51240 as a non-inverting driver, apply the PWM input signal on IN+ pin and bias the IN- pin with ground or VDD, where the IN- pin can be used as an enable pin.
2. To configure the SCT51240 as an inverting driver, apply the PWM input signal on IN- pin and bias the IN+ pin can be used as an enable pin, where the IN+ can be used as an enable pin.

### Output Stage

The SCT51240 output stage features the pull up structure with P-type MOSFET PM1 and N-type MOSFET NM1 in parallel, as shown in Figure 10. PM1 provides the pull up capability when OUT approaches VDD and the NM1 holds off state, which guarantees the driver output is up to VDD rail. The measurable on-resistance  $R_{OH}$  in steady state is the conduction resistance of PM1. NM1 provides a narrow instant peak sourcing current up to 4A to eliminate the turn on time and delay. During the output turn on transition, the equivalent hybrid pull on transient resistance is  $1.5 \times R_{OL}$ , which is much lower than the  $R_{OH}$ .

The N-type MOSFET NM2 composes the output stage pull down structure; the  $R_{OL}$  is the DC measurement and represents the pull down impedance. The output stage of SCT51240 provides rail-to-rail operation, and is able to supply 4A sourcing and 4A sinking current. The presence of the MOSFET-body diodes also offers low impedance to switching overshoots and undershoots. The outputs of the dual channel drivers are designed to withstand 500-

# SCT51240

mA reverse current without either damage to the device or logic malfunction.

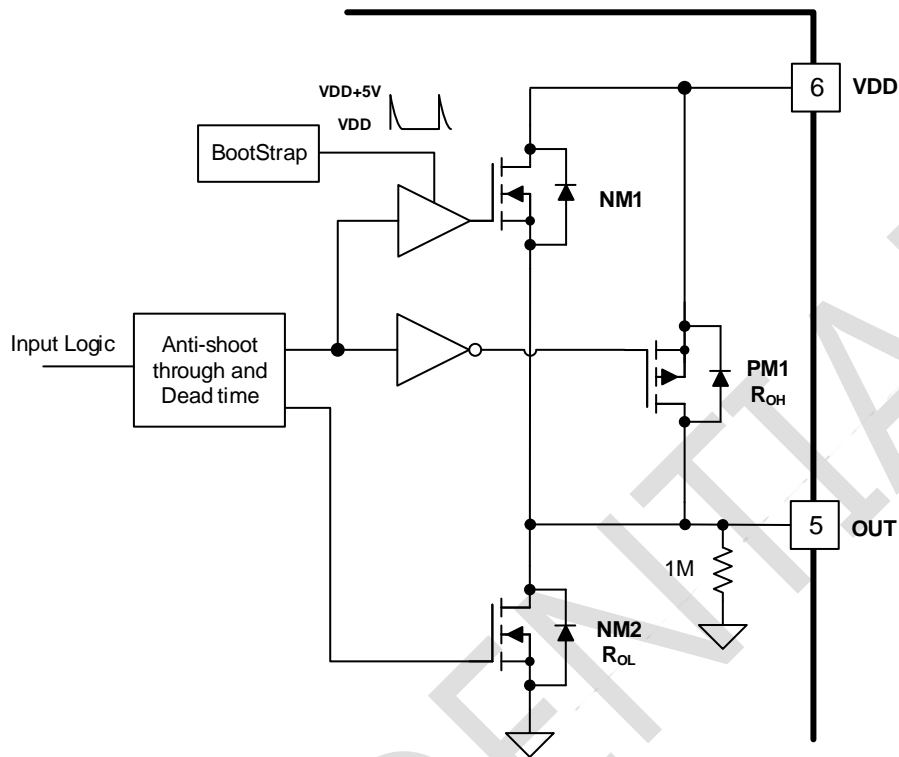

Figure 10 SCT51240 Output Stage

## Thermal Shutdown

Once the junction temperature in the SCT51240 exceeds 170° C, the thermal sensing circuit stops switching until the junction temperature falling below 145° C, and the device restarts. Thermal shutdown prevents the damage on device during excessive heat and power dissipation condition.

## APPLICATION INFORMATION

### Typical Application

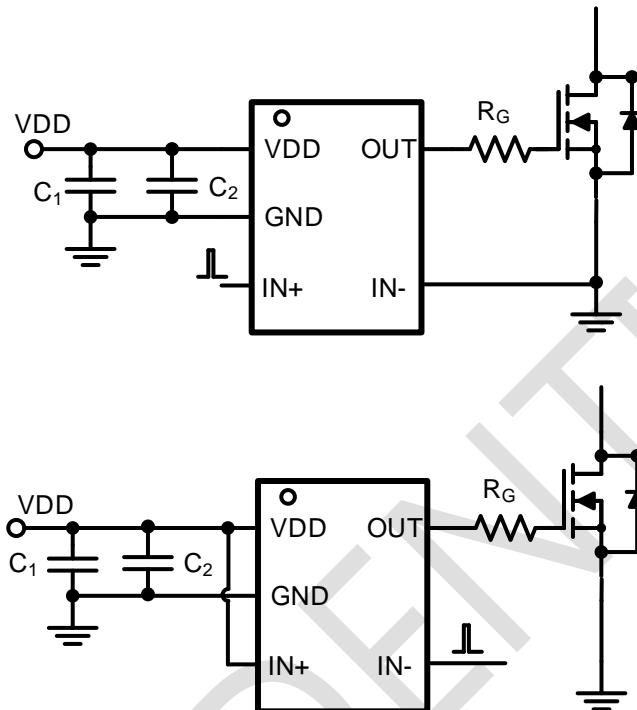

Figure 11. Single Channel Driver Non-Inverting and Inverting Application

### Driver Power Dissipation

Generally, the power dissipated in the SCT51240 depends on the gate charge required of the power device ( $Q_g$ ), Switching frequency, and use of external gate resistors. The SCT51240 features very low quiescent currents and internal logic to eliminate any shoot-through in the output driver stage, their effect on the power dissipation within the gate driver is negligible.

For the pure capacitive load, the power loss of SCT51240 is:

$$P_G = C_{Load} * V_{DD}^2 * f_{sw} \quad (1)$$

Where

- $V_{DD}$  is supply voltage
- $C_{Load}$  is the output capacitance
- $f_{sw}$  is the switching frequency

For the switching load of power MOSFET, the power loss of the driver is shown in equation (1), where charging a capacitor is determined by using the equivalence  $Q_g = C_{LOAD}V_{DD}$ . The gate charge includes the effects of the input capacitance plus the added charge needed to swing the drain voltage of the power device as it switches between the ON and OFF states. Manufacturers provide specifications that provide the typical and maximum gate charge, in nC, to switch the device under specified conditions.

# SCT51240

$$P_G = Q_g * V_{DD} * f_{SW} \tag{2}$$

Where

- $Q_g$  is the gate charge of the power device
- $f_{sw}$  is the switching frequency
- $V_{DD}$  is the supply voltage

If  $R_G$  applied between driver and gate of power device to slow down the power device transition, the power dissipation of the driver shows as below:

$$P_G = \frac{1}{2} * Q_g * V_{DD} * f_{SW} * \left( \frac{R_{OL}}{R_{OL} + R_G} + \frac{R_{OH}}{R_{OH} + R_G} \right) \tag{3}$$

Where

- $R_{OH}$  is the equivalent pull up resistance of SCT51240
- $R_{OL}$  is the pull down resistance of SCT51240
- $R_G$  is the gate resistance between driver output and gate of power device.

## Application Waveforms

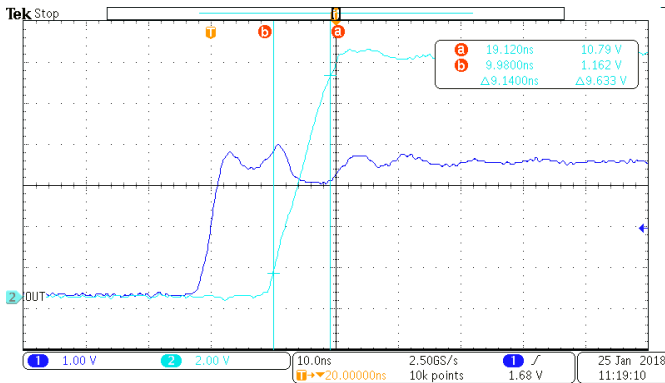

Figure 12. IN+ Switching ON

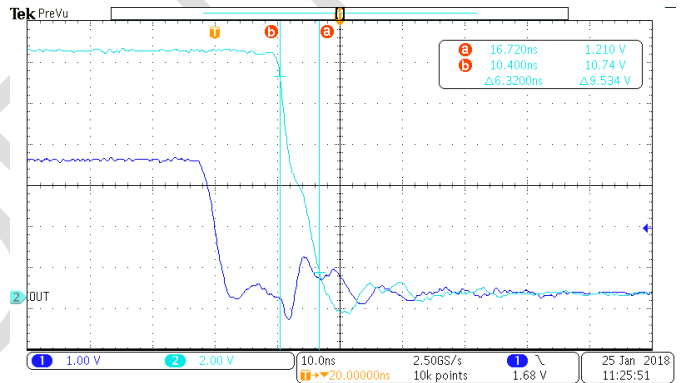

Figure 13. IN+ Switching OFF

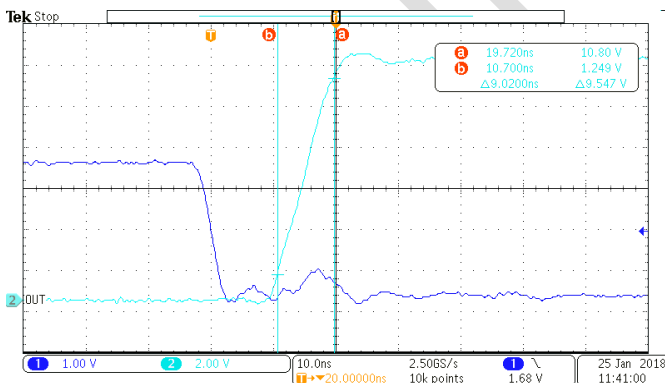

Figure 14. IN- Switching ON

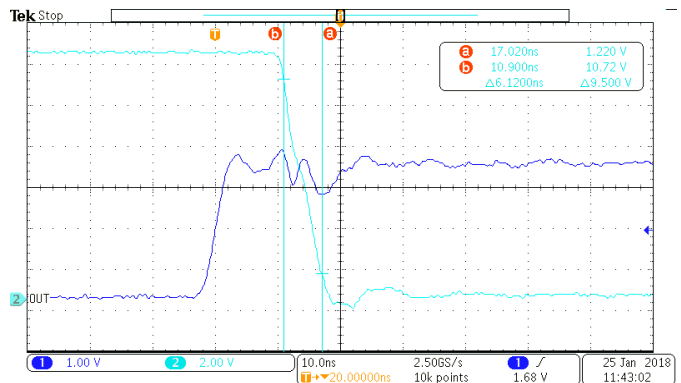

Figure 15. IN- Switching OFF

## Layout Guideline

The SCT51240 provides the 4A output driving current and features very short rising and falling time at the power device gate. The high di/dt causes driver output unexpected ringing when the driver output loop is not minimized. The regulator could suffer from malfunction and EMI noise problems if the power device gate has serious ringing. Below are the layout recommendations with using SCT51240 and Figure 16 is the layout example.

Put the SCT51240 as close as possible to the power device and minimize the gate driving loop including the driver output and power device gate. The power supply decoupling capacitors needs to be close to the VDD pin and GND pin to reduce the supply ripple.

Star-point grounding is recommended to minimize noise coupling from one current loop to the other. The GND of the driver connects to the other circuit nodes such as source of power MOSFET or ground of PWM controller at single point. The connected paths must be as short as possible to reduce parasitic inductance. A ground plane is to provide noise shielding and thermal dissipation as well.

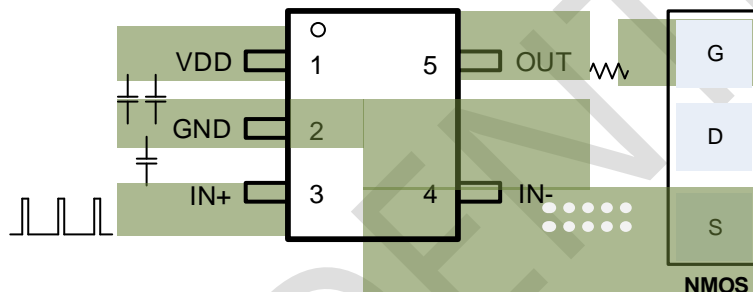

Figure 16. SCT51240 PCB Layout Example

## Thermal Considerations

The maximum IC junction temperature should be restricted to 170°C under normal operating conditions. Calculate the maximum allowable dissipation,  $P_{D(max)}$ , and keep the actual power dissipation less than or equal to  $P_{D(max)}$ . The maximum-power-dissipation limit is determined using Equation (4).

$$P_{D(MAX)} = \frac{150 - T_A}{R_{\theta JA}} \quad (4)$$

where

- $T_A$  is the maximum ambient temperature for the application.
- $R_{\theta JA}$  is the junction-to-ambient thermal resistance given in the Thermal Information table.

The real junction-to-ambient thermal resistance  $R_{\theta JA}$  of the package greatly depends on the PCB type, layout, and environmental factor. Soldering the ground pin to a large ground plate enhance the thermal performance. Using more vias connects the ground plate on the top layer and bottom layer around the IC without solder mask also improves the thermal capability.

# SCT51240

## PACKAGE INFORMATION

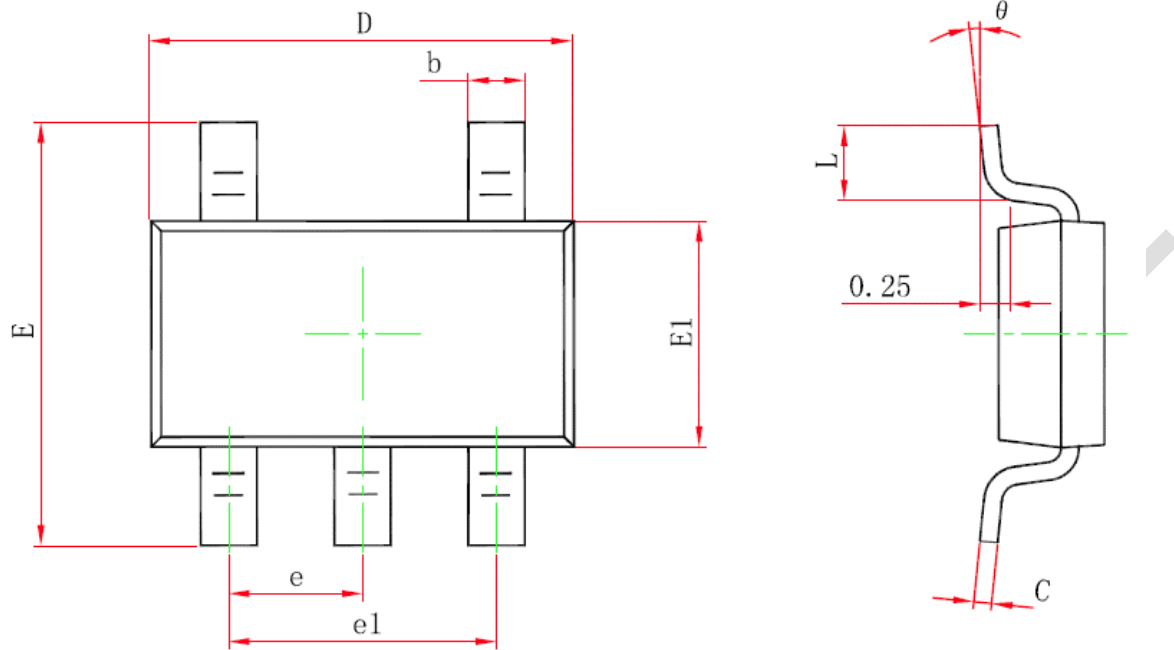

TOP VIEW

BOTTOM VIEW

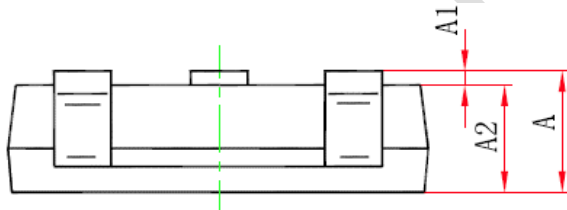

SIDE VIEW

SYMBOL	Unit: Millimeter		
	MIN	TYP	MAX
A	---	---	0.9
A1	0.02	---	0.09
A2	0.7	---	0.8
b	0.35	---	0.5
c	0.08	---	0.2
D	2.82		3.02
E	2.65		2.95
E1	1.6		1.7
e	0.95 (BSC)		
e1	1.90 (BSC)		
L	0.3		0.6
e	0°		8°

### NOTE:

1. Drawing proposed to be made a JEDEC package outline MO-220 variation.
2. Drawing not to scale.
3. All linear dimensions are in millimeters.
4. Thermal pad shall be soldered on the board.
5. Dimensions of exposed pad on bottom of package do not include mold flash.
6. Contact PCB board fabrication for minimum solder mask web tolerances between the pins.



# SCT51240

## TYPICAL APPLICATION

SCT52240 Typical Application

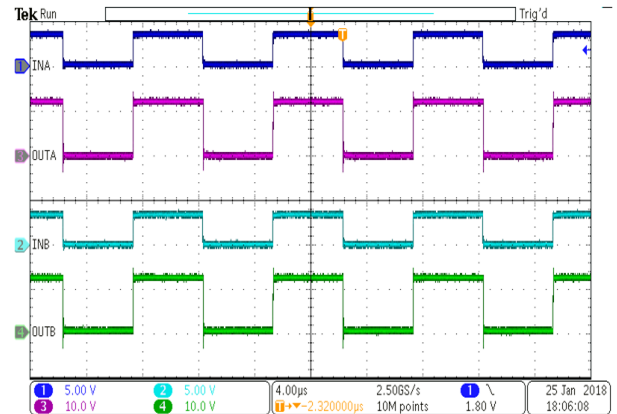
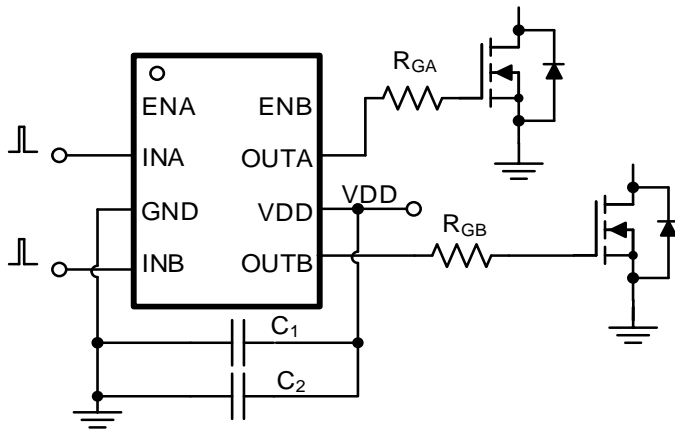

## RELATED PARTS

PART NUMBERS	DESCRIPTION	COMMENTS
<b>SCT52240</b>	Up to 24V Supply, 4-A Dual Channel High Speed Low Side Driver	<ul style="list-style-type: none"> <li>Stackable Output Application</li> <li>-5V Input Capability</li> </ul>

**NOTICE:** The information in this document is subject to change without notice. Users should warrant and guarantee the third party Intellectual Property rights are not infringed upon when integrating Silicon Content Technology (SCT) products into any application. SCT will not assume any legal responsibility for any said applications