

Schottky Barrier Diode

SD103AL/SD103BL/SD103CL

FEATURES

- Low Forward Voltage Drop.
- Guard Ring Construction For Transient Protection.
- Negligible Reverse Recovery Time.
- Low Reverse Capacitance.
- Non-Halogen.



Lead-free

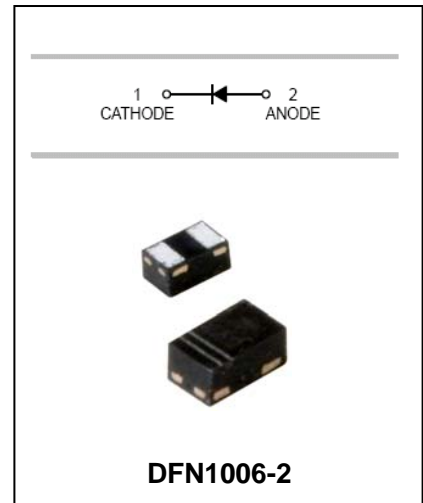

APPLICATIONS

- Schottky barrier switching.

ORDERING INFORMATION

Type No.	Marking	Package Code
SD103AL	S4	DFN1006-2
SD103BL	S5	DFN1006-2
SD103CL	S6	DFN1006-2

MAXIMUM RATING @ Ta=25°C unless otherwise specified

Parameter	Symbol	SD103AL	SD103BL	SD103CL	Unit
Peak Repetitive Peak reverse voltage	V_{RR}				
Working Peak DC Reverse Voltage	V_{RWM} V_R	40	30	20	V
RMS Reverse Voltage	$V_{R(RMS)}$	28	21	14	V
Forward Continuous Current	I_F	350			mA
Repetitive Peak Forward Current @t≤1.0s	I_{FRM}	1.5			A
Power Dissipation	P_d	200			mW
Thermal Resistance Junction to Ambient	$R_{\theta JA}$	300			°C/W
Storage temperature	T_{stg}	-65 to +125			°C

Schottky Barrier Diode

SD103AL/SD103BL/SD103CL

ELECTRICAL CHARACTERISTICS @ Ta=25°C unless otherwise specified

Parameter	Symbol	Min.	Typ.	Max.	Unit	Conditions
Reverse Breakdown Voltage	SD103AL SD103BL SD103CL	40 30 20			V	$I_R=10\mu A$ $I_R=10\mu A$ $I_R=10\mu A$
Forward voltage	V_F			0.37 0.60	V	$I_F=20mA$ $I_F=200mA$
Reverse current	SD103AL SD103BL SD103CL			5.0	μA	$V_R=30V$ $V_R=20V$ $V_R=10V$
Capacitance between terminals	C_T		50		pF	$V_R=0, f=1MHz$
Reverse Recovery Time	t_{rr}		10		ns	$I_R=I_F=200mA$ $I_{rr}=0.1 \cdot I_R, R_L=100\Omega$

TYPICAL CHARACTERISTICS @ Ta=25°C unless otherwise specified

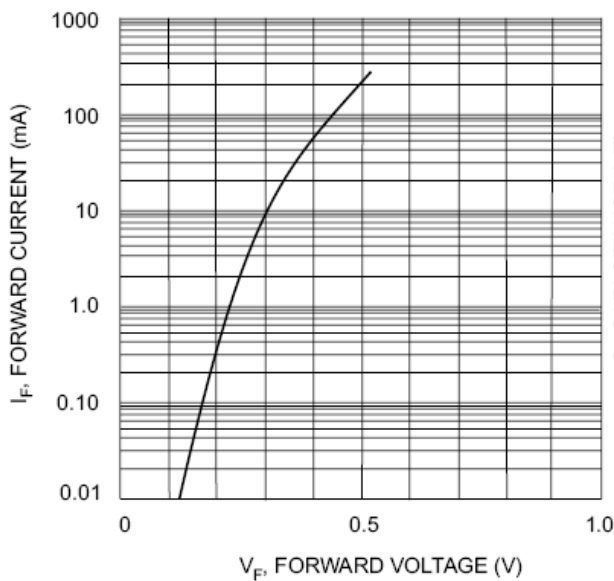

Fig. 1 Typical Forward Characteristics

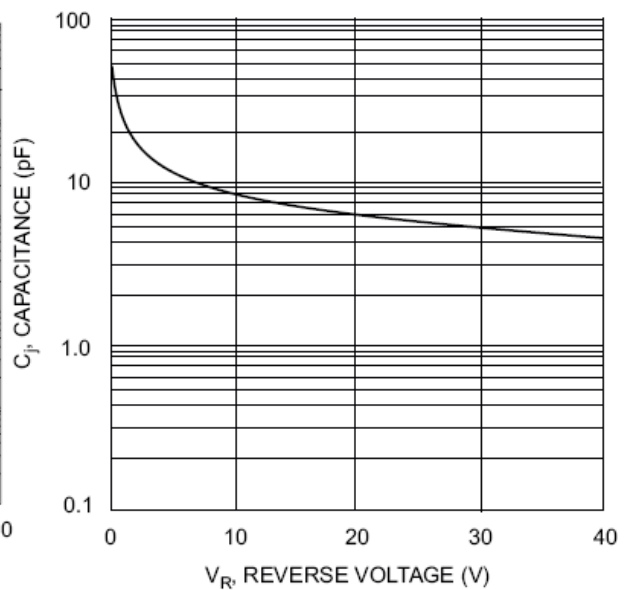

Fig. 2 Typ. Junction Capacitance vs Reverse Voltage

Schottky Barrier Diode

SD103AL/SD103BL/SD103CL

PACKAGE OUTLINE

Plastic surface mounted package

DFN1006-2

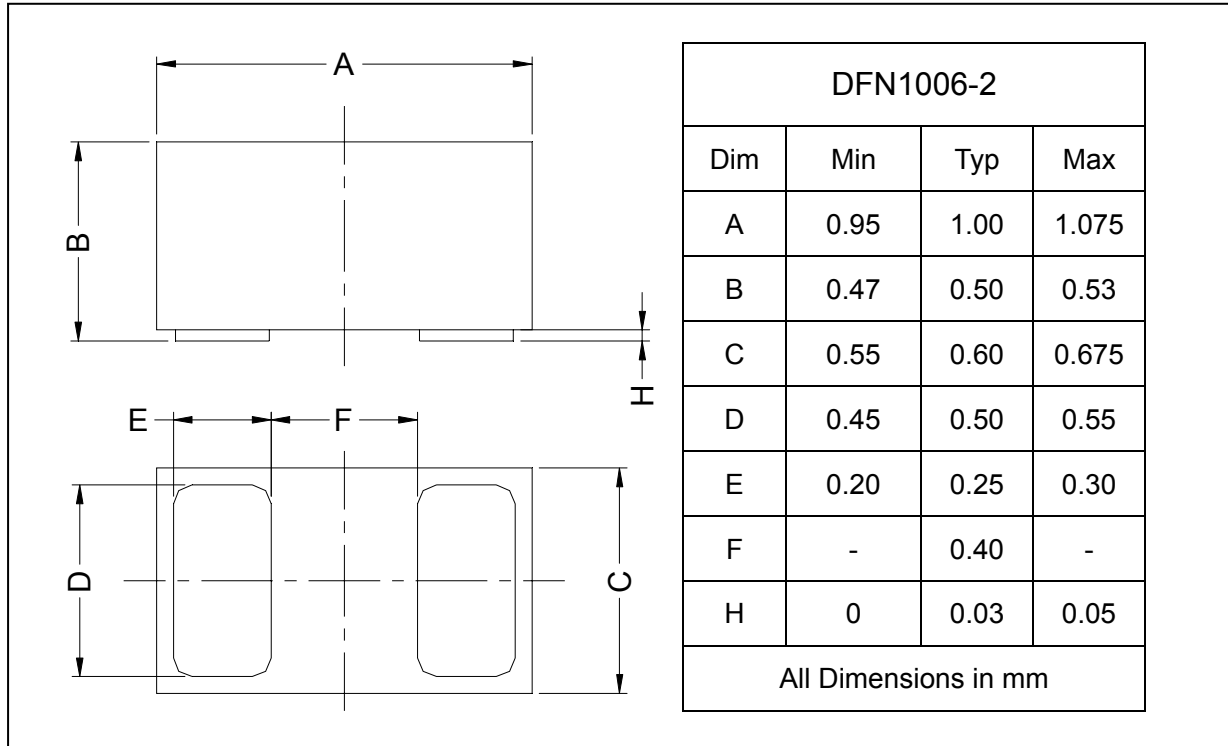

SOLDERING FOOTPRINT

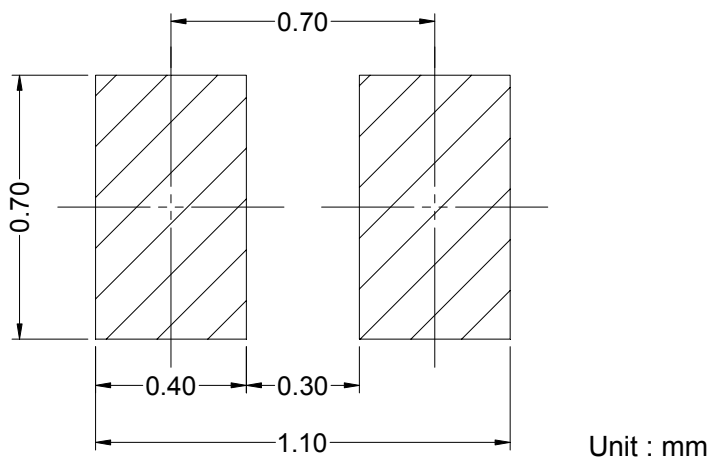

PACKAGE INFORMATION

Device	Package	Shipping
SD103AL/BL/CL	DFN1006-2	10KPCS/Tape&Reel