

SCHOTTKY BARRIER SWITCHING DIODE

SD103AW - SD103CW



**SOD-123
PLASTIC PACKAGE**

Marking: Date Code
Polarity: Cathode Band

SD103AW=S4
SD103BW=S5
SD103CW=S6

ABSOLUTE MAXIMUM RATINGS

DESCRIPTION	SYMBOL	SD103AW	SD103BW	SD103CW	UNIT
Repetitive Peak Reverse Voltage	V_{RRM}				
Working Peak Reverse Voltage	V_{RWM}	40	30	20	V
DC Blocking Voltage	V_R				
RMS Reverse Voltage	$V_{R(RMS)}$	28	21	14	V
Forward Continuous Current	$*I_{FM}$	350			mA
Non Repetitive Peak Forward Surge Current at $t \leq 1s$	I_{FSM}	1.5			A
Power Dissipation $T_a=25^{\circ}C$	$*P_D$	400			mW
Operating and Storage Temperature Range	T_j, T_{stg}	- 65 to +125			$^{\circ}C$

THERMAL RESISTANCE

Junction to Ambient in free air	$*R_{th(j-a)}$	300	$^{\circ}C/W$
---------------------------------	----------------	-----	---------------

ELECTRICAL CHARACTERISTICS ($T_a=25^{\circ}C$ unless specified otherwise)

DESCRIPTION	SYMBOL	TEST CONDITION	MIN	MAX	UNIT
Reverse Breakdown Voltage	$**V_{(BR)R}$	$I_R=100\mu A$			
		SD103AW	40		V
		SD103BW	30		V
		SD103CW	20		V
Forward Voltage	$**V_F$	$I_F=20mA$		0.37	V
		$I_F=200mA$		0.60	V
Reverse Current	$**I_R$	$V_R=30V$	SD103AW	5.0	μA
		$V_R=20V$	SD103BW	5.0	μA
		$V_R=10V$	SD103CW	5.0	μA

DYNAMIC CHARACTERISTICS

DESCRIPTION	SYMBOL	TEST CONDITION	TYP	UNIT
Total Capacitance	C_T	$V_R=0V, f=1MHz$	28	pF
Reverse Recovery Time	t_{rr}	$I_F=I_R=200mA,$ $I_{rr}=0.1 \times I_R, R_L=100\Omega$	10	ns

*Mounted on FR-4 board with recommended pad layout
**Short duration test pulse used to minimize self heating effect

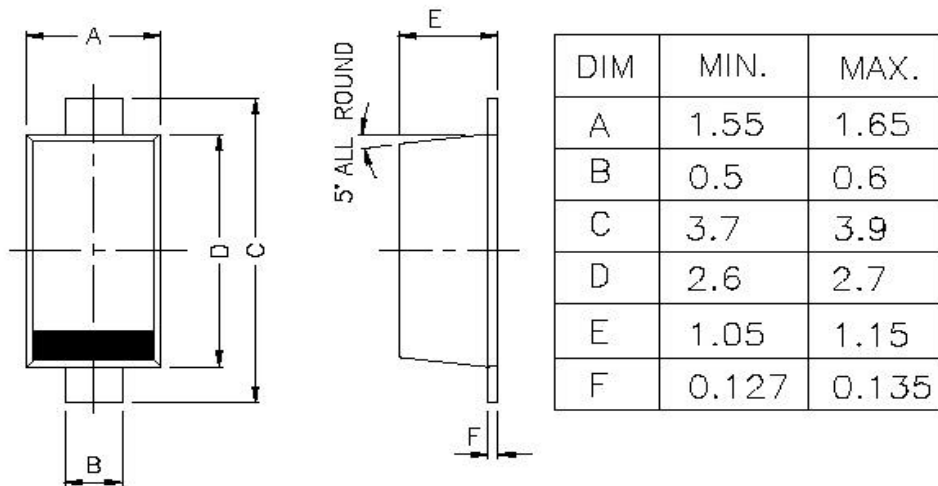
PACKAGE SOD-123 FL

All dimensions are in mm

CATHODE IS MARKED BY BAND

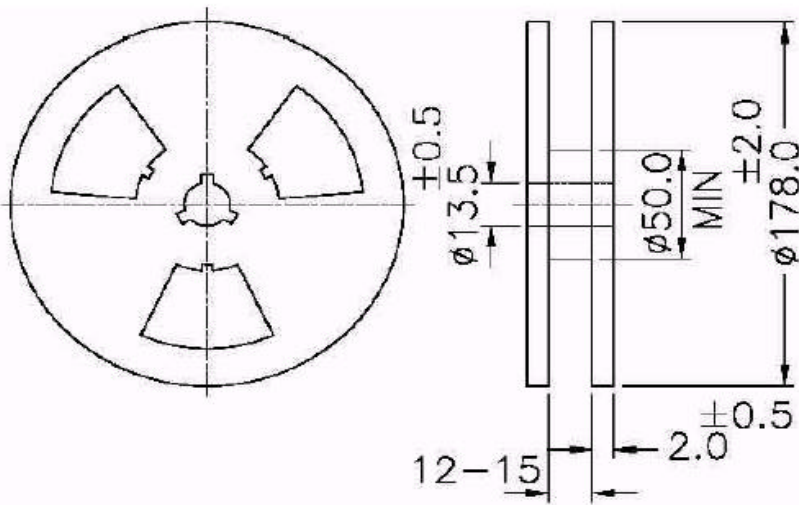

ALL DIMENSIONS ARE IN mm
 REEL \varnothing 178 mm (7")
 3000 Pcs / REEL

Component Disposal Instructions

1. CDIL Semiconductor Devices are RoHS compliant, customers are requested to please dispose as per prevailing Environmental Legislation of their Country.
2. In Europe, please dispose as per EU Directive 2002/96/EC on Waste Electrical and Electronic Equipment (WEEE).

Disclaimer

The product information and the selection guides facilitate selection of the CDIL's Semiconductor Device(s) best suited for application in your product(s) as per your requirement. It is recommended that you completely review our Data Sheet(s) so as to confirm that the Device(s) meet functionality parameters for your application. The information furnished on the CDIL Web Site/CD are believed to be accurate and reliable. CDIL however, does not assume responsibility for inaccuracies or incomplete information. Furthermore, CDIL does not assume liability whatsoever, arising out of the application or use of any CDIL product; neither does it convey any license under its patent rights nor rights of others. These products are not designed for use in life saving/support appliances or systems. CDIL customers selling these products (either as individual Semiconductor Devices or incorporated in their end products), in any life saving/support appliances or systems or applications do so at their own risk and CDIL will not be responsible for any damages resulting from such sale(s).

CDIL strives for continuous improvement and reserves the right to change the specifications of its products without prior notice.



CDIL is a registered Trademark of
Continental Device India Limited

C-120 Naraina Industrial Area, New Delhi 110 028, India.

Telephone + 91-11-2579 6150, 4141 1112 Fax + 91-11-2579 5290, 4141 1119

email@cdil.com www.cdilsemi.com