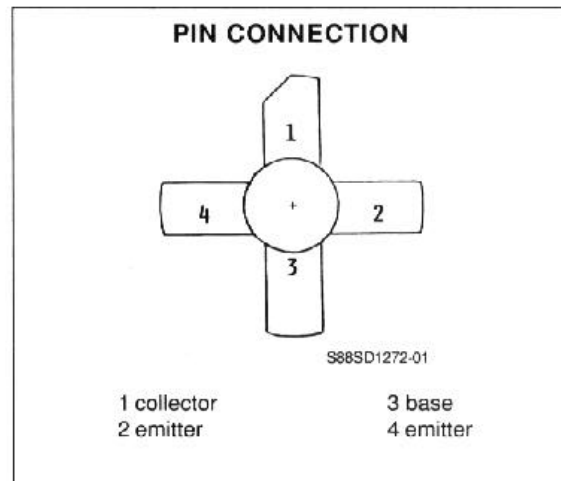
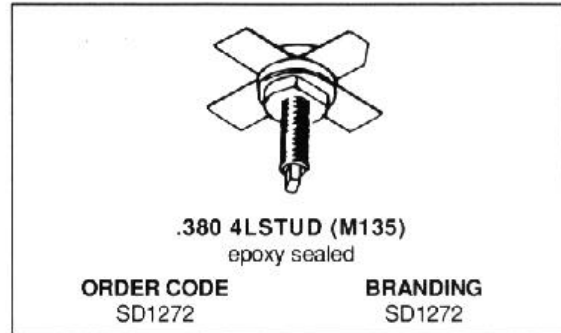

- FM CLASS C TRANSISTOR
- FREQUENCY 175MHz
- VOLTAGE 12.5V
- POWER OUT 25W
- POWER GAIN 9.2dB
- COMMON EMITTER

DESCRIPTION

The SD1272 is a 12.5V epitaxial silicon NPN planar transistor designed primarily for VHF communications. This device utilizes a nichrome aluminum metallization system to withstand infinite VSWR under severe operating conditions.

ABSOLUTE MAXIMUM RATINGS ($T_{case} = 25^{\circ}C$)

Symbol	Parameter	Value	Unit
V_{CBO}	Collector - Base Voltage	36.0	V
V_{CEO}	Collector - Emitter Voltage	18.0	V
V_{EB0}	Emitter - Base Voltage	4.0	V
I_C	Collector Current	4.0	A
P_{Tot}	Total Power Dissipation	65.0	W
T_{stg}	Storage Temperature	- 65 to + 150	$^{\circ}C$
T_j	Junction Temperature	+ 200	$^{\circ}C$

THERMAL DATA

$R_{th(j-c)}$	Junction-case Thermal Resistance	3.5	$^{\circ}C/W$
---------------	----------------------------------	-----	---------------

Note : Above parameters , ratings , limits and conditions are subject to change.

ELECTRICAL CHARACTERISTICS ($T_{case} = 25^{\circ}C$)
STATIC

Symbol	Test Conditions		Value			Unit
			Min.	Typ.	Max.	
BV_{CBO}	$I_C = 20mA$	$I_E = 0$	36.0			V
BV_{CEO}	$I_C = 50mA$	$I_B = 0$	18.0			V
BV_{EBO}	$I_E = 5mA$	$I_C = 0$	4.0			V
I_{CBO}	$V_{CB} = 15.0V$	$I_E = 0$			5.0	mA
h_{FE}	$V_{CE} = 5.0V$	$I_C = 250mA$	5.0			

DYNAMIC

Symbol	Test Conditions			Value			Unit
				Min.	Typ.	Max.	
P_O	$f = 175MHz$	$V_{CE} = 12.5V$	25.0				W
G_P	$f = 175MHz$	$V_{CE} = 12.5V$	9.2				dB
C_{OB}	$f = 1MHz$	$V_{CB} = 15.0V$			130.0		pF

Note : Above parameters , ratings , limits and conditions are subject to change.