

CMOS Photo-Electric Smoke Detector Integrated Circuit

Ordering Information

Device	Package	Order No.
SD2	16-Pin Plastic	SD2P

Features

- 6 μ A – Average Standby Current
- Minimum Cost of External Components
- 1mV Sensitivity
- 8 to 1 Increase of Sample Rate when smoke detected
- Improved Noise Rejection by multiple sampling
- Automatic LED Supervisor Alarm
- Multi-Station Input/Output Capability
- Horn Modulation Mode Control
- Piezoelectric Horn Driver
- Smoke Sensitivity Adjustable by single resistor
- Self-contained Oscillator requires only a resistor

Absolute Maximum Ratings

Supply Voltage	-0.5V to +15.0V
Input Voltage, All inputs	-0.5 to VDD +0.5V
Input Current, Any Input	\pm 10mA
Storage Temperature Range	-40°C to +100°C
Operating Free Air Temperature Range	0°C to +55°C
Power Dissipation (Package)	300mW
Continuous Output Drive Current	25mA
Lead Temperature (Soldering, 10 sec)	300°C
Relative Humidity	90%

General Description

This low power CMOS circuit is intended for use in a pulsed LED/silicon cell smoke detector system. It is designed for use in low power, battery operated, consumer applications with a minimum of external components. This device meets UL217 requirements and is available in a 16-pin plastic DIP.

Pin Configuration

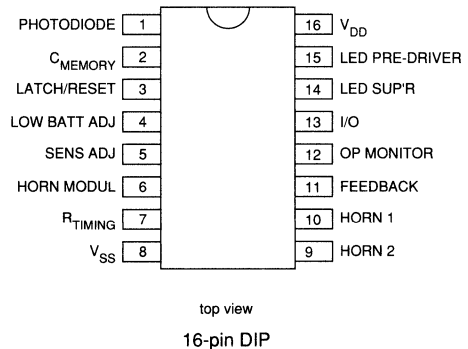

Electrical Characteristics

(w/R-(7) = 22 Meg Ω then $f_{OSC} = 485$ Hz; $T_A = 25^\circ$ C; $V_{DD} = 9V$, unless otherwise specified)

Symbol	Parameter	Min	Typ	Max	Units	Conditions
I_{IN}	Photodiode Input Leakage Current		0.01	± 1.0	nA	
V_{PD}	Photodiode Input Signal Sensitivity	0.5	0.8	1.1	mV	$C_{mem} = .05\mu F$ $C_{input} = 5pF$ $\tau_{LED} = 100\mu sec$
V_{BTH}	Low Battery Threshold Voltage	7.3	7.7	8.2	V	$R(4) = \infty$
	Horn Modulation Frequency		8		Hz	PIN 6 to V_{DD} $R(7) = 22 meg \Omega$ Smoke Detected
	Horn Modulation Duty Cycle		62.5		%	
τ_{TBL}	Low Battery/LED Supervisor Trouble Alarm Pulse Width		17		mSec	@ $f_{OSC} = 485$ Hz $R(7) = 22 Meg \Omega$
T_{TBL}	Low Battery/LED Supervisor Alarm Period		35		sec	@ $f_{OSC} = 485$ Hz $R(7) = 22 Meg \Omega$
I_{OUT}	Horn Output Current	± 25			mA	$V_O = IV$ Sink $V_O = 8V$ Source
V_{IN}	Feedback Input Voltage Range	$V_{SS} - 15$		$V_{DD} + 15$	V	Typical Min and Max. Not 100% tested
I_{OM}	Operation Monitor Output Current, Source	-2.5	-4.5		mA	$V_{OM} = 2.0V$
$I_{I/O}$	I/O Output Source Current	-4.0	-10.0		mA	$V_{I/O} = V_{DD} - 1.0$
$V_{I/O}$	Remote Alarm Trigger Voltage	$0.6 V_{DD}$			V	Sink Current 20mA typical at $V_{DD} = 4.5V$
V_{IH-ON}	LED Supervisor, upper Threshold Range	$V_{DD} - 0.8$		$V_{DD} - 0.2$	V	
V_{I-OFF}	LED Supervisor, Safe Region	$V_{DD} - 2.5$		$V_{DD} - 0.8$		
V_{IL-ON}	LED Supervisor, lower Threshold Range	$V_{DD} - 4.0$		$V_{DD} - 2.5$		
I_{LED}	LED Output Source Current	-10	-20		mA	$V_{LED} = 5V$
T_{LED}	Photodiode Sample Pulse Period (Smoke Detected)		1.0		sec	$f_{OSC} = 485$ Hz
T_{LED}	Photodiode Sample Pulse Period (Smoke Detected)		8.0		sec	$f_{OSC} = 485$ Hz $R(7) = 22 meg \Omega$
V_{DD}	Supply Voltage	7.0	9.0	10.0	V	
I_{DD}	Average Standby Supply Current		6.0	10.0	μA	$R(7) = 22 Meg \Omega$ $V_{DD} = 9.0$, Non-Alarm Mode

Pin Definition

Pin	Name	Function
1	Photodiode Input	Connect the cathode of a VTS-4085S, or equivalent, to pin 1. Connect the anode to V_{DD} . The typical allowed signal range is from V_{DD} to $V_{DD} - 1.0V$.
2	Memory Capacitor Input	The capacitor may range from 0.01 μ F to 0.05 μ F and should have low leakage. The detector sensitivity increases with increasing capacitance.
3	Latch/Reset Input	When connected to V_{DD} , the detector will latch on at the first detection of smoke alarm. When connected to V_{SS} , the alarm will not latch on detection of smoke and the low battery condition will not override the smoke alarm condition. Reset after latching is accomplished by momentarily connecting this pin to VSS until the horn silences. The Latch/Reset Input only affects the local smoke alarm response.
4	Low Battery Threshold	The nominal threshold of the battery alarm is 7.7 volts. The alarm can be raised by connecting Adjustment a resistor to ground, and lowered by connecting a resistor to V_{DD} .
5	Smoke Sensitivity Adjustment	A resistor or potentiometer to ground is used to adjust the duration of the LED pulse and thereby the Smoke Sensitivity. Pulse duration is proportional to the resistor value and varies approximately 100 μ sec per megohm.
6	Horn Modulation Control Input	When connected to V_{DD} , the Horn will pulse ON and OFF at approximately 8 Hz, with the ON time exceeding the OFF time. When connected to V_{SS} , the "Smoke" alarm will sound the Horn continuously. This control only affects the "Smoke" alarm condition.
7	Timing Resistor	A nominal resistor value of 22 megohms to V_{SS} sets the oscillator frequency to 485 Hz. Thus: <ul style="list-style-type: none"> a) The IR LED pulses every 8 seconds in standby. b) The OPERATION MONITOR LED pulses every 35 seconds in standby. c) The Horn modulation (ON-OFF) frequency is approximately 8Hz. d) The Low Battery or LED SUPERVISOR trouble pulse to the Horn will occur every 35 seconds, with 17ms duration. e) The IR LED will pulse every 1 second when smoke is detected. f) The Horn will be silenced just before each IR LED pulse for 4.2 ms, to reduce electro-magnetic interference.
8	V_{SS}	Connect this pin to circuit common, the lowest potential.
9	Horn Output 2	This terminal is connected to the brass electrode of the piezoelectric horn.
10	Horn Output 1	This pin is connected to the large silver electrode of the piezoelectric horn.
11	Horn Feedback	This pin is connected to the small silver electrode of the piezoelectric horn.
12	Operation Monitor	This output is a current source of 4mA for driving a visible LED. The LED will flash for 17ms every 35 seconds under normal conditions. The LED will be ON continuously when smoke is first detected. This occurs before the alarm sounds and indicates that the detector is in speed-up mode (1.0 second LED pulse period). This output indicates which unit is alarming in multiple station applications. When this output is used for both local LED indication and remote logic, a resistor must be placed in series with the LED.
13	Multiple Station Input/Output	This Input/Output may be connected via twisted pairs to at least 20 other units. The output goes high after at least two consecutive smoke detections have been made. The output structure allows units of different operating voltages to be connected together with no impairment of performance or excessive loading of the higher voltage units. There is an active pull-down on the output. Because of the high currents sourcing capability of the output, this pin should never be connected to V_{SS} via a low impedance path. An Input level of greater than 0.6 V_{DD} volts is required to ensure a local alarm.
14	LED Supervisor	This pin must be connected to the LED circuit as shown. Failures detected are open or shorted conditions in the LED and Driver circuit. A failure is indicated by a local pulsed trouble alarm. To defeat this feature, pin 14 must be tied to a voltage about 1.5-volts below V_{DD} , or to pin 2 in most applications.
15	LED Pre-Driver Output	This terminal can source about 13mA. The output voltage is zener clamped at approximately 6.7V and the current becomes limited. The LED current set resistor may be put in the collector circuit, below the LED, but the LED current and therefore the Sensitivity of the smoke detector will vary with supply voltage.

Pin Definition (cont.)

Pin	Name	Function
16	V_{DD}	This pin is connected to the positive battery terminal. Pin 16 should be solidly connected to the V_{DD} side of both the photodiode and the memory capacitor. A V_{DD} guard-ring type foil path around pins 1 and 2 will enhance noise immunity of the detection circuit. This circuit will operate from 7 to 10 volts, although average standby current will increase with supply voltage. Protect the integrated circuit from polarity reversal.
9,10	Alternate Driver for Electro-Mechanical Horns	When the smoke detector circuit is used to drive either a transistorized mechanical or electro-mechanical horn, the feedback (pin 11) must be connected to V_{DD} . When an alarm condition is not present, pin 10 will be at V_{DD} and pin 9 will be at V_{SS} . When an alarm condition is present, pin 10 will switch from V_{DD} to V_{SS} and pin 9 will switch from V_{SS} to V_{DD} . Both horn outputs are capable of sinking or sourcing more than 100mA at a 9-volt supply voltage. Limit the steady state on current to 25mA.
	Transistorized Mech. Horn	The control tab of the horn is connected to pin 9 and pin 10 is left open.
	Electro-Mechanical Horn	Pin 9 is connected through a resistor to the base of an NPN horn driver transistor. Pin 10 is left open.

Timing Waveform

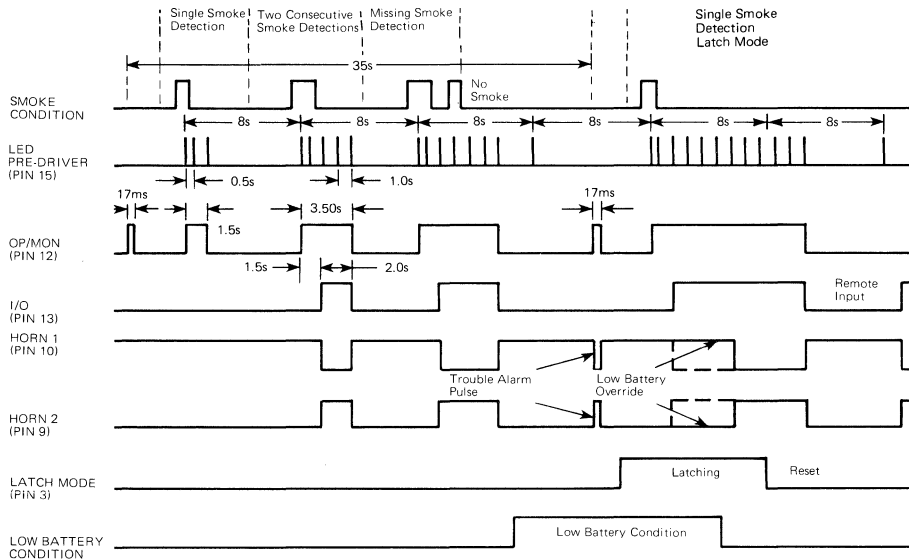

Operation

This device utilizes low power CMOS technology to provide all of the necessary functions of a battery operated, photoelectric smoke detector using a minimum of external components.

The LED PRE-DRIVER output pulses an external transistor which in turn, switches on the infrared light emitting diode at a very low duty cycle. The desired IR LED pulse period is determined by the value of the external timing resistor. The Smoke Sensitivity is adjustable through a trimmer resistor which varies the IR LED pulse width.

The light sensing element is a silicon photovoltaic cell which is held at near zero bias to minimize leakage currents. The circuit can detect signals as low as 1mV and generate an alarm. The IR LED pulse repetition rate increases when smoke is detected.

For use with a 9-volt battery, an internal zener is incorporated into the IC. When the minimum battery voltage is reached (tested during the IR LED on pulse), the output produces a short trouble alarm pulse or "blip". The horn is pulsed after every fourth IR LED pulse. When the alarm mode control is set for non-latching opera-

tion, the unit will sound a continuous alarm when smoke is detected even during low battery conditions. When the alarm mode control is set for latching operation, the low battery trouble alarm will override the smoke alarm, in accordance with UL217 specifications.

The LED SUPERVISOR tests for open or shorted conditions in the LED and Driver circuit. For either condition of the IR LED when pulsed, failure of the forward voltage to fall between two limits produces a trouble alarm pulse on the Horn after every fourth LED pulse.

The Input/Output terminal (I/O) is used to interconnect SD2 units for multiple station applications.

The OPERATION MONITOR pulses a visible LED after every fourth IR LED pulse to indicate device operation. For a local Smoke detection the LED is driven continuously.

The Horn Driver circuit self-oscillates with a piezoelectric element or enables an electro-mechanical horn when pin 11 is connected to V_{DD} .

Typical System — Non-Latching Single Station

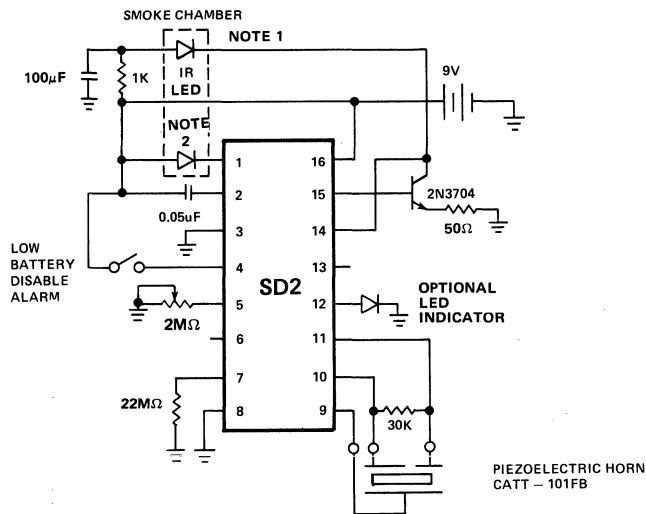

- Notes: 1. IR Diode RCA Type SG 1010A or Spectronics Type SE 5455-4
Clairex Type CLED-1
2. IR Photo detectors Vactec VTS4085

Typical Performance Curves (T_A = 25°C unless otherwise noted)

T_{LED} vs V_{DD}

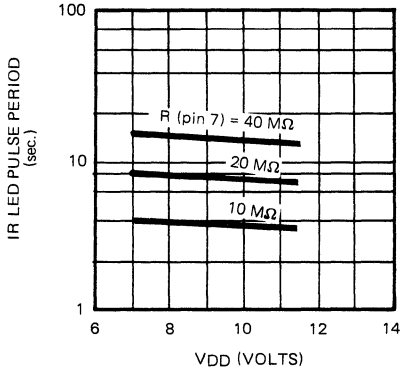

T_{PD} vs V_{DD}

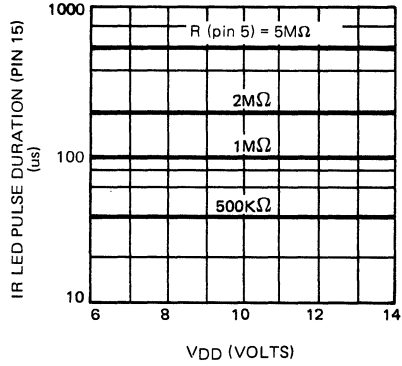

IR LED vs T_{LED} vs Oscillator

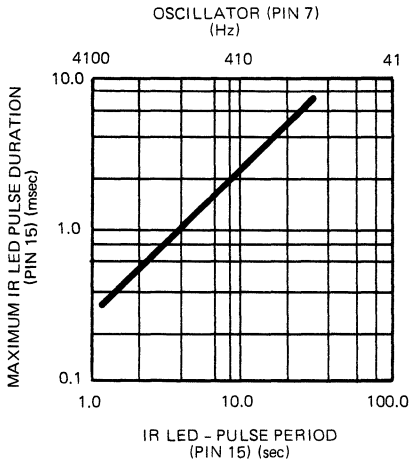

Detector Sensitivity vs C_{MEM}

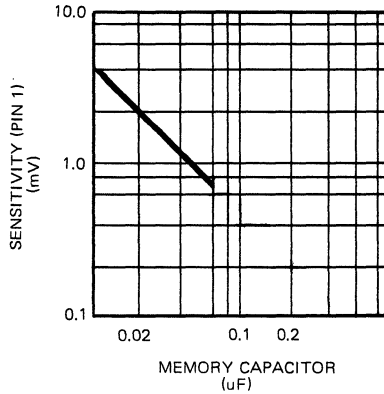

$$I_{AVG} (LED) = [(I_{OH}(15)) + I_{LED}] \frac{T_{PD}}{T_{LED}}$$

