

## SD2060P

### Product profile

High Current Density Surface Mount Ultra Low VF

Schottky Rectifier

### General description

Rectifiers 20 Amp 60V

### Features

Very low profile - typical height of 1.1 mm

Ideal for automated placement

Low forward voltage drop, low power losses

High efficiency

Low thermal resistance

Meets MSL level 1, per J-STD-020

Solder dip 260 °C max. 10 s, per JESD 22-A111

Compliant to RoHS directive 2002/95/EC and in

accordance to WEEE 2002/96/EC

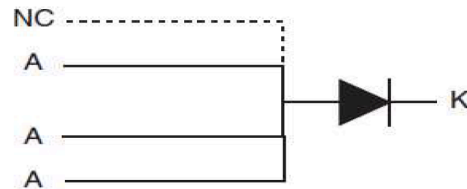
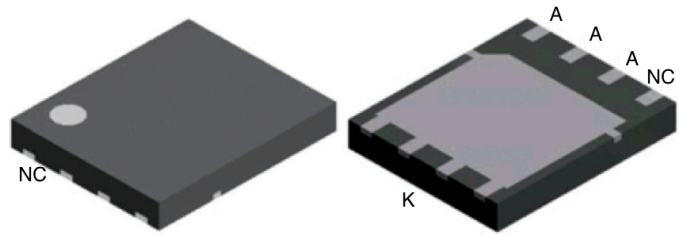

### Mechanical data

Case: **DFN 5X6**

Molding compound meets UL 94 V-0 flammability

### Maximum Ratings (Tc=25°C unless otherwise noted)

Parameter	Symbol	SD2060P	Unit
Maximum repetitive peak reverse voltage	VRRM	60	V
RMS Voltage (Max.)	VRMS	48	V
Working peak reverse voltage	VRWM	60	V
Maximum average forward rectified current	IF(AV)	20	A
Peak forward surge current	IFSM	210	A
8.3ms single half sine-wave superimposed on rated load (JEDEC Method)			
Operating junction temperature range	TJ	-55 to +150	°C
Storage temperature range	TSTG	-55 to +150	°C

### THERMAL CHARACTERISTICS

Parameter	Symbol	Value	Unit
Typical thermal resistance	RθJC	10	°C/W

- Notes: (1) Pulse test: 300 μs pulse width, 1 % duty cycle  
 (2) Pulse test: Pulse width ≤ 40

# SD2060P

## Electrical characteristics (Tc=25°C unless otherwise noted)

### OFF CHARACTERISTICS

Parameter	Symbol	Value		Unit
		Typical	Max	
Instantaneous forward voltage at IF=10A, Tj=25°C at IF=20A, Tj=25°C at IF=10A, Tj=125°C at IF=20A, Tj=125°C	VF	0.43	0.55	V
		0.48	0.58	
		0.32	-	
		0.42	0.52	
Maximum reverse current Tj=25°C	IR	200		u'A
at working peak reverse voltage Tj=125°C		100		m'A

## DEVICE MARK

SD2060P

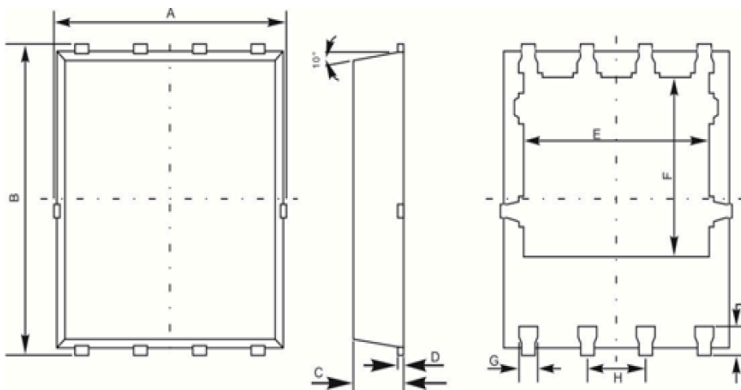

Dim.	Min.	Max.
A	5.02 typ.	
B	6.15 typ.	
C	0.80	1.05
D	0.254 Ref.	
E	3.91	4.11
F	3.38	3.58
G	0.30	0.50
H	1.27 Ref.	
I	0.45	0.65
All Dimensions in millimeter		

## SD2060P

### ■ Characteristic Curves

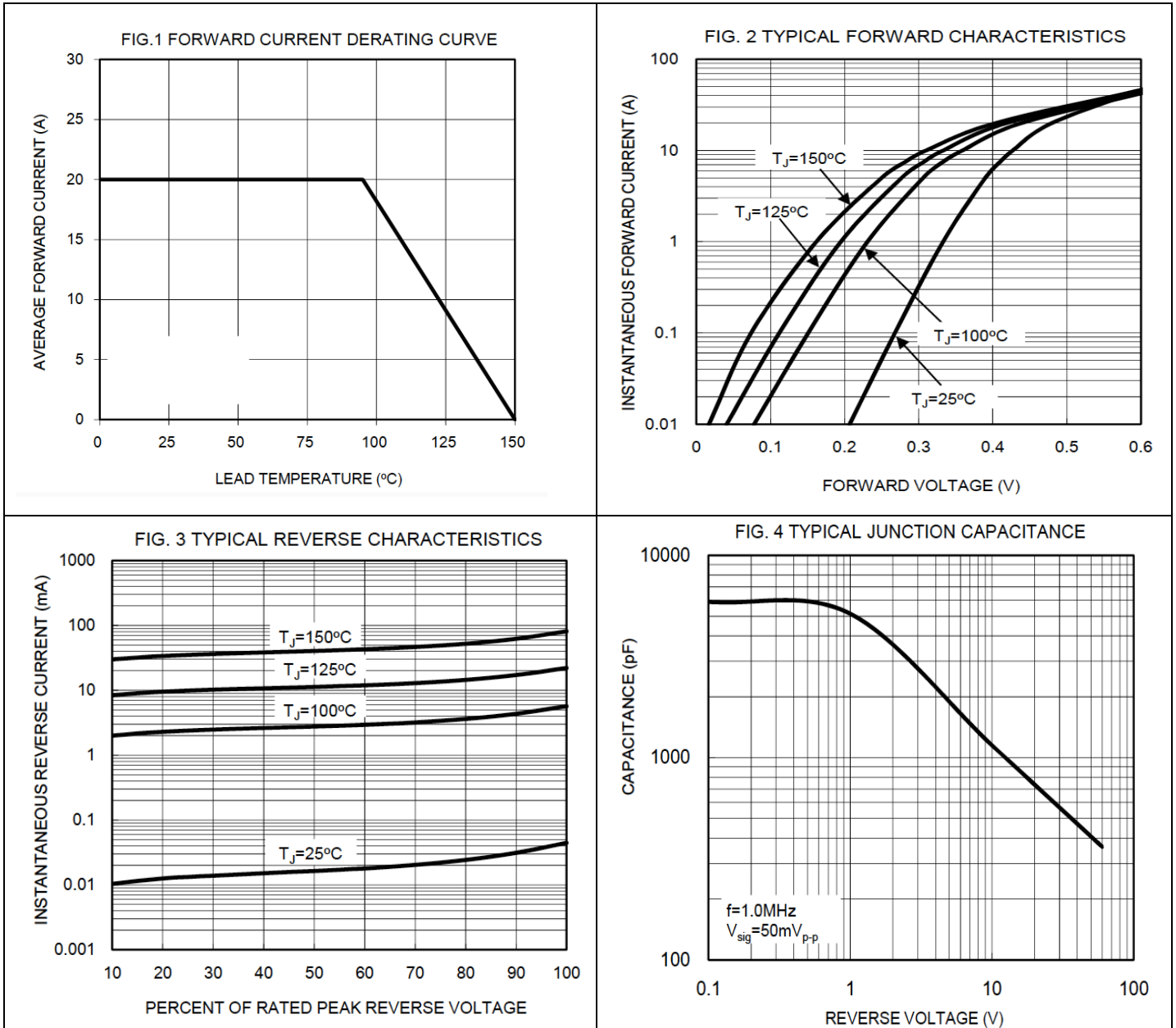

## SD2060P

### Disclaimer

ALL PRODUCT, PRODUCT SPECIFICATIONS AND DATA ARE SUBJECT TO CHANGE WITHOUT NOTICE TO IMPROVE RELIABILITY, FUNCTION OR DESIGN OR OTHERWISE.

Bruckewell Technology Inc., its affiliates, agents, and employees, and all persons acting on its or their behalf (collectively, "Bruckewell"), disclaim any and all liability for any errors, inaccuracies or incompleteness contained in any datasheet or in any other disclosure relating to any product.

Bruckewell makes no warranty, representation or guarantee regarding the suitability of the products for any particular purpose or the continuing production of any product. To the maximum extent permitted by applicable law, Bruckewell disclaims

- (i) Any and all liability arising out of the application or use of any product.
- (ii) Any and all liability, including without limitation special, consequential or incidental damages.
- (iii) Any and all implied warranties, including warranties of fitness for particular purpose, non-infringement and merchantability.

Statements regarding the suitability of products for certain types of applications are based on Bruckewell's knowledge of typical requirements that are often placed on Bruckewell products in generic applications.

Such statements are not binding statements about the suitability of products for a particular application. It is the customer's responsibility to validate that a particular product with the properties described in the product specification is suitable for use in a particular application. Parameters provided in datasheets and/or specifications may vary in different applications and performance may vary over time.

Product specifications do not expand or otherwise modify Bruckewell's terms and conditions of purchase, including but not limited to the warranty expressed therein.