

RF power transistor from the LdmoST family of N-channel enhancement-mode lateral MOSFETs

Datasheet - target specification

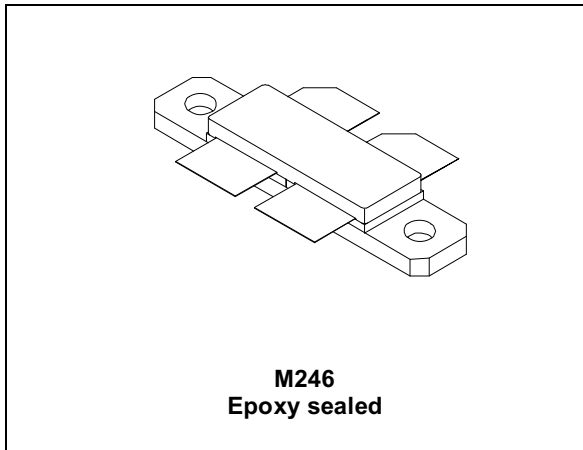

Features

- Excellent thermal stability
- Common source configuration Push-pull
- $P_{OUT} = 60\text{ W}$ with 16 dB gain @ 860 MHz
- BeO-free package

Description

The device is a common source N-channel enhancement-mode lateral field-effect RF power transistor designed for broadband commercial and industrial applications at frequencies up to 1 GHz. It is designed for high gain and broadband performance operating in common source mode at 28 V. It is ideal for applications from 1 to 1000 MHz.

Figure 1. Pin connections

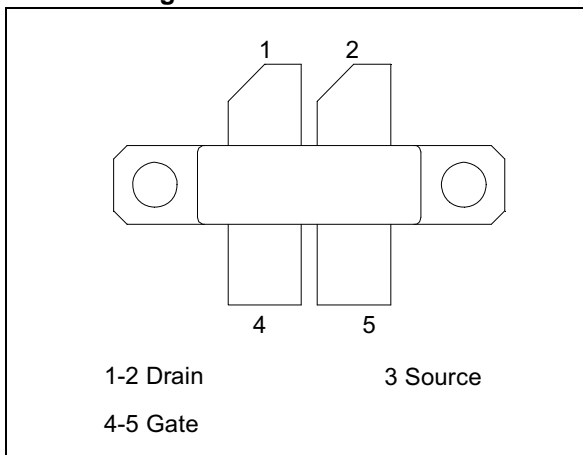

Table 1. Device summary

Order code	Package	Branding
SD56060	M246	SD56060

Contents

1	Electrical data	3
1.1	Maximum ratings	3
1.2	Thermal data	3
2	Electrical characteristics	4
2.1	Static	4
2.2	Dynamic	4
3	Impedances	5
4	Typical performances	6
5	Test circuits	9
6	Package information	11
7	Revision history	13

1 Electrical data

1.1 Maximum ratings

Table 2. Absolute maximum ratings ($T_{CASE} = 25\text{ °C}$)

Symbol	Parameter	Value	Unit
$V_{(BR)DSS}$	Drain-source voltage	65	V
V_{GS}	Gate-source voltage	± 20	V
I_D	Drain current	8	A
P_{DISS}	Power dissipation (@ $T_c = 70\text{ °C}$)	148	W
T_J	Max. operating junction temperature	200	$^{\circ}\text{C}$
T_{STG}	Storage temperature	-65 to +150	$^{\circ}\text{C}$

1.2 Thermal data

Table 3. Thermal data

Symbol	Parameter	Value	Unit
R_{thJC}	Junction - case thermal resistance	0.875	$^{\circ}\text{C/W}$

2 Electrical characteristics

$$T_{\text{CASE}} = +25\text{ }^{\circ}\text{C}$$

2.1 Static

Table 4. Static (per section)

Symbol	Test conditions		Min	Typ	Max	Unit
$V_{(\text{BR})\text{DSS}}$	$V_{\text{GS}} = 0\text{ V}$	$I_{\text{DS}} = 1\text{ mA}$	65			V
I_{DSS}	$V_{\text{GS}} = 0\text{ V}$	$V_{\text{DS}} = 28\text{ V}$			1	μA
I_{GSS}	$V_{\text{GS}} = 20\text{ V}$	$V_{\text{DS}} = 0\text{ V}$			1	μA
$V_{\text{GS(Q)}}$	$V_{\text{DS}} = 28\text{ V}$	$I_{\text{D}} = 100\text{ mA}$	3.0		5.0	V
$V_{\text{DS(ON)}}$	$V_{\text{GS}} = 10\text{ V}$	$I_{\text{D}} = 3\text{ A}$		1.3		V
G_{FS}	$V_{\text{DS}} = 10\text{ V}$	$I_{\text{D}} = 3\text{ A}$		1.8		mho
C_{ISS}	$V_{\text{GS}} = 0\text{ V}$	$V_{\text{DS}} = 28\text{ V}$		58		pF
C_{OSS}	$V_{\text{GS}} = 0\text{ V}$	$V_{\text{DS}} = 28\text{ V}$		34		pF
C_{RSS}	$V_{\text{GS}} = 0\text{ V}$	$V_{\text{DS}} = 28\text{ V}$		2.7		pF

Note: REF. 7194566A

2.2 Dynamic

Table 5. Dynamic

Symbol	Test conditions		Min	Typ	Max	Unit
P_{OUT}	$V_{\text{DD}} = 28\text{ V}$	$I_{\text{DQ}} = 100\text{ mA}$ $f = 860\text{ MHz}$	60			W
G_{PS}	$V_{\text{DD}} = 28\text{ V}$	$I_{\text{DQ}} = 100\text{ mA}$ $P_{\text{OUT}} = 60\text{ W}$ $f = 860\text{ MHz}$	14	16		dB
η_{D}	$V_{\text{DD}} = 28\text{ V}$	$I_{\text{DQ}} = 100\text{ mA}$ $P_{\text{OUT}} = 60\text{ W}$ $f = 860\text{ MHz}$	50	60		%
IMD (1)	$V_{\text{DD}} = 28\text{ V}$	$I_{\text{DQ}} = 100\text{ mA}$ $P_{\text{OUT}} = 60\text{ W PEP}$		-28		dB _C
Load mismatch	$V_{\text{DD}} = 28\text{ V}$	$I_{\text{DQ}} = 100\text{ mA}$ $P_{\text{OUT}} = 60\text{ W}$ $f = 860\text{ MHz}$ All phase angles	5:1			VSWR

Note: 1 PEP $f_1 = 860\text{ MHz}$, $f_2 = 860.1\text{ MHz}$

3 Impedances

Figure 2. Current conventions

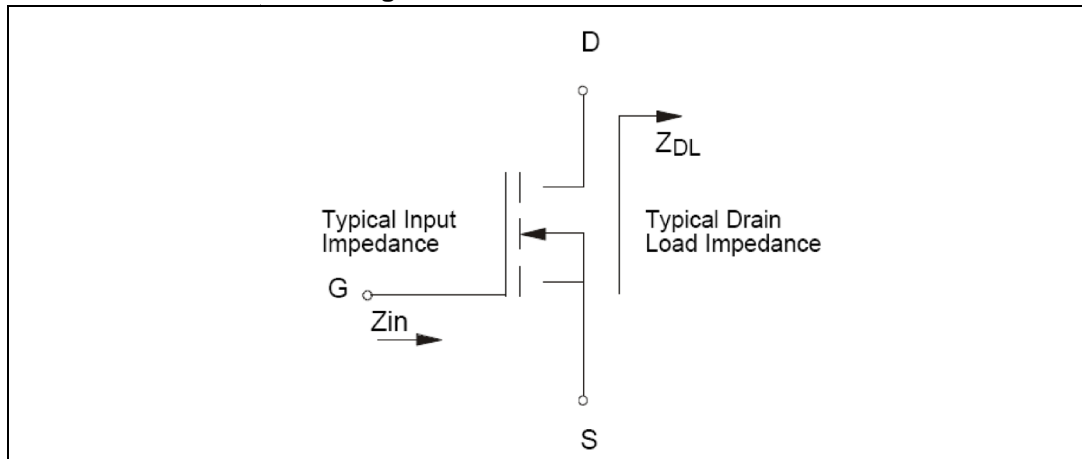
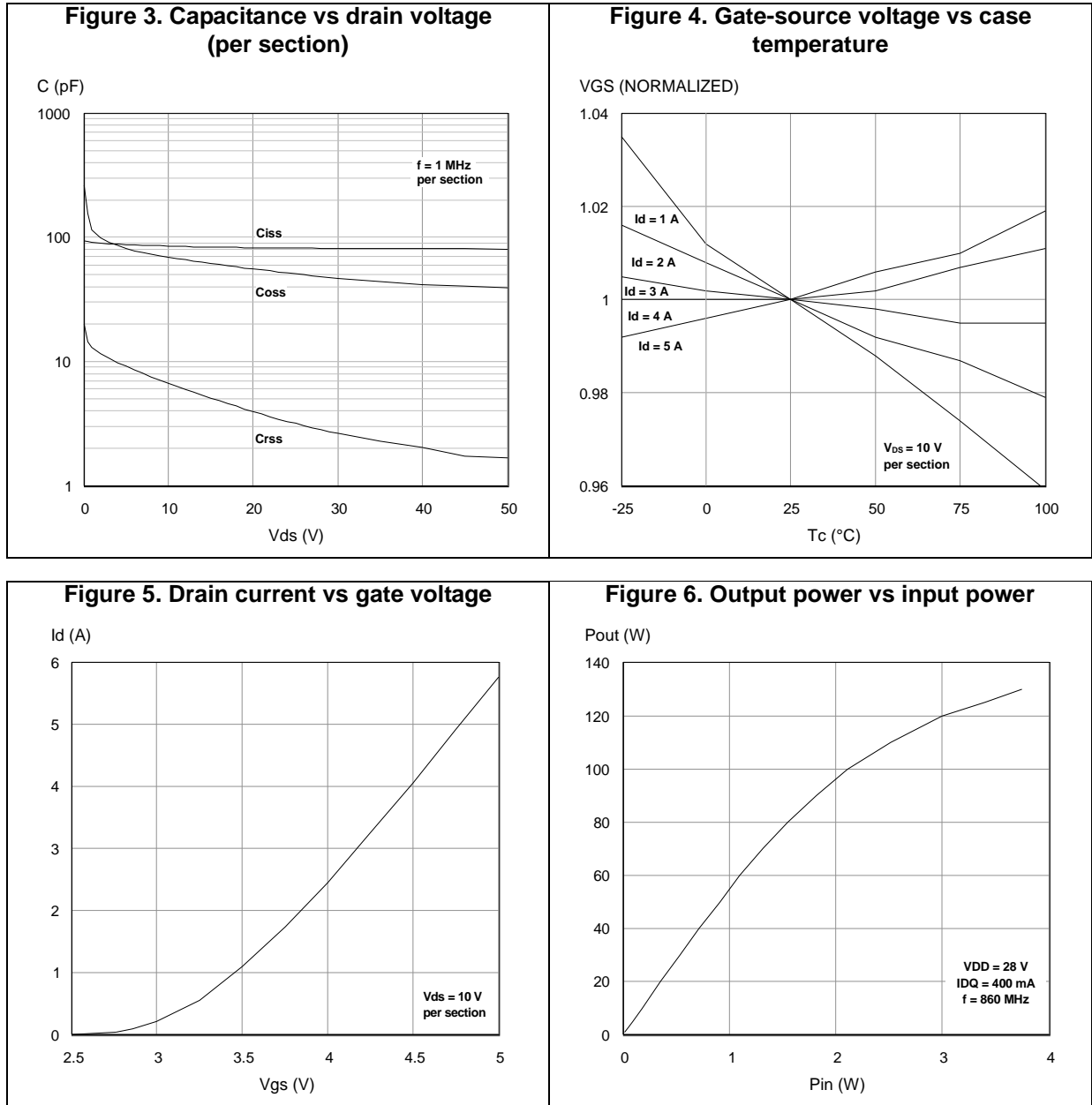

Table 6. Impedance data

Freq. (MHz)	Z_{IN} (Ω)	Z_{DL} (Ω)
860 MHz	TBD	TBD

Measured drain to drain and gate to gate respectively.

4 Typical performances



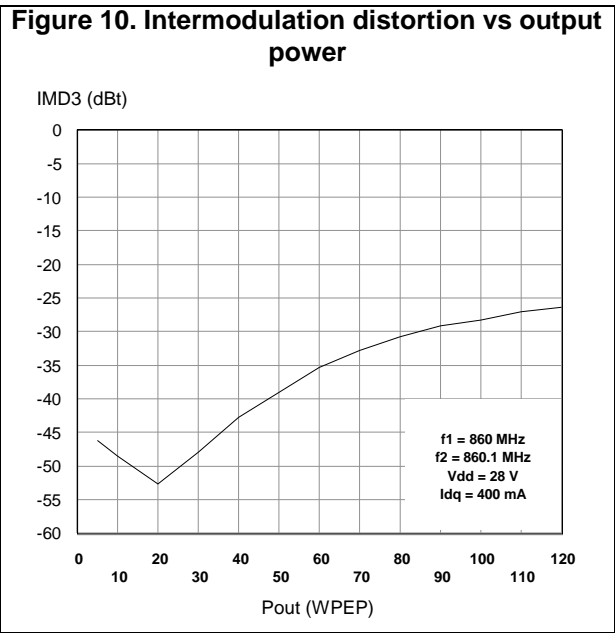
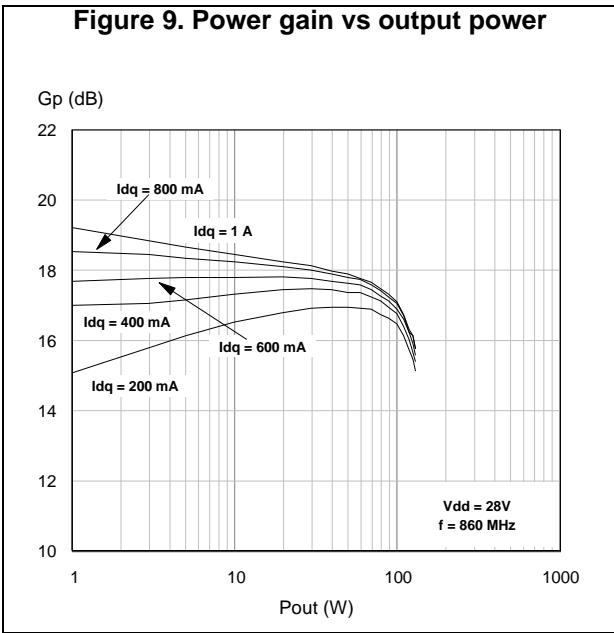
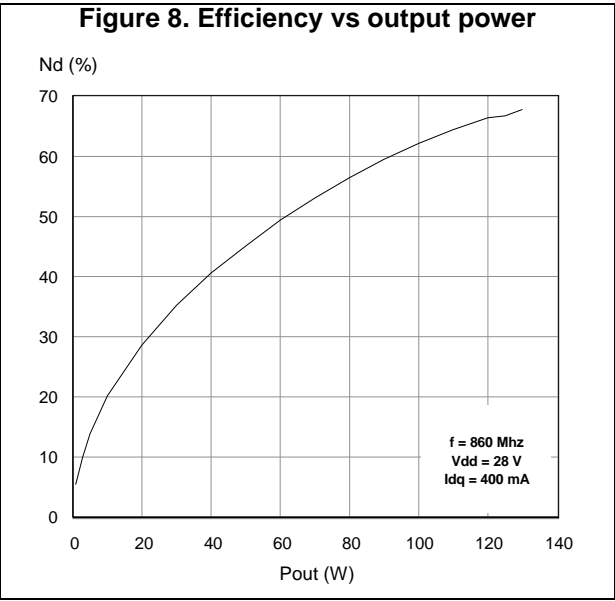
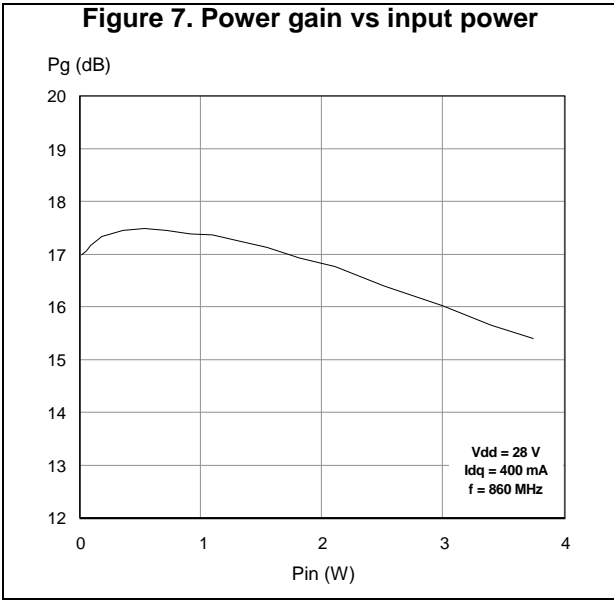

Figure 11. Output power vs drain voltage

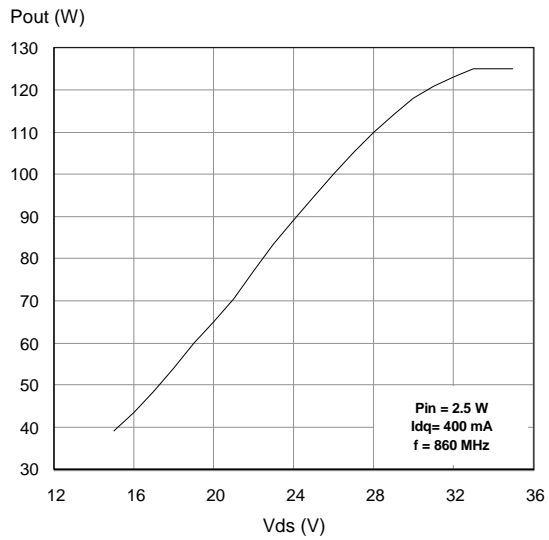

Figure 12. Output power vs bias current

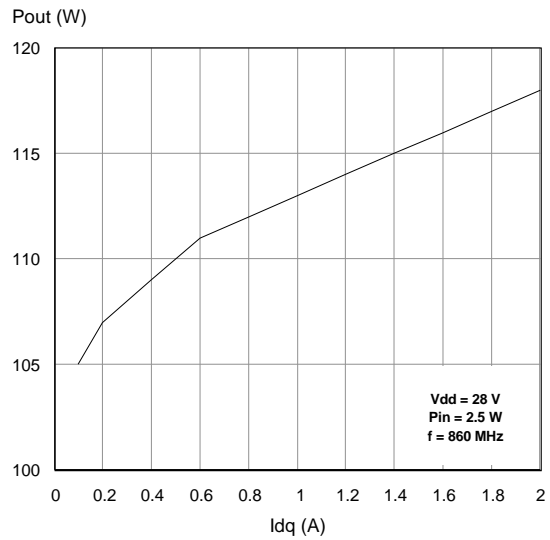
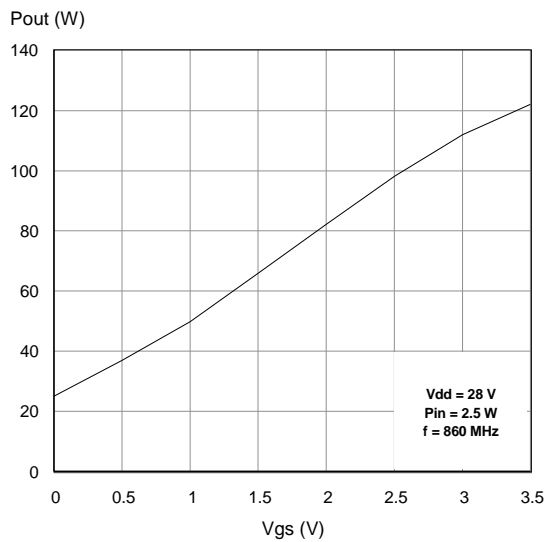
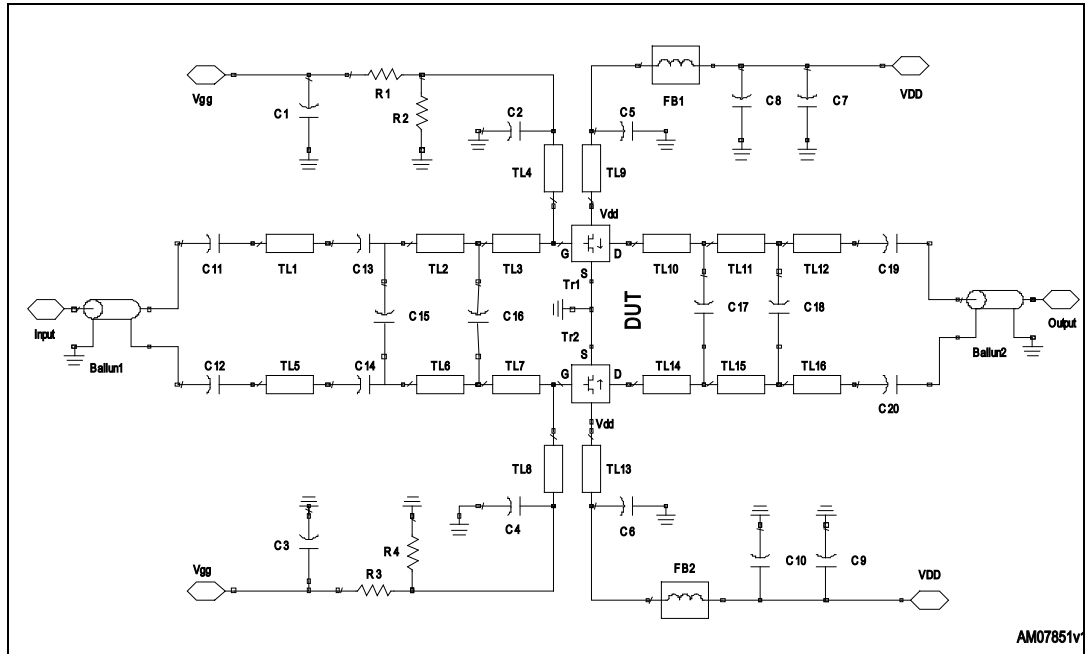

Figure 13. Output power vs gate-source voltage



5 Test circuits

Figure 14. 860 MHz test circuit schematic



- Note: 1 Dimensions at component symbols are reference for component placement.
 2 Gap between ground & transmission line = 0.056 [1.42] +0.002 [0.05] -0.000 [0.00] typ.

Table 7. Circuit component list

Item	Q.ty	Part number	Vendor	Description
R1, R3	2	CR1206-8W-130JB	VENKEL	13 Ω, 1/8 W surface mount chip resistor
R2, R4	2	CR1206-8W-122JB	VENKEL	1.2 kΩ, 1/8 W surface mount chip resistor
R5, R6	2	CR1206-8W-250JB	VENKEL	25 Ω, 1/8 W surface mount chip resistor
B1, B2	2	2743021447	FAIR-RITE CORP	Surface mount EMI shield bead
C1, C3, C7, C9	4			100 μF, 63 V electrolytic capacitor
C2, C4, C5, C6	4	ATC100B910XXXX	ATC	91 pF chip capacitor
C8, C10	2	C1812X7R501-104KNE	VENKEL	0.1 F 500 V surface mount ceramic chip capacitor
C11, C12	2	ATC100B620XXXX	ATC	62 pF chip capacitor
C13, C14	2	ATC100B151XXXX	ATC	150 pF chip capacitor
C15	1	ATC100B110XXXX	ATC	5.1 pF chip capacitor
C16	1	ATC100B7R5XXXX	ATC	7.5 pF chip capacitor
C17	1	ATC100B1R1XXXX	ATC	1.1 pF chip capacitor

Table 7. Circuit component list (continued)

Item	Q.ty	Part number	Vendor	Description
C18	1	27291PC	JOHANSON	0.8 - 8 pF giga trim variable capacitor
C19, C20	2	ATC100B101XXXX	ATC	100 pF chip capacitor
TL1, TL5				L= 0.250in [6.35mm] W=0.214in [5.44mm]
TL2, TL6				L= 0.182in [4.62mm] W=0.284in [7.21mm]
TL3, TL7				L= 0.318in [8.08mm] W=0.284in [7.21mm]
TL4, TL8, TL9, TL13				L= 2.37in [60.19mm] W=0.082in [2.08mm]
TL10, TL14				L= 0.314in [7.97mm] W=0.230in [5.84mm]
TL11, TL15				L= 0.460in [11.68mm] W=0.230in [5.84mm]
TL12, TL16				L= 0.280in [7.11mm] W=0.230in [5.84mm]
Board 3X5	1		Rogers Corp	Er=2.55 t=0.0026in h=0.030in

6 Package information

In order to meet environmental requirements, ST offers these devices in different grades of ECOPACK® packages, depending on their level of environmental compliance. ECOPACK® specifications, grade definitions and product status are available at: www.st.com. ECOPACK® is an ST trademark.

Figure 15. M246 (.230 x .650 WIDE 4/L BAL N/HERM W/FLG) package outline

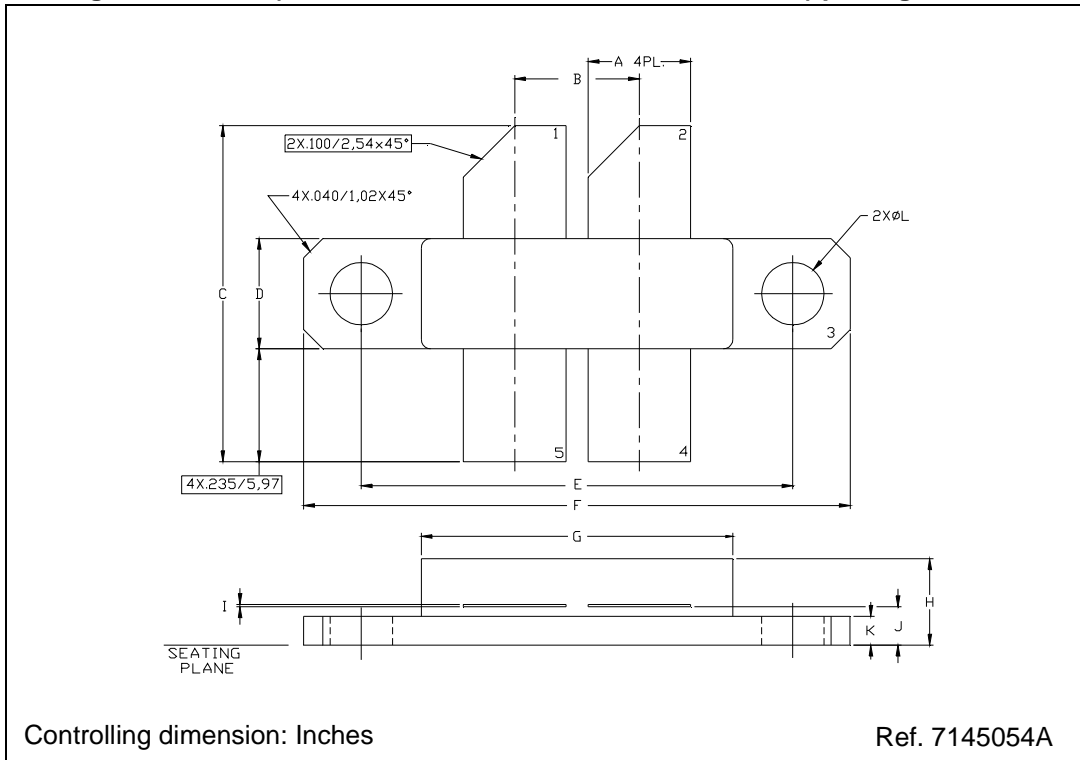

Table 8. M246 (.230 x .650 WIDE 4/L BAL N/HERM W/FLG) package mechanical data

Dim.	mm.			Inch		
	Min	Typ	Max	Min	Typ	Max
A	5.33		5.59	.210		.220
B	6.48		6.73	.255		.265
C	17.27		18.29	.680		.720
D	5.72		5.97	.225		.235
E		22.86			.900	
F	28.83		29.08	1.135		1.145
G	16.26		16.76	.640		.660
H	4.19		5.08	.165		.200
I	0.08		0.15	.003		.006
J	1.83		2.24	.072		.088
K	1.40		1.65	.055		.065
L	3.18		3.43	.125		.135

7 Revision history

Table 9. Document revision history

Date	Revision	Changes
15-Jun-2015	1	Initial release

IMPORTANT NOTICE – PLEASE READ CAREFULLY

STMicroelectronics NV and its subsidiaries ("ST") reserve the right to make changes, corrections, enhancements, modifications, and improvements to ST products and/or to this document at any time without notice. Purchasers should obtain the latest relevant information on ST products before placing orders. ST products are sold pursuant to ST's terms and conditions of sale in place at the time of order acknowledgement.

Purchasers are solely responsible for the choice, selection, and use of ST products and ST assumes no liability for application assistance or the design of Purchasers' products.

No license, express or implied, to any intellectual property right is granted by ST herein.

Resale of ST products with provisions different from the information set forth herein shall void any warranty granted by ST for such product.

ST and the ST logo are trademarks of ST. All other product or service names are the property of their respective owners.

Information in this document supersedes and replaces information previously supplied in any prior versions of this document.

© 2015 STMicroelectronics – All rights reserved