

Stepping Motor Drive IC

IMC Magnetics Corp., Western Division, proudly introduces its new SDB-520 (A) stepping-motor drive IC chip which is intended for a wide variety of applications.

This chip can control three and four phase stepping-motors in either 1, 2, or 1-2 phase excitation-mode operations.

The product is a result of our continuous effort to simplify and lower the cost of complicated circuitry previously required for this purpose. The entire logic circuit for signal processing is loaded onto a single chip in the SDB-520 (A). Therefore, it is fully operational as a driver, with only a minimum additional equipment. All you need to supply is a pulse generator, a power transistor and some direct current.

Characteristics:

- 1) Chip operates on 5V power supply.
- 2) Is able to drive three phase pulse motors in 1, 2, or 1-2 phase excitation modes.
- 3) Is able to drive four phase pulse motors in 1, 2, or 1-2 phase excitation modes.
- 4) Chip allows high level output current of up to $I_o = \pm 30\text{mA}$ ($\phi 1, \phi 2, \phi 3, \phi 4$)
- 5) Input (C_u, C_d) is designed to accommodate a high noise margin. (With built-in Schmidt trigger)
- 6) Comes with excitation "OFF" terminal.
- 7) Comes with sequence monitor.
- 8) Has line-drive functions.
- 9) Output pin ($\phi 1, \phi 2, \phi 3, \phi 4$) equipped with clamping diodes.
- 10) Equipped with output current short circuit protective circuit.

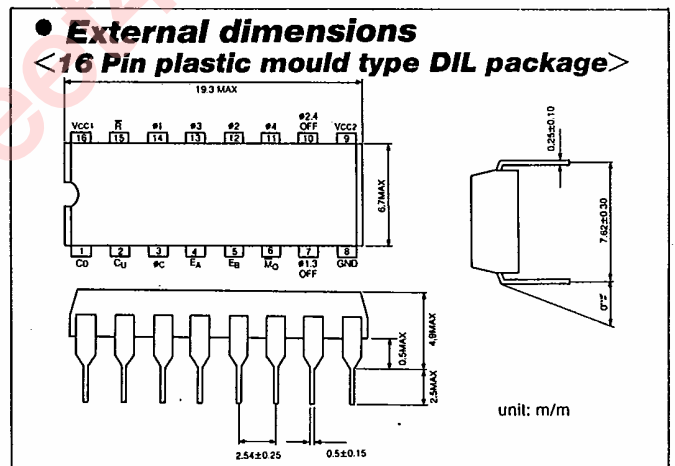

● Block diagram

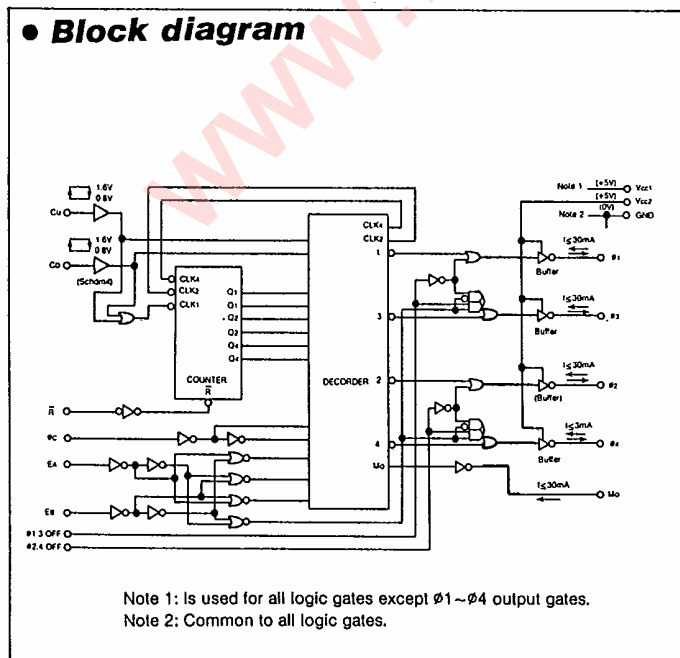

● Description of pin function

No.	SYMBOL		
1	\bar{C}_d	Input Pulse	Rotation counter clock-wise
2	C_u	Input Pulse	Rotation Clock-wise
3	ϕc	3 phase 4 phase	Phase transfer "H" 4 phase "L" 3 phase
4	E_A	Mode of Switching Pin	E_B E_A Mode
5	E_B		0 0 Line drive
			0 1 1 Phase excitation
			1' 0 2 Phase excitation
		1 1 1-2 Phase excitation	
6	\bar{M}_o	Sequence monitor	Monitor forced to "L" level upon indication of 000 on the built-in counter.
7	OFF $\phi 1-3$	Excitation switch OFF, or Line drive input	Pin $\phi 3$ is forced to "L" level regardless of sequence, when output pin $\phi 1 - \phi 2$ indicates $\phi 1 - \phi 3 = 0$
8	GND	OV connection pin for power source	
9	VCC2	Power source for output driver $\phi 1 - \phi 4$	
10	OFF $\phi 2-4$	Excitation, Switch OFF or Line drive input	Pin $\phi 1, \phi 4$ is forced to "L" level regardless of sequence, when output pins $\phi 1, \phi 4$ indicator $\phi 2, \phi 4 = 0$
11- $\phi 4, 12-\phi 2, 13-\phi 3, 14-\phi 1$			Output driver pins
15	\bar{R}	Reset input pin	
16	VCC1	Power source for logic circuit	

• **Function table:**

Input Pin								Function
E	EA	ES	ϕC	Cu	Cd	$\phi 1-3'$	$\phi 2-4$	
1	1	0	0	*	*	1	1	3 Phase motor, 1 phase excitation
1	0	1	0	*	*	1	1	3 Phase motor, 2 phase excitation
1	1	1	0	*	*	1	1	3 Phase motor, 1-2 phase excitation
1	1	0	1	*	*	1	1	4 Phase motor, 1 phase excitation
1	0	1	1	*	*	1	1	4 Phase motor, 2 phase excitation
1	1	1	1	*	*	1	1	4 Phase motor, 1-2 phase excitation
1	EA + EB = 1		1/1	$\sqrt{2}$	0	1	1	Rotation CW-ward
1	EA + EB = 1		1/1	0	$\sqrt{2}$	1	1	Rotation CCW-ward
1	EA + EB = 1		1/1	*	*	0	0	$\phi 1 = \phi 2 = \phi 3 = \phi 4 = 0$ ○
1	EA + EB = 1		1/1	*	*	0	1	$\phi 1 = \phi 3 = 0$, $\phi 2, \phi 4$ Normal op ○
1	EA + EB = 1		1/1	*	*	1	0	$\phi 2 = \phi 4 = 0$, $\phi 1, \phi 3$ Normal op ○
○	0	0	○	○	○	0	0	$\phi 1 = 0$, $\phi 3 = 1$, $\phi 2 = 0$, $\phi 4 = 1$
○	0	0	○	○	○	0	1	$\phi = 0$, $\phi 3 = 1$, $\phi 2 = 0$, $\phi 4 = 1$
○	0	0	○	○	○	1	0	$\phi = 0$, $\phi 3 = 0$, $\phi 2 = 0$, $\phi 4 = 1$
○	0	0	○	○	○	1	1	$\phi 1 = 1$, $\phi 3 = 0$, $\phi 2 = 1$, $\phi 4 = 0$
0	○	○	○	○	○	1	1	"1" 0 = "2" 0 = "4" 0 = 0 Mo = 0

NOTE)
 * mark signifies pulse flow to Cu or Cd.
 When Cu is in operation, Cd = 0 and when Cd is in operation, Cu = 0
 ○ mark signifies "Don't CARE" meaning that, input to pins marked ○ are ignored when EA=EB=0.
 ○ mark indicates counter is in normal operation.
 "1" Q } are FLIP-Flop actions carried out
 "2" Q } the counter.
 "3" Q }

• **Sequence of excitation**

< 3 Phase motor excitation system >

1 Phase excitation

Phase Step	$\phi 1$	$\phi 2$	$\phi 3$	$\phi 4$	$\bar{M}o$
0	1	0	0	0	0
1	0	1	0	0	1
2	0	0	1	0	1

↑ CCW
↓ CW

2 Phase excitation

Phase Step	$\phi 1$	$\phi 2$	$\phi 3$	$\phi 4$	$\bar{M}o$
0	1	1	0	0	0
1	0	1	1	0	1
2	1	0	1	0	1

↑ CCW
↓ CW

1-2 Phase excitation

Phase Step	$\phi 1$	$\phi 2$	$\phi 3$	$\phi 4$	$\bar{M}o$
0	1	0	0	0	0
1	1	1	0	0	1
2	0	1	0	0	1
3	0	1	1	0	1
4	0	0	1	0	1
5	1	0	1	0	1

↑ CCW
↓ CW

< 4 Phase motor excitation system >

1 Phase excitation

Phase Step	$\phi 1$	$\phi 2$	$\phi 3$	$\phi 4$	$\bar{M}o$
0	1	0	0	0	0
1	0	1	0	0	1
2	0	0	1	0	1
3	0	0	0	1	1

↑ CCW
↓ CW

2 Phase excitation

Phase Step	$\phi 1$	$\phi 2$	$\phi 3$	$\phi 4$	$\bar{M}o$
0	1	1	0	0	0
1	0	1	1	0	1
2	0	0	1	1	1
3	1	0	0	1	1

↑ CCW
↓ CW

1-2 Phase excitation

Phase Step	$\phi 1$	$\phi 2$	$\phi 3$	$\phi 4$	$\bar{M}o$
0	1	0	0	0	0
1	1	1	0	0	1
2	0	1	0	0	1
3	0	1	1	0	1
4	0	0	1	0	1
5	0	0	1	1	1
6	0	0	0	1	1
7	1	0	0	1	1

↑ CCW
↓ CW

• **Timing chart**

3 Phase motor excitation system
(1 phase excitation)

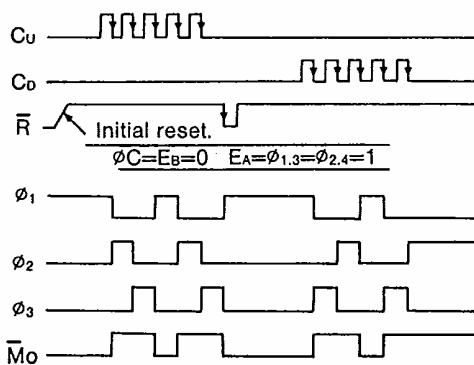

4 Phase motor excitation system
(2 phase excitation)

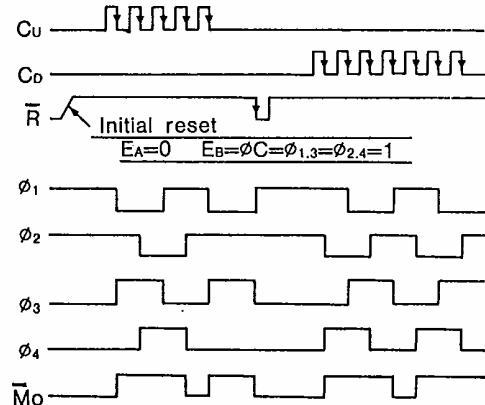

● **Absolute maximum rate** $T_a = 25^\circ\text{C}$

Item	Symbol	Rate Value	Conditions	Unit
Power supply voltage	VCC1	-0.5~+7.5		V
	VCC2	-0.5~+7		V
Surge output current	Io*1	±50	VCC1=VCC2=5V	mA
	Io*2	±20	VCC1=5V	mA
Output dielectric voltage *3	Vo*1	-1~+6	VCC2=5V	V
	Vo*2	-1~+6	VCC1=5V	V
Input voltage	Vi*4	-0.5~VCC+0.5	VCC1=5V	V
	Vi*5	-0.5~VCC+0.5	VCC1=5V	V
Power consumption	Pd	600	$T_a < 25^\circ\text{C}$	mW
Heat dissipation rate	K θ	6.5	$T_a > 25^\circ\text{C}$	mW/°C
Operation temperature	TOP	-10~+70		°C
Storage temperature	Tstg	-55~155		°C

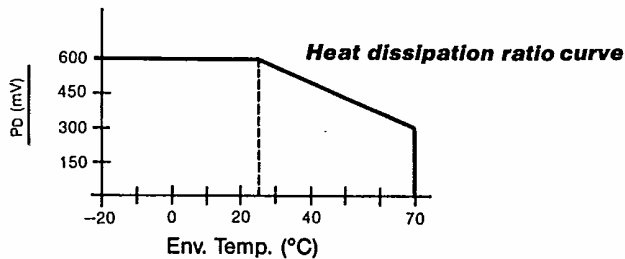

NOTE)

- *1: When output pin ($\phi_1, \phi_2, \phi_3, \phi_4$) is subjected to conditions indicate, output characteristics shall be: pulse range 10 μ /sec. repetition freq. 10KHz
- *2: When monitor pin (Mo) is subjected to conditions indicated, monitor short circuit shall occur within 1 sec.
- *3: If output pin is to be subjected to surge voltage from exterior source, surge current shall be 50mA max.
- *4: Cu, Co output pin
- *5: Input pin other than Cu, Co.

● **Limit of Recommended operation**

Item	Symbol	LIMIT		Conditions	Unit
		MIN	MAX		
Supply voltage	VCC1	4.5	5.5		V
	VCC2	4.5	5.5		V
Level "H" output current	IoH*1 ¹		-30	VCC1 = VCC2 = 5V	μ A
	IoH*2		-80*3	VCC1 = 5V	μ A
Level "L" output current	IoL*1		30	VCC1 = VCC2 = 5V	mA
	IoL*2		+3.2	VCC1 = 5V	mA
Operation frequency	f	100		tw = 2 μ Sec	KHz
Input pulse ange	tw	2			μ Sec

NOTE)

- *1): Output pin ($\phi_1, \phi_2, \phi_3, \phi_4$)
- *2): Monitor pin (Mo)
- *3): Output voltage to be specified to 2.4V.

● **Electrical characteristics**

$T_a = 25^\circ\text{C}$ VCC1 = VCC2 = 5V

Item	Symbol	Test Conditione	Rate			Unit
			MM	TYP	MAX	
Level "H" input voltage	ViH*1	VCC1 = 5V	2			V
Level "L" input voltage	ViL*1	VCC1 = 5V			0.5	V
Input threshold voltage	Vt+*2	VCC1 = 5V	1.3	2.0	2.4	V
	Vt-*2	VCC1 = 5V	0.5	0.8	1.2	V
Level "H" output voltage	VoH*3	IoH = -80 μ A	2.4			V
	VoH*4	IoH = -30mA VCC1 = VCC2 = 5V	2.5			V
Level "L" input voltage	VoL*3	IoL = 3.2 mA			0.4	V
	VoL*4	IoL = 30 mA VCC1 = VCC2 = 5 V			0.6	mA
Level "H" input current	IiH*1	VCC1 = 5V Vi = 5.5 V			0.15XN	mA
	IiH*2	VCC1 = 5 V Vi = 6.0 V			10	μ A
Level "L" input current	IiL*1	VCC1 = 5V Vi = 0.4 V			0.8XN	mA
	IiL*2	VCC1 = 5V Vi = 0.4 V			0.4	mA
Input threshold current	It+*2	VCC1 = 5V Vi = Vt+		0.13		mA
	It-*2	VCC1 = 5V Vi = Vt-		0.17		mA
Current consumption	Icc1*5	VCC1 = 5 V			20	mA
	Icc2*5	VCC1 = VCC2 = 5V			5	mA

NOTE)

- *1: Input other than Co, Cu shall be based upon:
 ϕ C: N=1 R=1
 EA: N=1 Eb: N=1
 ϕ 1.3 OFF ϕ 2, 4 OFF: N=2
- *2 Co, Cu input
- *3 Monitor output
- *4 ϕ 1, ϕ 2, ϕ 3, ϕ 4 Output
- *5 All input set to GND
 Ii output to open.

4

Stepping motor drive IC <<Application example>>

4 phase stepping motor

• 1 phase excitation

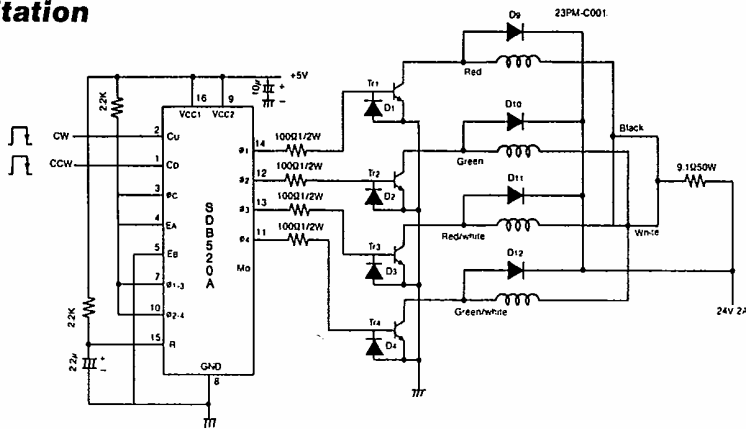

NOTE)
 Tr1~Tr4 2SC1884
 D1~D4 1S1587
 D5~D8 6BG11
 D9~D12 1BZ61
 C1~C3 1~10 μ F (MP)
 common to all wiring diagrams.

• 1·2 phase excitation

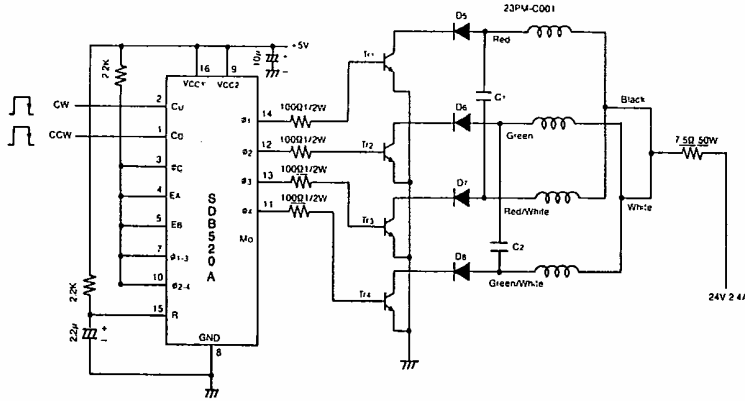

• 2 phase excitation

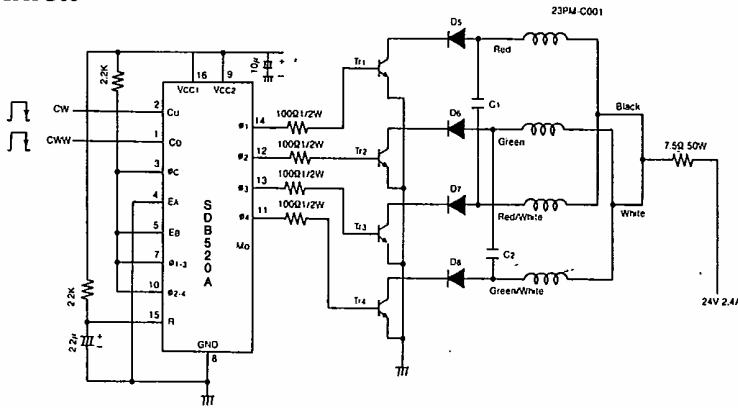

• Motor free operation diagram

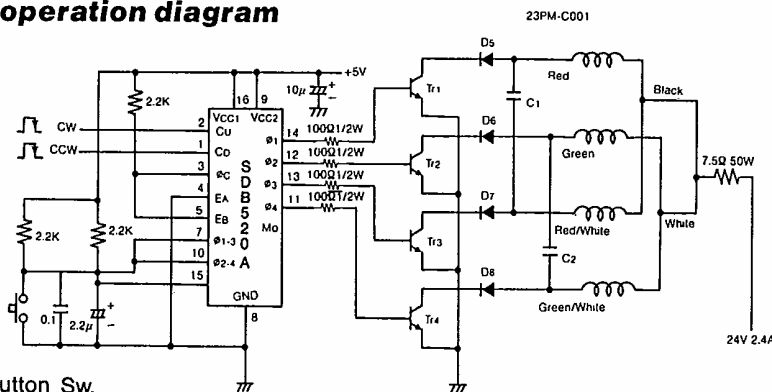

Button Sw.
 ON: Free operation mode
 OFF: Normal operation mode