

General Description

The SDC11168 is a single-phase bipolar drive motor driver that easily implements direct PWM drive systems with high excellent efficiency. The SDC11168 is optimal for fan motor driver in personal computer power supply systems and CPU cooling fan systems.

Applications

- CPU cooler fan

Features

- Single-phase bipolar drive(16V/1A)
- Variable speed control with thermistor input or PWM drive with additional components.
- Include hall bias circuit
- Minimum speed settable
- Over-current protection
- Lock protect and auto restart function
- FG output and RD output signal available
- Include thermal shut down circuit

Pin Configuration

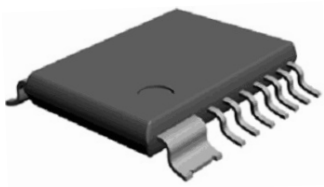

HTSSOP-14

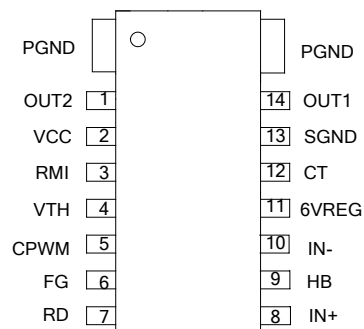

SSOP-16

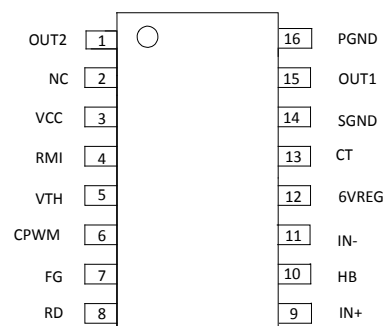

Figure 1. Pin Configuration

Pin Number		Pin Name	Function
HTSSOP-14	SSOP-16		
1	1	OUT2	Driver output2
	2	NC	No connection
2	3	VCC	Supply voltage
3	4	RMI	Minimum speed setting
4	5	VTH	Speed setting
5	6	CPWM	Oscillation frequency setting
6	7	FG	Rotation speed output
7	8	RD	Rotation detection output
8	9	IN+	Hall input+
9	10	HB	Hall bias
10	11	IN-	Hall input-
11	12	6VREG	6V regulator
12	13	CT	Shutdown time and restart time setting
13	14	SGND	Control stage GND
14	15	OUT1	Driver output1
	16	PGND	Power ground

Table 1. Pin Description

Functional Block Diagram

Figure 2. Functional Block Diagram

Ordering Information

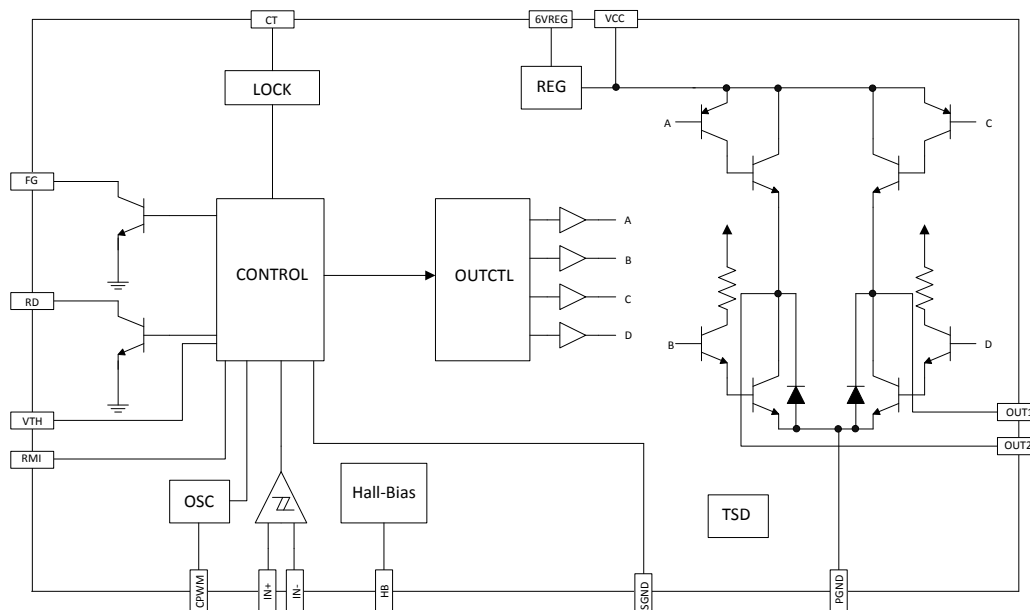
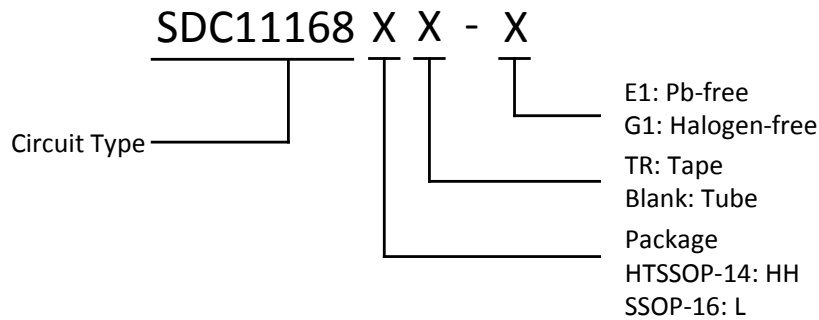

Package	Temperature Range	Part Number		Marking ID		Packing Type
		Pb-free	Halogen-free	Pb-free	Halogen-free	
HTSSOP-14	-40°C~85°C	SDC11168HHTR-E1	SDC11168HHTR-G1	11168	11168-G	Tape
		SDC11168HH-E1	SDC11168HH-G1	11168	11168-G	Tube
SSOP-16		SDC11168LTR-E1	SDC11168LTR-G1	SDC11168	SDC11168-G	Tape
		SDC11168L-E1	SDC11168L-G1	SDC11168	SDC11168-G	Tube

Absolute Maximum Ratings (Note: Stresses greater than those listed under Absolute Maximum Ratings may cause permanent damage to the device.)

Parameter	Symbol	Conditions	Min	Max	Unit
Supply voltage	V_{CCMAX}	-	-	18	V
Output current	I_{OUTMAX}	-	-	1.0	A
Output supply voltage	V_{OUTMAX}	-	-	18	V
HB output current	I_{HBMAX}	-	-	10	mA
VTH input voltage	V_{THMAX}	-	-	7.0	V
RD/FG output supply voltage	$V_{RD/FGMAX}$	-	-	18	V
RD/FG output current	$I_{RD/FGMAX}$	-	-	10	mA
Allowable maximum power dissipation	Pd_{MAX1}	HTSSOP-14	-	1.1	W
	Pd_{MAX2}	SSOP-16	-	0.8	W
Operating temperature	T_{OPR}	-	-40	90	°C
Storage temperature	T_{STG}	-	-55	150	°C

Table 2. Absolute Maximum Ratings

Recommended Operating Conditions

Parameter	Symbol	Conditions	Min	Max	Unit
Supply voltage	V_{CC}	-	4.5	16	V
Threshold input voltage range	V_{TH}	-	0	6.0	V
Common-mode input voltage range	V_{ICM}	-	0.2	3.0	V

Table 3. Commended Operating Conditions

Electrical Characteristics ($T_a=25^{\circ}C$, $V_{CC}=12V$, unless otherwise specified)

Parameter	Symbol	Conditions	Min	Typ	Max	Unit
Operating current	I_{CC1}	Rotation mode	12	16	20	mA
	I_{CC2}	Lock protect mode	-	6.5	10	mA
6V Regulator	6VREG	$I_O=-5mA$	5.8	6	6.2	V
HB voltage	V_{HB}	$I_{HB}=5mA$	1.1	1.25	1.4	V
CPWM high level voltage	V_{CRH}	-	3.45	3.6	3.75	V
CPWM low level voltage	V_{CRL}	-	1.95	2.05	2.15	V
CPWM oscillation frequency	f_{PWM}	$C=100pF$	18	25	32	kHz
CT pin high level voltage	V_{CTH}	-	3.45	3.6	3.75	V
CT pin low level voltage	V_{CTL}	-	1.55	1.7	1.85	V
CT charge current	I_{CT1}	$V_{CT}=0V$	1.5	2.0	2.5	uA
CT discharge current	I_{CT2}	$V_{CT}=4.2V$	0.15	0.2	0.25	uA
CT charge/discharge current ratio	R_{CT}	$R_{CD}=I_{CT1}/I_{CT2}$	9.5	11	12.5	-
Output lower side saturation	V_{OL}	$I_O=200mA$	-	0.2	0.3	V
Output upper side saturation	V_{OH}	$I_O=200mA$	-	0.9	1.1	V
Hall input sensitivity	V_{HN}	-	-	± 10	± 20	mV
RD/FG pin low voltage	V_{FG}	$I_{FG}=5mA$	-	0.2	0.3	V
RD/FG pin leak current	I_{FGL}	$V_{FG}=7V$	-	-	30	uA

Table 4. Electrical Characteristics

Truth Table

VTH	IN-	IN+	CPWM	CT	OUT1	OUT 2	FG	RD	Mode	
L (OPEN)	H	L	H	L	H	L	L	ON	Rotation(Drive) PWM OFF	
	L	H			L	H	OFF			
H	H	L	L		OFF	L	L		OFF	Rotation(regeneration) PWM ON
	L	H			L	OFF	OFF			
-	H	L	-	H	H	OFF	L	OFF	Lock Protection	
-	L	H			OFF	H	OFF			

 CPWM-H: $V_{CPWM} > V_{TH}$, CPWM-L: $V_{CPWM} < V_{TH}$

Table 5. Truth Table

Power Dissipation Curve

Figure 3. Power Dissipation Curve (HTSSOP-14)

Typical Application

Figure 4. Typical Application

Function Description

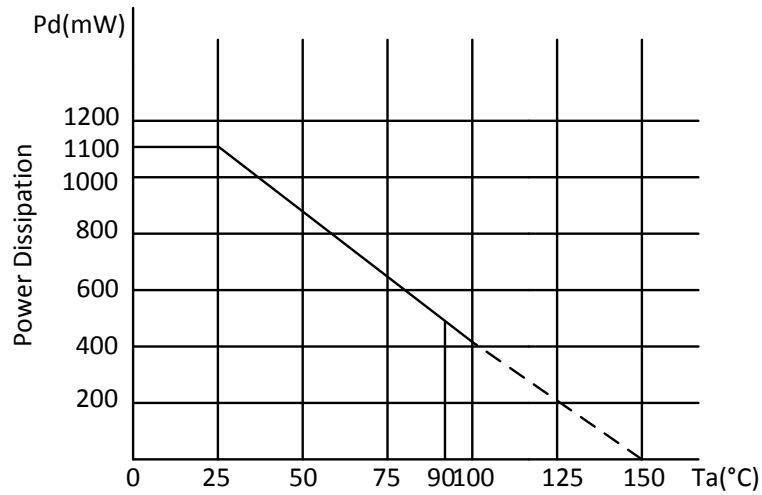
Power Supply and Ground Lines

P-GND is connected to the motor power supply system and S-GND is connected to the control circuit power supply system.

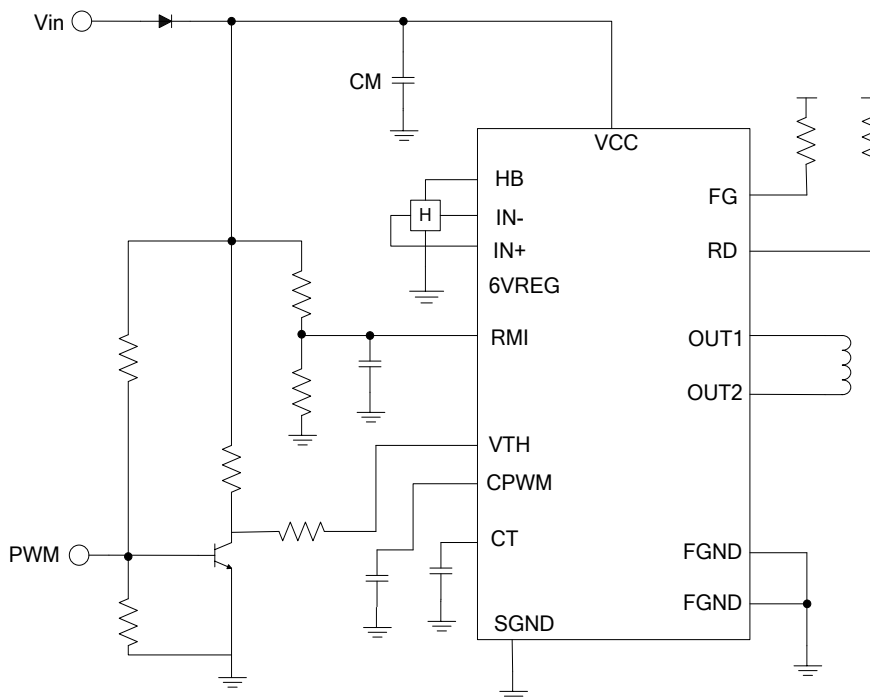
These two systems should be formed from separate lines and the control system external components should be connected to S-GND.

Regeneration Power Supply Stabilization Capacitor

The capacitor CM provides power supply stabilization for both PWM drive and kickback absorption. A capacitor with a value of over 0.1 μ F is used for CM. A large capacitor must be used when the coil inductance is large or when the coil resistance is low. Since this IC adopts a technique in which switching is performed by the high side transistor and regeneration is handled by the low side transistor, the pattern connecting CM to VCC and P-GND must be as wide and as short as possible.

Hall Input

Lines that are as short as possible must be used to prevent noise from entering the system. The Hall sensor input circuit consists of a comparator with hysteresis (20mV). We recommend that the Hall sensor input level be at least three times this hysteresis, i.e. at least 60mV_{p-p}.

PWM Oscillation Frequency Setting Capacitor

If a value of 100pF is used for CP, the oscillator frequency will be $f = 25\text{kHz}$, and this will be the basic frequency of the PWM signal.

RD Output

This is an open collector output. It outputs a low level when the motor is turning and a high level when it is stopped. This pin must be left open if unused.

FG Output

This is an open collector output, and a rotation count detection function can be implemented using this FG output, which corresponds to the phase switching. This pin must be left open if unused.

HB Pin

This pin provides a Hall effect sensor bias constant-voltage output of 1.25V.

RMI Pin

Connect this pin to VTH if unused. Even if unused, the IC is set internally to operate at a 10% drive duty at the voltage corresponding to the lowest speed. (The capacitor is used to set up full-speed mode at startup.)

Control Timing Chart

Figure 5. Control Timing Chart

Minimum Speed Setting Mode

A VTH voltage level is generated when the thermistor detects the set temperature. At low temperatures, the fan motor turns at the lowest speed, which is set with the RMI pin. The SDC11168 compares the CPWM oscillator voltage with the RMI pin voltage and sets the duty for the lowest drive state.

Low Speed to High-Speed Mode

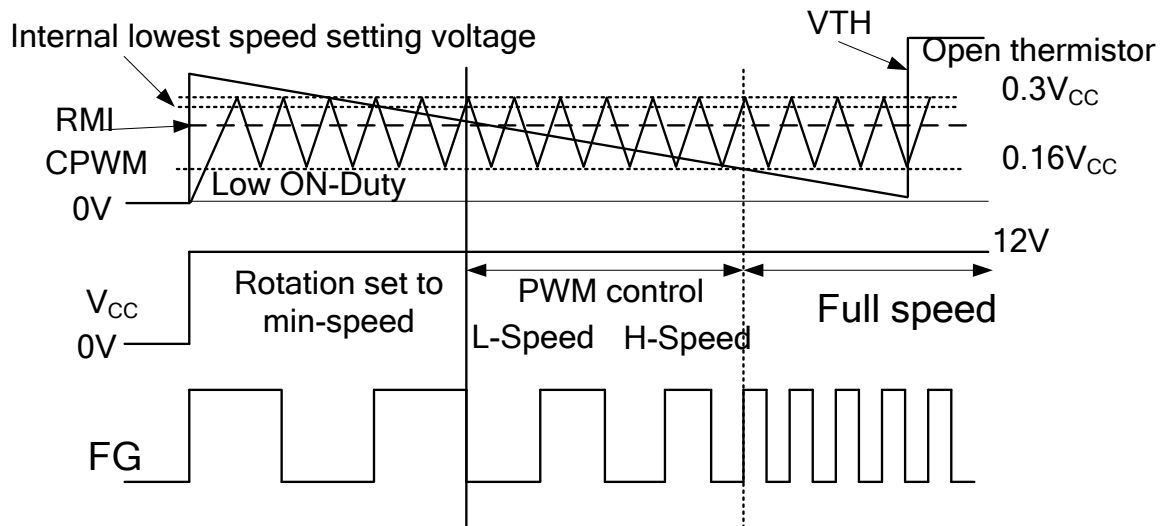
The PWM signal is controlled by comparing the CPWM oscillation voltage that cycles between 1.2V and 3.8V and the VTH voltage.

When the VTH voltage is lower, the high and low side transistors are turned on, and when the VTH voltage is higher, the high side transistor is turned off and the coil

current is regenerated through the low side transistor. Thus the output on duty increases as the VTH voltage becomes lower, the coil current increases, and the motor speed increases. Rotation speed feedback is provided by the FG output.

Full Drive Mode

The SDC11168 switches to full-speed mode above a certain temperature.

Thermistor Removed Mode

If the thermistor is removed, the VTH input voltage will rise. However, the output will go to full drive at 100% and the motor will run at full speed.

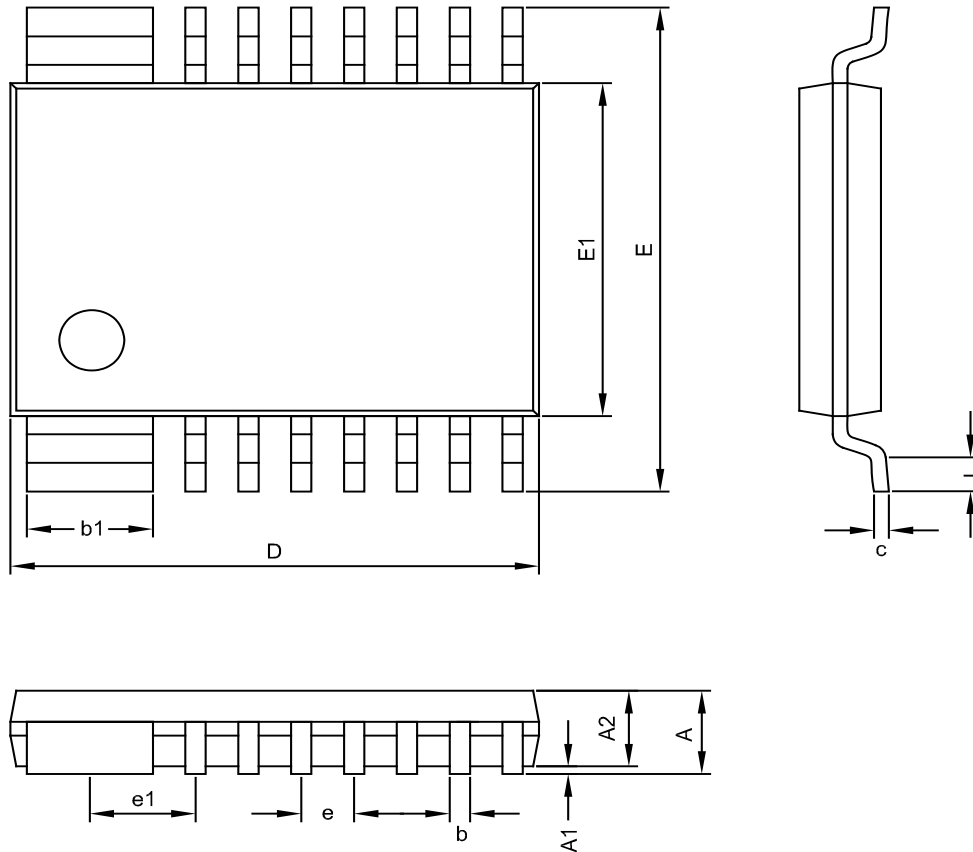
Package Dimension
HTSSOP-14

Symbol	Dimensions In Millimeters		Dimensions In Inches	
	Min	Max	Min	Max
A	--	1.200	--	0.048
A1	0.000	0.150	0.000	0.006
A2	0.850	1.050	0.033	0.041
D	6.350	6.550	0.247	0.258
E	6.200	6.600	0.244	0.260
E1	4.300	4.500	0.169	0.177
c	0.090	0.200	0.004	0.008
b	0.190	0.300	0.008	0.012
b1	1.470	1.570	0.058	0.063
e	0.650(BSC)		0.026(BSC)	
e1	1.300(BSC)		0.051(BSC)	
L	0.450	0.750	0.018	0.030

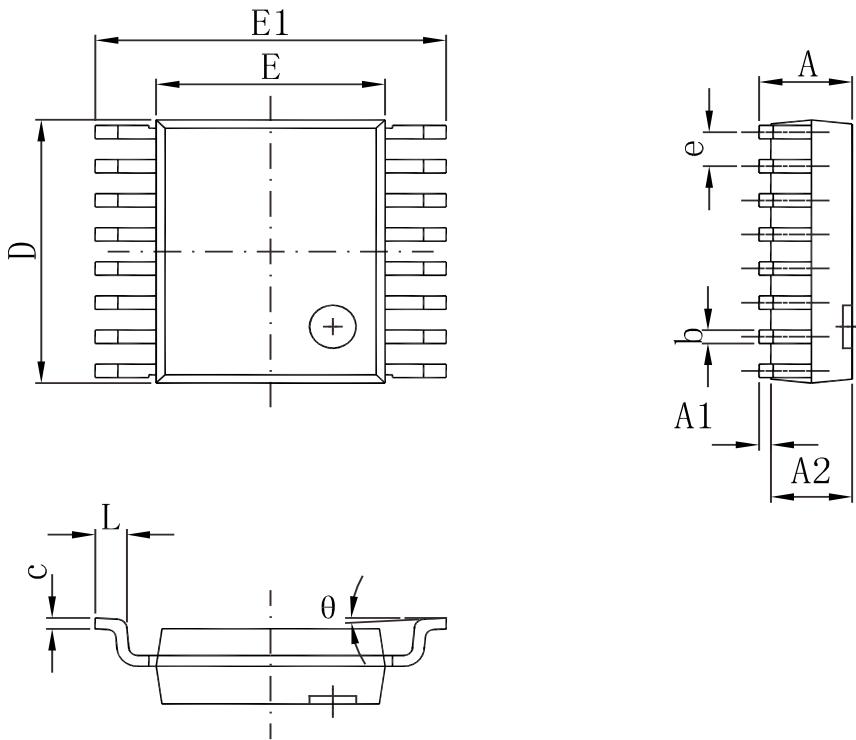
SSOP-16

Symbol	Dimensions In Millimeters		Dimensions In Inches	
	Min	Max	Min	Max
A	1.350	1.750	0.053	0.069
A1	0.100	0.250	0.004	0.010
A2	1.350	1.550	0.053	0.061
b	0.200	0.300	0.008	0.012
c	0.170	0.250	0.007	0.010
D	4.700	5.100	0.185	0.200
e	0.635(BSC)		0.025(BSC)	
E1	5.800	6.200	0.228	0.244
E	3.800	4.000	0.150	0.157
L	0.400	1.270	0.016	0.050
θ	0°TYP.	8°TYP.	0°TYP.	8°TYP.

**Shaoxing Devechip Microelectronics Co., Ltd.**

<http://www.sdc-semi.com/>

IMPORTANT NOTICE

Information in this document is provided solely in connection with Shaoxing Devechip Microelectronics Co., Ltd. (abbr. SDC) products. SDC reserves the right to make changes, corrections, modifications or improvements, to this document, and the products and services described herein at anytime, without notice. SDC does not assume any responsibility for use of any its products for any particular purpose, nor does SDC assume any liability arising out of the application or use of any its products or circuits. SDC does not convey any license under its patent rights or other rights nor the rights of others.

© 2013 Devechip Microelectronics - All rights reserved

Contact us:**Headquarters of Shaoxing**

Address: Tian Mu Road, No13,

Shaoxing city, Zhejiang province, China

Zip code: 312000

Tel: (86) 0575-8861 6750

Fax: (86) 0575-8862 2882

Shenzhen Branch

Address: 22A, Shangbu building, Nan Yuan Road, No.68,

Futian District, Shenzhen city, Guangdong province, China

Zip code: 518031

Tel: (86) 0755-8366 1155

Fax: (86) 0755-8301 8528