

General Description

SDC280 is a CMOS integrated circuit which includes Hall sensor and output drive circuits. It's widely used in various small two-phase fans and DC motors. The locked protection and auto-restart function is integrated inside the IC. Input offset voltage can be dynamically adjusted by built-in chopper amplifier, greatly improving the magnetic field sensitivity. It is built-in power reverse protection function.

Features

- High voltage CMOS technology
- Peak output current up to 1A
- Operating voltage range:3.5V~24V
- Sustainable 350mA operating current
- High sensitivity Hall sensor
- Locked protection and auto-restart
- Power reverse protection
- Including protection diodes to clamp the output
- Operating temperature: -40°C~85°C
- Package: TO-94

Applications

- Brushless DC fan motors
- Brushless DC motors



Figure 1. Package Type

Pin Configuration

Figure 2. Pin Configuration

Pin Number	Pin Name	Functions
1	VDD	Power supply pin
2	DO	Output 1 pin
3	DOB	Output 2 pin
4	GND	Ground pin

Table 1. Pin Description

Functional Block Diagram

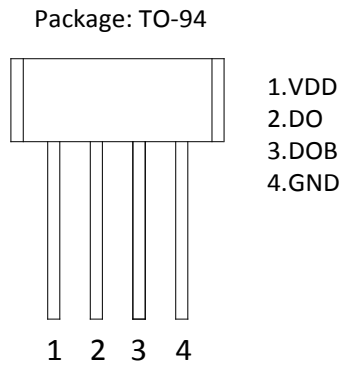
Figure 3. Functional Block Diagram

Ordering Information

Package	Temperature Range	Part Number		Marking ID		Packing Type
		Pb-free	Halogen-free	Pb-free	Halogen-free	
TO-94	-40°C~85°C	SDC280Z4-E1	SDC280Z4-G1	280	280G	Bulk

SDC CONFIDENTIAL DOCUMENT

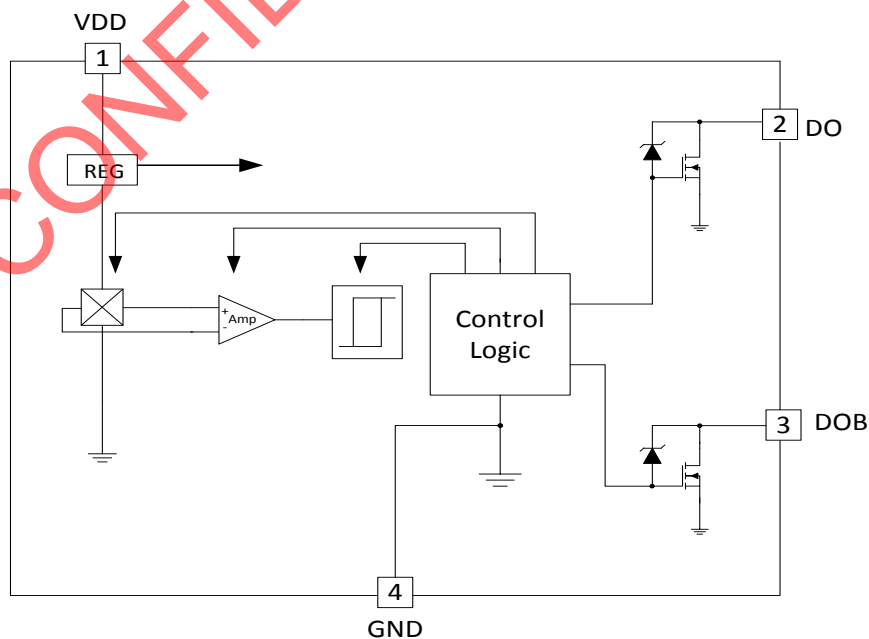
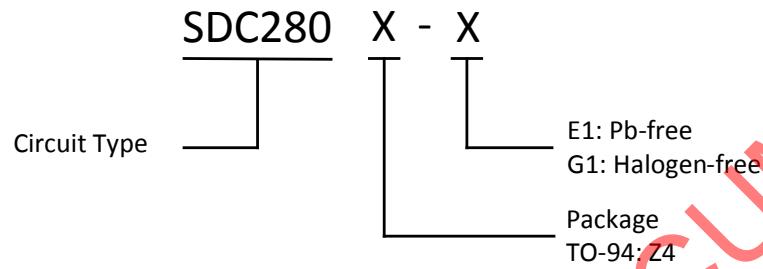
Absolute Maximum Ratings (Note: Stresses greater than those listed under absolute maximum ratings may cause permanent damage to the device.)

Parameters		Symbol	Value	Unit
Power supply		V_{DD}	26	V
Magnetic field intensity		B	-	mT
Output current	Continuous	I_{OUT}	350	mA
	Hold		500	
	Peak		1000	
Storage temperature		T_S	-65 to 150	°C
Power dissipation		P_D	550	mW
Maximum junction temperature		T_J	150	°C
ESD,HBM model per MIL-STD-883H Method 3015		HBM	2000	V
ESD,MM model per JEDEC EIA/JESD22-A115		MM	200	V
Latch-up per JEDEC78		-	200	mA

Table 2. Absolute Maximum Ratings

Recommended Operating Conditions

Parameter	Symbol	Min	Max	Unit
Power supply	V_{DD}	3.5	24	V
Operation temperature	T_a	-40	85	°C
Operating current (continuous), $V_{DD}=24V$	I_{OUT}	-	300	mA

Table 3. Recommended Operating Conditions

Electrical Characteristics ($T_a=25^\circ\text{C}$, $V_{DD}=12\text{V}$, unless otherwise specified)

Parameter	Symbol	Conditions	Min	Typ	Max	Unit
Power supply	V_{DD}	-	3.5	12	24	V
Operating current	I_{DD}	$V_{DD}=24\text{V}$, output open	-	4.2	6.0	mA
Output clamp voltage	$V_{OUT-CLAMP}$	-	50	57	-	V
Output saturation voltage	V_{SAT}	$V_{DD}=12\text{V}$, $I_O=300\text{mA}$	-	0.35	0.5	V
Output leakage current	I_{LEAK}	$V_{DD}=V_{DO/DOB}=12\text{V}$	-	0.1	10	μA
Lock on time1	t_{ON1}	$V_{DD}>7\text{V}$	-	300	-	ms
Lock off time1	t_{OFF1}	$V_{DD}>7\text{V}$	-	1.8	-	S
Lock on time2	t_{ON2}	$V_{DD}<5\text{V}$	-	600	-	ms
Lock off time2	t_{OFF2}	$V_{DD}<5\text{V}$	-	3.6	-	S

Table 4. Electrical Characteristics

Magnetic Characteristics ($T_a=25^\circ\text{C}$, $V_{DD}=12\text{V}$, unless otherwise specified)

Parameter	Symbol	Min	Typ	Max	Unit
Operating point	B_{OP}	10	25	40	GS
Release point	B_{RP}	-40	25	-10	GS
Hysteresis	B_{Hys}	40	50	60	GS

Table 5. Magnetic Characteristics

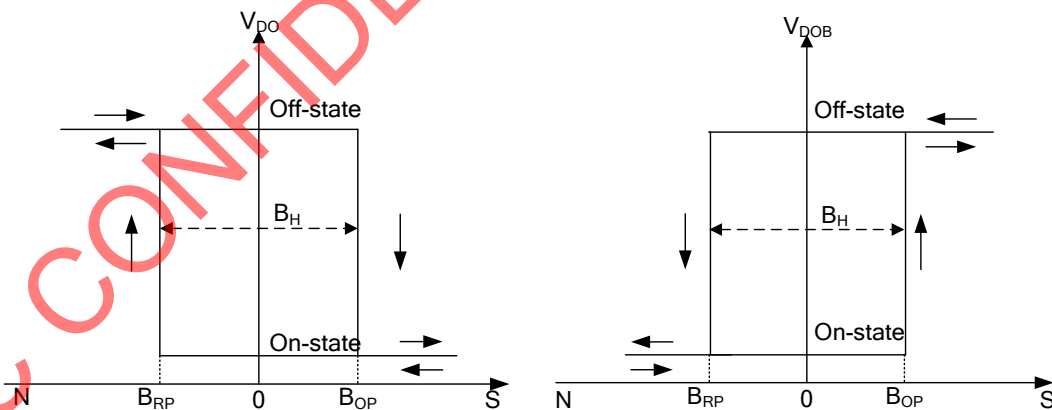

Figure 4. Magnetic Characteristics

Power Dissipation Curve

Figure 5. Power Dissipation Curve

Function Description

SDC280 is a single-chip integrated circuit that drives two-phase brushless DC fan. It contains voltage regulator, Hall voltage generator, chopper amplifier, hysteresis comparator, oscillator, logic control unit, and output high-voltage switch. After fan is powered on, the internal oscillator begins to work, the output switching signal begins to drive switches work in a certain delay, the fan is started. The magnetic field signal is sensed by the internal Hall-voltage generator to produce the Hall voltage,

through the chopper amplifier and hysteresis comparator, to generate the alternating drive signal to drive switching transistors alternately turn on the fan to finish booting. When the fan is locked, the internal Hall sensor senses the same signal and hysteresis comparator outputs fixed signal. Through the logic controller and a certain delay, a signal is generated to make the output switch off, fans are protected. When locked condition is released, like the start, the fan will be automatically restarted.

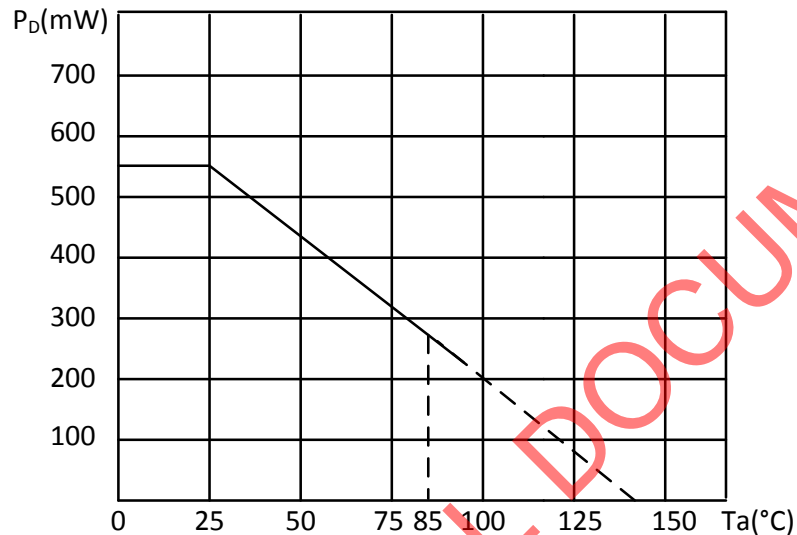
Typical Application

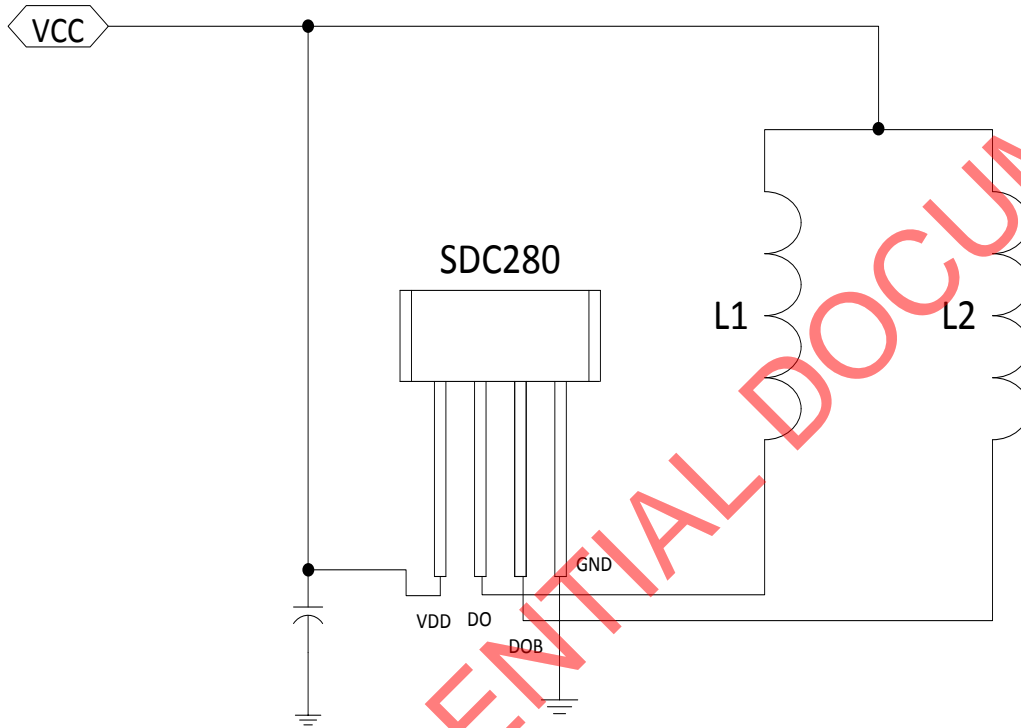
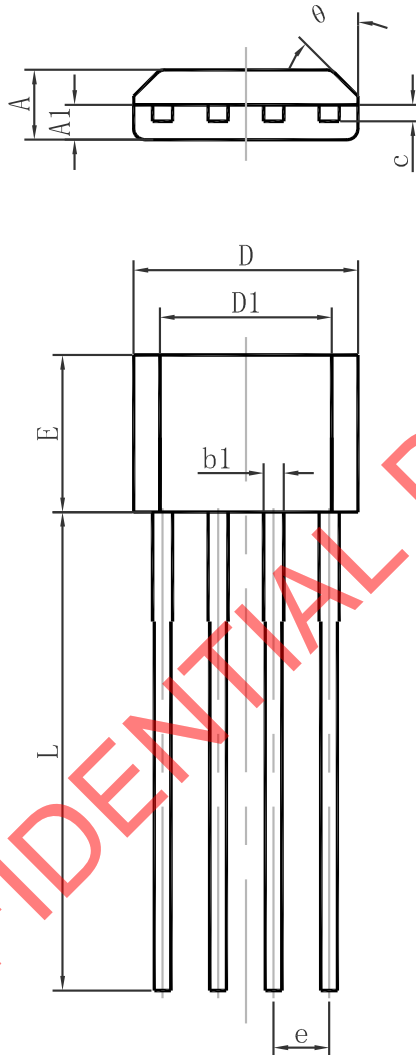

Figure 6. Typical Application

Package Dimension
TO-94

Symbol	Dimensions In Millimeters		Dimensions In Inches	
	Min	Max	Min	Max
A	1.400	1.800	0.055	0.071
A1	0.700	0.900	0.028	0.035
b1	0.380	0.550	0.015	0.022
C	0.360	0.510	0.014	0.020
D	5.050	5.350	0.202	0.214
D1	4.550	4.850	0.128	0.194
E	3.450	3.750	0.136	0.148
e	1.270 TYP.		0.050 TYP.	
L	14.300	14.700	0.572	0.588
θ	10°TYP.		10°TYP.	



Shaoxing Devechip Microelectronics Co., Ltd.

<http://www.sdc-semi.com/>

IMPORTANT NOTICE

Information in this document is provided solely in connection with Shaoxing Devechip Microelectronics Co., Ltd. (abbr. SDC) products. SDC reserves the right to make changes, corrections, modifications or improvements, to this document, and the products and services described herein at anytime, without notice. SDC does not assume any responsibility for use of any its products for any particular purpose, nor does SDC assume any liability arising out of the application or use of any its products or circuits. SDC does not convey any license under its patent rights or other rights nor the rights of others.

© 2013 Devechip Microelectronics - All rights reserved

Contact us:

Headquarters of Shaoxing

Address: Tian Mu Road, No13,
Shaoxing city, Zhejiang province, China
Zip code: 312000
Tel: (86) 0575-8861 6750
Fax: (86) 0575-8862 2882

Shenzhen Branch

Address: 22A, Shangbu building, Nan Yuan Road, No.68,
Futian District, Shenzhen city, Guangdong province, China
Zip code: 518031
Tel: (86) 0755-8366 1155
Fax: (86) 0755-8301 8528