

### General Description

The SDC431 is three-terminal adjustable regulator with guaranteed thermal stability over applicable temperature ranges. The output voltage can be set to any value between  $V_{REF}$  2.5V and 36V with two external resistors. It features sharp turn-on characteristic, which makes it ideal substitute for zener diode in many applications.

### Features

- Programmable Precise output voltage from 2.5V to 36V
- Low dynamic output impedance 0.15Ω typical
- Sink current capability from 1mA to 100mA
- Low output noise voltage
- Fast turn-on response
- Package: SOT-23, TO-92

### Applications

- Charger
- Adapter
- Switch power supply

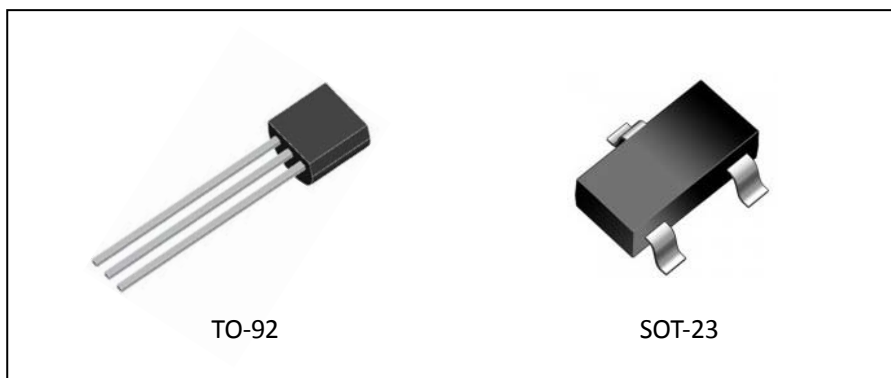

Figure 1. Package Type

Pin Configuration

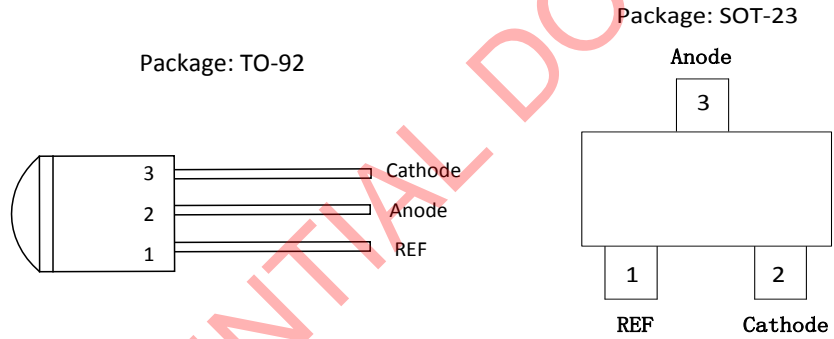

Figure 2. Pin Configuration

Functional Block Diagram

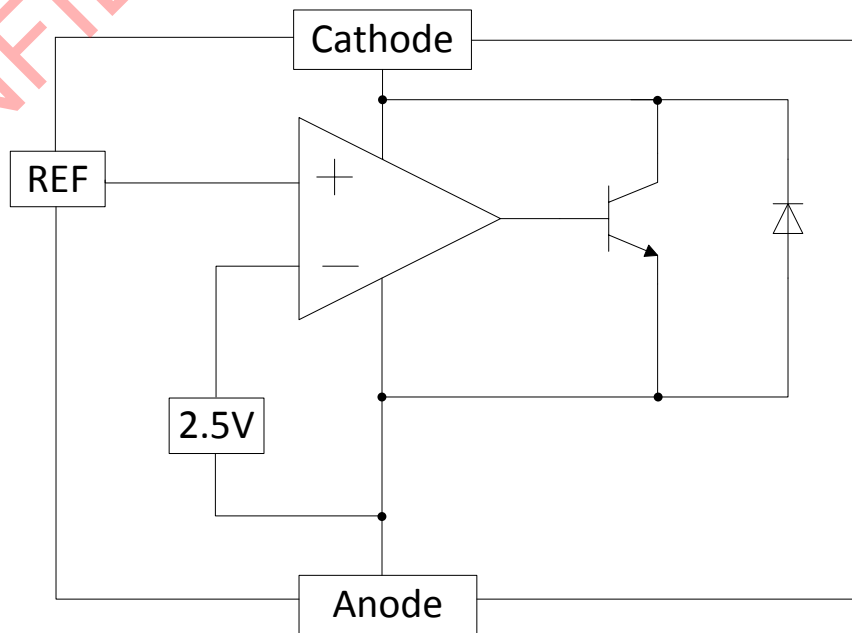
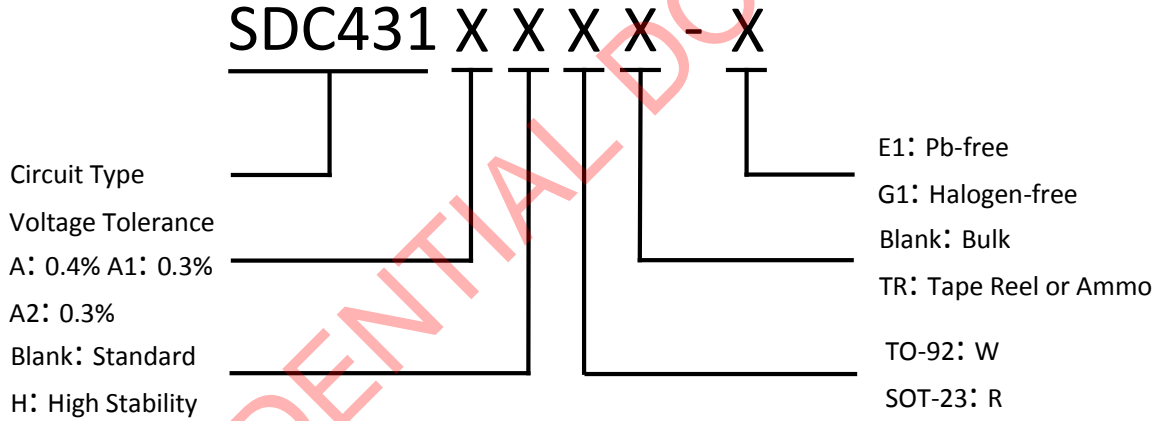

Figure 3. Functional Block Diagram

**Ordering Information**

Package	Temperature Range	Voltage Tolerance	Part Number		Marking ID		Packing Type
			Pb-free	Halogen-free	Pb-free	Halogen-free	
SOT-23	-40~125°C	A: 0.4%	SDC431AHRTR-E1	SDC431AHRTR-G1	YWW	YWWG	Tape Reel
		A1: 0.3%	SDC431A1HRTR-E1	SDC431A1HRTR-G1	YWW	YWWG	Tape Reel
		A2: 0.3%	SDC431A2HRTR-E1	SDC431A2HRTR-G1	YWW	YWWG	Tape Reel
A: 0.4%		SDC431AW-E1	SDC431AW-G1	SDC431	SDC431G	Bulk	
A1: 0.3%		SDC431A1W-E1	SDC431A1W-G1	SDC431	SDC431G	Bulk	
A2: 0.3%		SDC431A2W-E1	SDC431A2W-G1	SDC431	SDC431G	Bulk	
A: 0.4%		SDC431AHW-E1	SDC431AHW-G1	SDC431	SDC431G	Bulk	
A1: 0.3%		SDC431A1HW-E1	SDC431A1HW-G1	SDC431	SDC431G	Bulk	
A2: 0.3%		SDC431A2HW-E1	SDC431A2HW-G1	SDC431	SDC431G	Bulk	
TO-92		A: 0.4%	SDC431AWTR-E1	SDC431AWTR-G1	SDC431	SDC431G	Ammo
		A1: 0.3%	SDC431A1WTR-E1	SDC431A1WTR-G1	SDC431	SDC431G	Ammo
		A2: 0.3%	SDC431A2WTR-E1	SDC431A2WTR-G1	SDC431	SDC431G	Ammo
		A: 0.4%	SDC431AHWTR-E1	SDC431AHWTR-G1	SDC431	SDC431G	Ammo
		A1: 0.3%	SDC431A1HWTR-E1	SDC431A1HWTR-G1	SDC431	SDC431G	Ammo
		A2: 0.3%	SDC431A2HWTR-E1	SDC431A2HWTR-G1	SDC431	SDC431G	Ammo

**Absolute Maximum Ratings** (NOTE: Stresses greater than those listed under Absolute Maximum Ratings may cause permanent damage to the device.)

Parameter	Symbol	Max	Unit
Cathode voltage	$V_{KA}$	40	V
Cathode current range	$I_{KA}$	-100~150	mA
Reference input current range	$I_{REF}$	10	mA
Power dissipation1 (SOT-23)	$P_{D1}$	370	mW
Power dissipation2 (TO-92)	$P_{D2}$	770	mW
Operation temperature range	$T_{OPR}$	-40~125	°C
Storage temperature range	$T_{STG}$	-60~150	°C

Table1. Absolute Maximum Ratings

**Recommended Operating Conditions**

Parameter	Symbol	Min	Max	Unit
Cathode voltage	$V_{KA}$	2.5	36	V
Cathode current range	$I_{KA}$	1	10	mA
Operation temperature	$T_{OPR}$	-40	85	°C

Table 2. Recommended Operating Conditions

**Electrical Characteristics** (Ta=25°C, unless otherwise specified.)

Parameter	Symbol	Conditions	Min	Typ	Max	Unit	
Reference voltage	$V_{REF}$	$V_{KA}=V_{REF}$ , $I_{KA}=10mA$	A	2.490	2.500	2.510	V
			A1	2.475	—	2.490	
			A2	2.510	—	2.525	
Deviation of reference input voltage over temperature	$\Delta V_{REF}/\Delta T$	$V_{KA}=V_{REF}$ , $I_{KA}=10mA$ , $T_{MIN} \leq T_a \leq T_{MAX}$	—	4.5	16	mV	
Ratio of change in reference input voltage to the change in cathode voltage	$\Delta V_{REF}/\Delta V$	$I_{KA}=10mA$	$\Delta V_{KA}=10V \sim V_{REF}$	—	-1.0	-2.7	mV/V
			$\Delta V_{KA}=36V \sim 10V$	—	-0.5	-2.0	
Reference current	$I_{REF}$	$I_{KA}=10mA$ , $R1=10k\Omega$ , $R2=\infty$	—	0.8	4	uA	
Deviation of reference current over full temperature range	$\Delta I_{REF}/\Delta T$	$I_{KA}=10mA$ , $R1=10k\Omega$ , $R2=\infty$ , $T_{MIN} \leq T_a \leq T_{MAX}$	—	0.4	1.2	uA	
Minimum cathode current for regulation	$I_{KA(MIN)}$	$V_{KA}=V_{REF}$	—	0.4	1.0	mA	
Off-state cathode current	$I_{KA(off)}$	$V_{KA}=36V$ , $V_{REF}=0V$	—	0.02	1.0	uA	
Dynamic impedance	$Z_{KA}$	$V_{KA}=V_{REF}$ , $I_{KA}=1mA \sim 100mA$ $\leq 1.0kHz$	—	0.15	0.5	$\Omega$	

Table 3. Electrical Characteristics

Typical Performance Characteristics

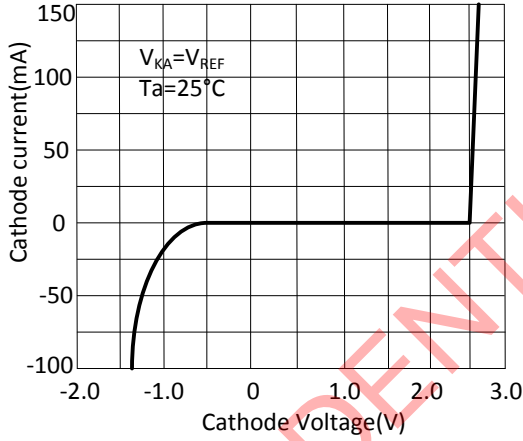

Figure 4. Cathode Current vs. Cathode Voltage

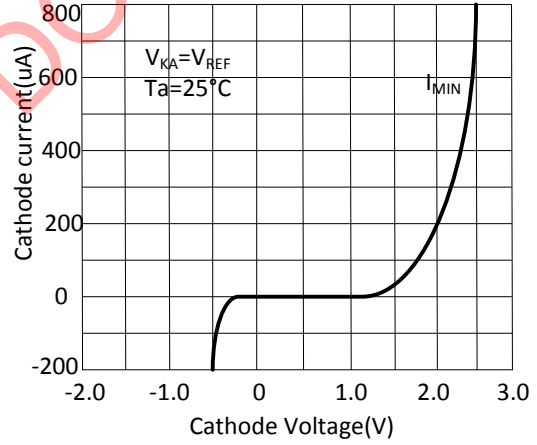

Figure 5. Cathode Current vs. Cathode Voltage

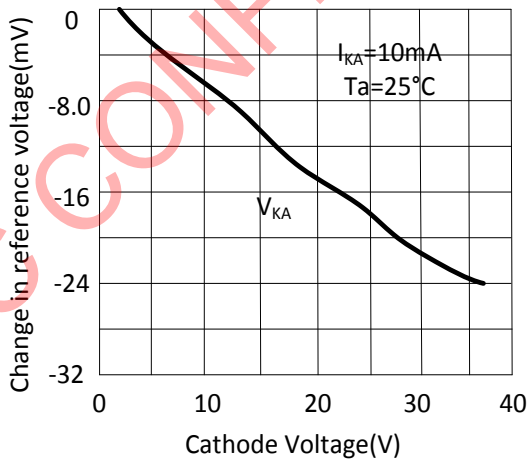

Figure 6. Change of Reference vs. Cathode Voltage

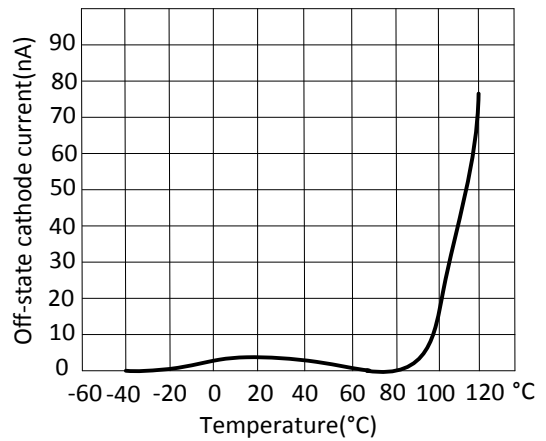

Figure 7. Off-state cathode current

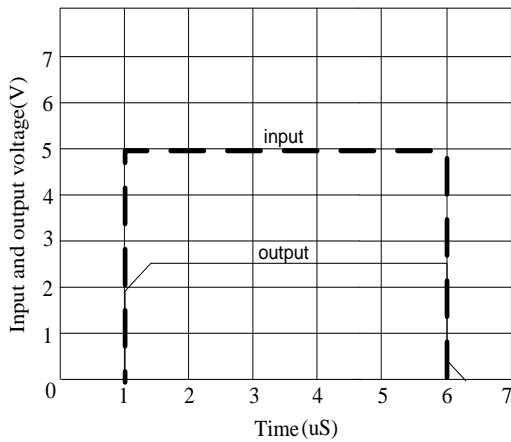
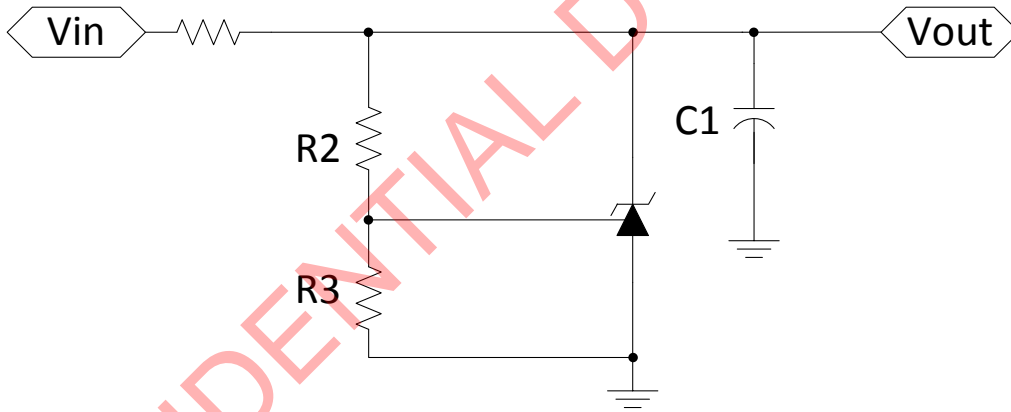
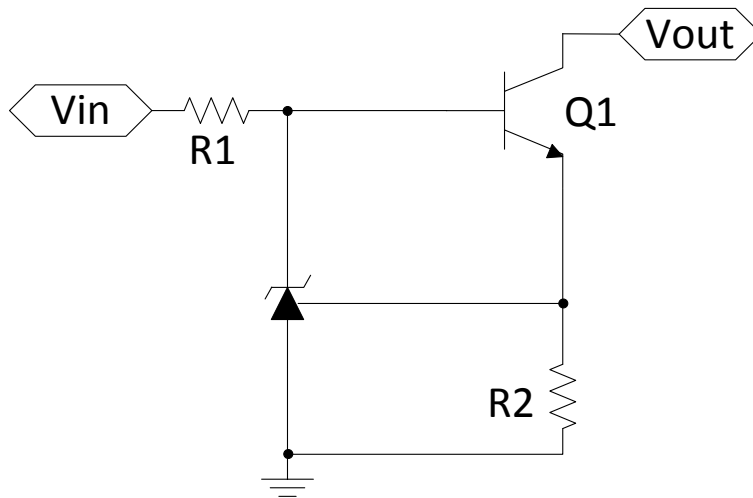
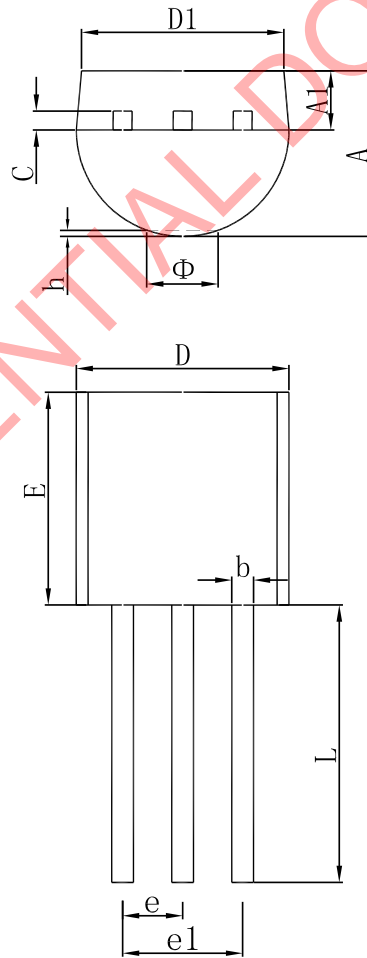

Figure 8. Pulse Response

**Typical Application**

 Figure 9.  $V_{out} = (1 + R2/R3) * V_{REF}$ 

 Figure 10.  $I_O = V_{REF}/R2$

**Package Dimension**
**TO-92**

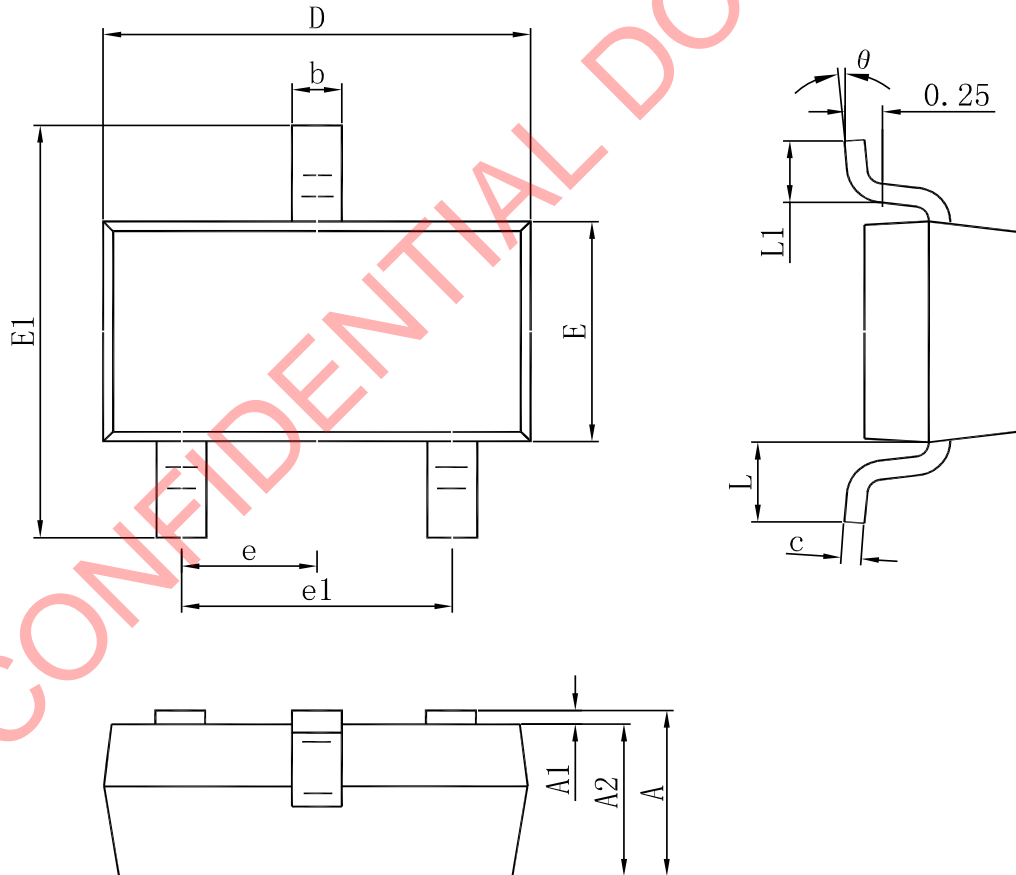
Symbol	Dimensions In Millimeters		Dimensions In Inches	
	Min	Max	Min	Max
A	3.300	3.700	0.130	0.146
A1	1.100	1.400	0.043	0.055
b	0.380	0.550	0.015	0.022
c	0.360	0.510	0.014	0.020
D	4.300	4.700	0.169	0.185
D1	3.430	-	0.135	-
E	4.300	4.700	0.169	0.185
e	1.270 TYP.		0.050 TYP.	
e1	2.440	2.640	0.096	0.104
L	14.100	14.500	0.555	0.571
$\Phi$	-	1.600	-	0.063
h	0.000	0.380	0.000	0.015



**SOT-23**

Symbol	Dimensions In Millimeters		Dimensions In Inches	
	Min	Max	Min	Max
A	0.900	1.150	0.035	0.045
A1	0.000	0.100	0.000	0.004
A2	0.900	1.050	0.035	0.041
b	0.300	0.500	0.012	0.020
c	0.080	0.150	0.003	0.006
D	2.800	3.000	0.110	0.118
E	1.200	1.400	0.047	0.055
E1	2.250	2.550	0.089	0.100
e	0.095 TYP.		0.037 TYP.	
e1	1.800	2.000	0.071	0.079
L	0.550 REF.		0.022 REF.	
L1	0.300	0.500	0.012	0.020
$\theta$	0°	8°	0°	8°

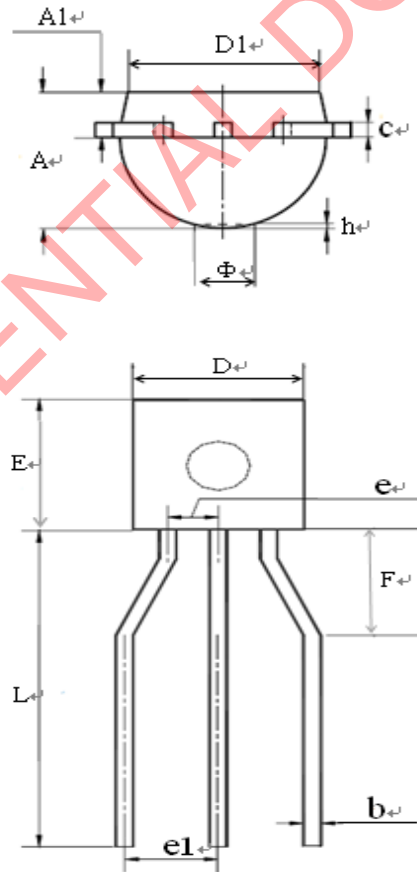
**TO-92(Ammo)**

Symbol	Dimensions in Millimeters		Dimensions in Inches	
	Min	Max	Min	Max
A	3.300	3.700	0.130	0.146
A1	1.100	1.400	0.043	0.055
b	0.380	0.550	0.015	0.022
c	0.360	0.510	0.014	0.020
D	4.400	4.700	0.173	0.185
D1	3.430	-	0.135	-
E	4.300	4.700	0.169	0.185
e	1.270TYP		0.050 TYP	
e1	2.540 TYP		0.100 TYP	
F	2.500	4.000	0.071	0.098
L	13.000	14.000	0.512	0.551
Φ	-	1.600	-	0.063
h	0.000	0.380	0.000	0.015



Shaoxing Devechip Microelectronics Co., Ltd.

<http://www.sdc-semi.com/>

#### IMPORTANT NOTICE

Information in this document is provided solely in connection with Shaoxing Devechip Microelectronics Co., Ltd. (abbr. SDC) products. SDC reserves the right to make changes, corrections, modifications or improvements, to this document, and the products and services described herein at anytime, without notice. SDC does not assume any responsibility for use of any its products for any particular purpose, nor does SDC assume any liability arising out of the application or use of any its products or circuits. SDC does not convey any license under its patent rights or other rights nor the rights of others.

© 2014 Devechip Microelectronics - All rights reserved

---

Contact us:

**Headquarters of Shaoxing**

Address: Tian Mu Road, No13,

Shaoxing city, Zhejiang province, China

Zip code: 312000

Tel: (86) 0575-8861 6750

Fax: (86) 0575-8862 2882

**Shenzhen Branch**

Address: 22A, Shangbu building, Nan Yuan Road, No.68,

Futian District, Shenzhen city, Guangdong province, China

Zip code: 518031

Tel: (86) 0755-8366 1155

Fax: (86) 0755-8301 8528